

# Parts List, Charging Chart, Wiring Diagrams

PGH090 - PGH120  
3 Phase

**PACKAGE GAS ELECTRIC UNITS**



## TABLE OF CONTENTS

PARTS LIST-----	2-10
PARTS DRAWING-----	11-18
CHARGING CHARTS--	19-20
WIRING DIAGRAMS--	21-23



**PGH090 PARTS LIST**

KEY NO.	DESCRIPTION	FAST PARTS NO.	PGH090HDA00AAA	PGH090HEA00AAA	PGH090HFA00AAA	PGH090LDA00AAA	PGH090LEA00AAA	PGH090LFA00AAA
1	COMP ZR42K3-TF5-230	ZR42K3TF5230	2	2	2	*	*	*
1	COMP ZR42K3-TFD-230	ZR42K3TFD230	*	*	*	2	2	2
3	COIL ASY COND (7.5) AL	1171547	1	1	1	1	1	1
4	COIL ASY EVAP (7.5) AL	1171546	1	1	1	1	1	1
5	MTR BLW 3/230/460 2.9 1750	1175721	1	1	1	1	1	1
6	MTR CND 1/230 1/4 1100	1171335	2	2	2	*	*	*
6	MTR CND 1/460 1/4 1100	1171334	*	*	*	2	2	2
7	FAN C 22" 3B 1/2" 24 INT	1171220	2	2	2	2	2	2
8	CAP RN DUAL OV 370V 10+10	1175708	1	1	1	1	1	1
9	CAP RN OV 370V 4 MFD	1175500	1	1	1	1	1	1
10	CONTACTOR 2P 20A 24V	1171160	*	*	*	3	3	3
10	CONTACTOR 2P 30A 24V	1171554	2	2	2	*	*	*
11	CONTACTOR 2P 20A 24V	1171160	1	1	1	*	*	*
12	MODULE IGN UT 1068-11	1171166	1	1	1	*	*	*
12	MODULE IGN UT 1068-12	1171165	*	*	*	1	1	1
13	TRANS 208/230/460>24 75VA	1171496	1	1	1	1	1	1
14	WHEEL BLW 15X15 CW	1171050	1	1	1	1	1	1
15	WHEEL SI5.75x.938x5/16 CCW	1171049	1	1	1	1	1	1
16	FAN C 3.25" 12B 5/16" (INDUCER)	1171222	1	1	1	1	1	1
17	BOARD TERMINAL LO VOLT 8P	1171488	1	1	1	1	1	1
18	SWITCH LMT 195-80	1171325	1	1	1	1	1	1
19	REGULATOR EXHAUST	1175855	1	*	*	1	*	*
19	REGULATOR EXHAUST	1171432	*	1	*	*	1	*
19	REGULATOR EXHAUST	1176302	*	*	1	*	*	1
20	SWITCH TMP	1171324	1	1	1	1	1	1
21	SENSOR FLAME	1171449	1	1	1	1	1	1
22	IGNITOR	1171306	1	1	1	1	1	1
23	MANAFOLD ASY (HIGH HEAT)	1171328	*	*	1	*	*	1
23	MANAFOLD ASY (LOW HEAT)	1176297	1	*	*	1	*	*
23	MANAFOLD ASY (MED HEAT)	1176303	*	1	*	*	1	*
24	BURNER ASY	1171095	2	2	2	2	2	2
25	BURNER ASY	1171087	1	2	3	1	2	3
26	RING INSERT	1171439	3	4	5	3	4	5
27	VALVE N HSI 2STG WR 36G54508	1175853	1	*	*	1	*	*
27	VALVE N HSI 2STG WR 36H54470	1175187	*	*	1	*	*	1
27	VALVE N HSI 2STG WR 36H54471	1176305	*	1	*	*	1	*
28	ORIFICE MAIN 31	1171462	3	4	5	3	4	5
29	INDUCER MOTOR ASY 230V	1171314	1	1	1	*	*	*
29	INDUCER MOTOR ASY 460V	1171315	*	*	*	1	1	1
30	SENSOR (HALL EFFECT)	1171450	1	1	1	1	1	1
31	MTR VNT 1/230 1/16HP	1171348	1	1	1	*	*	*
31	MTR VNT 1/460 1/16HP	1171347	*	*	*	1	1	1
33	HEAT EX (HIGH HEAT)	1171287	*	*	1	*	*	1
33	HEAT EX (LOW HEAT)	1176298	1	*	*	1	*	*
33	HEAT EX (MED HEAT)	1176301	*	1	*	*	1	*
36	KIT BRNR WIRING	1171894	1	1	1	1	1	1
37	PLUG WIRING ASY (PL6)	1173199	1	1	1	1	1	1
38	DRIER FILTER	1171555	2	2	2	2	2	2
39	FREEZE STAT O30 C45	1171252	1	1	1	1	1	1

**PGH090 PARTS LIST (continued)**

KEY NO.	DESCRIPTION	FAST PARTS NO.	PGH090HDA00AAA	PGH090HEA00AAA	PGH090HFA00AAA	PGH090LDA00AAA	PGH090LEA00AAA	PGH090LFA00AAA
41	RELAY 24V DPST 9100-211Q28	1171809	1	1	1	1	1	1
42	BEARING	1175709	2	2	2	2	2	2
43	KEY	1171322	1	1	1	1	1	1
44	PULLEY (BLW)	1175315	1	1	1	1	1	1
45	PULLEY (MTR)	1175720	1	1	1	1	1	1
46	BELT	1176299	1	1	1	1	1	1
47	SHAFT	1175730	1	1	1	1	1	1
48	SWITCH PRESSURE (LOW)	1175308	2	2	2	2	2	2
49	CIRCUIT BREAKER	1171114	1	1	1	1	1	1
50	SWITCH PRESSURE (HIGH)	1171805	2	2	2	2	2	2
52	RELAY (CLO)	1171434	2	2	2	2	2	2
A	FILTER 16X25X2	1175312	4	4	4	4	4	4
AA	PANEL FILTER DOOR (UPPER)	1171386	1	1	1	1	1	1
AB	PANEL ASY (INDOOR END)	1171375	1	1	1	1	1	1
AC	PANEL ASY (INDOOR FAN ACCESS)	1171004	1	1	1	1	1	1
AD	PANEL OUTDOOR (POWER)	1171003	1	1	1	1	1	1
AE	PLATE (FAN MTR SIDE)	1171395	1	1	1	1	1	1
AF	PLATE (FAN SIDE)	1171396	1	1	1	1	1	1
AG	PLATE WIRING	1171373	1	1	1	1	1	1
AH	POST CENTER (FILTER SIDE)	1171406	1	1	1	1	1	1
AJ	POST CENTER (FAN ACCESS)	1171409	1	1	1	1	1	1
AK	POST CORNER (COIL)	1171177	1	1	1	1	1	1
AL	POST CORNER (CONTRL BOX SIDE)	1171173	1	1	1	1	1	1
AM	POST CORNER (INDOOR END)	1171175	2	2	2	2	2	2
AN	RACEWAY (OFM)	1171428	2	2	2	2	2	2
AP	RAIL BASE (FILTER ACCESS)	1171033	1	1	1	1	1	1
AQ	RAIL BASE (FAN ACCESS)	1171031	1	1	1	1	1	1
AR	RAIL BASE (ICP)	1175313	1	1	1	1	1	1
AS	RETAINER (FLAME)	1176300	1	*	*	1	*	*
AS	RETAINER (FLAME)	1176304	*	1	*	*	1	*
AS	RETAINER (FLAME)	1171246	*	*	1	*	*	1
AV	PLATE ASY IFM MTR	1175664	1	1	1	1	1	1
AW	SCROLL (FAN)	1175260	1	1	1	1	1	1
AX	SUPPORT ASY (INDUCED DRAFT)	1171473	1	1	1	1	1	1
AY	SUPPORT (BURNER)	1171094	1	1	1	1	1	1
AZ	SUPPORT (HEAT)	1171469	1	1	1	1	1	1
B	BOOT CAPACITOR	1171842	1	1	1	1	1	1
BA	BOLT COMP MTG	1171056	8	8	8	8	8	8
BB	DRAIN LINE SEAL (ROUND)	1171447	1	1	1	1	1	1
BC	BRACKET MTR SUPPORT	1175711	1	1	1	1	1	1
BD	BRACKET ASY BRG	1175712	2	2	2	2	2	2
BE	BLOWER ASY	1172637	1	1	1	1	1	1
C	BRACKET BASE (CORNER)	1171071	2	2	2	2	2	2
D	BRACKET COIL (HEADER END)	1171070	1	1	1	1	1	1
E	CHANNEL (DUCT)	1171112	1	1	1	1	1	1
F	CLAMP CAPACITOR OVL	1171552	1	1	1	1	1	1
G	COVER ASY (TOP)	1171365	1	1	1	1	1	1
H	COVER (CONTROL BOX)	1171169	1	1	1	1	1	1
J	COVER ASY (RETURN AIR)	1171182	1	1	1	1	1	1

**PGH090 PARTS LIST (continued)**

KEY NO.	DESCRIPTION	FAST PARTS NO.	PGH090HDA00AAA	PGH090HEA00AAA	PGH090HFA00AAA	PGH090LDA00AAA	PGH090LEA00AAA	PGH090LFA00AAA
K	COVER ASY (SUPPLY AIR)	1171181	1	1	1	1	1	1
L	GASKET (REGULATOR)	1171265	1	1	1	1	1	1
M	GRILLE (OUTLET)	1171267	1	1	1	1	1	1
N	GROMMET COMP 1.25"DIA	1171269	8	8	8	8	8	8
P	GUARD (BASERAIL)	1171206	1	1	1	1	1	1
Q	GUARD (LIMIT SWITCH)	1171271	1	1	1	1	1	1
R	STRAP FORMED	1171537	1	1	1	1	1	1
S	KIT (HOOD EXHAUST)	1173617	1	1	1	1	1	1
T	HOUSING (FAN)	1171301	1	1	1	1	1	1
V	INSULATION	1171317	1	1	1	1	1	1
W	PAN CONDENSATE	1171359	1	1	1	1	1	1
X	PANEL ACCESS (BURNER CNTRLS)	1171139	1	1	1	1	1	1
Z	PANEL FILTER (LOWER)	1171382	1	1	1	1	1	1
PARTS NOT SHOWN								
)	( HARNES ASY (COMMON)	1171525	1	1	1	1	1	1
)	( HARNES ASY (COMP)	1175150	1	1	1	1	1	1
)	( HARNES ASY (IFM)	1175707	1	1	1	1	1	1
)	( HARNES ASY (IGN CONTROL)	1175166	1	1	1	1	1	1
)	( PLUG ASY (ECON)	1171405	1	1	1	1	1	1
)	( PLUG ASY (YAC)	1171523	1	1	1	1	1	1

**PGH102 PARTS LIST**

KEY NO.	DESCRIPTION	FAST PARTS NO.	PGH102HDA00AAA	PGH102HEA00AAA	PGH102HFA00AAA	PGH102LDA00AAA	PGH102LEA00AAA	PGH102LFA00AAA
1	COMP SRH482HC	1175403	*	*	*	2	2	2
1	COMP SRY482HC	1175409	2	2	2	*	*	*
3	COIL ASY COND (10) AL	1171541	1	1	1	1	1	1
4	COIL ASY EVAP (10) AL	1176356	1	1	1	1	1	1
5	MTR BLW 3/230/460 2.9 1750	1175721	1	1	1	1	1	1
6	MTR CND 1/230 1/4 1100	1171335	2	2	2	*	*	*
6	MTR CND 1/460 1/4 1100	1171334	*	*	*	2	2	2
7	FAN C 22" 3B 1/2" 24 INT	1171220	2	2	2	2	2	2
8	CAP RN DUAL OV 370V 10+10	1175708	1	1	1	1	1	1
9	CAP RN OV 370V 4 MFD	1175500	1	1	1	1	1	1
10	CONTACTOR 2P 20A 24V	1171160	*	*	*	3	3	3
10	CONTACTOR 2P 30A 24V	1171554	2	2	2	*	*	*
11	CONTACTOR 2P 20A 24V	1171160	1	1	1	*	*	*
12	MODULE IGN UT 1068-11	1171166	1	1	1	*	*	*
12	MODULE IGN UT 1068-12	1171165	*	*	*	1	1	1
13	TRANS 208/230/460>24 75VA	1171496	1	1	1	*	*	*
13	TRANS 208/230/460>24 75VA	1171496	*	*	*	1	1	1
14	WHEEL BLW 15X15 CW	1171050	1	1	1	1	1	1
15	WHEEL SI5.75x.938x5/16 CCW	1171049	1	1	1	1	1	1
16	FAN C 3.25" 12B 5/16" (INDUCER)	1171222	1	1	1	1	1	1
17	BOARD TERMINAL LO VOLT 8P	1171488	1	1	1	1	1	1
18	SWITCH LMT 195-80	1171325	1	1	1	1	1	1
19	REGULATOR EXHAUST	1175855	1	*	*	1	*	*
19	REGULATOR EXHAUST	1176302	*	1	*	*	1	*
19	REGULATOR EXHAUST	1171432	*	*	1	*	*	1
20	SWITCH TMP	1171324	1	1	1	1	1	1
21	SENSOR FLAME	1171449	1	1	1	1	1	1
22	IGNITOR	1171306	1	1	1	1	1	1
23	MANAFOLD ASY	1176303	*	1	*	*	1	*
23	MANAFOLD ASY	1171328	*	*	1	*	*	1
23	MANAFOLD ASY (LOW HEAT)	1176297	1	*	*	1	*	*
24	BURNER ASY	1171095	2	2	2	2	2	2
25	BURNER ASY	1171087	1	2	3	1	2	3
26	RING INSERT	1171439	3	4	5	3	4	5
27	VALVE N HSI 2STG WR 36G54508	1175853	1	*	*	1	*	*
27	VALVE N HSI 2STG WR 36H54470	1175187	*	*	1	*	*	1
27	VALVE N HSI 2STG WR 36H54471	1176305	*	1	*	*	1	*
28	ORIFICE MAIN 30	1171461	*	*	5	*	*	5
28	ORIFICE MAIN 31	1171462	3	4	*	3	4	*
29	INDUCER MOTOR ASY 230V	1171314	1	1	1	*	*	*
29	INDUCER MOTOR ASY 460V	1171315	*	*	*	1	1	1
30	SENSOR (HALL EFFECT)	1171450	1	1	1	1	1	1
31	MTR VNT 1/230 1/16HP	1171348	1	1	1	*	*	*
31	MTR VNT 1/460 1/16HP	1171347	*	*	*	1	1	1
33	HEAT EX (HIGH HEAT)	1171287	*	*	1	*	*	1
33	HEAT EX (LOW HEAT)	1176298	1	*	*	1	*	*
33	HEAT EX (MED HEAT)	1176301	*	1	*	*	1	*
36	KIT BRNR WIRING	1171894	1	1	1	1	1	1
37	PLUG WIRING ASY (PL6)	1173199	1	1	1	1	1	1

**PGH102 PARTS LIST (continued)**

KEY NO.	DESCRIPTION	FAST PARTS NO.	PGH102HDA00AAA	PGH102HEA00AAA	PGH102HFA00AAA	PGH102LDA00AAA	PGH102LEA00AAA	PGH102LFA00AAA
38	DRIER FILTER	1171555	2	2	2	2	2	2
39	FREEZE STAT O30 C45	1171252	1	1	1	1	1	1
41	RELAY 24V DPST 9100-211Q28	1171809	1	1	1	1	1	1
42	BEARING	1175709	2	2	2	2	2	2
43	KEY	1171322	1	1	1	1	1	1
44	PULLEY (BLW)	1175315	1	1	1	1	1	1
45	PULLEY (MTR)	1175720	1	1	1	1	1	1
46	BELT	BLTA48	1	1	1	1	1	1
47	SHAFT	1175730	1	1	1	1	1	1
48	SWITCH PRESSURE (LOW)	1175308	2	2	2	2	2	2
49	CIRCUIT BREAKER	1171114	1	1	1	1	1	1
50	SWITCH PRESSURE (HIGH)	1171805	2	2	2	2	2	2
52	RELAY (CLO)	1171434	2	2	2	2	2	2
A	FILTER 20X20X2	1176306	4	4	4	4	4	4
AA	PANEL FILTER DOOR (UPPER)	1171385	1	1	1	1	1	1
AB	PANEL ASY (INDOOR END)	1171308	1	1	1	1	1	1
AC	PANEL ASY (INDOOR FAN ACCESS)	1171364	1	1	1	1	1	1
AD	PANEL OUTDOOR (POWER)	1171368	1	1	1	1	1	1
AE	PLATE (FAN MTR SIDE)	1171227	1	1	1	1	1	1
AF	PLATE (FAN SIDE)	1171218	1	1	1	1	1	1
AG	PLATE WIRING	1171373	1	1	1	1	1	1
AH	POST CENTER (FILTER SIDE)	1171109	1	1	1	1	1	1
AJ	POST CENTER (FAN ACCESS)	1171410	1	1	1	1	1	1
AK	POST CORNER (COIL)	1171174	1	1	1	1	1	1
AL	POST CORNER (CONTRL BOX SIDE)	1171172	1	1	1	1	1	1
AM	POST CORNER (INDOOR END)	1171309	2	2	2	2	2	2
AN	RACEWAY (OFM)	1171428	1	1	1	1	1	1
AP	RAIL BASE (FILTER ACCESS)	1171033	1	1	1	1	1	1
AQ	RAIL BASE (FAN ACCESS)	1171031	1	1	1	1	1	1
AR	RAIL BASE	1171032	1	1	1	1	1	1
AS	RETAINER (FLAME)	1176300	1	*	*	1	*	*
AS	RETAINER (FLAME)	1176304	*	1	*	*	1	*
AS	RETAINER (FLAME)	1171247	*	*	1	*	*	1
AV	PLATE MTR MTG	1175891	1	1	1	1	1	1
AW	SCROLL (FAN)	1171223	1	1	1	1	1	1
AX	SUPPORT ASY (INDUCED DRAFT)	1171473	1	1	1	1	1	1
AY	SUPPORT (BURNER)	1171094	1	1	1	1	1	1
AZ	SUPPORT (HEAT)	1171469	1	1	1	1	1	1
B	BOOT CAPACITOR	1171842	1	1	1	1	1	1
BA	BOLT COMP MTG	1171056	8	8	8	8	8	8
BB	DRAIN LINE SEAL (ROUND)	1171447	1	1	1	1	1	1
BC	BRACKET MTR ADJ	1175913	1	1	1	1	1	1
BD	BRACKET ASY BRG	1175712	2	2	2	2	2	2
BE	BLOWER ASY	1175411	1	1	1	1	1	1
BF	BRACKET	1175713	1	1	1	1	1	1
BG	BRACKET MTR MTG	1175911	2	2	2	2	2	2
BH	BRACKET MTR	1175912	2	2	2	2	2	2
BJ	BOLT MTR ADJ 5/16-18 X 12"	1175914	2	2	2	2	2	2
C	BRACKET BASE (CORNER)	1171071	2	2	2	2	2	2

**PGH102 PARTS LIST (continued)**

KEY NO.	DESCRIPTION	FAST PARTS NO.	PGH102HDA00AAA	PGH102HEA00AAA	PGH102HFA00AAA	PGH102LDA00AAA	PGH102LEA00AAA	PGH102LFA00AAA
D	BRACKET COIL (HEADER END)	1171070	1	1	1	1	1	1
E	CHANNEL (DUCT)	1171112	1	1	1	1	1	1
F	CLAMP CAPACITOR OVL	1171552	1	1	1	1	1	1
G	COVER ASY (TOP)	1171365	1	1	1	1	1	1
H	COVER (CONTROL BOX)	1171169	1	1	1	1	1	1
J	COVER ASY (RETURN AIR)	1171182	1	1	1	1	1	1
K	COVER ASY (SUPPLY AIR)	1171180	1	1	1	1	1	1
L	GASKET (REGULATOR)	1171265	1	1	1	1	1	1
M	GRILLE (OUTLET)	1171267	1	1	1	1	1	1
N	GROMMET COMP 1.25"DIA	1171269	8	8	8	8	8	8
P	GUARD (BASERAIL)	1171206	1	1	1	1	1	1
Q	GUARD (LIMIT SWITCH)	1171271	1	1	1	1	1	1
R	STRAP FORMED	1171537	1	1	1	1	1	1
S	KIT (HOOD EXHAUST)	1173617	1	1	1	1	1	1
T	HOUSING (FAN)	1171301	1	1	1	1	1	1
V	INSULATION	1171317	1	1	1	1	1	1
W	PAN CONDENSATE	1171359	1	1	1	1	1	1
X	PANEL ACCESS (BURNER CNTRLS)	1171383	1	1	1	1	1	1
Z	PANEL FILTER (LOWER)	1171382	1	1	1	1	1	1
PARTS NOT SHOWN								
)	HARNESS ASY (COMMON)	1171525	1	1	1	1	1	1
)	HARNESS ASY (COMP)	1175150	1	1	1	1	1	1
)	HARNESS ASY (IFM)	1175707	1	1	1	1	1	1
)	HARNESS ASY (IGN CONTROL)	1175166	1	1	1	1	1	1
)	PLUG ASY (ECON)	1171405	1	1	1	1	1	1
)	PLUG ASY (YAC)	1171523	1	1	1	1	1	1

**PGH120 PARTS LIST**

KEY NO.	DESCRIPTION	FAST PARTS NO.	PGH120HDA00AAA	PGH120HEA00AAA	PGH120HFA00AAA	PGH120LDA00AAA	PGH120LEA00AAA	PGH120LFA00AAA
1	COMP SRH552HE	1175404	*	*	*	2	2	2
1	COMP SRY552HE	1175410	2	2	2	*	*	*
3	COIL ASY COND (10) AL	1171541	1	1	1	1	1	1
4	COIL ASY EVAP (10) AL	1176356	1	1	1	1	1	1
5	MTR BLW 3/230/460 2.4 1750	1175478	1	1	1	1	1	1
6	MTR CND 1/230 1/4 1100	1171335	2	2	2	*	*	*
6	MTR CND 1/460 1/4 1100	1171334	*	*	*	2	2	2
7	FAN C 22" 3B 1/2" 24 INT	1171220	2	2	2	2	2	2
8	CAP RN DUAL OV 370V 10+10	1175708	1	1	1	1	1	1
9	CAP RN OV 370V 4 MFD	1175500	1	1	1	1	1	1
10	CONTACTOR 2P 20A 24V	1171160	*	*	*	3	3	3
10	CONTACTOR 2P 30A 24V	1171554	2	2	2	*	*	*
11	CONTACTOR 2P 20A 24V	1171160	1	1	1	*	*	*
12	MODULE IGN UT 1068-11	1171166	1	1	1	*	*	*
12	MODULE IGN UT 1068-12	1171165	*	*	*	1	1	1
13	TRANS 208/230/460>24 75VA	1171496	1	1	1	1	1	1
14	WHEEL BLW 15X15 CW	1171050	1	1	1	1	1	1
15	WHEEL SI5.75x.938x5/16 CCW	1171049	1	1	1	1	1	1
16	FAN C 3.25" 12B 5/16" (INDUCER)	1171222	1	1	1	1	1	1
17	BOARD TERMINAL LO VOLT 8P	1171488	1	1	1	1	1	1
18	SWITCH LMT 195-80	1171325	1	1	1	1	1	1
19	REGULATOR EXHAUST	1176302	1	*	*	1	*	*
19	REGULATOR EXHAUST	1171432	*	1	1	*	1	1
20	SWITCH TMP	1171324	1	1	1	1	1	1
21	SENSOR FLAME	1171449	1	1	1	1	1	1
22	IGNITOR	1171306	1	1	1	1	1	1
23	MANAFOLD ASY	1176303	1	*	*	1	*	*
23	MANAFOLD ASY	1171328	*	1	1	*	1	1
24	BURNER ASY	1171095	2	2	2	2	2	2
25	BURNER ASY	1171087	2	3	3	2	3	3
26	RING INSERT	1171439	4	5	5	4	5	5
27	VALVE N HSI 2STG WR 36H54470	1175187	*	1	1	*	1	1
27	VALVE N HSI 2STG WR 36H54471	1176305	1	*	*	1	*	*
28	ORIFICE MAIN 30	1171461	*	*	5	*	*	5
28	ORIFICE MAIN 31	1171462	4	5	*	4	5	*
29	INDUCER MOTOR ASY 230V	1171314	1	1	1	*	*	*
29	INDUCER MOTOR ASY 460V	1171315	*	*	*	1	1	1
30	SENSOR (HALL EFFECT)	1171450	1	1	1	1	1	1
31	MTR VNT 1/230 1/16HP	1171348	1	1	1	*	*	*
31	MTR VNT 1/460 1/16HP	1171347	*	*	*	1	1	1
33	HEAT EX (HIGH HEAT)	1171288	*	*	1	*	*	1
33	HEAT EX (LOW HEAT)	1176301	1	*	*	1	*	*
33	HEAT EX (MED HEAT)	1171287	*	1	*	*	1	*
36	KIT BRNR WIRING	1171894	1	1	1	1	1	1
37	PLUG WIRING ASY (PL6)	1173199	1	1	1	1	1	1
38	DRIER FILTER	1171555	2	2	2	2	2	2
39	FREEZE STAT O30 C45	1171252	1	1	1	1	1	1
41	RELAY 24V DPST 9100-211Q28	1171809	1	1	1	1	1	1
42	BEARING	1175709	2	2	2	2	2	2

**PGH120 PARTS LIST (continued)**

KEY NO.	DESCRIPTION	FAST PARTS NO.	PGH120HDA00AAA	PGH120HEA00AAA	PGH120HFA00AAA	PGH120LDA00AAA	PGH120LEA00AAA	PGH120LFA00AAA
43	KEY	1171322	1	1	1	1	1	1
44	PULLEY (BLW)	1175896	1	1	1	1	1	1
45	PULLEY (MTR)	1171562	1	1	1	1	1	1
46	BELT	1175710	1	1	1	1	1	1
47	SHAFT	1175730	1	1	1	1	1	1
48	SWITCH PRESSURE (LOW)	1175308	2	2	2	2	2	2
49	CIRCUIT BREAKER	1171114	1	1	1	1	1	1
50	SWITCH PRESSURE (HIGH)	1171805	2	2	2	2	2	2
52	RELAY (CLO)	1171434	2	2	2	2	2	2
A	FILTER 20X20X2	1176306	4	4	4	4	4	4
AA	PANEL FILTER DOOR (UPPER)	1171385	1	1	1	1	1	1
AB	PANEL ASY (INDOOR END)	1171308	1	1	1	1	1	1
AC	PANEL ASY (INDOOR FAN ACCESS)	1171364	1	1	1	1	1	1
AD	PANEL OUTDOOR (POWER)	1171368	1	1	1	1	1	1
AE	PLATE (FAN MTR SIDE)	1171227	1	1	1	1	1	1
AF	PLATE (FAN SIDE)	1171218	1	1	1	1	1	1
AG	PLATE WIRING	1171373	1	1	1	1	1	1
AH	POST CENTER (FILTER SIDE)	1171109	1	1	1	1	1	1
AJ	POST CENTER (FAN ACCESS)	1171410	1	1	1	1	1	1
AK	POST CORNER (COIL)	1171174	1	1	1	1	1	1
AL	POST CORNER (CONTRL BOX SIDE)	1171172	1	1	1	1	1	1
AM	POST CORNER (INDOOR END)	1171309	2	2	2	2	2	2
AN	RACEWAY (OFM)	1171428	1	1	1	*	*	*
AN	RACEWAY (OFM)	1171428	*	*	*	1	1	1
AP	RAIL BASE (FILTER ACCESS)	1171033	1	1	1	*	*	*
AP	RAIL BASE (FILTER ACCESS)	1171033	*	*	*	1	1	1
AQ	RAIL BASE (FAN ACCESS)	1171031	1	1	1	*	*	*
AQ	RAIL BASE (FAN ACCESS)	1171031	*	*	*	1	1	1
AR	RAIL BASE	1171032	1	1	1	*	*	*
AR	RAIL BASE	1171032	*	*	*	1	1	1
AS	RETAINER (FLAME)	1176304	1	*	*	*	*	*
AS	RETAINER (FLAME)	1171247	*	1	1	*	*	*
AS	RETAINER (FLAME)	1176304	*	*	*	1	*	*
AS	RETAINER (FLAME)	1171247	*	*	*	*	1	1
AV	PLATE MTR MTG	1175891	1	1	1	*	*	*
AV	PLATE MTR MTG	1175891	*	*	*	1	1	1
AW	SCROLL (FAN)	1171223	1	1	1	*	*	*
AW	SCROLL (FAN)	1171223	*	*	*	1	1	1
AX	SUPPORT ASY (INDUCED DRAFT)	1171473	1	1	1	*	*	*
AX	SUPPORT ASY (INDUCED DRAFT)	1171473	*	*	*	1	1	1
AY	SUPPORT (BURNER)	1171094	1	1	1	1	1	1
AZ	SUPPORT (HEAT)	1171469	1	1	1	1	1	1
B	BOOT CAPACITOR	1171842	1	1	1	1	1	1
BA	BOLT COMP MTG	1171056	8	8	8	8	8	8
BB	DRAIN LINE SEAL (ROUND)	1171447	1	1	1	1	1	1
BC	BRACKET MTR ADJ	1175913	1	1	1	1	1	1
BD	BRACKET ASY BRG	1175712	2	2	2	2	2	2
BE	BLOWER ASY	1175411	1	1	1	1	1	1
BF	BRACKET	1175713	1	1	1	1	1	1

**PGH120 PARTS LIST (continued)**

KEY NO.	DESCRIPTION	FAST PARTS NO.	PGH120HDA00AAA	PGH120HEA00AAA	PGH120HFA00AAA	PGH120LDA00AAA	PGH120LEA00AAA	PGH120LFA00AAA
BG	BRACKET MTR MTG	1175911	2	2	2	2	2	2
BH	BRACKET MTR	1175912	2	2	2	2	2	2
BJ	BOLT MTR ADJ 5/16-18 X 12"	1175914	2	2	2	2	2	2
C	BRACKET BASE (CORNER)	1171071	2	2	2	2	2	2
D	BRACKET COIL (HEADER END)	1171070	1	1	1	1	1	1
E	CHANNEL (DUCT)	1171112	1	1	1	1	1	1
F	CLAMP CAPACITOR OVL	1171552	1	1	1	1	1	1
G	COVER ASY (TOP)	1171365	1	1	1	1	1	1
H	COVER (CONTROL BOX)	1171169	1	1	1	1	1	1
J	COVER ASY (RETURN AIR)	1171182	1	1	1	1	1	1
K	COVER ASY (SUPPLY AIR)	1171180	1	1	1	1	1	1
L	GASKET (REGULATOR)	1171265	1	1	1	1	1	1
M	GRILLE (OUTLET)	1171267	1	1	1	1	1	1
N	GROMMET COMP 1.25"DIA	1171269	8	8	8	8	8	8
P	GUARD (BASERAIL)	1171206	1	1	1	1	1	1
Q	GUARD (LIMIT SWITCH)	1171271	1	1	1	1	1	1
R	STRAP FORMED	1171537	1	1	1	1	1	1
S	KIT (HOOD EXHAUST)	1173617	1	1	1	1	1	1
T	HOUSING (FAN)	1171301	1	1	1	1	1	1
V	INSULATION	1171317	1	1	1	1	1	1
W	PAN CONDENSATE	1171359	1	1	1	1	1	1
X	PANEL ACCESS (BURNER CNTRLS)	1171383	1	1	1	1	1	1
Z	PANEL FILTER (LOWER)	1171382	1	1	1	1	1	1
<b>PARTS NOT SHOWN</b>								
)	HARNESS ASY (COMMON)	1171525	1	1	1	1	1	1
)	HARNESS ASY (COMP)	1171520	1	1	1	1	1	1
)	HARNESS ASY (IFM)	1175707	1	1	1	1	1	1
)	HARNESS ASY (IGN CONTROL)	1175166	1	1	1	1	1	1
)	PLUG ASY (ECON)	1171405	1	1	1	1	1	1
)	PLUG ASY (YAC)	1171523	1	1	1	1	1	1

NOTE: This illustration is for reference only. Your unit may differ in appearance or may not include all components shown.

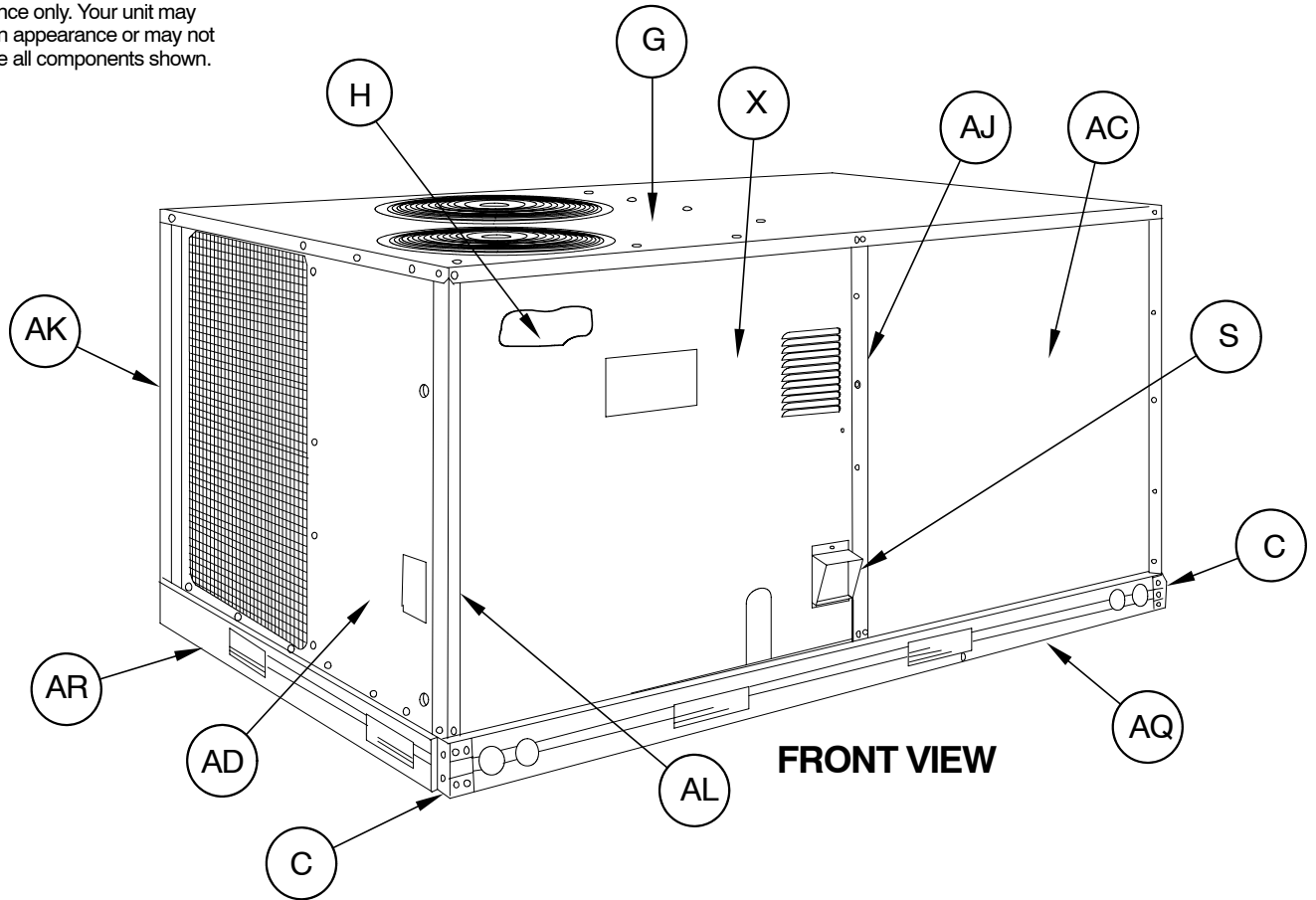

**FRONT VIEW**

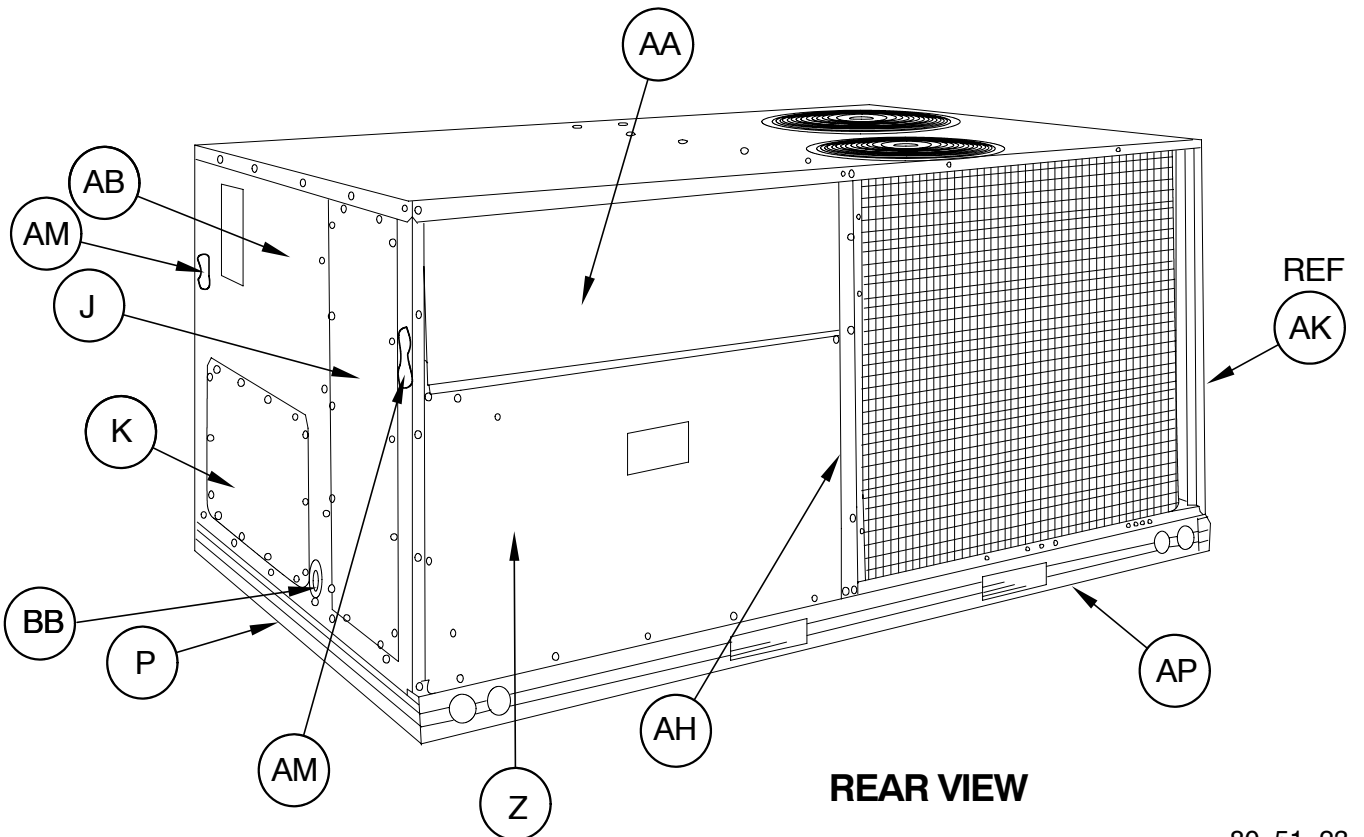

**REAR VIEW**



NOTE: This illustration is for reference only. Your unit may differ in appearance or may not include all components shown.

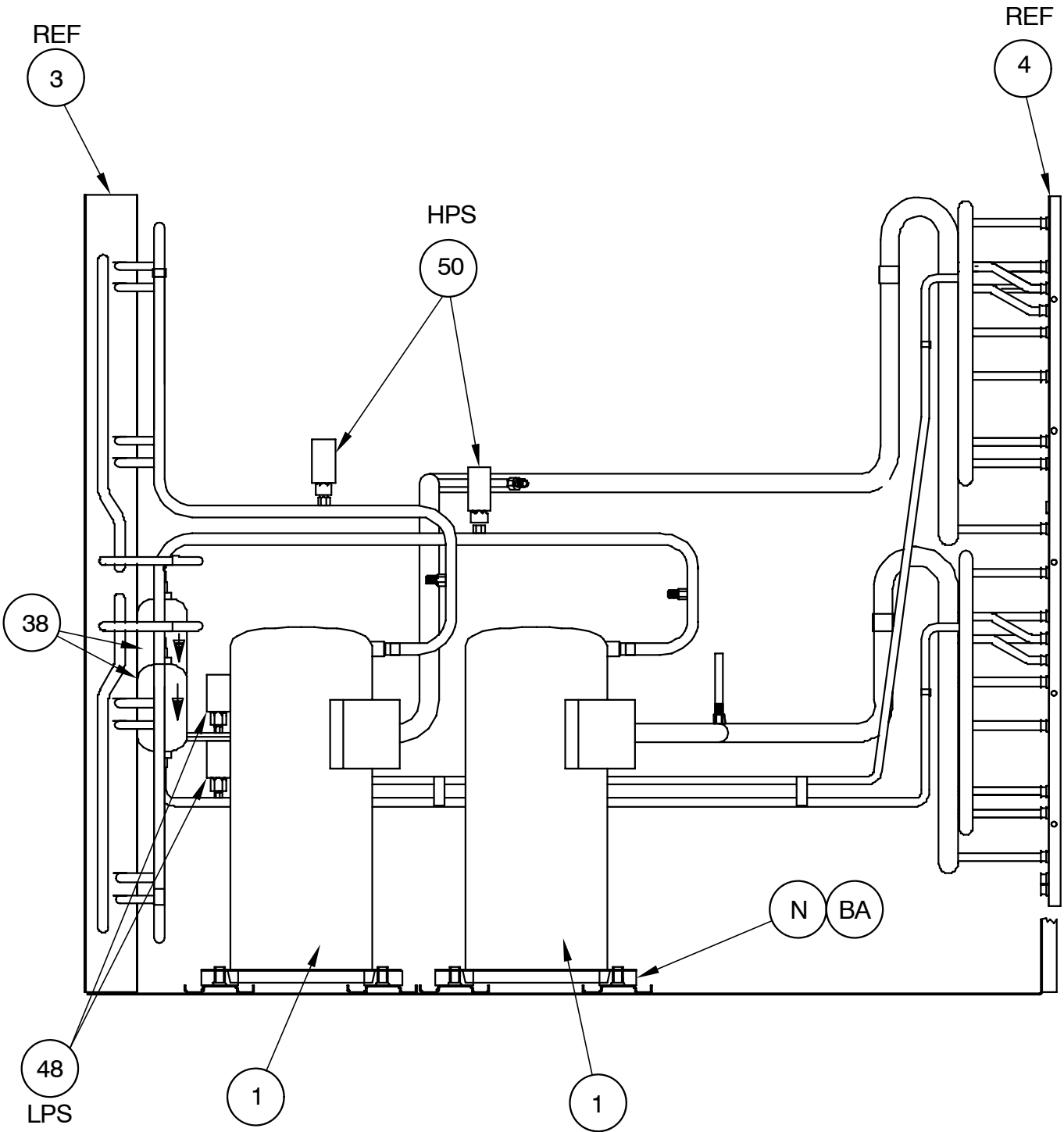

NOTE: This illustration is for reference only. Your unit may differ in appearance or may not include all components shown.

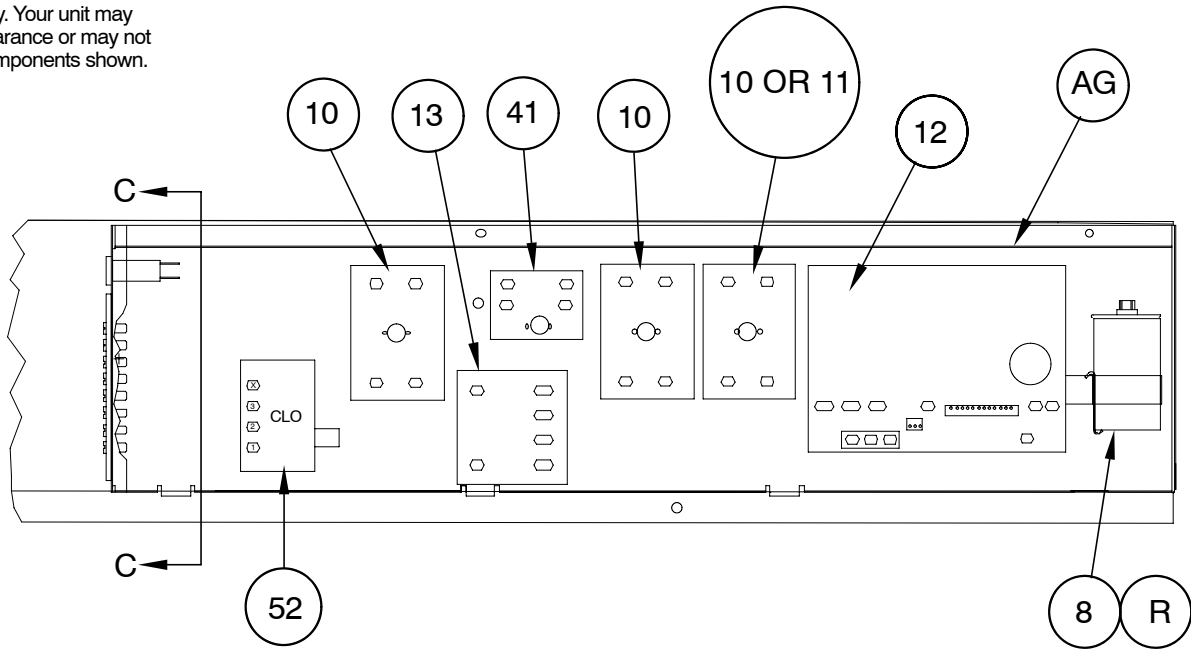

(CB)

**CONTROL BOX ASY.**

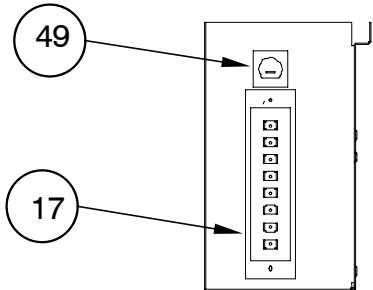

**VIEW C-C**

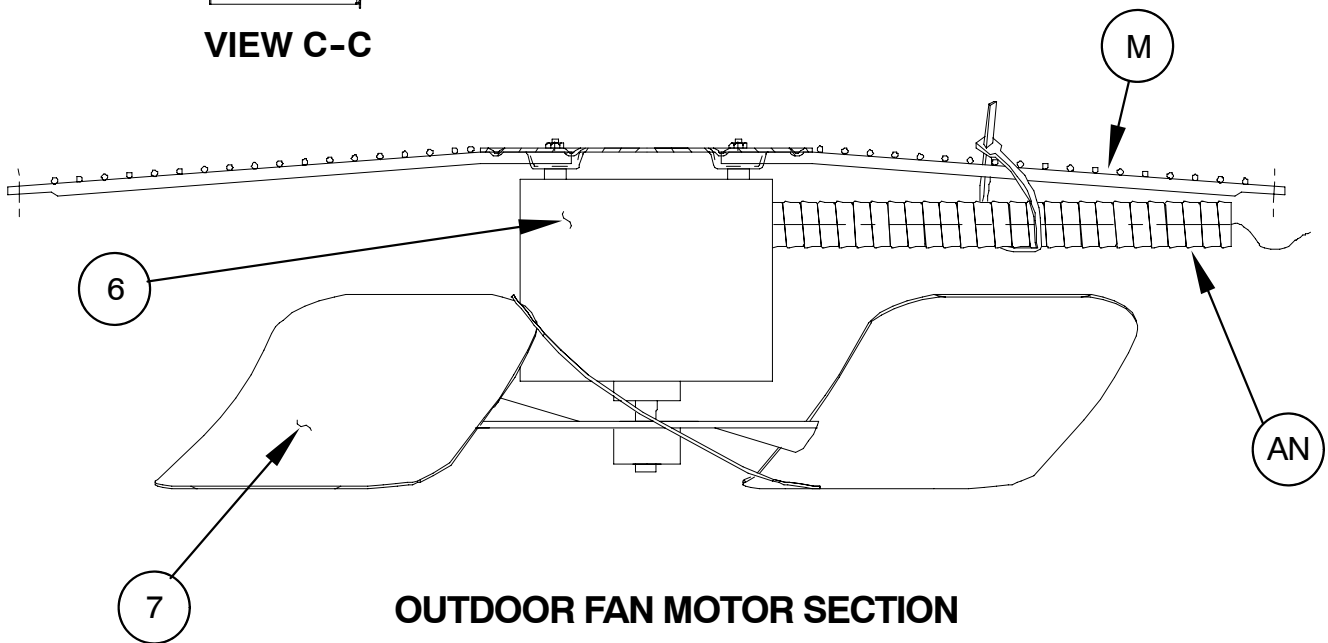

**OUTDOOR FAN MOTOR SECTION**

NOTE: This illustration is for reference only. Your unit may differ in appearance or may not include all components shown.

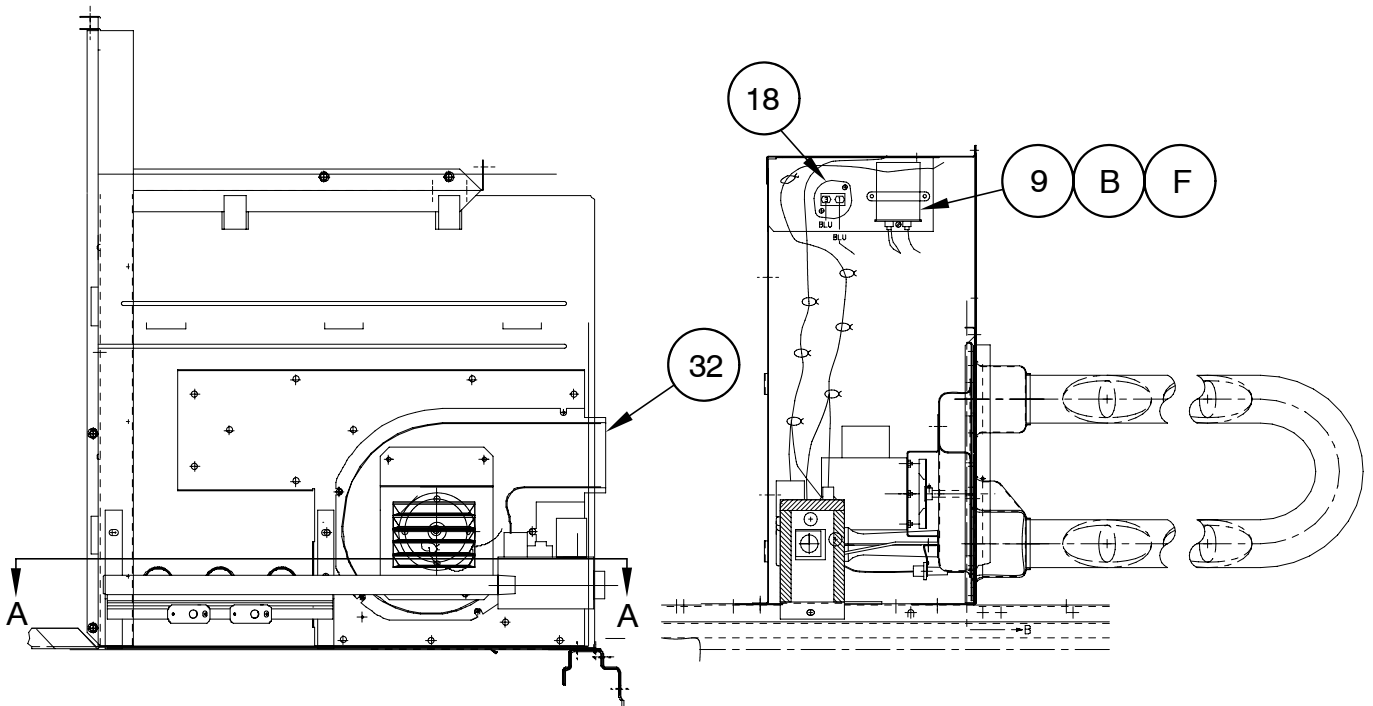
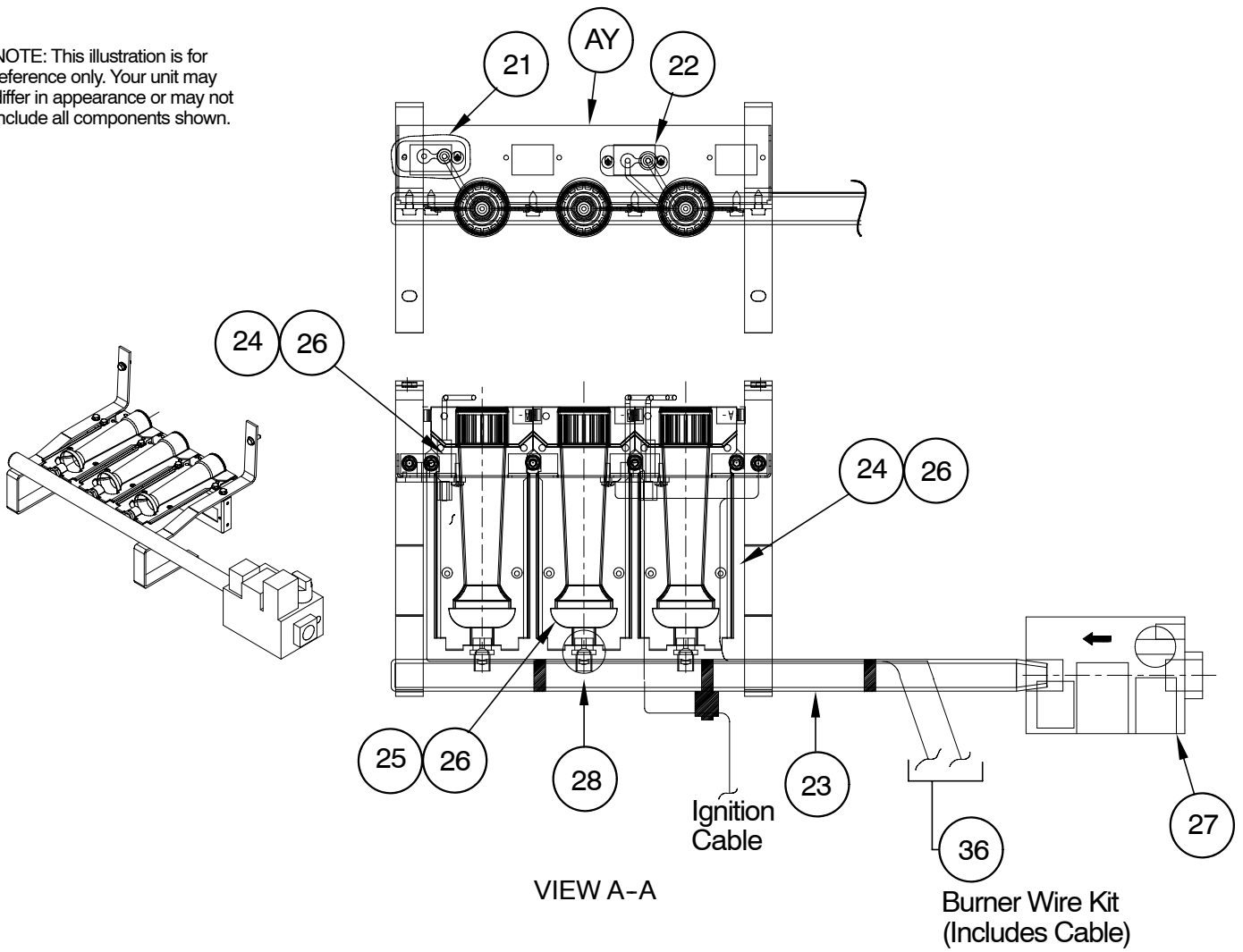

NOTE: This illustration is for reference only. Your unit may differ in appearance or may not include all components shown.

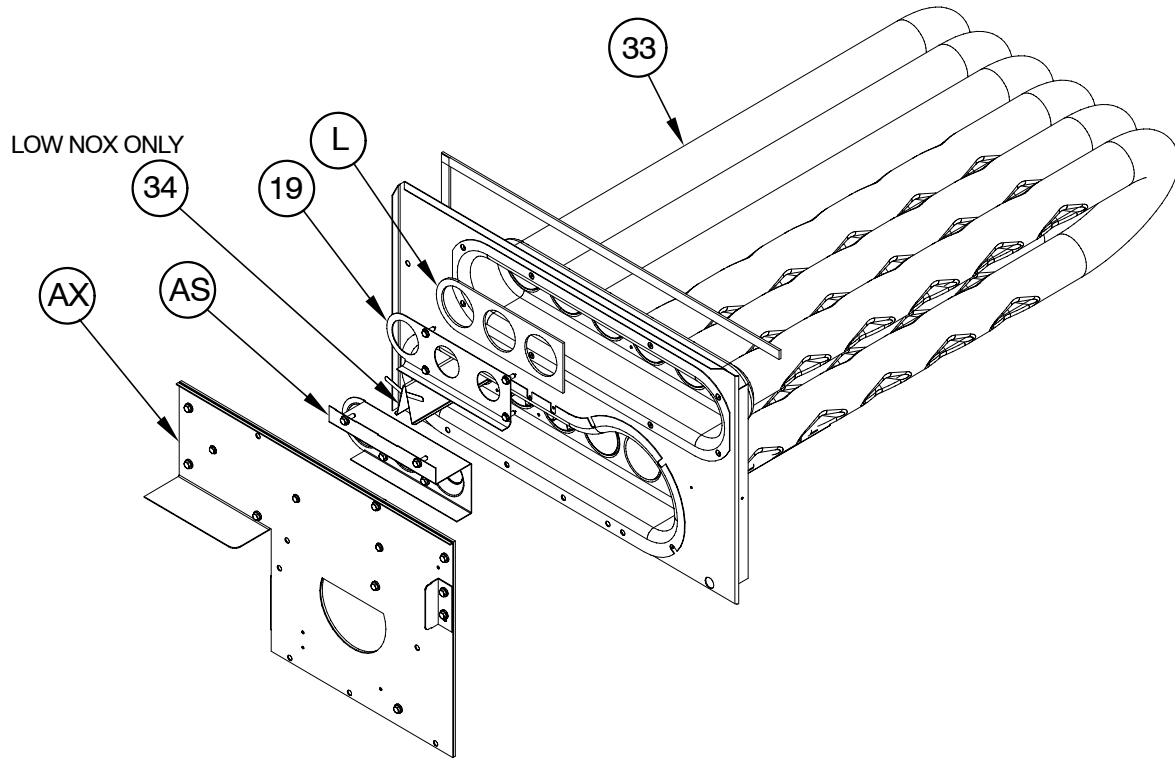

**HEAT EXCHANGER**

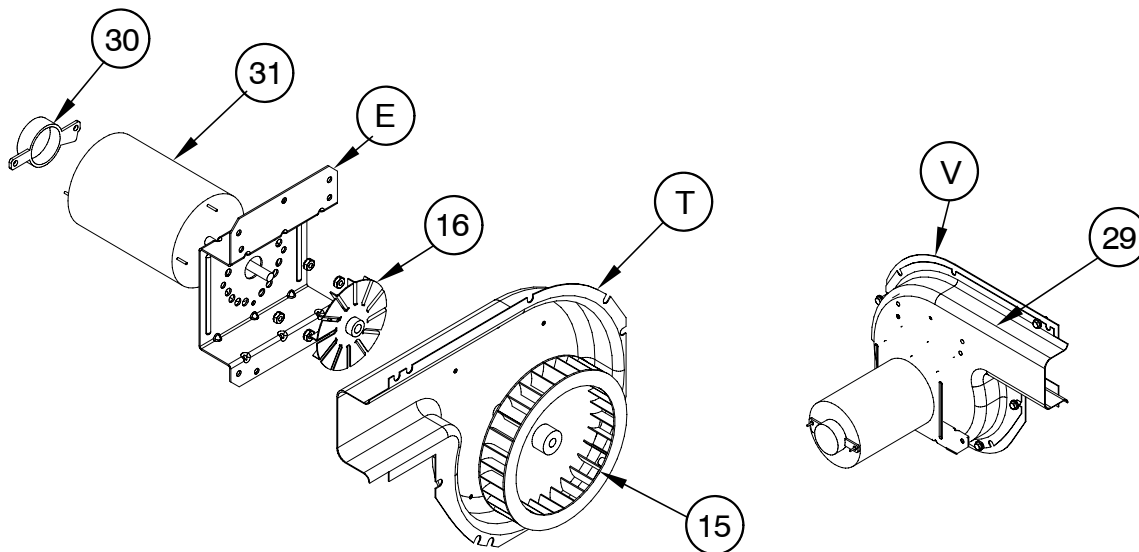

**INDUCED DRAFT MOTOR**



NOTE: This illustration is for reference only. Your unit may differ in appearance or may not include all components shown.

LOCKING COLLAR

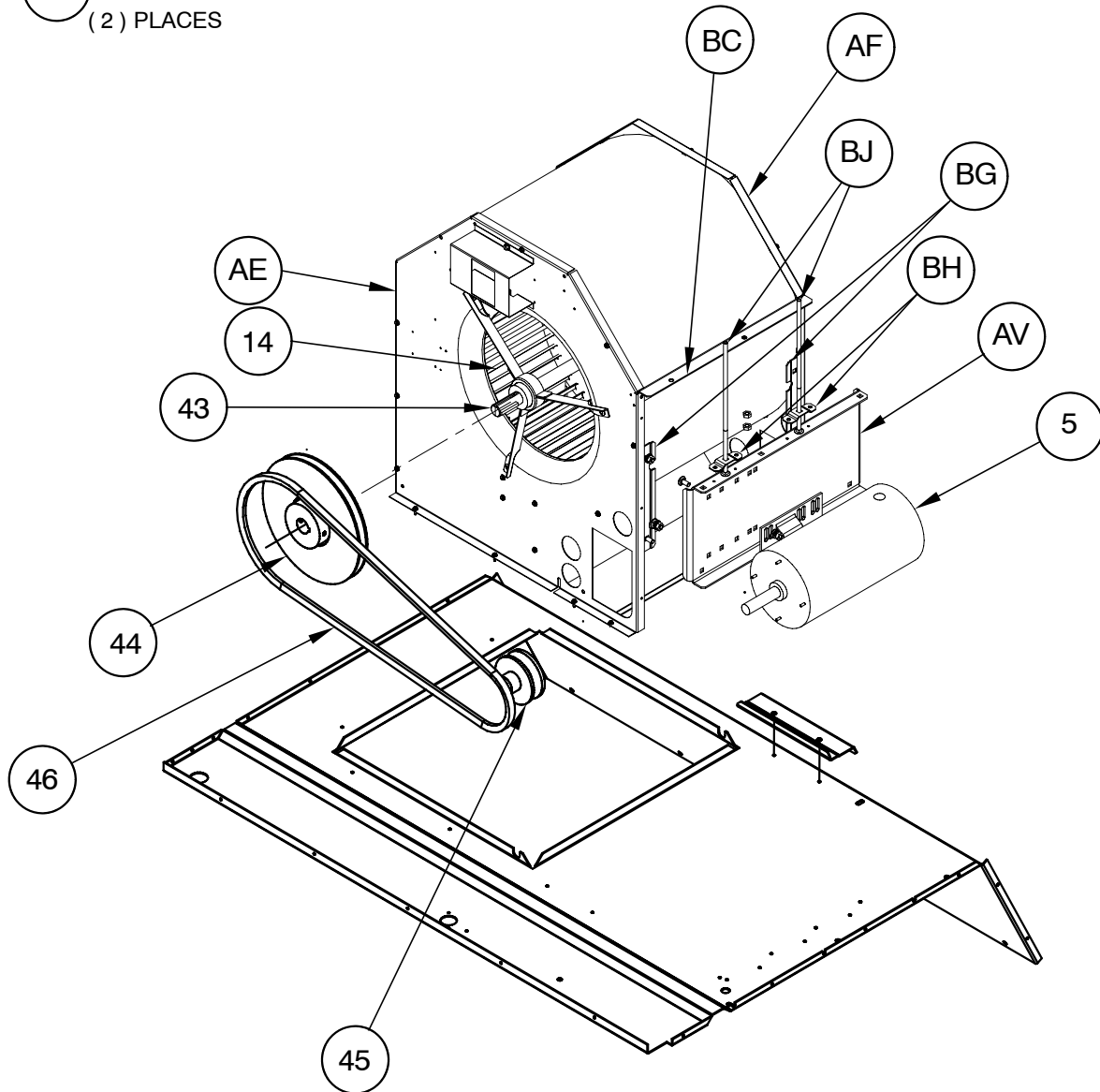
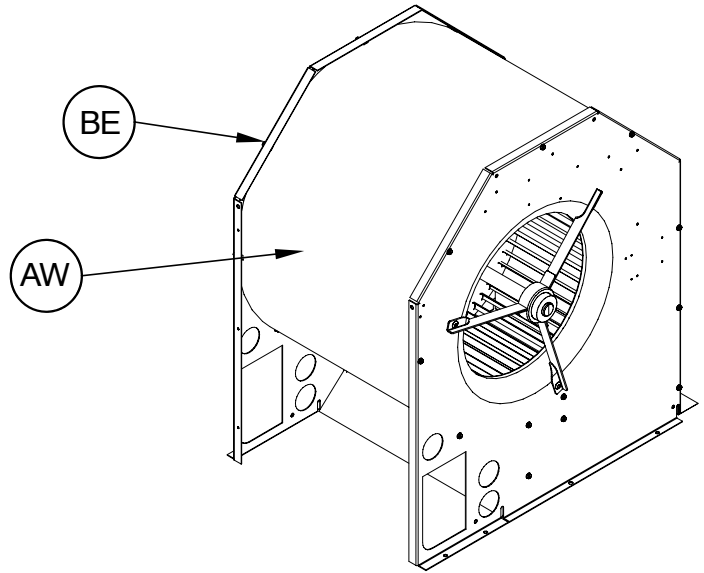
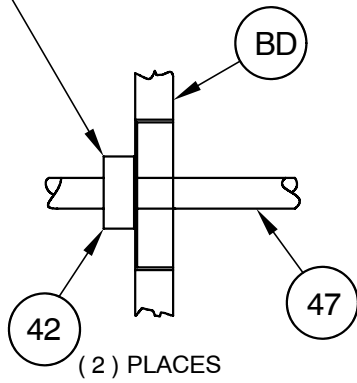

**INDOOR FAN SECTION**

7.5 TON 60HZ (CIRCUIT #1) CHARGING CHART

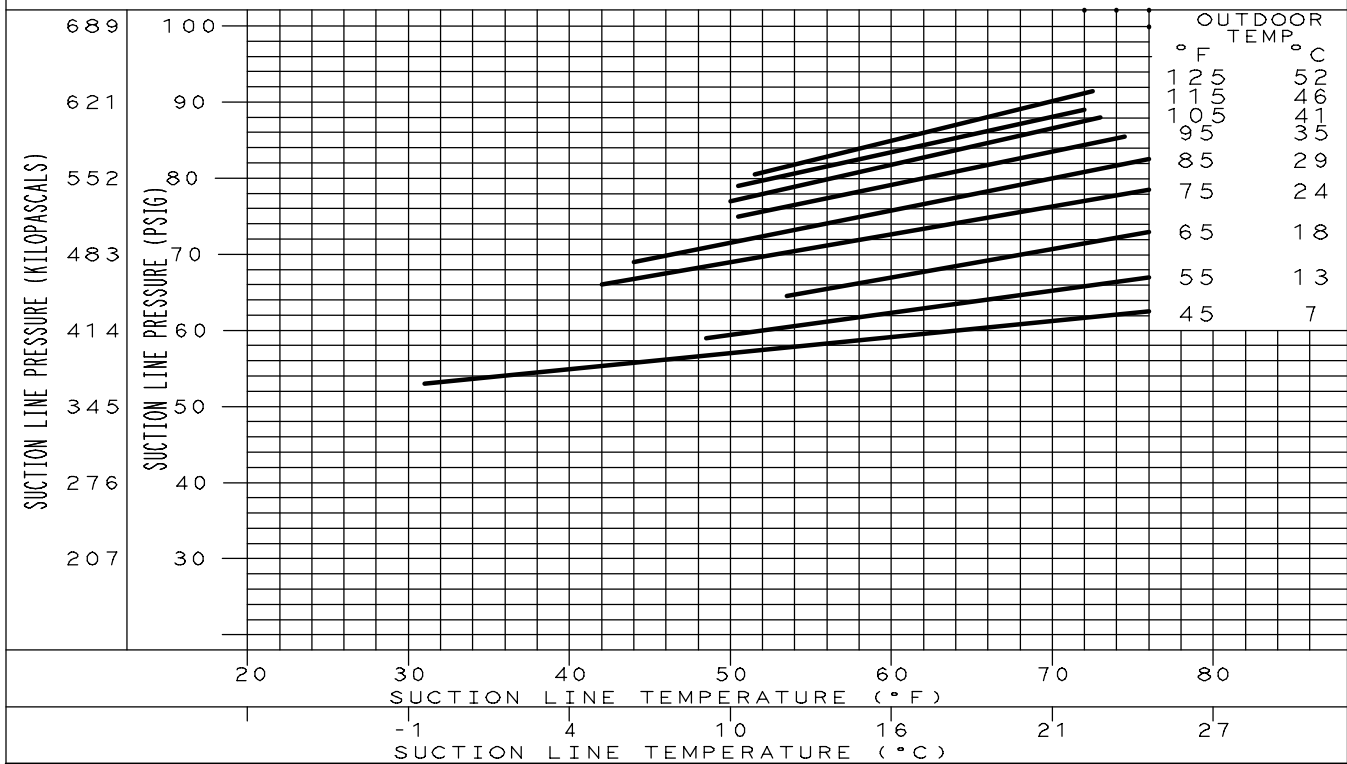

7.5 TON 60HZ (CIRCUIT #2) CHARGING CHART

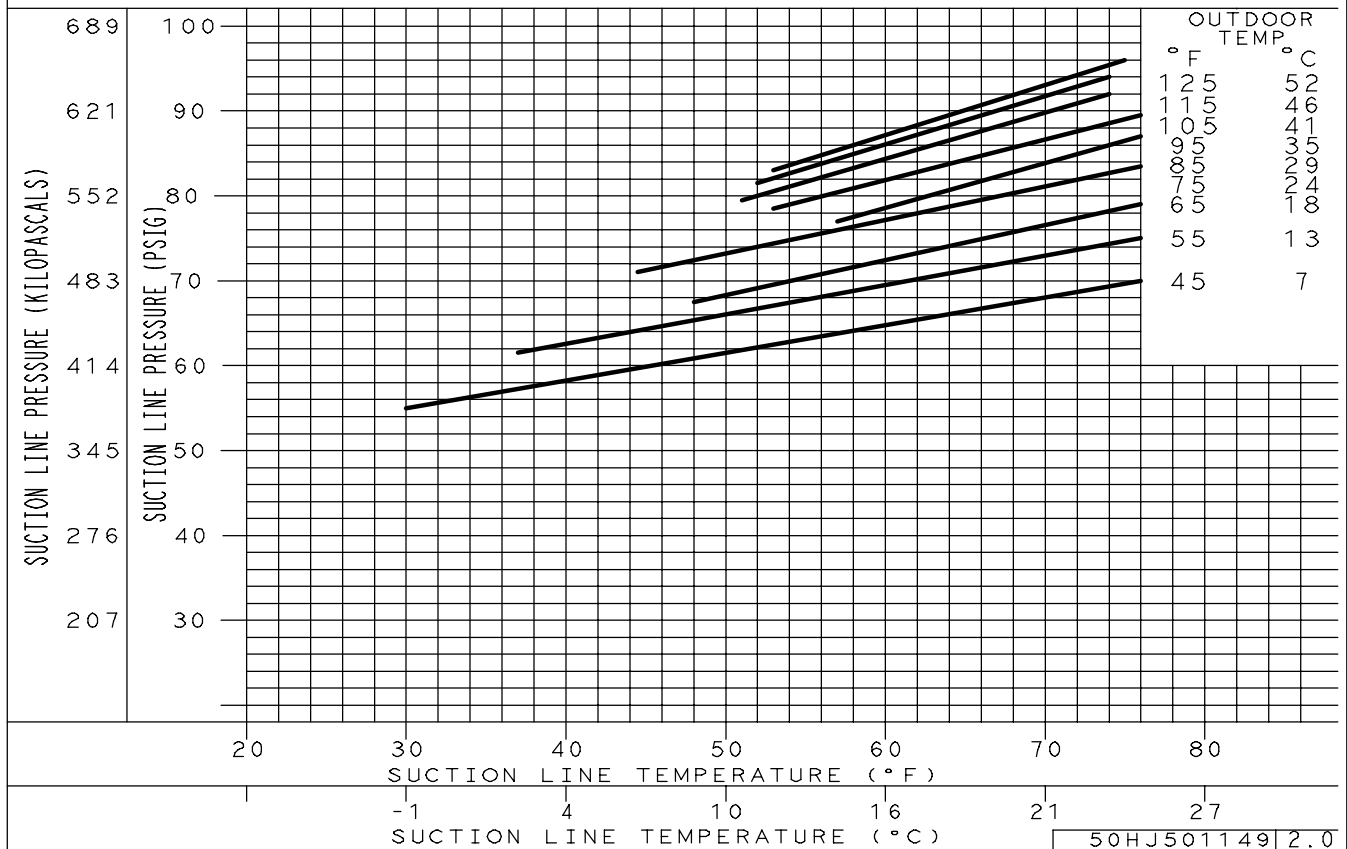

50HJ501149 | 2.0

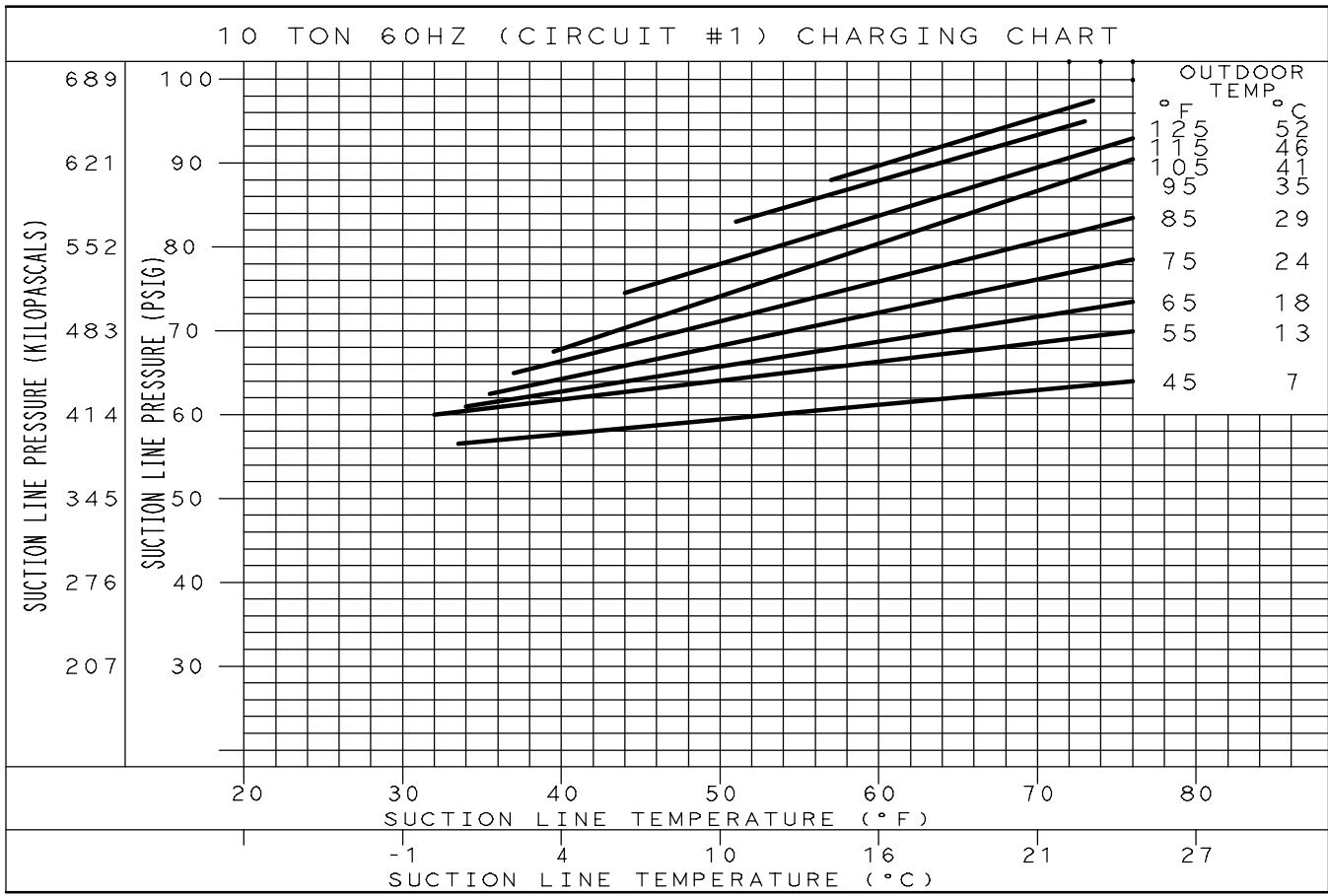
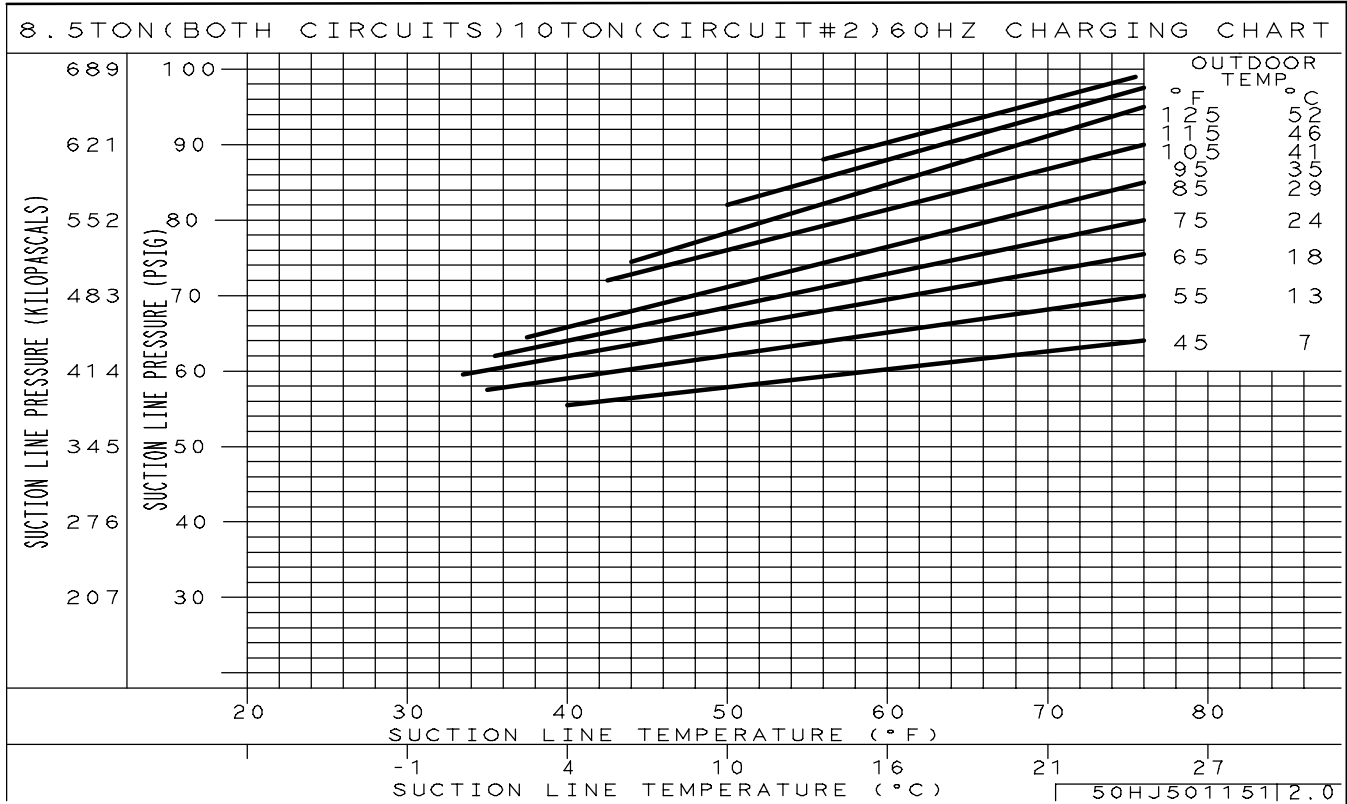

# PGH090-120

208/230-3-60  
SCHEMATIC

SEE NOTE #4

CIRCUIT BREAKER	VOLTS	MFG. PT. NO.	MUST TRIP AMPS
CB	24V	POTTER & BRUMFIELD W28X-1024-3.2	3.2
CB1 (014 STD)	208/230-3-60	HEINEMANN AIRPAX CF3-Z204-15 209-3-2599-485	17.3

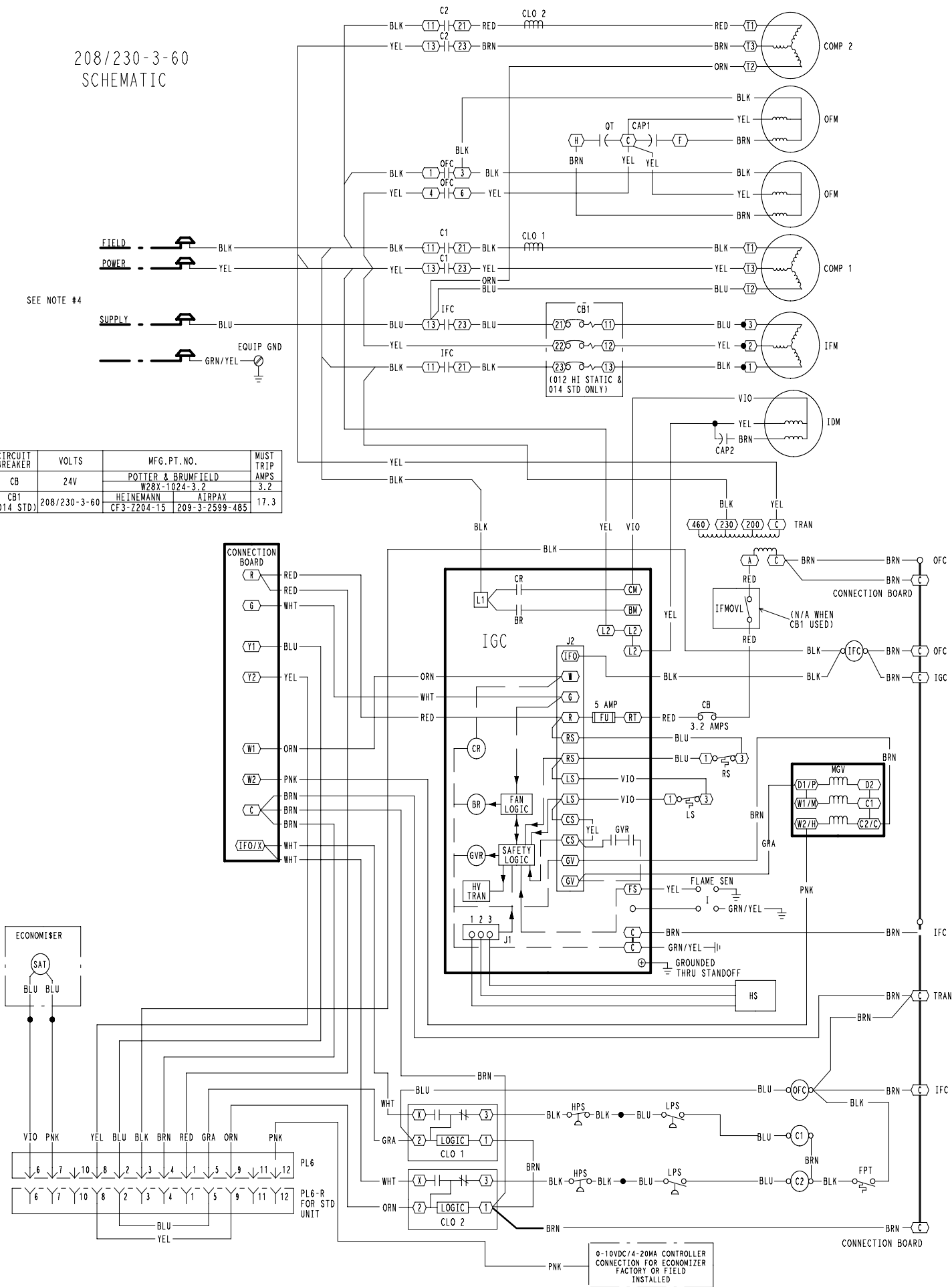

# PGH090-120

460-3-60  
SCHEMATIC

CIRCUIT BREAKER	VOLTS	MFG. PT. NO.		MUST TRIP AMPS
CB	24V	POTTER & BRUMFIELD		3.2
		W28X-1024-3-2		
CB1		HEINEMANN	AIRPAX	
(014 STD)	460-3-60	CF3-7228-41	219-3-2600-486	8.5

SEE NOTE #3

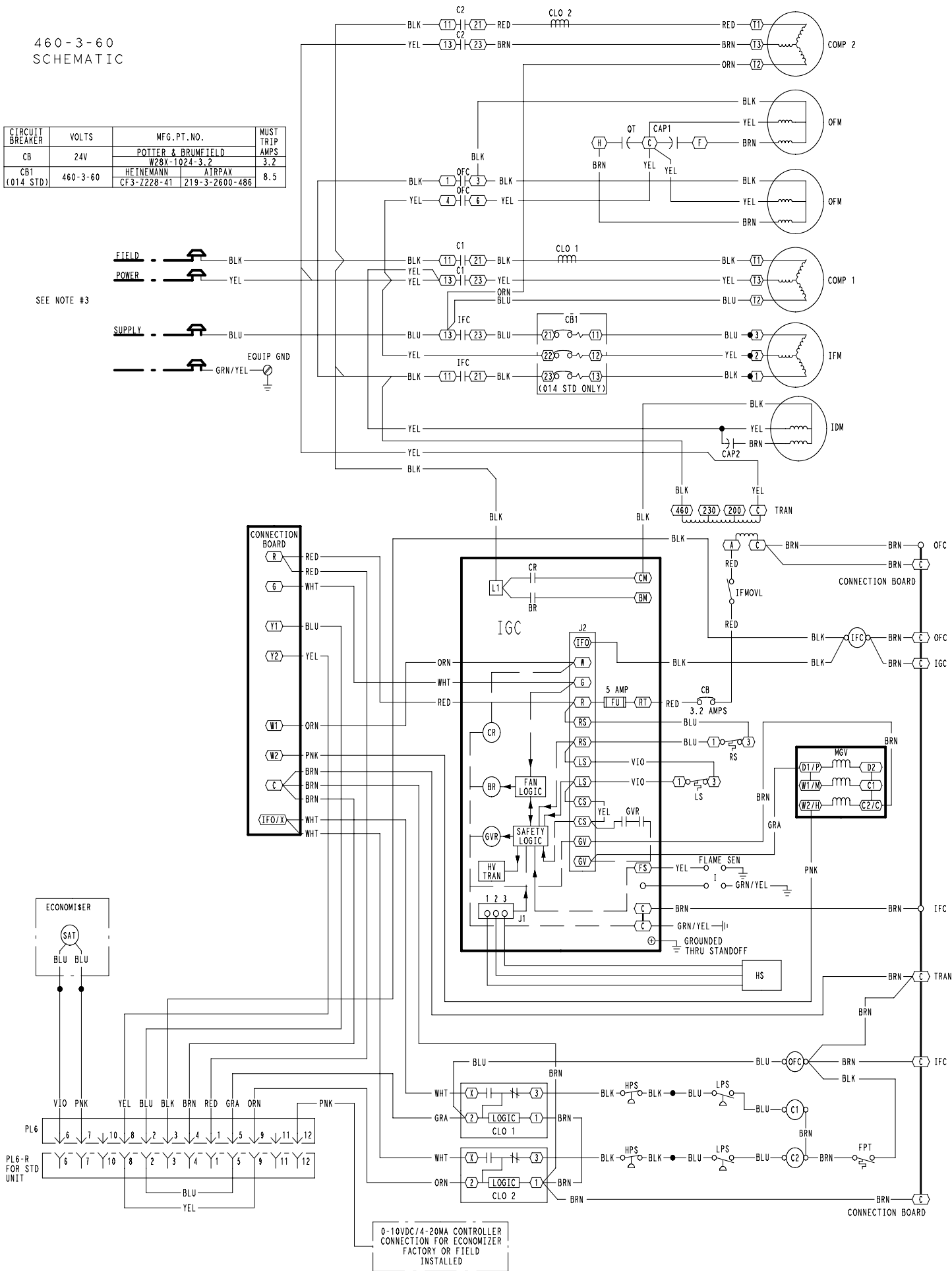

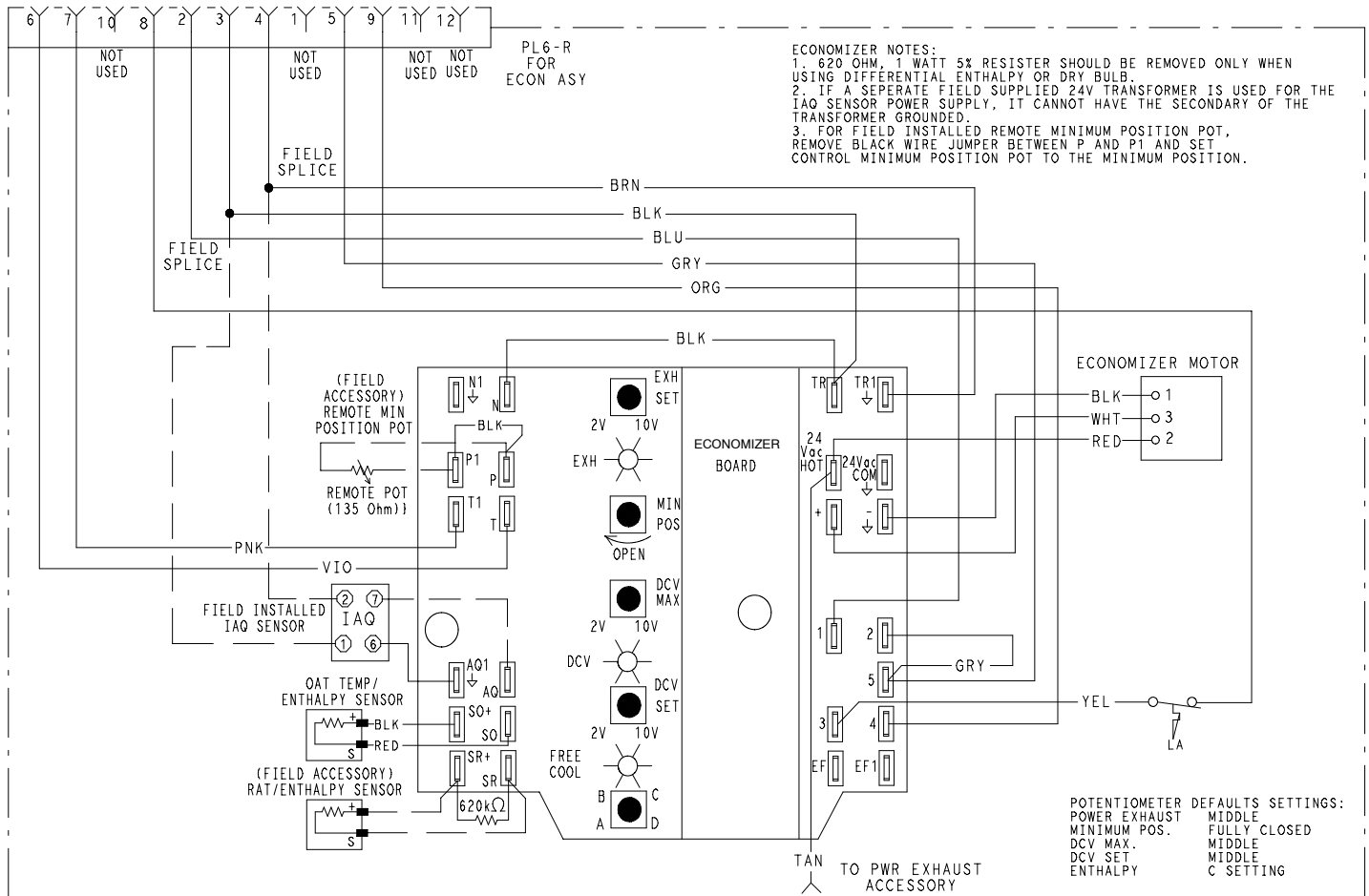

LEGEND

- FIELD SPLICE
- MARKED WIRE
- TERMINAL (MARKED)
- TERMINAL (UNMARKED)
- TERMINAL BLOCK
- SPLICE
- SPLICE (MARKED)
- FACTORY WIRING
- FIELD CONTROL WIRING
- FIELD POWER WIRING
- ACCESSORY OR OPTIONAL WIRING
- TO INDICATE COMMON POTENTIAL ONLY:  
NOT TO REPRESENT WIRING

NOTES 208/230V

1. IF ANY OF THE ORIGINAL WIRE FURNISHED MUST BE REPLACED. IT MUST BE REPLACED WITH TYPE 90 C WIRE OR ITS EQUIVALENT.
2. COMPRESSOR AND FAN MOTORS ARE THERMALLY PROTECTED. THREE PHASE MOTORS ARE PROTECTED AGAINST PRIMARY SINGLE PHASING CONDITIONS.
3. TRAN IS WIRED FOR 230V UNIT. IF UNIT IS TO BE RUN WITH 208V POWER SUPPLY DISCONNECT BLK WIRE FROM 230V TAP (ORN) AND CONNECT TO 208V TAP (RED). INSULATE END OF 230V WIRE.
4. USE COPPER CONDUCTOR ONLY.

NOTES 460V

1. IF ANY OF THE ORIGINAL WIRE FURNISHED MUST BE REPLACED. IT MUST BE REPLACED WITH TYPE 90 C WIRE OR ITS EQUIVALENT.
2. COMPRESSOR AND FAN MOTORS ARE THERMALLY PROTECTED. THREE PHASE MOTORS ARE PROTECTED AGAINST PRIMARY SINGLE PHASING CONDITIONS.
3. USE COPPER CONDUCTOR ONLY.

- C CONTACTOR, COMPRESSOR
- CB CIRCUIT BREAKER
- CH CRANKCASE HEATER
- CLO COMPRESSOR LOCKOUT
- COMP COMPRESSOR MOTOR
- EQUIP EQUIPMENT
- FPT FREEZE UP PROTECTION THERMOSTAT
- GND GROUND
- HPS HIGH PRESSURE SWITCH
- HS HALL EFFECT SEN.
- I IGNITOR
- IAQ INDOOR AIR QUALITY SEN.
- IARH INDOOR AIR RELATIVE HUMIDITY SEN.
- IDM INDUCED DRAFT MOTOR
- IFC INDOOR FAN CONTACTOR
- IFM INDOOR FAN MOTOR
- IFMOVL INDOOR FAN MOTOR OVERLOAD SWITCH
- IGC INTEGRATED GAS UNIT CONTROLLER
- LA LOW AMBIENT LOCKOUT
- LPS LOW PRESSURE SWITCH
- LS LIMIT SWITCH
- MGV MAIN GAS VALVE
- MTR MOTOR
- OARH OUTDOOR AIR RELATIVE HUMIDITY SEN.
- OAT OUTDOOR AIR TEMP. SEN.
- OFC OUTDOOR FAN CONTACTOR
- OFM OUTDOOR FAN MOTOR
- P PLUG
- PL PLUG ASSEMBLY
- POT POTENTIOMETER
- QT QUADRUPLE TERMINAL
- RAT RETURN AIR TEMP. SEN.
- RS ROLLOUT SWITCH
- SAT SUPPLY AIR TEMP. SEN.
- SEN SENSOR
- TRAN TRANSFORMER

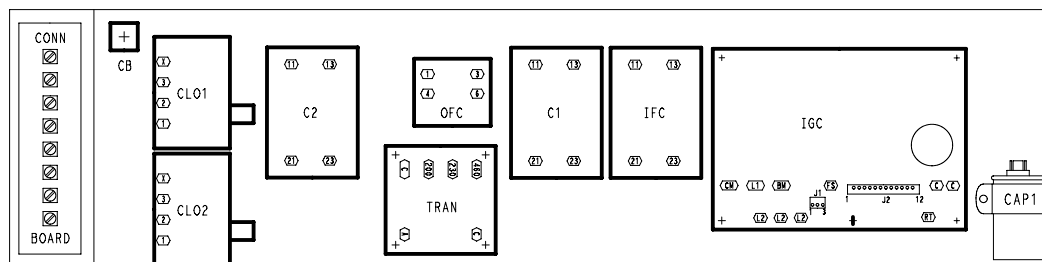

COMPONENT ARRANGEMENT

50HJ501296 | 7.0