

14 SEER, 12 EER, 8.0 HSPF, PACKAGE HEAT PUMP, 2 to 5 TONS

208/230-1-60, Single Phase

REFRIGERATION CIRCUIT

- Environmentally sound R-410A refrigerant
- Copper tube/aluminum fin condenser and evaporator coils
- Scroll compressor standard on all models
- Short-cycling protection for the compressor is built into the defrost control board
- Dehumidification mode (airflow reduction) on all models

EASY TO INSTALL AND SERVICE

- Installs easily on a rooftop or at ground level
- Easy three-panel accessibility for maintenance and installation
- Easily converts to down discharge applications
- Combination electric heating and cooling

BUILT TO LAST

- Hail guard (3/8" spacing) wire grilles standard on PHD3**000KTP models (2" spacing wire grilles on non-tin models)
- Direct drive high efficiency ECM blower motor on all models
- Pre-painted steel cabinet
- Vertical condenser fan discharge
- Full perimeter steel base rails
- High and low pressure switches provide added reliability for the compressor
- All models available with optional factory installed tin-coated copper evaporator coil (These models are identified with letters TP in the 11th and 12th positions in the model number)

WARRANTY*

- 5 year No Hassle Replacement™ limited warranty for models with tin coated copper evaporator coils
- 5 year parts limited warranty (including compressor and coils)
 - With timely registration, an additional 5 year parts limited warranty (including compressor and coils)

* Applies to original purchaser/homeowner, some limitations may apply. See warranty certificate for complete details.



As an Energy Star® Partner, International Comfort Products has determined that this product meets the ENERGY STAR® guidelines for energy efficiency.



Use of the AHRI Certified TM Mark indicates a manufacturer's participation in the program. For verification of certification for individual products, go to www.ahridirectory.org.

UNIT PERFORMANCE DATA							
Model Number	COOLING			HEATING		Unit Dimensions Height x Width x Depth in (mm)	Operating Weight lbs (kg)
	Capacity BTU/h	SEER	EER	Capacity BTU/h	HSPF		
PHD424000K000D	23,000	14.2	12.0	23,000	8.0	41 ⁷ / ₈ x 48 ³ / ₁₆ x 32 ⁵ / ₈ (1065 x 1224 x 829)	348 (158)
PHD424000KTP0D	23,000	14.2	12.0	23,000	8.0	41 ⁷ / ₈ x 48 ³ / ₁₆ x 32 ⁵ / ₈ (1065 x 1224 x 829)	348 (158)
PHD430000K000D	28,600	14.2	12.0	29,600	8.0	45 ⁷ / ₈ x 48 ³ / ₁₆ x 32 ⁵ / ₈ (1165 x 1224 x 829)	340 (154)
PHD430000KTP0D	28,600	14.2	12.0	29,600	8.0	45 ⁷ / ₈ x 48 ³ / ₁₆ x 32 ⁵ / ₈ (1165 x 1224 x 829)	340 (154)
PHD436000K000D	35,800	14.5	12.0	35,800	8.0	43 ⁷ / ₈ x 48 ³ / ₁₆ x 44 ¹ / ₈ (1116 x 1224 x 1123)	418 (190)
PHD436000KTP0D	35,800	14.5	12.0	35,800	8.0	43 ⁷ / ₈ x 48 ³ / ₁₆ x 44 ¹ / ₈ (1116 x 1224 x 1123)	418 (190)
PHD442000K000D	40,500	14.5	12.0	41,500	8.0	49 ⁷ / ₈ x 48 ³ / ₁₆ x 44 ¹ / ₈ (1266 x 1224 x 1123)	464 (210)
PHD442000KTP0D	40,500	14.5	12.0	41,500	8.0	49 ⁷ / ₈ x 48 ³ / ₁₆ x 44 ¹ / ₈ (1266 x 1224 x 1123)	464 (210)
PHD448000K000D	46,500	14.5	12.0	45,500	8.0	49 ⁷ / ₈ x 48 ³ / ₁₆ x 44 ¹ / ₈ (1266 x 1224 x 1123)	452 (205)
PHD448000KTP0D	46,500	14.5	12.0	45,500	8.0	49 ⁷ / ₈ x 48 ³ / ₁₆ x 44 ¹ / ₈ (1266 x 1224 x 1123)	452 (205)
PHD460000K000D	57,000	14.5	12.0	59,000	8.0	53 ⁷ / ₈ x 48 ³ / ₁₆ x 44 ¹ / ₈ (1368 x 1224 x 1123)	506 (230)
PHD460000KTP0D	57,000	14.5	12.0	59,000	8.0	53 ⁷ / ₈ x 48 ³ / ₁₆ x 44 ¹ / ₈ (1368 x 1224 x 1123)	506 (230)

MODEL NOMENCLATURE											
MODEL SERIES	1	2	3	4	5,6	7,8,9	10	11,12	13	14	15
	P	H	D	4	36	000	K	00	0	D	1
P = Package											
H = Heat Pump											
D = Standard											
TIER											
3 = 13											
4 = 14											
5 = 15											
SEER											
24 = 24,000 BTUH = 2 Tons											
30 = 30,000 BTUH = 2.5 Tons											
36 = 36,000 BTUH = 3 Tons											
42 = 42,000 BTUH = 3.5 Tons											
48 = 48,000 BTUH = 4 Tons											
60 = 60,000 BTUH = 5 Tons											
NOMINAL COOLING CAPACITY											
000 = no factory heat											
NOMINAL HEATING BTUH (input)											
K = 208/230-1-60											
VOLTAGE											
00 = No options											
TP = Tin Plated Evaporator Main Tubes											
FACTORY INSTALLED OPTIONS											
0 = Standard											
FEATURE CODE											
Sales Model Digit											
Engineering Digit											

AHRI* CAPACITIES

COOLING CAPACITIES AND EFFICIENCIES					
PHD4	NOMINAL TONS	STANDARD CFM	COOLING CAPACITY	EER	SEER
24	2	800	23000	12.0	14.2
30	2.5	1000	28600	12.0	14.2
36	3	1200	35800	12.0	14.5
42	3.5	1400	40500	12.0	14.5
48	4	1600	46500	12.0	14.5
60	5	1750	57000	12.0	14.5

HEAT PUMP HEATING CAPACITIES AND EFFICIENCIES					
PHD4	HEATING CAPACITY (BTUH) @ 47 °F (8.3 °C)	COP @ 47 °F (8.3 °C)	HEATING CAPACITY (BTUH) @ 17 °F (-8.3 °C)	COP @ 17 °F (-8.3 °C)	HSPF
24	23000	3.5	11400	2.2	8.0
30	29600	3.5	15400	2.2	8.0
36	35800	3.5	19800	2.2	8.0
42	41500	3.4	23000	2.3	8.0
48	45500	3.4	26000	2.3	8.0
60	59000	3.5	32000	2.3	8.0

LEGEND

dB—Sound Levels (decibels)

db—Dry Bulb

SEER—Seasonal Energy Efficiency Ratio

wb—Wet Bulb

COP—Coefficient of Performance

HSPF—Heating Season Performance Factor

* Air Conditioning, Heating, & Refrigeration Institute.

**At "A" conditions—80°F (26.7°C) indoor db/67°F (19.4°C) indoor wb & 95°F (35°C) outdoor db.

† Rated in accordance with U.S. Government DOE Department of Energy) test procedures and/or ARI Standards 210/240.

Notes:

1. Ratings are net values, reflecting the effects of circulating fan heat.

Ratings are based on:

Cooling Standard: 80°F (26.7°C) db, 67°F (19.4°C) wb indoor entering—air temperature and 95°F (35°C) db outdoor entering—air temperature.

2. Before purchasing this appliance, read important energy cost and efficiency information available from your retailer.

ELECTRICAL DATA – PHD4

MODEL	V-PH-HZ	RANGE		RLA	LRA	OFM	IFM	NOMINAL kW 208v/230v	FLA 208v/230v	MCA 208v/230v	MOCP 208v/230v
		MIN	MAX			FLA	FLA				
PHD424	208/230-1-60	197	253	13.5	58.3	0.7	4.1	-/-	-/-	21.7	30
								3.8/5	18.1/20.8	44.3/47.7	45/50
								5.4/7.2	25.9/30	54.1/59.2	60/60
								7.5/10	36.1/41.7	66.8/73.8	70/80
PHD430		197	253	14.1	73	1.2	4.1	-/-	-/-	22.9	35
								3.8/5	18.1/20.8	45.6/48.9	50/50
								5.4/7.2	25.9/30	55.3/60.4	60/70
								7.5/10	36.1/41.7	68.1/75.1	70/80
PHD436		197	253	17.1	79	1.2	6.0	-/-	-/-	28.6	40
								3.8/5	18.1/20.8	51.2/54.6	60/60
								5.4/7.2	25.9/30	61.0/66.1	70/70
								7.5/10	36.1/41.7	73.7/80.7	80/90
PHD442	197	253	20.6	112	1.2	6.0	-/-	-/-	33.0	50	
							3.8/5	18.1/20.8	55.6/59.0	60/60	
							5.4/7.2	25.9/30	65.3/70.5	70/80	
							7.5/10	36.1/41.7	78.1/85.1	80/90	
PHD448	197	253	23.4	109	1.2	7.6	-/-	-/-	38.1	50	
							3.8/5	18.1/20.8	60.7/64.1	70/70	
							5.4/7.2	25.9/30	70.4/75.6	80/80	
							7.5/10	36.1/41.7	83.2/90.2	90/100	
PHD460	197	253	29.6	134	1.2	7.6	-/-	-/-	45.8	60	
							3.8/5	18.1/20.8	68.4/71.8	70/80	
							5.4/7.2	25.9/30	78.2/83.3	80/90	
							7.5/10	36.1/41.7	90.9/97.9	100/100	
								11.3/15	54.2/62.5	113.6/123.9	125/125
								15/20	72.2/83.3	136.1/149.9	150/150

See Legend and Notes.

LEGEND

- FLA -- Full Load Amps
- LRA -- Locked Rotor Amps
- MCA -- Minimum Circuit Amps
- MOCP -- Maximum Overcurrent Protection
- RLA -- Rated Load Amps



NOTES:

1. In compliance with NEC (National Electrical Code) requirements for multimotor and combination load equipment (refer to NEC Articles 430 and 440), the overcurrent protective device for the unit shall be Power Supply fuse. The CGA (Canadian Gas Association) units may be fuse or circuit breaker.
2. Minimum wire size is based on 60 C copper wire. If other than 60 C wire is used, or if length exceeds wire length in table, determine size from NEC.

PHYSICAL DATA – UNIT PHD4						
UNIT SIZE	24	30	36	42	48	60
NOMINAL CAPACITY (ton)	2	2.5	3	3.5	4	5
Shipping Weight (lb)	354	346	426	472	460	506
(kg)	161	157	193	214	209	230
Compressor Quantity	1					
Type	Scroll					
Refrigerant	R-410A					
Refrigerant Quantity (lb)	11.1	10.3	9.9	11.3	12.5	15.2
Quantity (kg)	5.0	4.7	4.5	5.1	5.7	6.9
Refrigerant Metering Device	Indoor TXV, Outdoor Dual Orifice					
Orifice OD (in)	0.032 (2)	0.037 (2)	0.038 (2)	0.040 (2)	0.040 (2)	0.049 (2)
(mm)	0.81 (2)	0.94 (2)	0.97 (2)	1.02 (2)	1.02 (2)	1.24 (2)
Outdoor Coil Rows...Fins/in, face area (sq. ft.)	2...21 13.6	2...21 13.6	2...21 13.6	2...21 17.5	2...21 17.5	2...21 23.3
Outdoor Fan Nominal Airflow (cfm)	2500	2700	3100	3100	3100	3500
Diameter (in.)	24	24	26	26	26	26
Diameter (mm)	610	610	660	660	660	660
Motor hp (rpm)	1/10 (810)	1/5 (810)	1/5 (810)	1/5 (810)	1/5 (810)	1/4 (810)
Indoor Coil Rows...Fins/in, face area (sq. ft.)	3...17 3.7	3...17 3.7	3...17 4.7	3...17 4.7	3...17 5.6	3...17 5.6
Indoor Blower Nominal Airflow (cfm)	800	1000	1200	1400	1600	1750
Size (in.)	10 x 10	10 x 10	11 x 10	11 x 10	11 x 10	11 x 10
Size (mm)	254 x 254	254 x 254	279 x 254	279 x 254	279 x 254	279 x 254
Motor hp (rpm)	1/2	1/2	3/4	3/4	1	1
High Pressure Switch (psig) Cutout	650 +/- 15					
Reset (Auto)	420 +/- 25					
Loss-of-Charge/Low Pressure Switch (psig) Cutout	20 +/- 5					
Reset (Auto)	45 +/- 10					
Return Air Filters disposable (in) (mm)	20x20x1 508x508x25	20x24x1 508x610x25	24x30x1 610x762x25		24x36x1 610x914x25	

*Required filter sizes shown are based on the larger of the AHRI (Air conditioning, Heating, and Refrigeration Institute) rated cooling airflow or the heating airflow velocity of 300 ft/minute for throwaway type or 450 ft/minute for high-capacity type. Air filter pressure drop for non-standard filters must not exceed 0.08 IN. W.C.

† If using accessory filter rack refer to the filter rack installation instructions for correct filter size and quantity.

A-WEIGHTED SOUND POWER LEVEL (dBA)								
MODEL PHD4	STANDARD RATING (dBA)	TYPICAL OCTAVE BAND SPECTRUM (dBA) (without tone adjustment)						
		125	250	500	1000	2000	4000	8000
24	74	67.0	65.5	68.5	68.0	63.5	59.5	53.5
30	72	61.5	62.5	66.0	66.0	63.0	57.5	50.5
36	78	62.0	69.0	72.5	73.0	70.5	67.5	62.0
42	75	62.5	62.5	68.5	70.0	67.0	62.0	58.5
48	78	70.5	69.5	71.0	72.5	69.5	66.0	59.5
60	79	69.0	69.0	71.5	74.0	72.0	67.5	59.5

NOTE: Tested in accordance with AHRI Standard 270 (not listed in AHRI).

DRY COIL AIR DELIVERY* – HORIZONTAL AND DOWNFLOW DISCHARGE – UNIT PHD424–60

Unit	Motor Speed	Wire Color	cfm	External Static Pressure (in W.C)										
				0.1	0.2	0.3	0.4	0.5	0.6	0.7	0.8	0.9		
PHD424	Low	Blue	cfm	754	650	536	429	---	---	---	---	---	---	---
	Med-Low	Pink	cfm	851	777	675	591	475	---	---	---	---	---	---
	Medium ¹	Red	cfm	941	851	774	684	576	479	---	---	---	---	---
	Med-High	Orange	cfm	1009	917	840	759	667	577	447	---	---	---	---
	High	Black	cfm	1241	1167	1111	1036	969	881	818	731	640	---	---
PHD430	Low	Blue	cfm	741	638	547	415	---	---	---	---	---	---	---
	Med-Low	Pink	cfm	973	887	823	733	665	538	451	---	---	---	---
	Medium	Red	cfm	1088	1023	954	881	800	723	658	563	461	---	---
	Med-High ¹	Orange	cfm	1140	1064	996	915	840	758	687	564	480	---	---
	High	Black	cfm	1202	1140	1082	1015	961	881	810	732	631	---	---
PHD436	Low	Blue	cfm	1176	1121	1079	1019	974	920	877	826	754	---	---
	Med-Low	Pink	cfm	1295	1234	1182	1126	1075	1016	955	898	857	---	---
	Medium ¹	Red	cfm	1345	1282	1235	1194	1140	1095	1027	974	921	---	---
	Med-High	Orange	cfm	1505	1452	1413	1358	1323	1282	1234	1169	1130	---	---
	High	Black	cfm	1705	1643	1607	1568	1518	1483	1448	1404	1360	---	---
PHD442	Low	Blue	cfm	1295	1234	1182	1126	1075	1016	955	898	857	---	---
	Med-Low	Pink	cfm	1345	1282	1235	1194	1140	1095	1027	974	921	---	---
	Medium	Red	cfm	1505	1452	1413	1358	1323	1282	1234	1169	1130	---	---
	Med-High ¹	Orange	cfm	1545	1492	1449	1411	1362	1313	1278	1231	1188	---	---
	High	Black	cfm	1705	1643	1607	1568	1518	1483	1448	1404	1360	---	---
PHD448	Low	Blue	cfm	1430	1374	1327	1267	1223	1176	1127	1061	1016	---	---
	Med-Low	Pink	cfm	1445	1389	1341	1281	1236	1189	1139	1072	1027	---	---
	Medium ¹	Red	cfm	1678	1635	1602	1558	1513	1474	1438	1404	1349	---	---
	Med-High	Orange	cfm	2131	2088	2065	2013	1982	1941	1888	1860	1785	---	---
	High	Black	cfm	2461	2409	2339	2286	2192	2140	2062	1968	1874	---	---
PHD460	Low	Blue	cfm	1445	1389	1341	1281	1236	1189	1139	1072	1027	---	---
	Med-Low	Pink	cfm	1678	1635	1602	1558	1513	1474	1438	1404	1349	---	---
	Medium ¹	Red	cfm	1962	1915	1880	1843	1794	1753	1711	1675	1628	---	---
	Med-High	Orange	cfm	2131	2088	2065	2013	1982	1941	1888	1860	1785	---	---
	High	Black	cfm	2461	2409	2339	2286	2192	2140	2062	1968	1874	---	---

* Air delivery values are without air filter and are for dry coil (See PHD4–A Wet Coil Pressure Drop Table).

¹ Factory–shipped cooling/heat pump heating speed

NOTE: For horizontal applications deduct field–supplied air filter pressure drop and wet coil pressure drop to obtain external static pressure available for ducting. For downflow applications see Wet Coil Air Delivery table for available static including wet coil, 1–in. (25 mm) filter and economizer.

Shaded areas indicate speed/static combinations that are not permitted for dehumidification speed.

HORIZONTAL WET COIL PRESSURE DROP (in wc)

UNIT SIZE	STANDARD CFM (S.C.F.M)															
	500	600	700	800	900	1000	1100	1200	1300	1400	1500	1600	1700	1800	1900	2000
24		0.06	0.07	0.08	0.09	0.1										
30				0.12	0.15	0.19	0.23	0.27								
36						0.07	0.11	0.18	0.26	0.35						
42								0.04	0.07	0.1	0.15	0.21				
48										0.11	0.14	0.17	0.22	0.28		
60												0.1	0.17	0.23	0.31	0.36

WET COIL AIR DELIVERY (CFM) – DOWNFLOW – HIGH SPEED WITH 1–IN. (25 MM) FILTER AND ECONOMIZER

UNIT SIZE	EXTERNAL STATIC PRESSURE (in. W.C.)										
	0.1	0.2	0.3	0.4	0.5	0.6	0.7	0.8	0.9	1.0	
36, 42	1612	1569	1527	1481	1451	1393	1351	1317	1278	1242	
48	2298	2239	2180	2110	2044	1951	1862	1777	1697	1591	
60	2000	1926	1825	1820	1759	1705	1634	1496	1412	1328	

HORIZONTAL FILTER PRESSURE DROP TABLE (in wc)

FILTER SIZE in. (mm)	STANDARD CFM (S.C.F.M)																		
	500	600	700	800	900	1000	1100	1200	1300	1400	1500	1600	1700	1800	1900	2000	2100	2200	2300
20X20X1 (508X508X25)	0.05	0.07	0.08	0.1	0.12	0.13	0.14	0.15	—	—	—	—	—	—	—	—	—	—	—
20X24X1 (508X610x25)	—	—	—	.09	.10	.11	.13	.14	.15	.16	—	—	—	—	—	—	—	—	—
24X30X1 (610X762x25)	—	—	—	0.04	0.05	0.06	0.07	0.07	0.08	0.09	0.1	—	—	—	—	—	—	—	—
24X36X1 (610X914X25)	—	—	—	—	—	—	—	0.06	0.07	0.07	0.08	0.09	0.09	0.10	0.11	0.12	0.13	0.14	0.14

ECONOMIZER 1-IN. (25 MM) FILTER PRESSURE DROP (in wc)

UNIT PHD4	PRESSURE DROP
24-30	0.20
36-60	0.25

MULTIPLICATION FACTORS

HEATER kW RATING	VOLTAGE DISTRIBUTION	MULTIPLICATION FACTOR
240	200	0.69
	208	0.75
	230	0.92
	240	1.00

ELECTRIC HEAT PRESSURE DROP TABLE (in wc) SMALL CABINET: 24-30

HEATER CAPACITY	STANDARD CFM (S.C.F.M)											
	500	600	700	800	900	1000	1100	1200	1300	1400	1500	1600
5kw	0.00	0.00	0.00	0.00	0.00	0.00	0.00	0.00	0.02	0.04	0.06	0.07
7.5 kw	0.00	0.00	0.00	0.00	0.00	0.00	0.02	0.03	0.05	0.07	0.08	0.09
10 kw	0.00	0.00	0.00	0.00	0.00	0.02	0.04	0.06	0.07	0.09	0.10	0.11
15 kw	0.00	0.00	0.00	0.02	0.04	0.06	0.08	0.10	0.12	0.14	0.16	0.18

ELECTRIC HEAT PRESSURE DROP TABLE (in wc) LARGE CABINET 36-60

HEATER CAPACITY	STANDARD CFM (S.C.F.M)														
	1100	1200	1300	1400	1500	1600	1700	1800	1900	2000	2100	2200	2300	2400	2500
5kw	0.00	0.00	0.00	0.01	0.02	0.03	0.04	0.05	0.06	0.07	0.08	0.09	0.10	0.11	0.12
7.5 kw	0.00	0.00	0.01	0.02	0.03	0.04	0.05	0.06	0.07	0.08	0.09	0.10	0.11	0.12	0.13
10 kw	0.00	0.00	0.01	0.02	0.03	0.04	0.05	0.06	0.07	0.08	0.09	0.10	0.11	0.12	0.13
15 kw	0.00	0.02	0.03	0.04	0.05	0.06	0.07	0.08	0.09	0.10	0.11	0.12	0.13	0.14	0.15
20 kw	0.02	0.03	0.04	0.05	0.06	0.07	0.08	0.09	0.10	0.11	0.12	0.13	0.14	0.15	0.16

MINIMUM AIRFLOW FOR RELIABLE ELECTRIC HEATER OPERATION (CFM)

SIZE	PHD424	PHD430	PHD436	PHD442	PHD448	PHD460
AIRFLOW (CFM)	800	1025	1250	1400	1710	1800

PHD424 COOLING EXTENDED PERFORMANCE TABLE																			
EVAPORATOR AIR		CONDENSER ENTERING AIR TEMPERATURES °F (°C)																	
		75 (23.9)			85 (29.4)			95 (35)			105 (40.6)			115 (46.1)			125 (51.7)		
		Capacity MBtuh		Total Sys KW	Capacity MBtuh		Total Sys KW	Capacity MBtuh		Total Sys KW	Capacity MBtuh		Total Sys KW	Capacity MBtuh		Total Sys KW	Capacity MBtuh		Total Sys KW
CFM / BF	EWB °F (°C)	Total	Sens	Total	Sens	Total	Sens	Total	Sens	Total	Sens	Total	Sens	Total	Sens	Total	Sens	Total	Sens
		700 / 0.08	57 (13.8)	23.20	23.20	1.51	21.79	21.79	1.69	20.35	20.35	1.90	18.87	18.87	2.12	17.34	17.34	2.36	15.72
62 (16.6)	23.89		22.10	1.51	22.26	20.78	1.69	20.63	19.47	1.90	18.99	18.11	2.12	17.35	17.35	2.36	15.72	15.72	2.63
63* (17.2)	24.22		17.97	1.51	22.54	16.83	1.69	20.86	15.71	1.90	19.15	14.59	2.12	17.40	13.47	2.36	15.56	12.33	2.63
67 (19.4)	26.13		18.68	1.51	24.33	17.52	1.69	22.51	16.37	1.90	20.66	15.25	2.12	18.76	14.06	2.37	16.75	12.87	2.63
72 (22.2)	28.61		15.23	1.51	26.64	14.20	1.70	24.63	13.18	1.90	22.59	12.15	2.13	20.48	11.12	2.37	18.24	10.05	2.63
800 / 0.09	57 (13.8)	24.24	24.24	1.53	22.73	22.73	1.71	21.20	21.20	1.91	19.62	19.62	2.14	18.00	18.00	2.38	16.26	16.26	2.64
	62 (16.6)	24.56	23.69	1.53	22.89	22.23	1.71	21.22	21.22	1.91	19.62	19.62	2.14	18.00	18.00	2.38	16.26	16.26	2.64
	63* (17.2)	24.83	19.13	1.53	23.09	17.95	1.71	21.33	16.77	1.91	19.55	15.59	2.14	17.72	14.39	2.38	15.82	13.15	2.64
	67 (19.4)	26.77	19.94	1.53	24.90	18.72	1.71	23.00	17.50	1.92	21.07	16.28	2.14	19.09	15.05	2.38	17.00	13.78	2.65
	72 (22.2)	29.30	16.01	1.53	27.24	14.94	1.72	25.15	13.87	1.92	23.02	12.79	2.14	21.99	12.21	2.11	18.49	10.58	2.65
900 / 0.10	57 (13.8)	25.13	25.13	1.54	23.54	23.54	1.73	21.92	21.92	1.93	20.26	20.26	2.16	18.53	18.53	2.40	16.69	16.69	2.66
	62 (16.6)	25.17	25.17	1.54	23.54	23.54	1.73	21.92	21.92	1.93	20.26	20.26	2.16	18.53	18.53	2.40	16.70	16.70	2.66
	63* (17.2)	25.31	20.26	1.54	23.51	19.02	1.73	21.70	17.77	1.93	19.86	16.52	2.16	17.98	15.25	2.40	16.03	13.93	2.66
	67 (19.4)	27.29	21.14	1.55	25.34	19.86	1.73	23.38	18.58	1.93	21.38	17.30	2.16	19.34	15.99	2.40	17.19	14.61	2.66
	72 (22.2)	29.85	16.75	1.55	27.72	15.64	1.73	25.55	14.52	1.94	23.35	13.40	2.16	22.34	12.76	2.13	18.67	11.09	2.66

*At 75°F (23.9 °C) entering dry bulb—Tennessee Valley Authority [TVA] rating conditions; all others at 80°F (26.7 °C) entering dry bulb. See Legend and Notes.

PHD424 HEATING EXTENDED PERFORMANCE TABLE -10-60 (-23.3-15.6_C)																									
INDOOR AIR		OUTDOOR COIL ENTERING AIR TEMPERATURES °F (°C)																							
		-10 (-23.3)		0 (-17.8)		10 (-12.2)		20 (-6.7)		30 (-1.1)		40 (4.4)		50 (10)		60 (15.6)									
		Capacity MBtuh		Total Sys KW	Capacity MBtuh		Total Sys KW	Capacity MBtuh		Total Sys KW	Capacity MBtuh		Total Sys KW	Capacity MBtuh		Total Sys KW	Capacity MBtuh		Total Sys KW						
EDB	CFM	Total	Integ	Total	Integ	Total	Integ	Total	Integ	Total	Integ	Total	Integ	Total	Integ	Total	Integ	Total	Integ	Total	Integ	Total	Integ		
		65	700	7.36	6.77	1.58	9.63	8.86	1.63	12.04	11.05	1.68	14.61	13.25	1.74	17.53	15.36	1.81	20.88	20.88	1.90	24.68	24.68	2.02	29.14
800	7.48		6.88	1.58	9.76	8.98	1.62	12.18	11.18	1.67	14.77	13.40	1.72	17.76	15.56	1.78	21.18	21.18	1.86	25.22	25.22	1.96	29.17	29.17	2.09
900	7.58		6.97	1.59	9.86	9.07	1.62	12.30	11.29	1.66	14.92	13.53	1.70	17.99	15.76	1.76	21.51	21.51	1.84	25.23	25.23	1.93	28.82	28.82	2.06
70	700	7.07	6.50	1.66	9.38	8.63	1.71	11.80	10.83	1.77	14.39	13.05	1.83	17.25	15.12	1.91	20.57	20.57	2.00	24.27	24.27	2.12	28.75	28.75	2.27
	800	7.18	6.61	1.66	9.50	8.75	1.71	11.94	10.96	1.76	14.55	13.20	1.81	17.47	15.31	1.88	20.85	20.85	1.96	24.78	24.78	2.07	28.90	28.90	2.19
	900	7.28	6.70	1.67	9.61	8.85	1.71	12.07	11.08	1.75	14.68	13.32	1.80	17.66	15.47	1.85	21.09	21.09	1.93	25.00	25.00	2.03	28.67	28.67	2.16
75	700	6.74	6.20	1.74	9.10	8.38	1.80	11.56	10.61	1.87	14.17	12.85	1.93	16.98	14.88	2.01	20.27	20.27	2.11	23.90	23.90	2.23	28.30	28.30	2.39
	800	6.86	6.31	1.74	9.23	8.50	1.80	11.70	10.74	1.85	14.33	12.99	1.91	17.19	15.06	1.98	20.53	20.53	2.06	24.32	24.32	2.17	28.58	28.58	2.30
	900	6.96	6.41	1.75	9.35	8.60	1.80	11.82	10.85	1.84	14.46	13.12	1.89	17.37	15.22	1.95	20.76	20.76	2.04	24.73	24.73	2.14	28.48	28.48	2.27

See Legend and Notes following tables.

PHD430 COOLING EXTENDED PERFORMANCE TABLE

EVAPORATOR AIR		CONDENSER ENTERING AIR TEMPERATURES °F (°C)																	
		75 (23.9)			85 (29.4)			95 (35)			105 (40.6)			115 (46.1)			125 (51.7)		
		Capacity MBtuh		Total Sys KW	Capacity MBtuh		Total Sys KW	Capacity MBtuh		Total Sys KW	Capacity MBtuh		Total Sys KW	Capacity MBtuh		Total Sys KW	Capacity MBtuh		Total Sys KW
CFM / BF	EWB °F (°C)	Total	Sens	Total Sys KW	Total	Sens	Total Sys KW	Total	Sens	Total Sys KW	Total	Sens	Total Sys KW	Total	Sens	Total Sys KW	Total	Sens	Total Sys KW
		875 / 0.05	57 (13.8)		28.47	28.47		1.94	27.21		27.21	2.15		25.85	25.85		2.37	24.39	
62 (16.6)	29.18		25.42	1.94	27.67	24.95	2.15	26.09	24.39	2.37	24.42	24.42	2.62	22.78	22.78	2.88	20.95	20.95	3.15
63* (17.2)	29.61		20.60	1.94	28.05	20.16	2.15	26.40	19.65	2.38	24.64	19.08	2.62	22.73	18.41	2.88	20.62	17.62	3.15
67 (19.4)	31.91		21.40	1.95	30.23	20.96	2.16	28.45	20.46	2.38	26.52	19.88	2.63	24.44	19.21	2.89	22.12	18.39	3.16
72 (22.2)	34.97		17.28	1.96	33.11	16.85	2.17	31.12	16.32	2.39	28.99	15.72	2.64	26.68	15.03	2.90	24.10	14.20	3.17
1000 / 0.05	57 (13.8)	29.72	29.72	1.98	28.36	28.36	2.18	26.91	26.91	2.41	25.32	25.32	2.65	23.58	23.58	2.91	21.60	21.60	3.19
	62 (16.6)	29.97	27.26	1.98	28.41	28.34	2.18	26.91	26.91	2.41	25.33	25.33	2.65	23.58	23.58	2.91	21.60	21.60	3.19
	63* (17.2)	30.31	21.98	1.98	28.67	21.52	2.18	26.94	21.00	2.41	25.10	20.40	2.65	23.10	19.69	2.91	20.89	18.83	3.18
	67 (19.4)	32.64	22.87	1.99	30.88	22.42	2.19	29.00	21.90	2.42	26.98	21.29	2.66	24.80	20.58	2.92	22.39	19.70	3.19
	72 (22.2)	35.74	18.21	2.00	33.79	17.74	2.20	31.70	17.19	2.43	29.47	16.56	2.67	27.04	15.84	2.93	24.35	14.99	3.20
1125 / 0.06	57 (13.8)	30.79	30.79	2.01	29.34	29.34	2.22	27.78	27.78	2.44	26.09	26.09	2.69	24.23	24.23	2.95	22.12	22.12	3.22
	62 (16.6)	30.79	30.79	2.01	29.34	29.34	2.22	27.79	27.79	2.44	26.09	26.09	2.69	24.23	24.23	2.95	22.12	22.12	3.22
	63* (17.2)	30.85	23.30	2.01	29.15	22.83	2.22	27.36	22.29	2.44	25.44	21.65	2.68	23.38	20.89	2.94	21.11	19.95	3.21
	67 (19.4)	33.20	24.29	2.02	31.37	23.82	2.23	29.41	23.28	2.45	27.32	22.64	2.69	25.06	21.88	2.95	22.58	20.93	3.22
	72 (22.2)	36.33	19.07	2.03	34.30	18.58	2.24	32.12	18.01	2.46	29.81	17.37	2.70	27.30	16.63	2.96	24.52	15.74	3.23

*At 75°F (23.9 °C) entering dry bulb—Tennessee Valley Authority [TVA] rating conditions; all others at 80°F (26.7 °C) entering dry bulb. See Legend and Notes.

SPECIFICATIONS SUBJECT TO CHANGE WITHOUT NOTICE

PHD430 HEATING EXTENDED PERFORMANCE TABLE

INDOOR AIR		OUTDOOR COIL ENTERING AIR TEMPERATURES °F (°C)																															
		-10 (-23.3)				0 (-17.8)				10 (-12.2)				20 (-6.7)				30 (-1.1)				40 (4.4)				50 (10)				60 (15.6)			
		Capacity MBtuh		Total Sys KW	Capacity MBtuh		Total Sys KW	Capacity MBtuh		Total Sys KW	Capacity MBtuh		Total Sys KW	Capacity MBtuh		Total Sys KW	Capacity MBtuh		Total Sys KW	Capacity MBtuh		Total Sys KW	Capacity MBtuh		Total Sys KW	Capacity MBtuh		Total Sys KW					
EDB	CFM	Total	Integ	Total Sys KW	Total	Integ	Total Sys KW	Total	Integ	Total Sys KW	Total	Integ	Total Sys KW	Total	Integ	Total Sys KW	Total	Integ	Total Sys KW	Total	Integ	Total Sys KW	Total	Integ	Total Sys KW								
		65	875		9.06	8.34		1.90	12.11		11.14	1.98		15.26	14.00		2.04	18.55		16.82	2.12		22.03	19.31		2.19	25.87	25.87	2.28	30.37	30.37	2.39	35.63
1000	9.26		8.52	1.92	12.33	11.34	1.99	15.48	14.21	2.05	18.79	17.05	2.10	22.30	19.54	2.17	26.34	26.34	2.24	30.84	30.84	2.34	36.27	36.27	2.47								
1125	9.43		8.68	1.94	12.51	11.51	2.00	15.68	14.39	2.05	19.00	17.24	2.10	22.53	19.74	2.16	26.65	26.65	2.22	31.24	31.24	2.31	36.86	36.86	2.43								
70	875	8.53	7.85	1.98	11.67	10.73	2.06	14.87	13.65	2.14	18.21	16.51	2.22	21.71	19.03	2.30	25.47	25.47	2.40	29.91	29.91	2.52	35.05	35.05	2.67								
	1000	8.73	8.03	2.00	11.89	10.94	2.08	15.11	13.87	2.14	18.46	16.74	2.21	21.99	19.26	2.28	25.82	25.82	2.36	30.36	30.36	2.46	35.68	35.68	2.59								
	1125	8.91	8.20	2.02	12.08	11.11	2.09	15.31	14.05	2.15	18.68	16.94	2.21	22.22	19.47	2.27	26.12	26.12	2.34	30.74	30.74	2.42	36.20	36.20	2.55								
75	875	7.95	7.31	2.06	11.18	10.29	2.15	14.45	13.27	2.24	17.84	16.18	2.33	21.38	18.73	2.42	25.11	25.11	2.52	29.46	29.46	2.64	34.49	34.49	2.80								
	1000	8.15	7.50	2.08	11.40	10.49	2.17	14.70	13.49	2.24	18.10	16.41	2.32	21.66	18.97	2.39	25.43	25.43	2.48	29.90	29.90	2.58	35.09	35.09	2.72								
	1125	8.33	7.66	2.11	11.60	10.67	2.18	14.90	13.68	2.25	18.32	16.61	2.32	21.89	19.18	2.38	25.72	25.72	2.45	30.27	30.27	2.55	35.60	35.60	2.67								

See Legend and Notes following tables.

PHD436 COOLING EXTENDED PERFORMANCE TABLE																				
EVAPORATOR AIR		CONDENSER ENTERING AIR TEMPERATURES °F (°C)																		
		75 (23.9)			85 (29.4)			95 (35)			105 (40.6)			115 (46.1)			125 (51.7)			
CFM / BF	EWB °F (°C)	Capacity MBtuh		Total Sys KW	Capacity MBtuh		Total Sys KW	Capacity MBtuh		Total Sys KW	Capacity MBtuh		Total Sys KW	Capacity MBtuh		Total Sys KW	Capacity MBtuh		Total Sys KW	
		Total	Sens		Total	Sens		Total	Sens		Total	Sens		Total	Sens		Total	Sens		
1050 / 0.08	57 (13.8)	38.00	38.00	2.44	34.81	34.81	2.69	31.68	31.68	2.95	28.58	28.58	3.23	25.51	25.51	3.53	22.43	22.43	3.85	
	62 (16.6)	39.23	34.90	2.45	35.69	32.70	2.69	32.23	30.51	2.95	28.85	28.27	3.23	25.55	25.55	3.53	22.43	22.43	3.85	
	63* (17.2)	39.74	28.36	2.45	36.13	26.48	2.69	32.59	24.60	2.95	29.11	22.76	3.24	25.68	20.90	3.53	22.28	19.03	3.85	
	67 (19.4)	42.90	29.50	2.46	39.01	27.57	2.70	35.20	25.66	2.97	31.45	23.75	3.25	27.77	21.86	3.55	24.10	19.94	3.87	
	72 (22.2)	46.93	24.09	2.47	42.69	22.40	2.72	38.51	20.71	2.98	34.42	19.04	3.27	30.38	17.37	3.57	26.35	15.68	3.89	
1200 / 0.09	57 (13.8)	39.72	39.72	2.48	36.36	36.36	2.72	33.04	33.04	2.99	29.76	29.76	3.27	26.51	26.51	3.57	23.26	23.26	3.88	
	62 (16.6)	40.35	37.43	2.48	36.71	35.04	2.72	33.12	33.12	2.99	29.77	29.77	3.27	26.52	26.52	3.57	23.26	23.26	3.88	
	63* (17.2)	40.77	30.20	2.48	37.03	28.20	2.72	33.35	26.23	2.99	29.75	24.28	3.27	26.21	22.32	3.57	22.70	20.32	3.88	
	67 (19.4)	43.99	31.47	2.49	39.95	29.42	2.74	36.00	27.40	3.00	32.13	25.39	3.28	28.31	23.39	3.58	24.52	21.34	3.90	
	72 (22.2)	48.09	25.31	2.51	43.69	23.54	2.75	39.37	21.78	3.02	35.13	20.04	3.30	30.95	18.29	3.60	26.79	16.52	3.92	
1350 / 0.10	57 (13.8)	41.20	41.20	2.51	37.67	37.67	2.76	34.19	34.19	3.02	30.76	30.76	3.30	27.36	27.36	3.60	23.95	23.95	3.92	
	62 (16.6)	41.37	39.65	2.51	37.69	37.69	2.76	34.19	34.19	3.02	30.76	30.76	3.30	27.36	27.36	3.60	23.95	23.95	3.92	
	63* (17.2)	41.60	31.96	2.51	37.74	29.86	2.76	33.95	27.79	3.02	30.25	25.74	3.30	26.62	23.66	3.60	23.02	21.54	3.91	
	67 (19.4)	44.85	33.35	2.52	40.70	31.21	2.77	36.63	29.08	3.03	32.65	26.97	3.31	28.73	24.84	3.61	24.84	22.67	3.93	
	72 (22.2)	49.01	26.47	2.54	44.48	24.63	2.78	40.03	22.80	3.05	35.68	20.98	3.33	31.39	19.16	3.63	27.12	17.31	3.95	

*At 75°F (23.9 °C) entering dry bulb—Tennessee Valley Authority [TVA] rating conditions; all others at 80°F (26.7 °C) entering dry bulb. See Legend and Notes.

PHD436 HEATING EXTENDED PERFORMANCE TABLE																									
INDOOR AIR			OUTDOOR COIL ENTERING AIR TEMPERATURES °F (°C)																						
			-10 (-23.3)			0 (-17.8)			10 (-12.2)			20 (-6.7)			30 (-1.1)			40 (4.4)			50 (10)			60 (15.6)	
EDB	CFM	Capacity MBtuh		Total Sys KW	Capacity MBtuh		Total Sys KW	Capacity MBtuh		Total Sys KW	Capacity MBtuh		Total Sys KW	Capacity MBtuh		Total Sys KW	Capacity MBtuh		Total Sys KW	Capacity MBtuh		Total Sys KW	Capacity MBtuh		Total Sys KW
		Total	Integ		Total	Integ		Total	Integ		Total	Integ		Total	Integ		Total	Integ		Total	Integ		Total	Integ	
65	1050	11.29	10.39	2.23	14.77	13.59	2.33	18.36	16.85	2.42	22.15	20.09	2.51	26.29	23.04	2.61	31.12	31.12	2.74	36.45	36.45	2.89	43.29	43.29	3.09
	1200	11.49	10.57	2.25	14.97	13.78	2.33	18.58	17.05	2.41	22.39	20.30	2.48	26.60	23.31	2.57	31.43	31.43	2.68	37.07	37.07	2.82	43.51	43.51	2.98
	1350	11.66	10.72	2.26	15.15	13.94	2.34	18.77	17.23	2.40	22.59	20.49	2.47	26.87	23.54	2.55	31.76	31.76	2.64	37.79	37.79	2.77	42.96	42.96	2.92
70	1050	10.75	9.89	2.33	14.33	13.18	2.43	17.99	16.51	2.53	21.82	19.79	2.64	25.90	22.70	2.74	30.63	30.63	2.88	35.89	35.89	3.03	42.54	42.54	3.25
	1200	10.95	10.08	2.34	14.54	13.38	2.43	18.22	16.72	2.52	22.06	20.01	2.61	26.21	22.96	2.70	31.01	31.01	2.82	36.42	36.42	2.96	43.07	43.07	3.13
	1350	11.13	10.24	2.35	14.72	13.55	2.44	18.41	16.90	2.52	22.27	20.20	2.60	26.47	23.19	2.68	31.48	31.48	2.78	37.12	37.12	2.91	42.78	42.78	3.06
75	1050	10.16	9.34	2.42	13.83	12.73	2.54	17.57	16.13	2.65	21.46	19.46	2.76	25.55	22.39	2.88	30.22	30.22	3.02	35.36	35.36	3.18	41.76	41.76	3.40
	1200	10.36	9.53	2.43	14.06	12.94	2.54	17.81	16.35	2.64	21.71	19.69	2.74	25.83	22.63	2.84	30.58	30.58	2.96	35.87	35.87	3.10	42.56	42.56	3.29
	1350	10.53	9.69	2.45	14.25	13.11	2.55	18.01	16.53	2.64	21.92	19.88	2.72	26.07	22.84	2.81	30.89	30.89	2.92	36.37	36.37	3.05	42.48	42.48	3.21

See Legend and Notes following tables.

PHD442 COOLING EXTENDED PERFORMANCE TABLE

EVAPORATOR AIR		CONDENSER ENTERING AIR TEMPERATURES °F (°C)																				
		75 (23.9)			85 (29.4)			95 (35)			105 (40.6)			115 (46.1)			125 (51.7)					
		Capacity MBtuh		Total Sys KW	Capacity MBtuh		Total Sys KW	Capacity MBtuh		Total Sys KW	Capacity MBtuh		Total Sys KW	Capacity MBtuh		Total Sys KW	Capacity MBtuh		Total Sys KW			
CFM / BF	EWB °F (°C)	Total	Sens	Total	Sens	Total	Sens	Total	Sens	Total	Sens	Total	Sens	Total	Sens	Total	Sens	Total	Sens	Total	Sens	
1225 / 0.19	57 (13.8)	39.54	39.54	2.66	37.86	37.86	2.97	36.04	36.04	3.31	34.09	34.09	3.68	33.27	33.27	3.64	29.41	29.41	4.50			
	62 (16.6)	41.07	37.14	2.68	39.05	35.92	2.99	36.93	34.59	3.32	34.67	33.19	3.69	33.74	32.57	3.64	29.46	29.46	4.50			
	63* (17.2)	41.31	30.04	2.68	39.26	28.92	2.99	37.09	27.73	3.32	34.77	26.46	3.69	33.77	25.92	3.64	29.35	23.46	4.50			
	67 (19.4)	44.64	31.32	2.72	42.44	30.19	3.03	40.10	28.99	3.36	37.58	27.69	3.73	36.64	27.22	3.69	31.64	24.59	4.54			
1400 / 0.21	72 (22.2)	48.47	25.70	2.76	46.05	24.64	3.07	43.49	23.53	3.41	40.72	22.32	3.77	39.79	21.91	3.74	34.12	19.42	4.59			
	57 (13.8)	41.22	41.22	2.72	39.41	39.41	3.03	37.47	37.47	3.37	35.37	35.37	3.74	34.56	34.56	3.70	30.33	30.33	4.56			
	62 (16.6)	42.17	39.64	2.73	40.08	38.31	3.04	37.89	36.85	3.38	35.52	35.52	3.74	34.66	34.66	3.70	30.34	30.34	4.56			
	63* (17.2)	42.36	31.75	2.74	40.21	30.57	3.04	37.94	29.32	3.37	35.51	27.98	3.74	34.52	27.44	3.70	29.83	24.80	4.55			
1575 / 0.23	67 (19.4)	45.76	33.17	2.78	43.45	31.97	3.08	41.00	30.70	3.42	38.36	29.32	3.78	37.43	28.87	3.75	32.13	26.08	4.59			
	72 (22.2)	49.65	26.83	2.82	47.11	25.72	3.13	44.43	24.56	3.46	41.52	23.28	3.83	40.63	22.89	3.80	34.63	20.24	4.64			
	57 (13.8)	42.65	42.65	2.78	40.73	40.73	3.09	38.67	38.67	3.43	36.45	36.45	3.80	35.65	35.65	3.76	31.08	31.08	4.62			
	62 (16.6)	43.14	41.90	2.79	40.94	40.94	3.09	38.75	38.75	3.43	36.45	36.45	3.80	35.65	35.65	3.76	31.08	31.08	4.62			
1575 / 0.23	63* (17.2)	43.20	33.36	2.79	40.97	32.13	3.09	38.61	30.82	3.42	36.08	29.41	3.79	35.10	28.88	3.75	30.20	26.10	4.60			
	67 (19.4)	46.66	34.92	2.83	44.26	33.67	3.13	41.71	32.33	3.47	38.97	30.89	3.83	38.06	30.44	3.80	32.50	27.49	4.64			
	72 (22.2)	50.59	27.89	2.87	47.95	26.72	3.18	45.17	25.51	3.51	42.14	24.18	3.88	41.29	23.80	3.86	35.01	21.00	4.69			

*At 75°F (23.9 °C) entering dry bulb—Tennessee Valley Authority [TVA] rating conditions; all others at 80°F (26.7 °C) entering dry bulb. See Legend and Notes.

PHD442 HEATING EXTENDED PERFORMANCE TABLE

INDOOR AIR		OUTDOOR COIL ENTERING AIR TEMPERATURES °F (°C)																															
		-10 (-23.3)				0 (-17.8)				10 (-12.2)				20 (-6.7)				30 (-1.1)				40 (4.4)				50 (10)				60 (15.6)			
		Capacity MBtuh		Total Sys KW	Capacity MBtuh		Total Sys KW	Capacity MBtuh		Total Sys KW	Capacity MBtuh		Total Sys KW	Capacity MBtuh		Total Sys KW	Capacity MBtuh		Total Sys KW	Capacity MBtuh		Total Sys KW	Capacity MBtuh		Total Sys KW	Capacity MBtuh		Total Sys KW					
EDB	CFM	Total	Integ	Total	Integ	Total	Integ	Total	Integ	Total	Integ	Total	Integ	Total	Integ	Total	Integ	Total	Integ	Total	Integ	Total	Integ	Total	Integ	Total	Integ						
65	1225	13.75	12.65	2.45	17.57	16.17	2.56	21.58	19.81	2.68	25.83	23.43	2.81	30.61	26.82	2.96	36.10	36.10	3.14	42.45	42.45	3.36	50.07	50.07	3.66								
	1400	13.97	12.85	2.47	17.81	16.38	2.57	21.83	20.04	2.68	26.10	23.67	2.79	30.97	27.13	2.92	36.56	36.56	3.08	43.06	43.06	3.29	50.69	50.69	3.55								
	1575	14.17	13.03	2.49	18.01	16.57	2.58	22.05	20.23	2.68	26.32	23.87	2.78	31.28	27.40	2.90	36.94	36.94	3.05	43.53	43.53	3.26	50.61	50.61	3.51								
70	1225	13.24	12.18	2.57	17.15	15.78	2.70	21.21	19.47	2.82	25.49	23.12	2.96	30.16	26.42	3.11	35.59	35.59	3.30	41.83	41.83	3.53	49.28	49.28	3.84								
	1400	13.47	12.39	2.59	17.39	16.00	2.70	21.46	19.70	2.82	25.76	23.37	2.94	30.51	26.74	3.07	36.03	36.03	3.24	42.41	42.41	3.45	50.08	50.08	3.72								
	1575	13.67	12.57	2.61	17.60	16.19	2.72	21.68	19.90	2.82	26.00	23.58	2.93	30.82	27.00	3.05	36.40	36.40	3.21	42.88	42.88	3.41	50.18	50.18	3.67								
75	1225	12.69	11.67	2.69	16.68	15.35	2.83	20.80	19.09	2.97	25.13	22.79	3.12	29.77	26.08	3.28	35.10	35.10	3.47	41.22	41.22	3.71	48.53	48.53	4.02								
	1400	12.91	11.88	2.71	16.93	15.57	2.84	21.07	19.34	2.96	25.41	23.04	3.09	30.09	26.37	3.24	35.53	35.53	3.41	41.79	41.79	3.63	49.30	49.30	3.91								
	1575	13.12	12.07	2.74	17.14	15.77	2.85	21.29	19.54	2.97	25.65	23.26	3.08	30.37	26.61	3.21	35.88	35.88	3.37	42.24	42.24	3.58	49.68	49.68	3.84								

See Legend and Notes following tables.

PHD448 COOLING EXTENDED PERFORMANCE TABLE																			
EVAPORATOR AIR		CONDENSER ENTERING AIR TEMPERATURES °F (°C)																	
		75 (23.9)			85 (29.4)			95 (35)			105 (40.6)			115 (46.1)			125 (51.7)		
		Capacity MBtuh		Total Sys KW	Capacity MBtuh		Total Sys KW	Capacity MBtuh		Total Sys KW	Capacity MBtuh		Total Sys KW	Capacity MBtuh		Total Sys KW	Capacity MBtuh		Total Sys KW
CFM / BF	EWB °F (°C)	Total	Sens	Total	Sens	Total	Sens	Total	Sens	Total	Sens	Total	Sens	Total	Sens	Total	Sens	Total	Sens
1400 / 0.09	57 (13.8)	48.07	48.07	2.99	44.60	44.60	3.35	41.11	41.11	3.74	37.59	37.59	4.18	33.97	33.97	4.66	30.20	30.20	5.18
	62 (16.6)	49.24	42.95	3.00	45.38	40.81	3.35	41.54	38.58	3.75	37.68	37.68	4.18	33.97	33.97	4.66	30.20	30.20	5.18
	63* (17.2)	49.85	34.74	3.00	45.89	32.91	3.35	41.92	31.03	3.75	37.95	29.14	4.18	33.92	27.18	4.66	29.77	25.09	5.17
	67 (19.4)	53.72	36.13	3.02	49.45	34.25	3.38	45.16	32.34	3.77	40.85	30.39	4.21	36.48	28.37	4.68	31.96	26.23	5.20
	72 (22.2)	58.70	29.21	3.05	54.00	27.52	3.41	49.26	25.79	3.80	44.53	24.03	4.24	39.71	22.21	4.72	34.74	20.27	5.23
1600 / 0.10	57 (13.8)	50.08	50.08	3.05	46.40	46.40	3.41	42.70	42.70	3.81	38.95	38.95	4.25	35.11	35.11	4.72	31.11	31.11	5.24
	62 (16.6)	50.54	45.92	3.06	46.59	43.48	3.41	42.71	42.71	3.81	38.95	38.95	4.25	35.11	35.11	4.72	31.11	31.11	5.24
	63* (17.2)	50.98	36.96	3.06	46.86	35.03	3.41	42.75	33.06	3.81	38.62	31.05	4.24	34.44	28.96	4.72	30.16	26.75	5.23
	67 (19.4)	54.90	38.50	3.08	50.46	36.52	3.44	46.00	34.50	3.83	41.53	32.45	4.27	37.00	30.30	4.74	32.34	28.01	5.26
	72 (22.2)	59.95	30.65	3.11	55.05	28.88	3.47	50.14	27.08	3.86	45.24	25.24	4.30	40.25	23.33	4.77	35.12	21.31	5.28
1800 / 0.11	57 (13.8)	51.77	51.77	3.11	47.91	47.91	3.47	44.01	44.01	3.87	40.06	40.06	4.31	36.03	36.03	4.79	31.82	31.82	5.30
	62 (16.6)	51.79	51.79	3.11	47.91	47.91	3.47	44.02	44.02	3.87	40.06	40.06	4.31	36.03	36.03	4.79	31.82	31.82	5.30
	63* (17.2)	51.85	39.08	3.11	47.61	37.05	3.47	43.38	34.99	3.87	39.13	32.86	4.30	34.84	30.64	4.78	30.46	28.24	5.29
	67 (19.4)	55.81	40.79	3.14	51.24	38.71	3.50	46.63	36.58	3.89	42.04	34.40	4.33	37.39	32.12	4.80	32.61	29.67	5.31
	72 (22.2)	60.91	32.02	3.17	55.86	30.17	3.53	50.80	28.29	3.92	45.76	26.38	4.36	40.65	24.40	4.83	35.38	22.30	5.34

*At 75°F (23.9 °C) entering dry bulb—Tennessee Valley Authority [TVA] rating conditions; all others at 80°F (26.7 °C) entering dry bulb. See Legend and Notes.

PHD448 HEATING EXTENDED PERFORMANCE TABLE																										
INDOOR AIR			OUTDOOR COIL ENTERING AIR TEMPERATURES °F (°C)																							
			-10 (-23.3)			0 (-17.8)			10 (-12.2)			20 (-6.7)			30 (-1.1)			40 (4.4)			50 (10)			60 (15.6)		
			Capacity MBtuh		Total Sys KW	Capacity MBtuh		Total Sys KW	Capacity MBtuh		Total Sys KW	Capacity MBtuh		Total Sys KW	Capacity MBtuh		Total Sys KW	Capacity MBtuh		Total Sys KW	Capacity MBtuh		Total Sys KW	Capacity MBtuh		Total Sys KW
EDB	CFM	Total	Integ	Total	Integ	Total	Integ	Total	Integ	Total	Integ	Total	Integ	Total	Integ	Total	Integ	Total	Integ	Total	Integ	Total	Integ	Total	Integ	
65	1400	15.21	14.00	3.19	19.74	18.16	3.29	24.43	22.43	3.40	29.38	26.64	3.51	34.68	30.38	3.63	40.60	40.60	3.78	47.66	47.66	3.97	55.91	55.91	4.22	
	1600	15.51	14.27	3.22	20.06	18.45	3.31	24.77	22.74	3.40	29.73	26.97	3.50	35.08	30.74	3.61	41.18	41.18	3.74	48.35	48.35	3.90	57.32	57.32	4.12	
	1800	15.79	14.52	3.26	20.34	18.71	3.35	25.07	23.01	3.42	30.04	27.25	3.51	35.44	31.05	3.60	41.70	41.70	3.72	48.93	48.93	3.87	57.75	57.75	4.06	
70	1400	14.51	13.35	3.32	19.15	17.62	3.44	23.92	21.96	3.56	28.91	26.22	3.68	34.20	29.97	3.81	39.99	39.99	3.97	46.96	46.96	4.17	55.04	55.04	4.42	
	1600	14.81	13.63	3.36	19.47	17.92	3.46	24.26	22.27	3.57	29.28	26.55	3.67	34.61	30.33	3.79	40.53	40.53	3.92	47.63	47.63	4.09	56.25	56.25	4.32	
	1800	15.09	13.88	3.40	19.76	18.18	3.50	24.57	22.55	3.59	29.60	26.84	3.68	34.97	30.64	3.78	40.99	40.99	3.90	48.19	48.19	4.06	57.10	57.10	4.25	
75	1400	13.74	12.64	3.46	18.50	17.02	3.59	23.36	21.44	3.72	28.41	25.77	3.86	33.71	29.54	4.00	39.42	39.42	4.16	46.29	46.29	4.37	54.20	54.20	4.63	
	1600	14.04	12.92	3.49	18.83	17.32	3.62	23.71	21.77	3.73	28.79	26.11	3.85	34.13	29.90	3.97	39.91	39.91	4.11	46.93	46.93	4.29	55.09	55.09	4.52	
	1800	14.32	13.17	3.54	19.12	17.59	3.65	24.02	22.05	3.75	29.12	26.41	3.85	34.49	30.22	3.96	40.36	40.36	4.08	47.48	47.48	4.25	56.24	56.24	4.46	

See Legend and Notes following tables.

PHD460 COOLING EXTENDED PERFORMANCE TABLE																			
EVAPORATOR AIR		CONDENSER ENTERING AIR TEMPERATURES °F (°C)																	
		75 (23.9)			85 (29.4)			95 (35)			105 (40.6)			115 (46.1)			125 (51.7)		
CFM / BF	EWB °F (°C)	Capacity MBtuh		Total Sys KW	Capacity MBtuh		Total Sys KW	Capacity MBtuh		Total Sys KW	Capacity MBtuh		Total Sys KW	Capacity MBtuh		Total Sys KW	Capacity MBtuh		Total Sys KW
		Total	Sens		Total	Sens		Total	Sens		Total	Sens		Total	Sens		Total	Sens	
1750 / 0.07	57(13.8)	63.53	63.53	3.78	58.78	58.78	4.29	53.97	53.97	4.86	49.09	49.09	5.49	44.01	44.01	6.19	42.42	42.42	6.41
	62(16.6)	65.04	51.03	3.79	59.74	50.40	4.30	54.44	49.51	4.86	49.15	49.15	5.50	44.01	44.01	6.19	38.66	38.66	6.95
	63*(17.2)	65.92	41.28	3.80	60.47	40.65	4.31	54.99	39.84	4.87	49.48	38.85	5.50	43.83	37.60	6.19	42.07	38.16	6.40
	67(19.4)	70.86	42.85	3.85	64.96	42.22	4.35	59.00	41.40	4.92	52.98	40.40	5.54	46.84	39.11	6.23	40.50	37.40	6.98
2000 / 0.08	72(22.2)	77.33	34.48	3.90	70.80	33.73	4.41	64.19	32.79	4.98	57.55	31.67	5.60	50.77	30.29	6.29	43.78	28.58	7.03
	57(13.8)	66.05	66.05	3.88	61.00	61.00	4.40	55.88	55.88	4.97	50.65	50.65	5.60	45.26	45.26	6.30	39.58	39.58	7.06
	62(16.6)	66.61	54.49	3.89	61.13	61.13	4.40	55.88	55.88	4.97	50.66	50.66	5.60	45.25	45.25	6.30	39.57	39.57	7.06
	63*(17.2)	67.26	43.89	3.89	61.59	43.24	4.40	55.88	42.41	4.97	50.16	41.35	5.59	44.32	39.99	6.29	38.33	38.21	7.04
2250 / 0.09	67(19.4)	72.23	45.64	3.94	66.09	45.00	4.45	59.87	44.14	5.01	53.63	43.07	5.64	47.29	41.70	6.33	40.75	39.91	7.08
	72(22.2)	78.76	36.15	4.00	71.95	35.36	4.51	65.10	34.38	5.07	58.23	33.22	5.70	51.25	31.78	6.38	44.04	29.99	7.12
	57(13.8)	68.16	68.16	3.98	62.83	62.83	4.50	57.41	57.41	5.07	51.90	51.90	5.70	46.22	46.22	6.40	40.27	40.27	7.16
	62(16.6)	68.17	68.17	3.98	62.83	62.83	4.50	57.41	57.41	5.07	51.90	51.90	5.71	46.22	46.22	6.40	40.27	40.27	7.16
2250 / 0.09	63*(17.2)	68.27	46.41	3.98	62.41	45.72	4.49	56.54	44.84	5.06	50.64	43.71	5.69	44.66	42.24	6.38	38.53	40.25	7.13
	67(19.4)	73.27	48.35	4.03	66.92	47.68	4.54	60.50	46.77	5.10	54.10	45.64	5.73	47.60	44.16	6.42	40.92	42.14	7.17
	72(22.2)	79.84	37.74	4.09	72.79	36.91	4.60	65.73	35.91	5.16	58.70	34.70	5.79	51.53	33.23	6.48	44.15	31.39	7.22

*At 75°F (23.9 °C) entering dry bulb—Tennessee Valley Authority [TVA] rating conditions; all others at 80°F (26.7 °C) entering dry bulb. See Legend and Notes.

PHD460 HEATING EXTENDED PERFORMANCE TABLE																									
INDOOR AIR		OUTDOOR COIL ENTERING AIR TEMPERATURES °F (°C)																							
		-10 (-23.3)			0 (-17.8)			10 (-12.2)			20 (-6.7)			30 (-1.1)			40 (4.4)		50 (10)		60 (15.6)				
EDB	CFM	Capacity MBtuh		Total Sys KW	Capacity MBtuh		Total Sys KW	Capacity MBtuh		Total Sys KW	Capacity MBtuh		Total Sys KW	Capacity MBtuh		Total Sys KW	Capacity MBtuh		Total Sys KW	Capacity MBtuh		Total Sys KW	Capacity MBtuh		Total Sys KW
		Total	Integ		Total	Integ		Total	Integ		Total	Integ		Total	Integ		Total	Integ		Total	Integ		Total	Integ	
65	1750	21.44	19.72	3.85	27.02	24.86	3.97	32.88	30.18	4.09	39.13	35.49	4.23	46.15	40.44	4.40	54.26	54.26	4.61	63.98	63.98	4.86	74.82	74.82	5.16
	2000	21.85	20.11	3.90	27.45	25.26	4.01	33.33	30.60	4.12	39.63	35.94	4.24	46.77	40.98	4.38	55.02	55.02	4.56	65.19	65.19	4.78	74.99	74.99	5.04
	2250	22.24	20.46	3.97	27.85	25.63	4.06	33.75	30.98	4.15	40.07	36.34	4.26	47.32	41.46	4.39	56.12	56.12	4.56	65.29	65.29	4.75	73.80	73.80	4.99
70	1750	20.75	19.09	4.03	26.44	24.33	4.16	32.38	29.72	4.30	38.64	35.04	4.45	45.62	39.97	4.62	53.55	53.55	4.84	62.76	62.76	5.10	73.96	73.96	5.41
	2000	21.17	19.48	4.09	26.88	24.73	4.20	32.84	30.14	4.32	39.14	35.50	4.45	46.18	40.46	4.60	54.29	54.29	4.79	64.31	64.31	5.02	74.39	74.39	5.29
	2250	21.56	19.84	4.15	27.28	25.11	4.25	33.25	30.52	4.36	39.59	35.91	4.47	46.68	40.90	4.61	54.93	54.93	4.78	64.77	64.77	4.98	73.71	73.71	5.23
75	1750	20.00	18.40	4.22	25.80	23.74	4.36	31.83	29.21	4.51	38.15	34.60	4.68	45.07	39.49	4.86	52.71	52.71	5.07	61.83	61.83	5.35	73.09	73.09	5.68
	2000	20.42	18.79	4.28	26.26	24.16	4.40	32.30	29.64	4.53	38.62	35.03	4.67	45.64	39.99	4.83	53.58	53.58	5.03	63.19	63.19	5.27	73.64	73.64	5.54
	2250	20.82	19.15	4.34	26.67	24.54	4.46	32.73	30.04	4.57	39.07	35.43	4.69	46.14	40.43	4.84	54.20	54.20	5.01	64.17	64.17	5.22	73.39	73.39	5.47

- LEGEND**
- BF — Bypass Factor
 - edb — Entering Dry—Bulb
 - Ewb — Entering Wet—Bulb
 - kW — Total Unit Power Input
 - SHC — Sensible Heat Capacity (1000 Btuh)
 - TC — Total Capacity (1000 Btuh) (net)
 - rh — Relative Humidity

- COOLING NOTES:**
- Ratings are net; they account for the effects of the evaporator—fan motor power and heat.
 - Direct interpolation is permissible. Do not extrapolate.
 - The following formulas may be used:

$$t_{ldb} = t_{edb} - \frac{\text{Sensible capacity (Btuh)}}{1.10 \times \text{cfm}}$$

$$t_{lwb} = \text{Wet—bulb temperature corresponding to enthalpy air leaving evaporator coil (} h_{lwb} \text{)}$$

$$h_{lwb} = h_{ewb} - \frac{\text{total capacity (Btuh)}}{4.5 \times \text{cfm}}$$
 Where: h_{ewb} = Enthalpy of air entering evaporator coil
 - The SHC is based on 80°F (26.7 °C) edb temperature of air entering evaporator coil. Below 80°F (26.7 °C) edb, subtract (corr factor x cfm) from SHC. Above 80°F (26.7 °C) edb, add (corr factor x cfm) to SHC.
Correction Factor = $1.10 \times (1 + BF) \times (edb + 80)$.
 - Integrated capacity is maximum (instantaneous) capacity less the effect of frost on the outdoor coil and the heat required to defrost it.

UNIT DIMENSIONS - PHD424-30

UNIT	SERIES	ELECTRICAL CHARACTERISTICS	UNIT WT.		UNIT HEIGHT IN/MM			CENTER OF GRAVITY IN/MM				
			LB	KG	"A"	"X"	"Y"	"Z"				
24	1	208/230-1	348	158	44-1/8	1121	20-1/2	521	15-1/2	394	16-1/2	419
30	1	208/230-1, 208/230-3-40	340	154	44-1/8	1121	20-1/2	521	15-1/2	394	16-1/2	419

UNITS	VOLTAGE	CORNER WEIGHT LB/KG			
		"1"	"2"	"3"	"4"
24	208/230	93	42	73	33
30	208/230	90	41	71	32

NOTE: ALL TABLE DATA RELEVANT FOR ALL FACTORY INSTALLED OPTIONS EXCEPT ECONOMIZER

REQUIRED CLEARANCES TO CONSTRUCTIBLE UNITS

	INCHES [MM]
TOP OF UNIT	14 [355.6]
DUCT SIDE OF UNIT	2 [50.8]
SIDE OPPOSITE DUCTS	14 [355.6]
DUCT OPPOSITE DUCTS	8 [203.2]
ELECTRICAL PANEL	36 [914.4]

NEC REQUIRED CLEARANCES

	INCHES [MM]
BETWEEN UNITS, POWER ENTRY SIDE	36 [914.4]
UNIT AND UNSURROUNDED SURFACES, POWER ENTRY SIDE	36 [914.4]
UNIT AND BLOCK OR CONCRETE WALLS AND OTHER GROUNDED SURFACES, POWER ENTRY SIDE	42 [1066.8]

REQUIRED CLEARANCE FOR OPERATION AND SERVICING

	INCHES [MM]
EVAP. COIL ACCESS SIDE	36 [914.0]
POWER ENTRY SIDE	42 [1066.8]
(EXCEPT FOR NEC REQUIREMENTS)	48 [1219.2]
DUCT OPPOSITE DUCTS	36 [914.0]
SIDE OPPOSITE DUCTS	36 [914.0]
DUCT PANEL	42 [1066.8]

*MINIMUM DISTANCES IF UNIT IS PLACED LESS THAN 12" (304.8) FROM WALL SYSTEM, THEN SYSTEM PERFORMANCE MAYBE COMPROMISED.

DIMENSIONS IN [] ARE IN MILLIMETERS

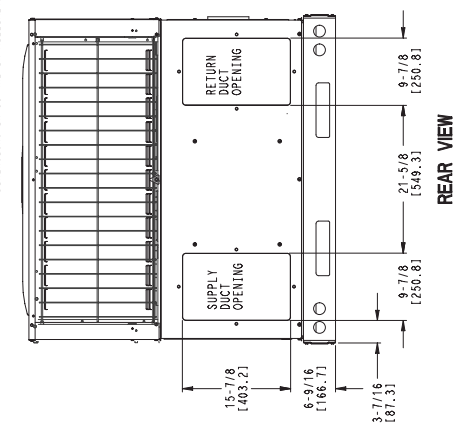
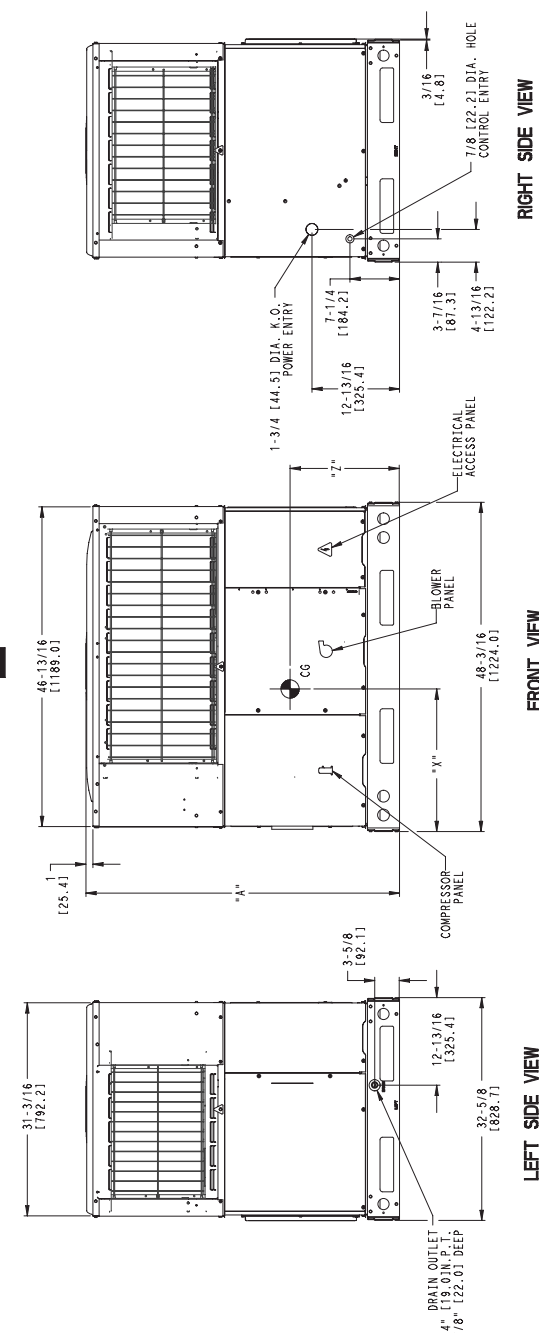
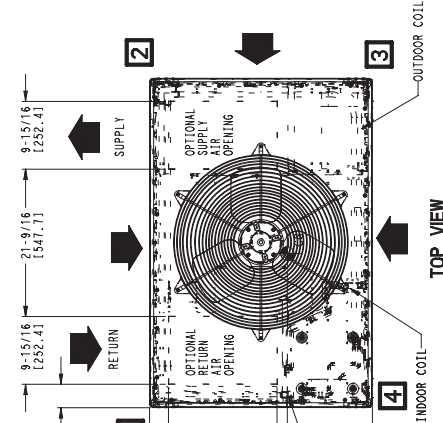

REV 2.0
50VT500201

UNIT	SERIES	ELECTRICAL CHARACTERISTICS	UNIT WT.		UNIT HEIGHT IN/MM				CENTER OF GRAVITY IN/MM			
			LB	KG	"A"	"B"	"C"	"D"	X	Y	Z	
36	208/230-1, 208/230-3-60	418	190	44-3/4	1137	20-1/2	521	17-1/2	445	17-3/8	441	
	460-3-60	432	196	44-3/4	1137	20-1/2	521	17-1/2	445	17-3/8	441	
42	208/230-1, 208/230-3-60	464	210	48-3/4	1238	20-1/2	521	17-1/2	445	17-3/8	448	
	460-3-60	476	216	48-3/4	1238	20-1/2	521	17-1/2	445	17-3/8	448	
48	208/230-1, 208/230-3-60	452	205	48-3/4	1238	20-1/2	521	17-1/2	445	17-3/8	448	
	460-3-60	466	211	48-3/4	1238	20-1/2	521	17-1/2	445	17-3/8	448	
60	208/230-1, 208/230-3-60	506	230	54-3/4	1391	20-1/2	521	17-1/2	445	18	457	
	460-3-60	520	236	54-3/4	1391	20-1/2	521	17-1/2	445	18	457	

UNIT	VOLTAGE	CORNER WEIGHTS LB/KG				"A"			
		"1"	"2"	"3"	"4"				
36	208/230	92	42	73	33	111	50	142	64
	460	96	43	75	34	115	52	146	66
42	208/230	103	47	81	37	124	56	157	71
	460	105	48	83	38	127	57	161	73
48	208/230	100	45	79	36	120	55	153	69
	460	103	47	81	37	124	56	158	72
60	208/230	112	51	88	40	135	61	171	78
	460	113	52	90	41	138	63	176	80

REQUIRED CLEARANCES TO COMBUSTIBLE MATL.

TOP OF UNIT.....14 [355.6]
 DUCT SIDE OF UNIT.....2 [50.8]
 SIDE OPPOSITE DUCTS.....14 [355.6]
 ELECTRICAL PANEL.....6 [152.4]
 ELECTRICAL PANEL.....36 [914.4]

NEC REQUIRED CLEARANCES.

BETWEEN UNITS, POWER ENTRY SIDE.....42 [1066.8]
 BETWEEN UNITS, POWER ENTRY SIDE.....42 [1066.8]
 UNIT AND GROUND SURFACE, POWER ENTRY SIDE.....36 [914.4]
 UNIT AND BLOCK OR CONCRETE WALLS AND OTHER GROUND SURFACES, POWER ENTRY SIDE.....42 [1066.8]

REQUIRED CLEARANCE FOR OPERATION AND SERVICING

EVAP. COIL ACCESS SIDE.....36 [914.4]
 POWER ENTRY SIDE.....42 [1066.8]
 (EXCEPT FOR NEC REQUIREMENTS)
 UNIT TOP.....48 [1219.2]
 SIDE OPPOSITE DUCTS.....36 [914.4]
 DUCT PANEL.....12 [304.8]

*MINIMUM DISTANCES: IF UNIT IS PLACED LESS THAN 12 [304.8] FROM WALL SYSTEM, THEN SYSTEM PERFORMANCE MAYBE COMPROMISED.

DIMENSIONS IN [] ARE IN MM

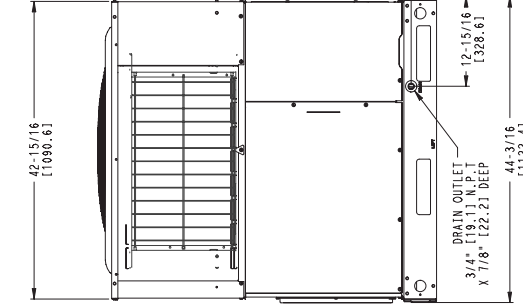
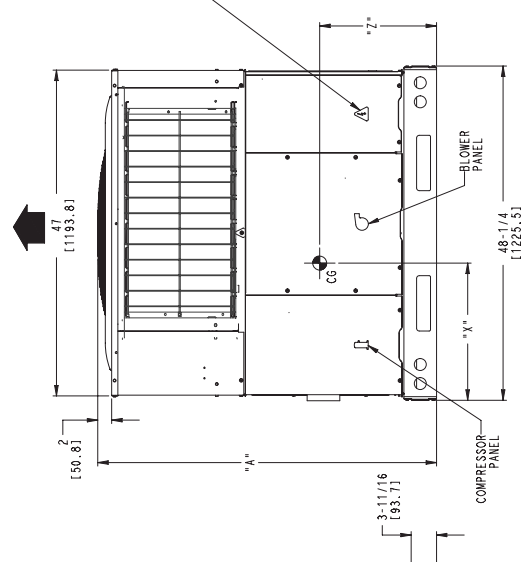
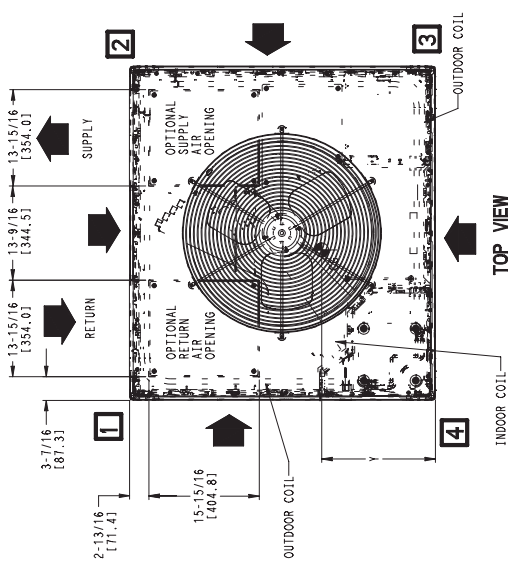

50VT500202
 REV 2.0

CONNECTION WIRING DIAGRAM

DANGER: ELECTRICAL SHOCK HAZARD DISCONNECT POWER BEFORE SERVICING

**SCHEMATIC
208/230-1-60**

NOTES:

1. IF ANY OF THE ORIGINAL WIRES FURNISHED ARE REPLACED, THEY MUST BE REPLACED WITH THE SAME WIRE OR ITS EQUIVALENT.
2. SEE PRICE PAGES FOR THERMOSTATS.
3. USE 75 DEG. COPPER CONDUCTORS FOR FIELD INSTALLATION.
4. SEE INSTALLATION INSTRUCTIONS FOR PROPER HEATING AND COOLING CONNECTIONS FOR YOUR UNIT. INDOOR FAN MOTOR PLUGS - "DO NOT DISCONNECT UNDER LOAD"
5. CCH NOT USED ON ALL UNITS.
6. THIS FUSE IS MANUFACTURED BY LITTELFUSE, P/N 257003.
7. UNIT FACTORY-SHIPED IN STD MODE.

LEGEND

- △ FIELD SPLICE
- TERMINAL (MARKED)
- TERMINAL (UNMARKED)
- SPLICE
- SPLICE (MARKED)
- FACTORY WIRING
- FIELD POWER WIRING
- FIELD CONTROL WIRING
- ACCESSORY OR OPTIONAL WIRING
- TO INDICATE COMMON POTENTIAL ONLY - NOT TO REPRESENT WIRING

- C CONTACTOR
- CAP 1 CAPACITOR, COMP
- CCH CRANK CASE HEATER
- COMP COMPRESSOR MOTOR
- DB DEFROST BOARD
- DEHUM DEHUMIDIFICATION MODE
- DFT DEFROST TEMPERATURE SWITCH
- DR DEFROST RELAY
- EQUIP EQUIPMENT
- GND GROUND
- HPS HIGH PRESSURE SWITCH
- HR HEATER RELAY
- IFB INDOOR FAN BOARD
- IFM INDOOR FAN MOTOR
- LPS LOW PRESSURE SWITCH
- OFM OUTDOOR FAN MOTOR
- RVS REVERSING VALVE
- STD STANDARD MODE
- TRAN TRANSFORMER
- T-STAT THERMOSTAT

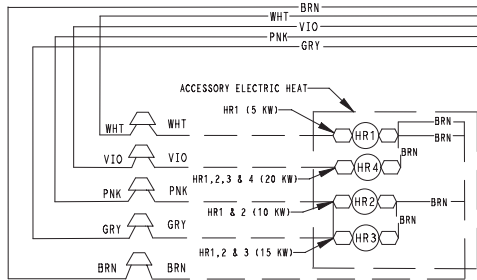
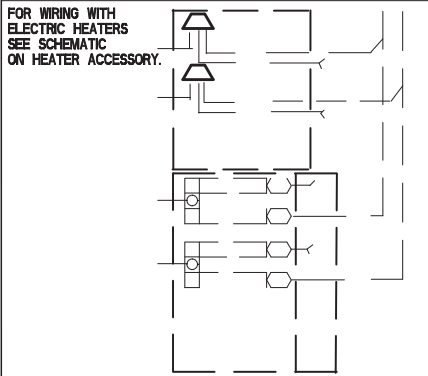
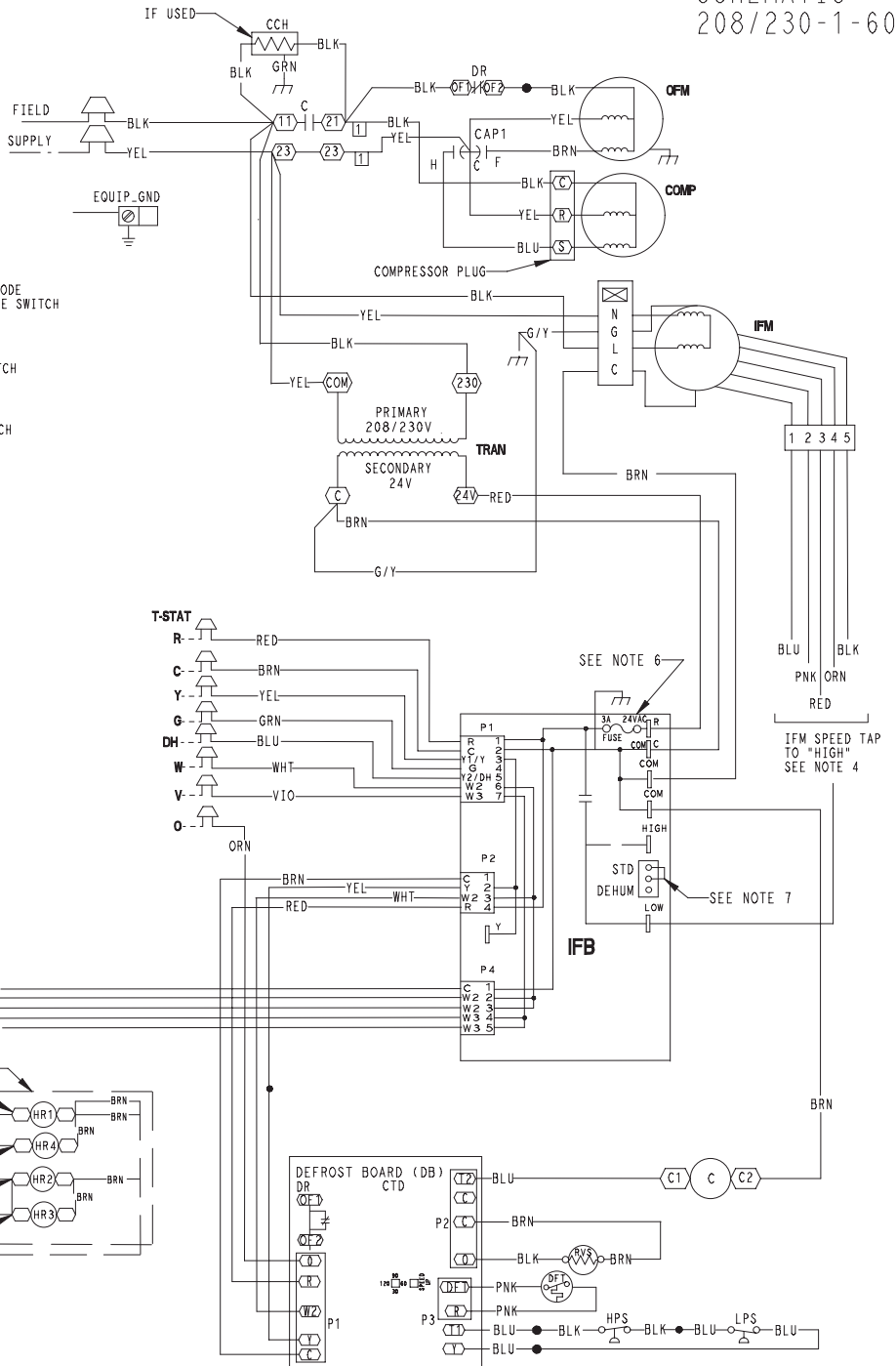

DIP SWITCH SETTINGS

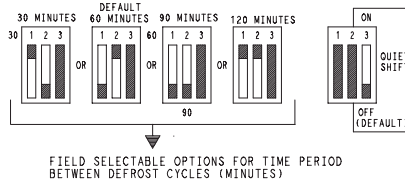

COLOR CODE

- BLK BLACK
- BLU BLUE
- BRN BROWN
- GRY GRAY
- GRN GREEN
- ORN ORANGE
- PNK PINK
- RED RED
- VIO VIOLET
- WHT WHITE
- YEL YELLOW

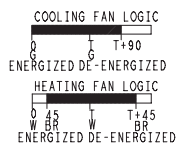

- SPEED UP** **JUMPERED TEST PINS (USE METAL OBJECT) FIELD SPEED-UP CYCLE**
- 1) MOMENTARILY SHORT PINS AND RELEASE TO BYPASS COMPRESSOR OFF DELAY.
 - 2) SHORT FOR 5+ SEC. AND RELEASE FOR FORCED DEFROST.
 - 3) PERMANENT SHORT WILL BE IGNORED.
- DEFROST WILL TERMINATE IN 30 SEC. IF DFT OPEN.
DEFROST WILL TERMINATE NORMALLY IF DFT IS CLOSED.
- THE COMPRESSOR WILL SHUT OFF FOR 30 SEC. ON DEFROST INITIATION AND TERMINATION IN THE "QUIET SHIFT" ON POSITION

LADDER WIRING DIAGRAM

DANGER: ELECTRICAL SHOCK HAZARD DISCONNECT POWER BEFORE SERVICING

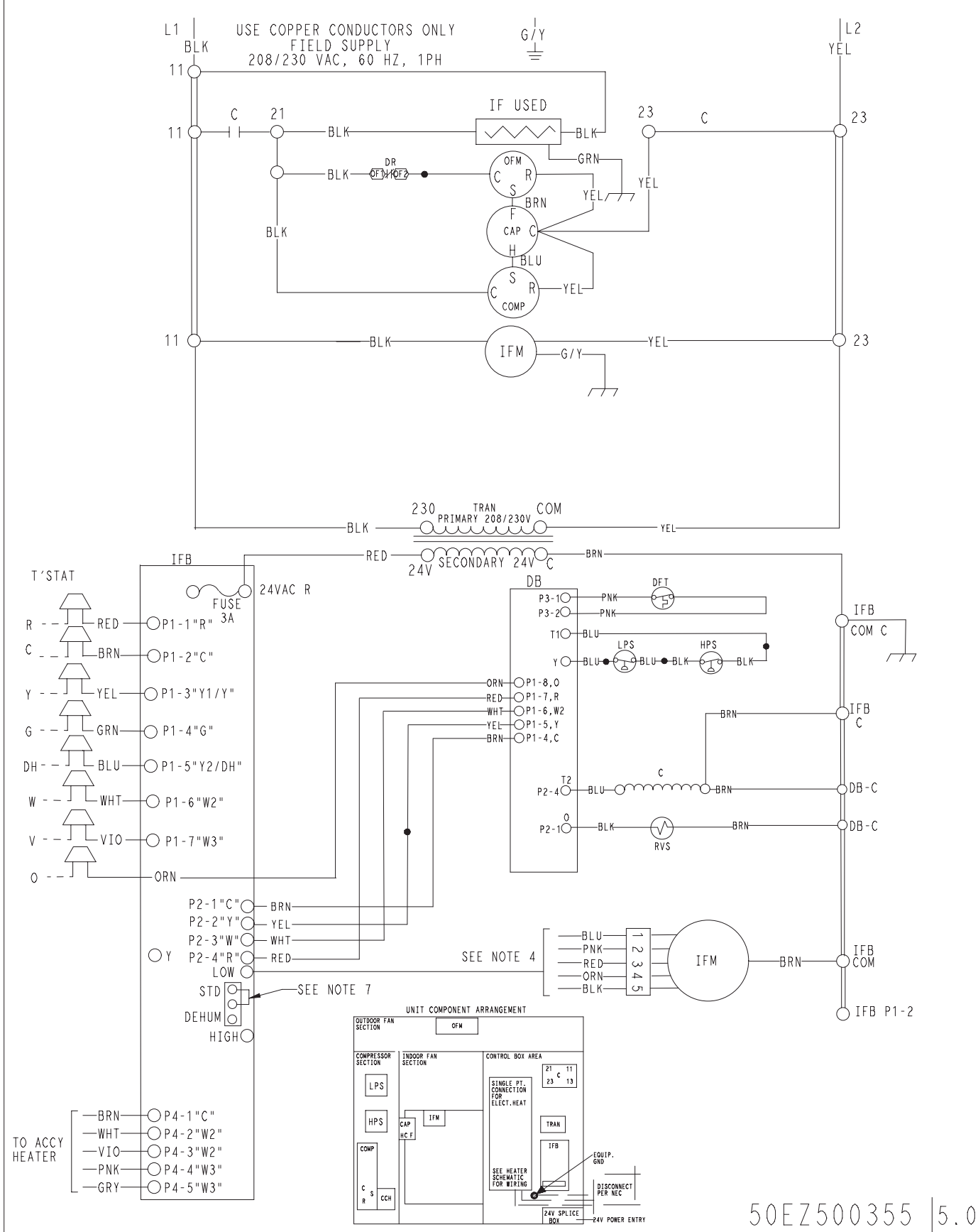

CONTROLS

Operating sequence

When power is supplied to unit, the transformer (TRAN) is energized.

On units with crankcase heater, heater is also energized.

Cooling — With the thermostat in the cooling position, the thermostat makes circuit R-O. This energizes the reversing valve solenoid (RVS) and places the unit in standby condition for cooling.

As the space temperature rises, the thermostat closes circuit R-Y. A circuit is made to contactor (C), starting the compressor (COMP) and outdoor-fan motor (OFM). Circuit R-G is made at the same time and starts the indoor-fan motor (IFM).

When the thermostat is satisfied, contacts open, deenergizing C. The COMP and OFM stop, and the IFM stops after the preselected time delay.

Heating — On a call for heat, thermostat makes circuits R-Y and R-G.

A circuit is made to C, starting COMP and OFM. Circuit R-G also is completed, energizing IFR and starting IFM after the selected time delay.

Should room temperature continue to fall, circuit R-W is made through second-stage thermostat. If optional electric heat package is used, a relay is energized, bringing on first bank of supplemental electric heat. When thermostat is satisfied, contacts open, deenergizing contactor and relay; motors and heaters deenergize.

Defrost — Defrost board (DB) is a time and temperature control, which includes a field-selectable time period (dip switch 1 and 2 on the board) between checks for defrost (30, 60, 90, or 120 minutes). Electronic timer and defrost cycle start only when contactor is energized and defrost thermostat (DFT) is closed.

The defrost board is also equipped with a third dip switch for selecting Quiet Shift operation. The Quiet Shift operation turns compressor off at defrost initiation and termination. Unit is factory shipped with quiet shift turned off.

Defrost mode is identical to cooling mode, except outdoor fan motor stops and a bank of optional electric heat turns on to warm air supplying the conditioned space.

NOTE:

1. Compressor time delay occurs through the defrost control board.
2. Defrost control board has built in 5 minute compressor delay; once the compressor has started and then stopped, it cannot be restarted again until 5 minutes have elapsed.

ACCESSORIES

ROOF CURBS

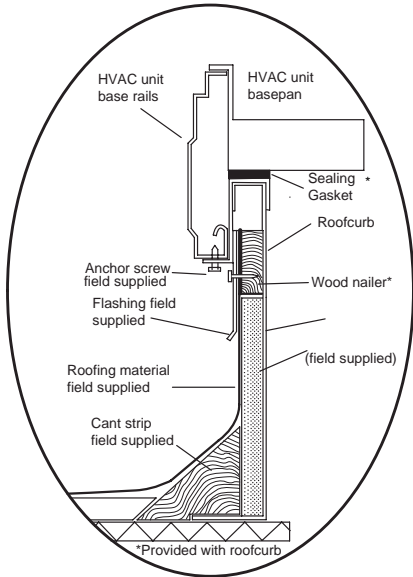

ROOF CURB DETAIL

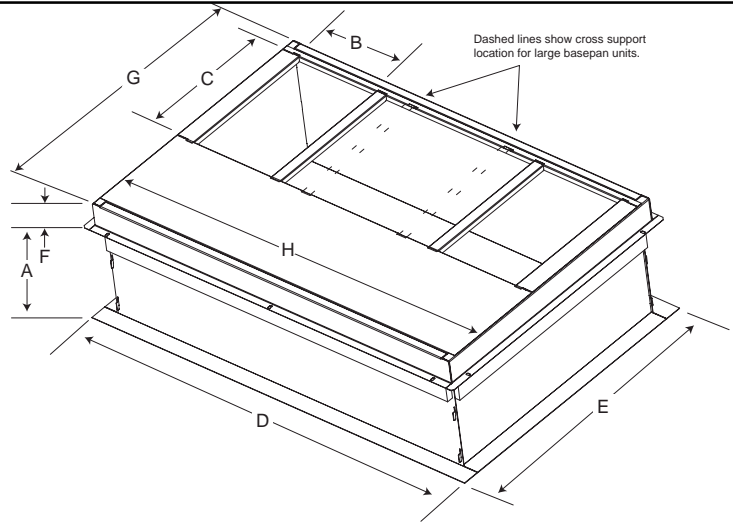

SMALL/COMMON CURB

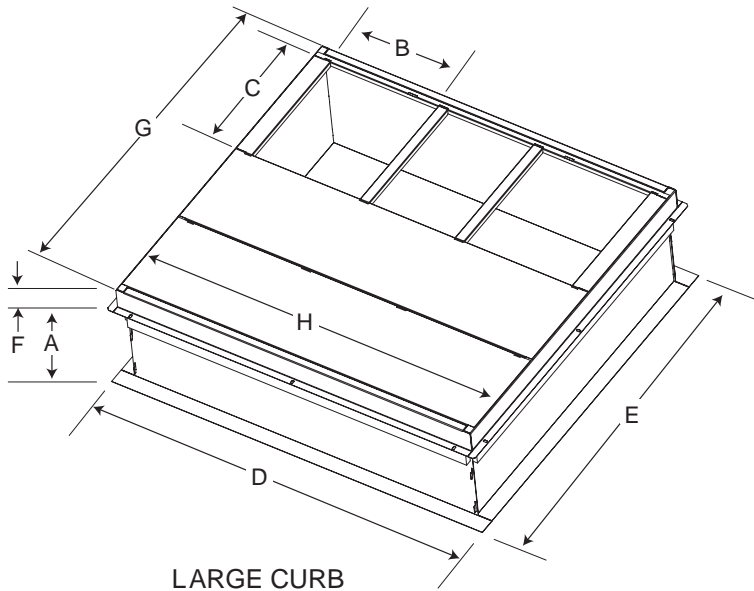

LARGE CURB

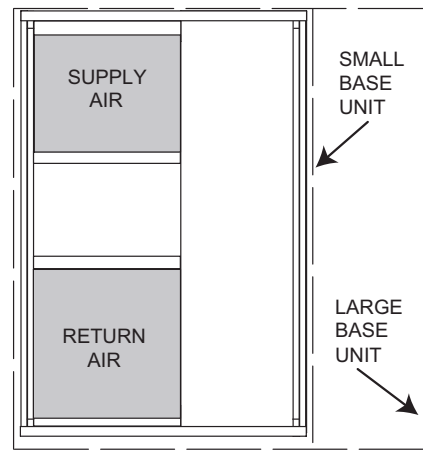

UNIT PLACEMENT ON COMMON CURB

SMALL OR LARGE BASE UNIT

UNIT SIZE	CATALOG NUMBER	A IN. (mm)	B (small/common base) IN. (mm)*	B (large base) IN. (mm)*	C IN. (mm)	D IN. (mm)	E IN. (mm)	F IN. (mm)	G IN. (mm)	H IN. (mm)
Small or Large	CPRFCURB010A00	11 (279)	10 (254)	14 (356)	16 (406)	47.8 (1214)	32.4 (822)	2.7 (69)	30.6 (778)	46.1 (1170)
	CPRFCURB011A00	14 (356)								
Large	CPRFCURB012A00	11 (279)	14 (356)	14 (356)	16 (406)	47.8 (1214)	43.9 (1116)	2.7 (69)	42.2 (1072)	46.1 (1170)
	CPRFCURB013A00	14 (356)								

* Part Numbers CPRFCURB010A00 and CPRFCURB011A00 can be used on both small and large basepan units. The cross supports must be located based on whether the unit is a small basepan or a large basepan.

NOTES:

1. Roof curb must be set up for unit being installed.
2. Seal strip must be applied, as required, to unit being installed.
3. Roof curb is made of 16-gauge steel.
4. Attach ductwork to curb (flanges of duct rest on curb).
5. Insulated panels: 1-in. (25 mm) thick fiberglass 1 lb. density.

PHD4 ACCESSORIES (Continued)						
Accessory Model Number		Description			Use With	
CURBS						
CPRFCURB010A00		Roof Curb, 11" High			24 – 60	
CPRFCURB011A00		Roof Curb, 14" High			24 – 60	
CPRFCURB012A00		Roof Curb, 11" High			36 – 60	
CPRFCURB013A00		Roof Curb, 14" High			36 – 60	
Note: CPRFCURB010A00 AND CPRFCURB011A00 can be used with 42–60 size units with some overhang.						
ADAPTER CURBS*						
CPADCURB001A00		Adapter curb for use with NPRFCURB0006A00 & NPRFCURB007A00			24, 30	
CPADCURB002A00		Adapter curb for use with NPRFCURB0008A00 & NPRFCURB009A00			36 – 60	
* Can also be used when replacing other manufacturer's older generation units that contain a composite base without a metal base rail.						
CONCENTRIC ADAPTERS – (Use with curb only)						
NPCONADP001A00		For 18" round duct (use with curbs CPRFCURB010A00, CPRFCURB011A00)			Small Curb	
NPCONADP002A00		For 18" round duct (use with curbs CPRFCURB012A00, CPRFCURB013A00)			Large Curb	
CONCENTRIC DIFFUSERS – (Ceiling or under roof)						
AXB020CSA*		Step Down Diffuser – Fits 2' x 4' Ceiling Grid (16" round collars for flex conn.)			24 – 42	
AXB020CFA*		Flush Mount Diffuser – Fits 2' x 4' Ceiling Grid (16" round collars for flex conn.)			24 – 42	
AXB030CSA		Step Down Diffuser – Fits 2' x 4' Ceiling Grid (18" round collars for flex conn.)			24 – 60	
AXB030CFA		Flush Mount Diffuser – Fits 2' x 4' Ceiling Grid (18" round collars for flex conn.)			24 – 60	
* A field supplied 18" to 16" round reducer required when used with NP concentric adaptor						
ECONOMIZERS						
CPECOMZR007A00		Dedicated Vertical Economizer – Internal with solid state controller, gear driven, fully modulating damper, spring return actuator, up to 50% barometric relief, supply and dry bulb outdoor air sensors. Includes filter rack with 1" filters*.			24, 30	
CPECOMZR008A00					36, 42	
CPECOMZR009A00					48, 60	
CPECOMZR010A00		Dedicated Horizontal Economizer – Internal with solid state controller, fully modulating damper, spring return actuator, supply and dry bulb outdoor air sensor, and low ambient compressor lockout switch included. Includes filter rack with 1-inch filters*.			24, 30	
CPECOMZR011A00					36, 42	
CPECOMZR012A00					48, 60	
CPRLYKIT001A00		Economizer Relay for Heat Pumps			ALL	
AXB078ENT		Outdoor Enthalpy Control			ALL	
* Outdoor enthalpy available as field installed accessory; Filter rack and 1" filter, same as CPFILTRK kit						
DAMPERS						
CPMANDPR007A00		Manual Outside Air Damper – (Includes filter rack and 1" filter, same as CPFILTRK kit)			24, 30	
CPMANDPR008A00					36, 42	
CPMANDPR009A00					48, 60	
INTERNAL FILTER RACKS						
CPFILTRK007A00		Internal Filter Rack (includes 1–inch filters)			24, 30	
CPFILTRK008A00					36, 42	
CPFILTRK009A00					48, 60	
CRANKCASE HEATERS						
NPCRKHTR008A00		240V Crankcase Heater ((included on 24 & 30 models)			36	
LOW AMBIENT, ANTI–CYCLE TIMER, COMPRESSOR START ASSIST						
CPLOWAMB001A00		Low Ambient Control – enables cooling system to operate down to 0 Deg. F by cycling condenser fan on and off.			ALL	
NRTIMEGD001A00		Five Minute Compressor Delay			ALL	
CPHSTART002A00		PTC Compressor Start Assist Kit			ALL	
HAIL GUARDS / COIL PROTECTION (Factory installed on PHD**000KTP models)						
NAPA00701GR		3/8" spacing dense wire grilles			24, 30	
NAPA00601GR		3/8" spacing dense wire grilles			36	
NAPA01001GR		3/8" spacing dense wire grilles			42, 48	
NAPA01301GR		3/8" spacing dense wire grilles			60	
ELECTRIC HEATERS						
PART NO.		Voltage / Nominal Capacity kW / Fuses		# FUSES	STAGES	USED WITH
EHNA05K0N		3.8 / 5.0		NO	1	24 – 36
EHNA05K4F		3.8 / 5.0		YES	4	ALL
EHNA07K4F		5.4 / 7.2		YES	4	ALL
EHNA10K4F		7.5 / 10.0		YES	4	ALL
EHNA15K6F		11.3 / 15.0		YES	6	30 – 60
EHNA20K6F		15.0 / 20.0		YES	6	42 – 60

PHD4 ACCESSORIES (Continued)

Accessory Model Number	Description	Use With
DUAL POINT WIRING KIT		
CPDUALPT001A00	Dual Point Wiring kit, 5–20kW Heaters	ALL
DUCT TRANSITIONS		
NPDUCFLG002A00	Square to Round (1 set of 2, use with horizontal duct flanges only)	24–48