

PACKAGE HEAT PUMP UNIT - 71 to 114 MBtuh Meets Ashrae 90.1 - Efficiency Standards

REFRIGERATION CIRCUIT

- Scroll compressors on all models.
- High and low pressure switches.
- State of the art defrost system.
- Anti-cycle timer built into the electronic board.

BUILT TO LAST

- Pre-painted galvanized steel cabinet for long life and quality appearance.
- Integral Commercial strength base rails. Holes provided for lifting lugs makes rooftop installation easier.
- Non-corrosive, sloped condensate drain pan, meets ASHRAE 62.

EASY TO INSTALL AND SERVICE

- Electric cooling and heating, self contained for year-round comfort. Systems installed on rooftop or ground level. The unit is shipped in the horizontal position and can easily be converted to downflow.
- Thru-the-bottom utility connection capability allow power and control wiring to be routed through unit base pan, minimizing roof penetrations.
- Factory wired to accept economizer.
- Refrigerant filter drier.

WARRANTY

- 5 year compressor limited warranty
- 1 year parts limited warranty



PHE090-120 Shown



UNIT PERFORMANCE DATA

Model Number *	COOLING			HEATING		Unit Dimensions H X W X L	Unit Weight
	Rated Capacity BTUH	E.E.R	IPLV	ARI Rated Heating Capacity BTUH (Net...High / Low	COP High / Low		
PHE072H000A	71,000	10.5	n/a	69,000 / 37,000	3.4 / 2.2	41-5/16" x 45" x 87-3/8"	630
PHE072L000A	71,000	10.5	n/a	69,000 / 37,000	3.4 / 2.2	41-5/16" x 45" x 87-3/8"	630
PHE090H000A	87,000	10.1	10.5	83,000 / 47,000	3.2 / 2.2	41-5/16" x 57-3/4" x 87-3/8"	940
PHE090L000A	87,000	10.1	10.5	83,000 / 47,000	3.2 / 2.2	41-5/16" x 57-3/4" x 87-3/8"	940
PHE102H000A	98,000	10.3	12.7	96,000 / 52,000	3.3 / 2.2	41-5/16" x 57-3/4" x 87-3/8"	1000
PHE102L000A	98,000	10.3	12.7	96,000 / 52,000	3.3 / 2.2	41-5/16" x 57-3/4" x 87-3/8"	1000
PHE120H000A	114,000	10.1	10.4	112,000 / 63,000	3.2 / 2.2	49-15/16" x 57-3/4" x 87-3/8"	1015
PHE120L000A	114,000	10.1	10.4	112,000 / 63,000	3.2 / 2.2	49-15/16" x 57-3/4" x 87-3/8"	1015

* Unit voltage: H = 208/230v, L = 460v

516 71 1502 01

7/05/07

Table of Contents

	Page
Features/Benefits	1
Model Number Nomenclature	2
Unit Specifications	3-5
Dimensions	6-7
Performance Data	8-14
Typical Installations	15
Accessories	16-25
Electric Heat Accessory	26-28
Controls	29
Guide Specifications	29

MODEL NUMBER IDENTIFICATION GUIDE								
MODEL NUMBER	P	H	E	090	H	000	A	
PRODUCT FAMILY Package Units								Sales Code
TYPE H= Heat Pump G = Gas/Electric A = Air Conditioner								OPTIONS
DESIGN SERIES								VOLTAGE / PHASE / HERTZ H = 208/230-3-60 L = 460-3-60 S = 575-3-60
								COOLING CAPACITY (NOMINAL BTUH) 072 = 6 Ton 102 = 8-1/2 Ton 090 = 7-1/2 Ton 120 = 10 Ton

UNIT SPECIFICATIONS - PHE072 / 090

MODELS				
COOLING	PHE072H	PHE072L	PHE090H	PHE090L
ARI Rated Capacity Btuh (Net)	71,000		87,000	
Nominal Tons	6		7-1/2	
Standard CFM	2400		3100	
EER	10.5		10.1	
IPLV	N/A		10.5	
Sound Rating (Bels)	8.0		8.6	
Unit Operating Weight	630		940	
HEATING				
ARI Rated Heating Capacity Btuh (Net)....High / Low	69,000 / 37,000		83,000 / 47,000	
COP..... High / Low	3.4 / 2.2		3.2 / 2.2	
ELECTRICAL	PHE072H	PHE072L	PHE090H	PHE090L
Volts/ 3 Phase/ 60Hertz	208/230	460	208/230	460
Voltage Range Min/Max	187 / 254	414 / 508	187 / 254	414 / 508
Power Supply MCA	32.8 / 32.8	15.2	38.2 / 38.2	19.2
Power Supply MOCP*	35 / 35	20	40 / 40	20
COMPRESSOR - QTY.	SCROLL - 1		SCROLL - 2	
Model	SR(Y,H,J)682AE *		ZR42K3	
Oil (Oz.)	80		57 each	
RLA / LRA	20.5 / 156.0	9.6 / 70.0	12.4 / 88.0	6.4 / 44.0
REFRIGERANT TYPE				
Expansion Device	Fixed Orifice Metering Device		Fixed Orifice Metering Device	
Operating Charge....lb. oz....Circuit 1	17.7		9 - 1	
.....Circuit 2	N/A		9 - 6	
CONDENSER FAN	Propeller Type			
Nominal CFM	3500		6500	
Quantity..Diameter (In.)	1...22		2...22	
Motor Hp...RPM	1/4...1100		1/4...1100	
FLA	1.4	0.6	1.4	0.7
CONDENSER COIL	Enhanced Copper Tubes, Aluminum Lanced fins			
Rows...Fin/In.	2...17		2...17	
Total Face Area (Sq. Ft.)	21.25		20.50	
EVAPORATOR COIL	Enhanced Copper Tubes, Aluminum Double Wavy Fins			
Rows...Fins/Inche	4...15		3...15	
Total Face Area (sq. ft.)	7.33		8.89	
EVAPORATOR FAN	Centrifugal Type			
Quantity...Size (in.)	1...10 x 10		1...15 x 15	
Type Drive	Belt		Belt	
Nominal CFM	2400		4000	
Max. Continuous Bhp	2.4		4.2	
FLA-208-230/460V	5.8 / 2.6		10.6 / 4.8	
Motor Frame Size	56		56	
Fan RPM Range	1119-1585		860-1080	
Motor Bearing	Ball		Ball	
Maximum Allowable RPM	2100		2100	
Motor Pulley Pitch / Diameter Min/Max. (in.)	2.4 / 3.4		4.0 / 5.0	
Motor Shaft Diameter (in.)	5/8		5/8	
Fan Pulley Pitch Diam (in)	3.7		8.0	
Belt, Quantitiy...Type... Length (in.)	1...A...40		1...A...51	
Pulley Center Line Distance (in)	14.7-15.5		15.85-17.50	

* Y = 208/230 Volt, H = 460 Volt, J = 575 Volt

See legends and notes on page 5.

UNIT SPECIFICATIONS - PHE102 / 120

MODELS				
COOLING	PHE102H	PHE102L	PHE120H	PHE120L
ARI Rated Capacity Btuh (Net)	98,000		114,000	
Nominal Tons	8-1/2		10	
Standard CFM	3400		4000	
EER	10.3		10.1	
IPLV	12.7		10.4	
Sound Rating (Bels)	8.4		8.4	
Unit Operating Weight	1000		1015	
HEATING				
ARI Rated Heating Capacity Btuh (Net)....High / Low	96,000 / 52,000		112,000 / 63,000	
COP..... High / Low	3.3 / 2.2		3.2 / 2.2	
ELECTRICAL	PHE102H	PHE102L	PHE120H	PHE120L
Volts/ 3 Phase/ 60Hertz	208/230	460	208/230	460
Voltage Range Min/Max	187 / 254	414 / 508	187 / 254	414 / 508
Power Supply MCA	41.3 / 41.3	19.2	56.8 / 56.8	28.7
Power Supply MOCPS*	45 / 45	20	60 / 60	30
COMPRESSOR - QTY.	SCROLL - 2		SCROLL - 2	
Model	SR(Y,H,J)482HC *		ZR57K3	
Oil (Oz.)	70 each		57 each	
RLA / LRA	13.9 / 105.0	7.9 / 55.0	19.3 / 123	10.0 / 62.0
REFRIGERANT TYPE	R-22			
Expansion Device	Fixed Orifice Metering Device			
Operating Charge....lb. oz....Circuit 1	11 - 0		10 - 6	
...Circuit 2	11 - 0		9 - 9	
CONDENSER FAN	Propeller Type			
Nominal CFM	6500		6500	
Quantity..Diameter (In.)	2...22		2...22	
Motor Hp...RPM	1/4...1100		1/4...1100	
FLA	1.4	0.7	1.4	0.7
CONDENSER COIL	Enhanced Copper Tubes, Aluminum Lanced fins			
Rows...Fin/In.	2...17		2...17	
Total Face Area (Sq. Ft.)	25.1		25.10	
EVAPORATOR COIL	Enhanced Copper Tubes, Aluminum Double Wavy Fins			
Rows...Fins/Inche	4...15		4...15	
Total Face Area (sq. ft.)	11.1		11.1	
EVAPORATOR FAN	Centrifugal Type			
Quantity...Size (in.)	1...15 x 15		1...15 x 15	
Type Drive	Belt		Belt	
Nominal CFM	3400		4000	
Max. Continuous Bhp	2.9		4.2	
FLA-208-230/460V	7.5 / 3.4		10.6 / 4.8	
Motor Frame Size	56		56	
Fan RPM Range	840-1085		860-1080	
Motor Bearing	Ball		Ball	
Maximum Allowable RPM	1725		2100	
Motor Pulley Pitch / Diameter Min/Max. (in.)	3.4 / 4.4		4.0 / 5.0	
Motor Shaft Diameter (in.)	7/8		7/8	
Fan Pulley Pitch Diam (in)	7.0		8.0	
Belt, Quantity...Type... Length (in.)	1...A...51		1...A...51	
Pulley Center Line Distance (in)	16.75-19.25		15.85-17.50	
Speed Change per Full Turn of Movable Pulley Flange (RPM)	45		45	
Pulley Max. full Turns From Closed Postion	5		5	
Factory Setting	5		5	
Factory Speed Setting RPM	840		860	
Fan Shaft Diam. at Pulley	1		1	

* Y = 208/230 Volt, H = 460 Volt, J = 575 Volt

See Legends and Notes on following page.

UNIT SPECIFICATIONS - PHE072 - 120 (cont.)

MODELS	PHE072	PHE090	PHE102	PHE120
HIGH-PRESSURE SWITCH (psig)				
Standard Compressor		625		
Internal Relief (Differential) Cutout		428		
Reset (Auto.)		320		
LOSS-OF-CHARGE SWITCH (psig) (LOW-PRESS.)				
Cutout		7 +/- 3		
Reset (Auto.)		22 +/- 5		
FREEZE PROTECTION THERMOSTAT (F)				
Opens		30		
Closes		45		
RETURN-AIR FILTERS (THROWAWAY)				
Quantity...Size (in.)	2...16 x 25 x 2	4...16 x 20 x 2	4...20 x 20 x 2	4...20 x 20 x 2

LEGENDS AND NOTES

Bhp = Brake Horsepower

Legend

- Bels - Sound Levels
- EER - Energy Efficiency Ratio
- IPLV - Integrated Part Load Values
- MCA - Minimum Circuit Amps
- MOCP - Maximum Over-current Protection
- FLA - Full Load Amps
- LRA - Locked Rotor Amps
- * - Fuse or HACR circuit breaker
- RLA - Rated Load Amps

- NOTES: 1. Rated in accordance with ARI Standards 210/240, latest revision (for sizes 090, 102 & 120) or 360, latest revision (for size 150).
2. ARI ratings are net values, reflecting the effects of circulating fan heat.
3. Ratings are based on:
Cooling Standard: 80F db, 67F wb indoor entering air temperature and 95F db air entering outdoor unit.
IPLV Standard: 80F db, 67F wb indoor entering air temperature and 80F db entering air temperature.

EXAMPLE: Supply voltage is 460-3-60.

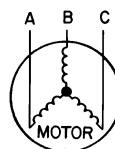

- AB = 452 v
- BC = 464 v
- AC = 455 v

$$\begin{aligned} \text{Average Voltage} &= \frac{452 + 464 + 455}{3} \\ &= \frac{1371}{3} \\ &= 457 \end{aligned}$$

NOTES:

1. In compliance with NEC requirements for multimotor and combination load equipment (refer to NEC Articles 430 and 440), the over-current protective device for the unit shall be fuse or HACR breaker. Canadian units may be fuse or circuit breaker.

2. Unbalanced 3-Phase Supply Voltage

Never operate a motor where a phase imbalance in supply voltage is greater than 2%. Use the following formula to determine the percent voltage imbalance.

$$\% \text{ Voltage Imbalance} = 100 \times \frac{\text{max voltage deviation from average voltage}}{\text{average voltage}}$$

Determine maximum deviation from average voltage.

- (AB) 457 - 452 = 5 V
- (BC) 464 - 457 = 7 V
- (AB) 457 - 455 = 2 V

Maximum deviation is 7 v.

Determine percent voltage imbalance.

$$\begin{aligned} \% \text{ Voltage Imbalance} &= 100 \times \frac{7}{457} \\ &= 1.53\% \end{aligned}$$

This amount of phase imbalance is satisfactory as it is below the maximum allowable 2%.

IMPORTANT: If the supply voltage phase imbalance is more than 2%, contact your local electric utility company immediately.

BASE UNIT WEIGHT AND DIMENSIONS - PHE072

Unit	Total Weight		Corner A		Corner B		Corner C		Corner D		Dim "J"	
	lb	kg	lb	kg	lb	kg	lb	kg	lb	kg	inches	mm
PHE072	630	286	155	70	160	73	159	72	156	71	41 5/16	1050

Measurement in Inches (mm)

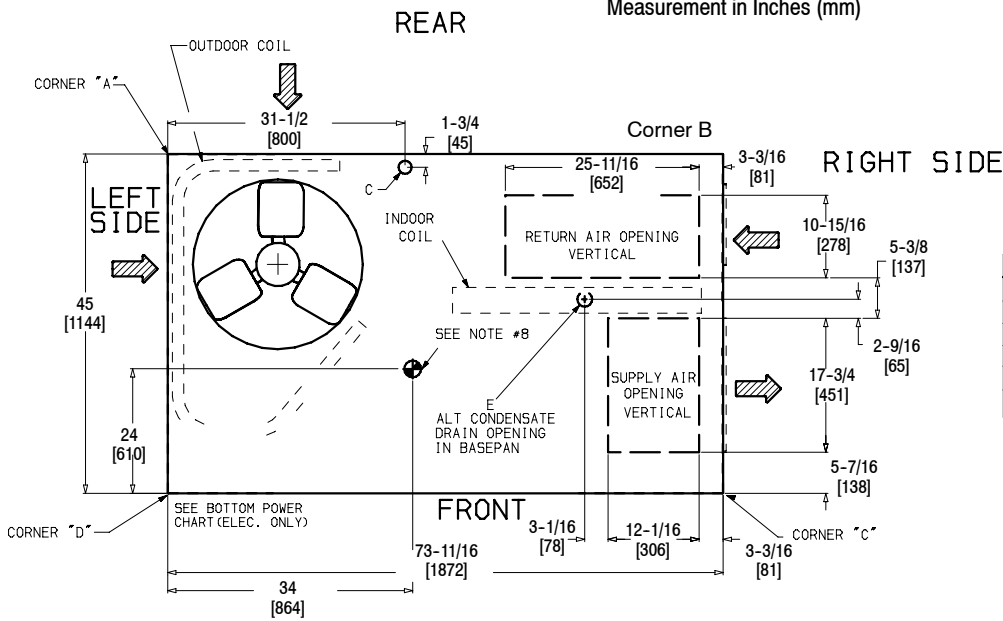

THREADED CONDUIT SIZE	WIRE USE	REQUIRED HOLE SIZES (MAX.)
1/2"	ACC	7/8" [22]
1/2"	24	7/8" [22]
3/4"	Power*	1-1/8" [28.4]
1-1/4" FPT	Power*	1-3/4" [44.4]

* Select either 3/4" or 1-1/4" for power, depending on wire size.

Connection Sizes	
A	1-3/8" Dia (35) Field Power Supply Hole
B	2" Dia (51) Power Supply Knockout
C	1-3/4" Dia (44) Charging Port Hole
D	7/8" Dia (22) Field Control Wiring Hole
E	3/4"-14 NPT Condensate Drain
F	2-1/2" Dia (64) Power Supply Knockout

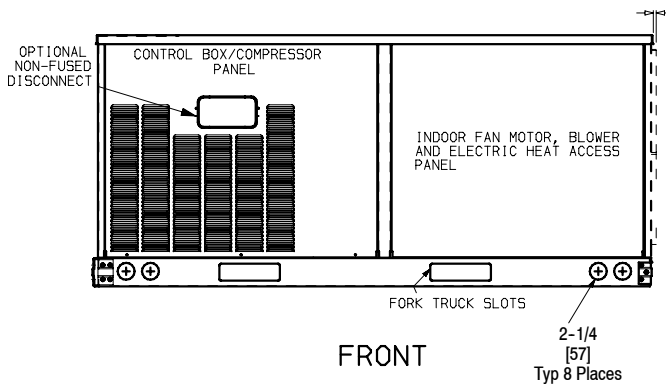
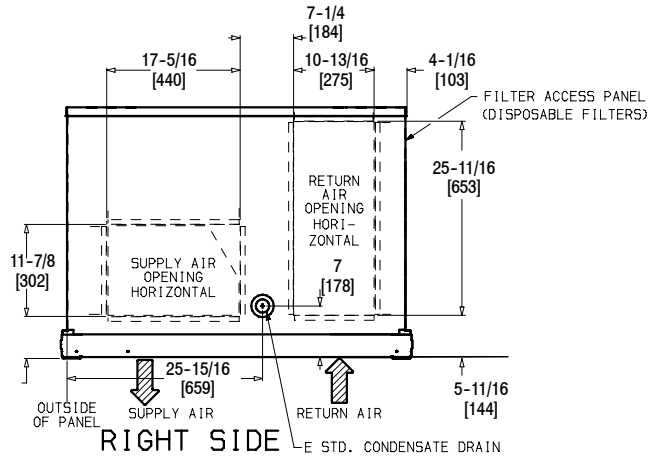
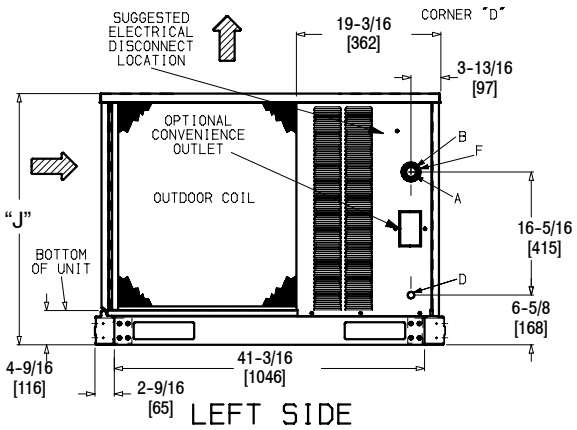

BASE UNIT WEIGHT AND DIMENSIONS - PHE090 - 120

Unit	Total Weight		Corner A		Corner B		Corner C		Corner D		Dim A		Dim B		Dim C	
	lb	kg	lb	kg	lb	kg	lb	kg	lb	kg	inches	mm	inches	mm	inches	mm
PHE090	870	395	198	90	183	83	237	108	252	114	24 7/8	632	41 5/16	1050	33 11/16	856
PHE102	1000	454	231	105	214	97	269	122	286	130	34 7/8	885	49 5/16	1253	36 3/8	924
PHE120	1000	445	223	101	193	88	274	124	325	147	34 7/8	885	49 5/16	1253	36 3/8	924

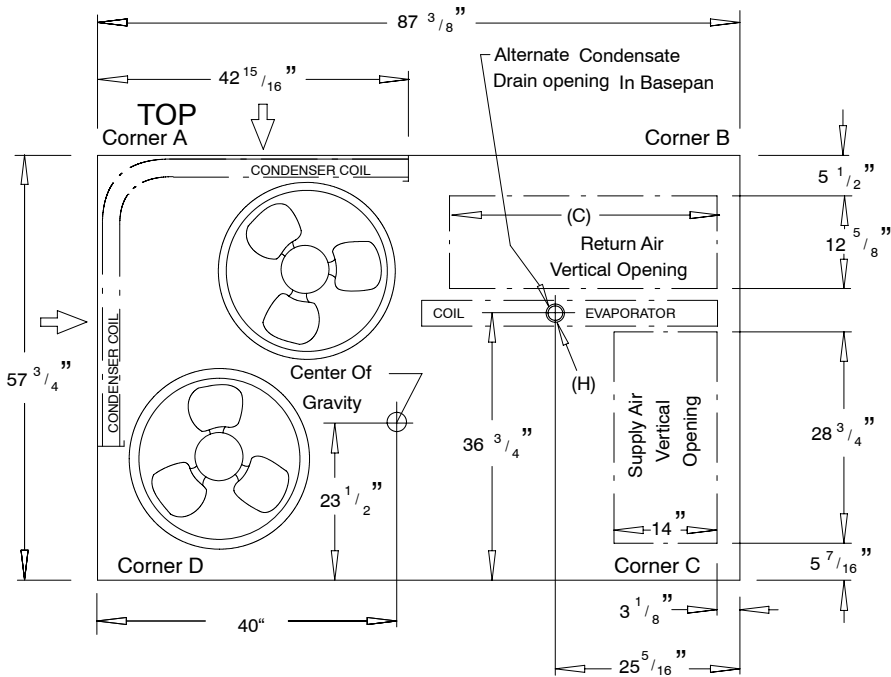

THREADED CONDUIT SIZE	WIRE USE	REQUIRED HOLE SIZES (MAX.)
1/2"	ACC	7/8" [22]
1/2"	24	7/8" [22]
3/4"	Power*	1-1/8" [28.4]
1-1/4" FPT	Power*	1-3/4" [44.4]

* Select either 3/4" or 1-1/4" for power, depending on wire size.

Connection Sizes	
D	1-3/8" Dia (35) Field Power Supply Hole
E	2-1/2" Dia (64) Power Supply Knockout
F	1-3/4" Dia (44) Charging Port Hole
G	7/8" Dia (22) Field Control Wiring Hole
H	3/4"-14 NPT Condensate Drain
I	2" Dia (51) Power Supply Knockout

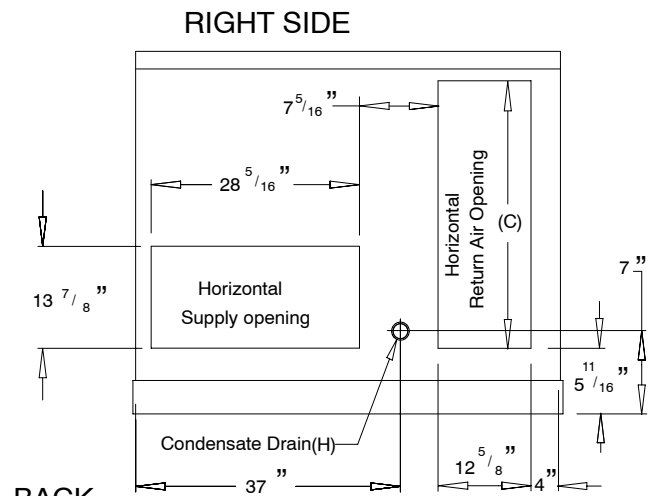
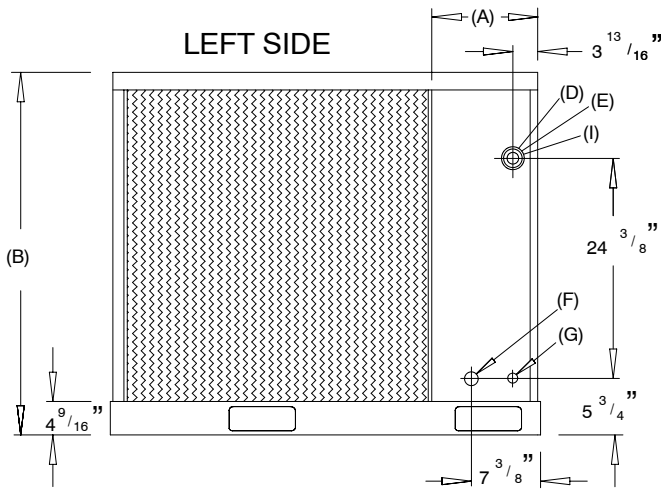

FRONT

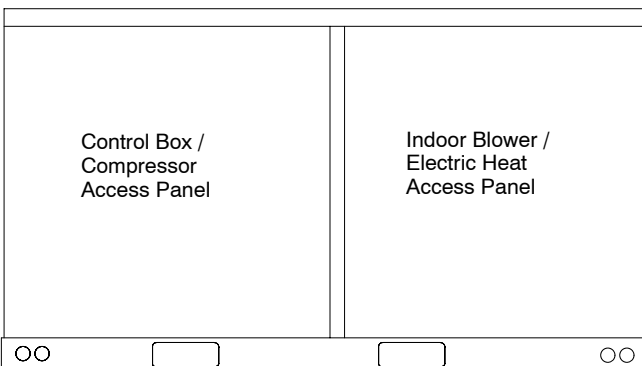

BACK

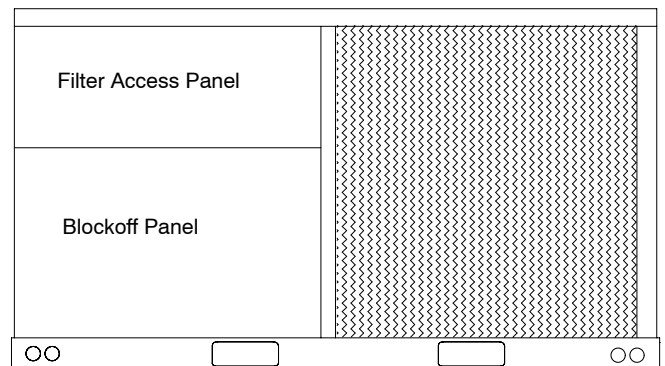

EXPANDED COOLING PERFORMANCE DATA PHE072 6 TON (Gross Capacity)

Temp (F) Outdoor Entering Air (Edb)		Indoor Entering Air — Cfm/BF															
		1800/0.06				2100/0.066				2400/0.071				3000/0.088			
		Indoor Entering Air — Ewb (F)															
		72	67	62	57	72	67	62	57	72	67	62	57	72	67	62	57
75	TC	83.2	77.6	71.6	67.9	84.7	79.8	73.6	71.5	85.9	81.0	75.0	74.3	88.4	82.9	78.4	78.3
	SHC	39.7	50.4	60.6	66.6	41.6	54.3	65.9	70.1	43.4	57.6	70.6	72.8	47.2	63.9	76.9	76.8
	kW	4.90	4.78	4.69	4.63	4.94	4.84	4.71	4.69	4.97	4.86	4.74	4.73	5.04	4.91	4.81	4.81
85	TC	81.5	75.5	69.0	64.8	83.2	77.3	71.1	69.4	84.5	78.5	72.7	72.2	86.2	80.8	76.5	76.5
	SHC	39.2	49.8	59.6	63.6	41.4	53.5	65.0	68.0	43.3	56.9	69.7	70.8	47.1	64.1	75.0	75.0
	kW	5.45	5.34	5.23	5.16	5.49	5.36	5.27	5.23	5.52	5.38	5.29	5.27	5.57	5.45	5.36	5.36
95	TC	78.8	72.5	64.1	61.8	80.9	74.5	67.0	66.1	82.0	76.0	69.9	69.9	83.7	78.1	74.2	74.1
	SHC	38.4	48.6	57.4	60.6	40.8	52.6	63.2	64.8	42.8	56.4	68.3	68.5	46.8	63.7	72.7	72.7
	kW	6.03	5.91	5.79	5.73	6.09	5.96	5.84	5.82	6.11	6.00	5.89	5.89	6.16	6.05	5.96	5.96
105	TC	76.2	69.5	58.6	57.8	77.9	71.3	63.4	63.1	79.3	72.7	67.2	67.2	81.1	74.5	71.3	71.2
	SHC	37.6	47.4	55.0	56.6	39.9	51.4	61.4	61.9	42.2	55.3	65.9	65.9	46.5	62.5	69.9	69.9
	kW	6.69	6.56	6.40	6.38	6.73	6.61	6.45	6.44	6.77	6.64	6.51	6.51	6.82	6.67	6.57	6.57
115	TC	72.5	65.1	54.8	54.7	74.3	67.8	58.6	58.6	75.6	69.1	63.2	63.2	77.3	70.9	68.4	68.4
	SHC	36.3	45.8	53.2	53.6	38.7	50.2	57.4	57.5	41.1	54.0	62.0	62.0	45.5	61.3	67.1	67.1
	kW	7.37	7.24	7.08	7.07	7.43	7.30	7.16	7.16	7.48	7.34	7.21	7.21	7.52	7.38	7.32	7.32

NOTES:
 1. Direct interpolation is permissible. Do not extrapolate.
 2. The following formulas may be used:

$$t_{db} = t_{edb} - \frac{\text{sensible capacity (Btuh)}}{1.10 \times \text{cfm}}$$

$$h_{wb} = h_{ewb} - \frac{\text{total capacity (Btuh)}}{4.5 \times \text{cfm}}$$
 Where: h_{ewb} = Enthalpy of air entering evaporator coil
 3. The SHC is based on 80 F edb temperature of air entering evaporator coil. Below 80 F edb, subtract (corr factor x cfm) from SHC. Above 80 F edb, add (corr factor x cfm) to SHC. Correction Factor = 1.10 x (1 - BF) x (edb - 80).
 Standard Ratings
LEGEND
 BF — Bypass Factor
 Edb — Entering Dry-Bulb
 Ewb — Entering Wet-Bulb
 kW — Compressor Motor Power Input
 SHC — Sensible Heat Capacity (1000 Btuh) Gross
 TC — Total Capacity (1000 Btuh) Gross

EXPANDED HEATING PERFORMANCE DATA PHE072 (Instantaneous and Integrated Heating Ratings)

Return Air (F db)	Cfm (Standard Air)	Temperature Air Entering Outdoor Coil (F db at 70% rh)																				
		-20	-10	0	10	17	30	40	47	50	60	-20	-10	0	10	17	30	40	47	50	60	
55	1800	Cap.	16.5	15.2	20.8	19.1	26.4	22.4	33.6	30.8	41.0	37.6	51.3	44.9	61.9	61.9	69.5	69.5	78.0	78.0	77.9	77.9
		kW	3.50	3.63	3.79	4.01	4.18	4.57	4.94	5.22	5.57	5.55										
	2100	Cap.	16.9	15.5	21.2	19.5	27.2	23.1	34.9	32.0	41.8	38.3	52.2	45.8	63.2	63.2	69.6	69.6	75.7	75.7	76.5	76.5
		kW	3.56	3.68	3.84	4.04	4.18	4.54	4.86	5.07	5.30	5.32										
	2400	Cap.	17.2	15.9	21.8	20.0	28.0	23.8	35.6	32.6	43.1	39.5	53.8	47.2	64.1	64.1	69.0	69.0	74.8	74.8	74.3	74.3
		kW	3.64	3.75	3.89	4.08	4.21	4.54	4.82	4.97	5.18	5.15										
3000	Cap.	18	16.5	23.0	21.1	29.4	25.0	37.4	34.4	45.2	41.4	56.6	49.6	63.2	63.2	65.5	65.5	69.8	69.8	70.6	70.6	
	kW	3.79	3.90	4.03	4.19	4.32	4.61	4.77	4.84	4.98	4.99											
70	1800	Cap.	15.2	14.0	18.2	16.7	24.1	20.5	31.1	28.5	38.0	34.8	47.7	41.8	58.4	58.4	67.1	67.1	78.0	78.0	77.9	77.9
		kW	3.97	4.12	4.33	4.57	4.75	5.19	5.59	5.94	6.43	6.41										
	2100	Cap.	15.6	14.4	18.6	17.1	24.8	21.1	32.0	29.4	39.1	35.9	49.1	43.1	59.7	59.7	68.5	68.5	77.3	77.3	76.7	76.7
		kW	4.04	4.18	4.37	4.59	4.76	5.15	5.51	5.81	6.17	6.13										
	2400	Cap.	16.1	14.8	19.0	17.5	25.9	22.0	32.7	30.0	39.9	36.6	51.1	44.7	61.3	61.3	69.0	69.0	75.6	75.6	76.3	76.3
		kW	4.11	4.24	4.43	4.63	4.79	5.17	5.48	5.73	5.97	5.99										
3000	Cap.	16.8	15.5	19.7	18.1	26.7	22.7	34.3	31.5	41.8	38.3	53.5	46.8	63.7	63.7	68.3	68.3	73.0	73.0	73.8	73.8	
	kW	4.28	4.39	4.56	4.75	4.89	5.22	5.49	5.63	5.80	5.82											
80	1800	Cap.	13.6	12.5	17.1	15.7	21.7	18.4	29.2	26.8	36.5	33.4	45.6	40.0	55.3	55.3	64.2	64.2	77.2	77.2	76.9	76.9
		kW	4.20	4.46	4.67	4.95	5.16	5.62	6.02	6.40	7.00	6.98										
	2100	Cap.	14.1	13.0	17.6	16.2	22.6	19.2	30.1	27.6	37.1	34.0	46.9	41.1	57.0	57.0	66.4	66.4	76.3	76.3	77.2	77.2
		kW	4.28	4.52	4.72	4.98	5.16	5.58	5.95	6.30	6.71	6.74										
	2400	Cap.	14.5	13.4	18.0	16.6	23.1	19.6	31.2	28.7	37.9	32.7	48.5	42.5	58.7	58.7	67.7	67.7	76.3	76.3	75.9	75.9
		kW	4.37	4.59	4.77	5.03	5.19	5.59	5.93	6.23	6.57	6.54										
3000	Cap.	15.4	14.1	18.8	17.3	24.1	20.5	32.2	29.6	39.6	36.3	50.4	44.2	61.6	61.6	68.9	68.9	74.3	74.3	74.5	74.5	
	kW	4.54	4.74	4.91	5.14	5.29	5.64	5.95	6.17	6.37	6.36											

LEGEND
 Cap. — Heating Capacity (1000 Btuh) (includes indoor-fan motor heat)
 kW — Total Power Input (includes compressor motor power input, outdoor-fan motor input, and indoor-fan motor input)
 rh — Relative Humidity
NOTES:
 1. [Shaded] indicates integrated ratings.
 2. Integrated capacity is maximum (instantaneous) capacity less the effect of frost on the outdoor coil and the heat required to defrost it.

EXPANDED COOLING PERFORMANCE DATA PHE090 7-1/2 Ton (GROSS Capacity)

Airflow CFM IDB (BF)			Outdoor Ambient Temperature - Degrees F, Dry Bulb														
			75			85			95			105			115		
			Entering Indoor Air Temperature - Degrees F, Wet Bulb														
			62	67	72	62	67	72	62	67	72	62	67	72	62	67	72
80	3750 (0.18)	MBH	90.3	96.3	100.1	88.6	94.6	100.9	86.0	92.3	98.1	82.1	88.7	95.5	77.6	84.0	92.5
		S/T	0.98	0.76	0.54	0.99	0.77	0.54	1.00	0.80	0.55	1.00	0.82	0.56	1.00	0.85	0.59
		KW	5.64	5.73	5.77	6.40	6.48	6.59	7.24	7.32	7.39	8.14	8.22	8.31	9.08	9.19	9.34
	3200	MBH	89.0	94.7	99.5	86.2	93.2	99.1	82.0	90.6	97.1	77.2	86.7	94.0	73.1	81.3	90.9
		S/T	0.94	0.72	0.52	0.96	0.74	0.52	0.98	0.76	0.53	1.00	0.78	0.54	1.00	0.80	0.56
		KW	5.68	5.70	5.77	6.49	6.47	6.56	7.20	7.30	7.39	8.06	8.21	8.28	9.00	9.15	9.31
	3000 (0.15)	MBH	88.6	94.2	99.3	85.4	92.7	98.5	80.6	89.9	96.7	75.5	86.0	93.4	71.4	80.4	90.3
		S/T	0.93	0.70	0.51	0.95	0.72	0.52	0.98	0.74	0.53	1.00	0.76	0.54	1.00	0.79	0.55
		KW	5.69	5.69	5.77	6.52	6.46	6.55	7.19	7.30	7.39	8.03	8.21	8.26	8.97	9.13	9.30
	2250 (0.12)	MBH	83.0	91.1	96.1	78.6	88.6	95.7	73.9	85.6	93.0	69.6	81.0	90.3	65.9	76.2	86.4
		S/T	0.86	0.66	0.49	0.88	0.67	0.49	0.91	0.68	0.50	0.93	0.70	0.50	0.96	0.72	0.51
		KW	5.64	5.67	5.71	6.33	6.40	6.51	7.08	7.26	7.32	7.92	8.10	8.24	8.85	9.02	9.19

FORMULAS AND NOTES FOR USING EXPANDED PERFORMANCE DATA

To find leaving wet bulb and dry bulb from the expanded performance charts, use the following formulas.

- Direct interpolation is permissible. Do not extrapolate.
- The following formulas may be used:
 - $t/db = t\ edb - \text{sensible capacity Btuh} / (1.10 \times \text{cfm})$
 - $t/wb = \text{Wet bulb temp. corresponding to enthalpy of air leaving evaporator coil (h/wb)}$
 - $h/wb = h\ ewb - \text{total capacity Btuh} / (4.5 \times \text{cfm})$
where h ewb = Enthalpy of air entering evap. coil
- The SHC is based on 80F edb of air entering evap coil.
Below 80F edb, subtract (corr factor x cfm) from SHC.
Above 80F edb, add (corr factor x cfm) to SHC.

LEGEND	
MBH	= Total Capacity (Gross)
S/T	= Sensible to Total Ratio
KW	= Compressor Motor Power Input.
IDB	= Indoor Dry Bulb
edb	= Entering Dry Bulb
ewb	= Entering Wet Bulb
t/db	= Leaving Dry Bulb
t/wb	= Leaving Wet Bulb
h/wb	= Enthalpy of Leaving Wet Bulb
SHC	= Sensible Heat Capacity

BYPASS FACTOR (BF)	ENTERING AIR DRY BULB						Use formulas shown below
	79	78	77	76	75	under 75	
	81	82	83	84	85	over 85	
Correction Factor							
.05	1.04	2.07	3.11	4.14	5.18		
.10	0.98	1.96	2.94	3.92	4.90		
.20	0.87	1.74	2.62	3.49	4.36		
.30	0.76	1.53	2.29	3.05	3.82		

Correction Factor = 1.10 x (1-BF) x (edb-80).

EXPANDED HEATING PERFORMANCE DATA PHE090 (Instantaneous and Integrated Heating Ratings)

Return Air 70 deg. F		Outdoor Ambient Temperature - Degrees F, Dry Bulb															
		60		50		47		40		30		17		10		0	
3750 cfm	MBH	103.9	103.9	91.9	91.9	88.3	88.3	80.5	80.5	71.0	62.4	59.1	53.9	53.5	49.1	46.1	43.1
	KW	8.75		8.40		8.30		8.10		7.42		7.17		7.07		6.90	
3000 cfm	MBH	103.7	103.7	90.0	90.0	86.2	86.2	78.5	78.5	69.1	60.6	57.3	52.3	51.7	47.5	44.4	41.0
	KW	8.48		8.04		7.91		7.71		7.03		6.79		6.67		6.50	
2250 cfm	MBH	101.7	101.7	87.9	87.9	84.3	84.3	76.6	76.6	67.4	59.1	55.6	50.6	50.0	45.9	42.5	39.2
	KW	8.23		7.77		7.65		7.43		6.75		6.44		6.30		6.12	

LEGEND: Mbtu = Heating Capacity (1000 btuh) includes indoor fan motor heat).
KW = Total Power input (includes compressor motor power).

NOTES: Integrated capacity - maximum instantaneous capacity less effect of frost on outdoor coil and heat required to defrost it.

EXPANDED COOLING PERFORMANCE DATA PHE102 8-1/2 TON (Gross Capacity)

Temp (F) Outdoor Entering Air (Edb)		Indoor Entering Air — Cfm/BF								
		2550/0.03			3400/0.04			4250/0.05		
		Indoor Entering Air — Ewb (F)								
		72	67	62	72	67	62	72	67	62
75	TC	116.4	105.6	94.8	118.9	110.4	99.4	120.4	112.9	104.3
	SHC	55.7	69.2	82.0	58.6	79.7	95.8	61.6	89.2	104.2
	kW	6.01	5.89	5.8	6.04	5.97	5.87	6.07	6.01	5.93
85	TC	117.6	102.1	91.1	121.0	106.7	95.6	117.5	109.3	101.3
	SHC	58.4	67.9	80.4	64.1	78.6	93.9	61.0	88.4	101.2
	kW	6.47	6.72	6.61	6.52	6.80	6.69	6.91	6.85	6.77
95	TC	113.7	98.0	86.1	117.4	102.3	91.3	113.4	104.7	97.9
	SHC	57.4	66.5	78.2	63.5	77.2	91.1	59.9	87.2	97.8
	kW	7.34	7.63	7.49	7.40	7.72	7.60	7.82	7.77	7.69
105	TC	109.8	93.0	78.7	113.2	97.3	85.9	108.9	99.9	93.7
	SHC	56.2	64.6	75.0	62.4	75.5	85.9	58.7	85.5	93.6
	kW	8.28	8.59	8.42	8.36	8.71	8.57	8.81	8.74	8.68
115	TC	100.2	86.4	72.7	104.5	90.0	80.8	106.0	93.2	88.0
	SHC	50.4	62.1	71.9	57.2	73.0	80.8	63.4	83.2	88.0
	kW	9.79	9.60	9.40	9.91	9.71	9.59	9.95	9.79	9.71
125	TC	94.0	76.6	63.1	98.8	80.1	68.1	101.0	84.4	75.1
	SHC	48.3	58.5	63.1	55.4	69.2	68.1	61.9	79.8	75.1
	kW	10.91	10.65	10.45	11.03	10.78	10.61	11.1	10.86	10.73

NOTES:

- Direct interpolation is permissible. Do not extrapolate.
- The following formulas may be used:

$$t_{db} = t_{edb} - \frac{\text{sensible capacity (Btuh)}}{1.10 \times \text{cfm}}$$

$$t_{wb} = \text{Wet-bulb temperature corresponding to enthalpy of air leaving evaporator coil (} h_{wb} \text{)}$$

$$h_{wb} = h_{ewb} - \frac{\text{total capacity (Btuh)}}{4.5 \times \text{cfm}}$$
- The SHC is based on 80 F edb temperature of air entering evaporator coil. Below 80 F edb, subtract (corr factor x cfm) from SHC. Above 80 F edb, add (corr factor x cfm) to SHC. Correction Factor = 1.10 x (1 - BF) x (edb - 80).

Standard Ratings

LEGEND

- BF — Bypass Factor
- Edb — Entering Dry-Bulb
- Ewb — Entering Wet-Bulb
- kW — Compressor Motor Power Input
- SHC — Sensible Heat Capacity (1000 Btuh) Gross
- TC — Total Capacity (1000 Btuh) Gross

EXPANDED HEATING PERFORMANCE DATA PHE102 (Instantaneous and Integrated Heating Ratings)

Return Air (F db)	Cfm (Standard Air)	Temperature Air Entering Outdoor Coil (F db at 70% rh)																						
		-20		-10		0		10		20		30		40		47		50		60				
55	2550	Cap.	31.6	29.1	39.1	36.0	47.2	43.5	56.3	51.8	65.4	59.3	75.3	66.0	86.1	86.1	97.9	97.9	108.0	108.0	113.5	113.5		
		kW	3.73	4.01	4.30	4.66	5.01	5.37	5.79	6.23	6.52	6.80	7.09	7.37	7.65	7.93	8.21	8.49	8.77	9.05	9.33	9.61	9.89	
	3400	Cap.	32.9	30.2	40.5	37.2	48.3	44.5	57.5	52.7	66.5	60.3	76.5	67.1	87.5	87.5	97.4	97.4	106.1	106.1	109.9	109.9		
		kW	3.62	3.86	4.10	4.39	4.67	4.96	5.29	5.54	5.71	5.89	6.17	6.41	6.65	6.89	7.13	7.37	7.61	7.85	8.09	8.33	8.57	8.81
	4250	Cap.	33.9	31.2	41.5	38.1	49.3	45.4	58.5	53.6	67.5	61.2	77.6	67.9	86.6	86.6	94.6	94.6	102.5	102.5	105.6	105.6		
		kW	3.55	3.77	3.98	4.23	4.47	4.72	4.92	5.09	5.21	5.33	5.51	5.69	5.87	6.05	6.23	6.41	6.59	6.77	6.95	7.13	7.31	7.49
70	2550	Cap.	28.9	26.6	36.9	34.0	45.5	41.8	55.0	50.5	64.4	58.4	74.2	65.0	84.5	84.5	95.8	95.8	107.1	107.1	114.3	114.3		
		kW	4.38	4.76	5.14	5.54	5.98	6.45	6.92	7.41	7.82	8.26	8.71	9.16	9.61	10.06	10.51	10.96	11.41	11.86	12.31	12.76	13.21	13.66
	3400	Cap.	30.2	27.8	38.4	35.3	46.9	43.0	56.4	51.8	65.6	59.5	75.4	66.1	86.0	86.0	97.4	97.4	107.3	107.3	111.9	111.9		
		kW	4.27	4.61	4.91	5.25	5.61	5.98	6.36	6.74	7.12	7.50	7.88	8.26	8.64	9.02	9.40	9.78	10.16	10.54	10.92	11.30	11.68	12.06
	4250	Cap.	31.4	28.8	39.5	36.4	47.9	44.2	57.5	52.7	66.6	60.4	76.4	67.0	87.1	87.1	97.2	97.2	106.3	106.3	109.1	109.1		
		kW	4.21	4.51	4.79	5.09	5.40	5.70	6.03	6.28	6.46	6.60	6.79	6.98	7.17	7.36	7.55	7.74	7.93	8.12	8.31	8.50	8.69	8.88
80	2550	Cap.	26.3	24.2	34.9	32.1	43.8	40.3	53.6	49.2	63.3	57.4	73.4	64.3	83.7	83.7	94.4	94.4	106.5	106.5	112.5	112.5		
		kW	4.82	5.27	5.72	6.19	6.66	7.21	7.76	8.29	8.79	9.23	9.73	10.23	10.73	11.23	11.73	12.23	12.73	13.23	13.73	14.23	14.73	15.23
	3400	Cap.	27.8	25.5	36.4	33.5	45.3	41.7	55.1	50.6	64.7	58.7	74.7	65.4	85.0	85.0	96.2	96.2	107.1	107.1	110.0	110.0		
		kW	4.72	5.11	5.49	5.88	6.28	6.72	7.14	7.57	7.99	8.41	8.83	9.25	9.67	10.09	10.51	10.93	11.35	11.77	12.19	12.61	13.03	13.45
	4250	Cap.	29.0	26.7	37.6	34.7	46.4	42.7	56.5	51.8	65.9	59.6	75.7	66.4	86.2	86.2	96.9	96.9	106.2	106.2	110.8	110.8		
		kW	4.66	5.02	5.35	5.70	6.05	6.42	6.79	7.11	7.34	7.54	7.74	7.94	8.14	8.34	8.54	8.74	8.94	9.14	9.34	9.54	9.74	9.94

LEGEND

- Cap. — Heating Capacity (1000 Btuh) (includes indoor-fan motor heat)
- kW — Total Power Input (includes compressor motor power input, outdoor-fan motor input, and indoor-fan motor input)
- rh — Relative Humidity

NOTES:

- Indicates integrated ratings.
- Integrated capacity is maximum (instantaneous) capacity less the effect of frost on the outdoor coil and the heat required to defrost it.

EXPANDED COOLING PERFORMANCE DATA PHE120 10 Ton (GROSS Capacity)

Airflow CFM IDB (BF)			Outdoor Ambient Temperature - Degrees F, Dry Bulb														
			75			85			95			105			115		
			Entering Indoor Air Temperature - Degrees F, Wet Bulb														
			62	67	72	62	67	72	62	67	72	62	67	72	62	67	72
80	5000 (0.06)	MBH	119.4	130.0	143.4	116.2	125.5	138.3	112.5	120.0	134.2	108.0	114.3	128.4	103.0	107.6	121.7
		S/T	1.00	0.78	0.54	1.00	0.81	0.55	1.00	0.83	0.56	1.00	0.86	0.58	1.00	0.89	0.59
		KW	7.28	7.42	7.60	8.15	8.27	8.45	9.10	9.22	9.42	10.19	10.27	10.47	11.34	11.43	11.58
	4000 (0.04)	MBH	114.9	127.1	139.1	110.3	122.5	135.5	105.6	117.6	131.2	99.9	111.9	125.5	93.4	105.0	119.4
		S/T	0.96	0.72	0.50	0.98	0.73	0.51	1.00	0.75	0.52	1.00	0.77	0.53	1.00	0.80	0.54
		KW	7.18	7.34	7.50	8.05	8.21	8.37	9.01	9.16	9.34	10.07	10.19	10.37	11.18	11.34	11.50
	3000 (0.03)	MBH	109.7	122.1	134.0	105.0	117.8	130.6	97.9	112.9	125.9	90.6	107.2	120.6	85.3	100.3	115.0
		S/T	0.86	0.65	0.48	0.88	0.66	0.48	0.91	0.68	0.49	0.95	0.69	0.49	0.98	0.72	0.50
		KW	7.09	7.24	7.40	7.97	8.11	8.27	8.87	9.04	9.22	9.87	10.11	10.25	10.98	11.20	11.41

FORMULAS AND NOTES FOR USING EXPANDED PERFORMANCE DATA

To find leaving wet bulb and dry bulb from the expanded performance charts, use the following formulas.

- Direct interpolation is permissible. Do not extrapolate.
- The following formulas may be used:
 - $t/db = t\ edb - \text{sensible capacity Btuh} / (1.10 \times \text{cfm})$
 - $t/wb = \text{Wet bulb temp. corresponding to enthalpy of air leaving evaporator coil (h/wb)}$
 - $h/wb = h\ ewb - \text{total capacity Btuh} / (4.5 \times \text{cfm})$
where h ewb = Enthalpy of air entering evap. coil
- The SHC is based on 80F edb of air entering evap coil. Below 80F edb, subtract (corr factor x cfm) from SHC. Above 80F edb, add (corr factor x cfm) to SHC.

LEGEND	
MBH	= Total Capacity (Gross)
S/T	= Sensible to Total Ratio
KW	= Compressor Motor Power Input.
IDB	= Indoor Dry Bulb
edb	= Entering Dry Bulb
ewb	= Entering Wet Bulb
t/db	= Leaving Dry Bulb
t/wb	= Leaving Wet Bulb
h/wb	= Enthalpy of Leaving Wet Bulb
SHC	= Sensible Heat Capacity

BYPASS FACTOR (BF)	ENTERING AIR DRY BULB						Use formulas shown below
	79	78	77	76	75	under 75	
	81	82	83	84	85	over 85	
	Correction Factor						
.05	1.04	2.07	3.11	4.14	5.18		
.10	0.98	1.96	2.94	3.92	4.90		
.20	0.87	1.74	2.62	3.49	4.36		
.30	0.76	1.53	2.29	3.05	3.82		

Correction Factor = 1.10 x (1-BF) x (edb-80).

EXPANDED HEATING PERFORMANCE DATA PHE120 (Instantaneous and Integrated Heating Ratings)

Return Air 70 deg. F		Outdoor Ambient Temperature - Degrees F, Dry Bulb															
		60		50		47		40		30		17		10		0	
5000 cfm	MBH	131.7	131.7	116.4	116.4	111.8	111.8	101.9	101.9	85.4	75.0	71.0	64.7	64.2	58.9	55.5	51.0
	KW	10.76		10.33		10.21		9.96		9.58		9.27		9.14		8.92	
4000 cfm	MBH	131.4	131.4	114.1	114.1	109.1	109.1	99.5	99.5	83.0	72.9	68.9	62.8	62.2	57.0	53.4	49.2
	KW	10.43		9.89		9.73		9.49		9.09		8.78		8.63		8.40	
3000 cfm	MBH	128.7	128.7	111.3	111.3	106.8	106.8	97.0	97.0	81.0	71.0	66.8	60.8	60.1	55.3	51.0	47.1
	KW	10.14		9.56		9.41		9.14		8.73		8.32		8.16		7.91	

LEGEND: Mbtu = Heating Capacity (1000 btuh) includes indoor fan motor heat).

KW = Total Power input (includes compressor motor power).

NOTES: Integrated capacity - maximum instantaneous capacity less effect of frost on outdoor coil and heat required to defrost it.

CIRCULATING BLOWER PERFORMANCE - PHE072 - Standard Motor (Belt Drive)* (Horizontal Discharge)

Airflow CFM	EXTERNAL STATIC PRESSURE (in. wg)																			
	0.2		0.4		0.6		0.8		1.0		1.2		1.4		1.6		1.8		2.0	
	RPM	Watts	RPM	Watts	RPM	Watts	RPM	Watts	RPM	Watts	RPM	Watts	RPM	Watts	RPM	Watts	RPM	Watts	RPM	Watts
1800	822	455	927	589	1018	728	1100	873	1174	1024	1244	1182	1308	1345	1369	1513	1427	1687	1483	1867
1900	855	520	957	659	1046	805	1127	956	1200	1113	1268	1275	1332	1443	1393	1617	1450	1796	1505	1979
2000	889	591	988	737	1075	888	1154	1045	1226	1208	1294	1376	1357	1549	1417	1727	1474	1911	1528	2100
2100	923	668	1019	821	1104	979	1182	1142	1253	1310	1320	1483	1382	1662	1441	1845	1498	2034	-	-
2200	957	753	1051	912	1134	1077	1210	1245	1280	1419	1346	1598	1408	1782	1466	1971	-	-	-	-
2300	992	845	1083	1011	1164	1182	1239	1357	1308	1537	1372	1721	1434	1911	1491	2105	-	-	-	-
2400	1026	945	1115	1118	1195	1295	1268	1476	1336	1662	1400	1852	1460	2047	-	-	-	-	-	-
2500	1061	1053	1148	1233	1226	1416	1297	1604	1364	1796	1427	1992	-	-	-	-	-	-	-	-
2600	1097	1169	1181	1356	1257	1546	1327	1740	1393	1938	-	-	-	-	-	-	-	-	-	-
2700	1132	1294	1214	1487	1289	1684	1358	1885	1422	2089	-	-	-	-	-	-	-	-	-	-
2800	1168	1428	1247	1629	1320	1832	1388	2039	-	-	-	-	-	-	-	-	-	-	-	-
2900	1204	1572	1281	1779	1353	1989	-	-	-	-	-	-	-	-	-	-	-	-	-	-
3000	1240	1725	1315	1939	-	-	-	-	-	-	-	-	-	-	-	-	-	-	-	-

LEGEND

Watts = Input Watts to motor.

* Motor drive range: 1119 to 1585 rpm. All other rpms require a field-supplied drive.

Maximum continuous bhp is 2.40.

CIRCULATING BLOWER PERFORMANCE - PHE090 - Standard Motor (Belt Drive)* (Horizontal Discharge)

Airflow CFM	EXTERNAL STATIC PRESSURE (in. wg)																			
	0.2		0.4		0.6		0.8		1.0		1.2		1.4		1.6		1.8		2.0	
	RPM	Watts	RPM	Watts	RPM	Watts	RPM	Watts	RPM	Watts	RPM	Watts	RPM	Watts	RPM	Watts	RPM	Watts	RPM	Watts
2250	465	402	555	596	629	802	694	1021	753	1252	806	1494	856	1747	903	2009	947	2282	988	2564
2300	471	421	560	618	634	828	698	1050	757	1283	810	1528	859	1784	907	2048	950	2323	992	2607
2400	483	461	570	665	644	881	708	1109	765	1348	818	1599	868	1859	915	2129	958	2410	1000	2698
2500	495	503	581	715	653	937	717	1171	774	1416	827	1672	876	1938	923	2214	966	2499	-	-
2550	501	526	586	740	658	967	722	1204	779	1452	832	1710	880	1979	927	2258	971	2545	-	-
2600	507	549	592	767	663	996	727	1237	784	1488	836	1749	885	2021	931	2302	975	2592	-	-
2700	519	597	603	823	674	1059	736	1306	793	1563	845	1830	893	2107	940	2394	983	2689	-	-
2800	532	649	614	882	684	1125	746	1378	802	1641	854	1914	902	2197	948	2488	-	-	-	-
2900	544	703	625	944	694	1194	756	1453	812	1723	863	2002	912	2290	957	2587	-	-	-	-
3000	557	761	637	1009	705	1266	766	1533	821	1808	872	2093	921	2388	966	2691	-	-	-	-
3100	570	823	648	1079	716	1342	776	1615	831	1897	882	2189	930	2489	-	-	-	-	-	-
3200	582	888	660	1151	727	1422	786	1702	841	1991	892	2288	939	2595	-	-	-	-	-	-
3300	595	957	671	1228	738	1506	797	1792	851	2088	901	2391	948	2704	-	-	-	-	-	-
3400	608	1030	683	1308	749	1593	807	1887	861	2188	911	2499	-	-	-	-	-	-	-	-
3500	622	1103	695	1392	760	1685	818	1985	872	2294	921	2610	-	-	-	-	-	-	-	-
3600	635	1187	707	1481	771	1781	829	2088	882	2403	-	-	-	-	-	-	-	-	-	-
3700	648	1272	720	1573	783	1881	840	2195	892	2517	-	-	-	-	-	-	-	-	-	-
3750	655	1316	726	1621	789	1932	845	2250	897	2575	-	-	-	-	-	-	-	-	-	-

LEGEND

Watts = Input Watts to motor.

* Motor drive range: 840 to 1085 rpm. All other rpms require a field-supplied drive.

CIRCULATING BLOWER PERFORMANCE - PHE102 - Standard Motor (Belt Drive) (Horizontal Discharge)																					
Airflow CFM		EXTERNAL STATIC PRESSURE (in. wg)																			
		0.2		0.4		0.6		0.8		1.0		1.2		1.4		1.6		1.8		2.0	
		RPM	Watts	RPM	Watts	RPM	Watts	RPM	Watts	RPM	Watts	RPM	Watts	RPM	Watts	RPM	Watts	RPM	Watts	RPM	Watts
2500	462	348	541	467	614	594	681	728	744	868	804	1013	861	1164	915	1319	967	1479	1017	1642	
2600	474	381	551	505	622	635	688	773	750	916	809	1065	864	1219	918	1378	969	1541	1018	1708	
2700	486	417	561	545	630	679	695	820	756	967	813	1119	869	1277	921	1439	972	1606	1021	1776	
2800	498	456	571	587	639	725	702	870	762	1020	819	1176	873	1337	925	1503	975	1673	1023	1847	
2900	510	497	581	632	648	774	710	922	768	1076	824	1235	878	1400	929	1569	978	1742	1026	1920	
3000	523	541	592	680	657	825	718	977	775	1135	830	1298	883	1466	934	1638	982	1815	1029	1996	
3100	536	587	603	730	666	879	726	1035	783	1196	837	1363	889	1534	938	1710	986	1891	1033	2075	
3200	549	637	614	783	676	936	735	1096	790	1260	843	1431	894	1606	944	1785	991	1969	1037	2157	
3300	562	689	626	839	686	996	743	1159	798	1328	850	1502	901	1680	949	1863	996	2051	1041	2242	
3400	575	744	637	898	696	1059	752	1226	806	1398	858	1576	907	1758	955	1944	1001	2135	1046	2331	
3500	588	802	649	961	707	1125	762	1296	815	1472	865	1653	914	1838	961	2029	1007	2223	1051	2422	
3600	601	864	661	1026	717	1194	771	1369	823	1548	873	1733	921	1922	967	2116	1012	2314	1056	2516	
3700	614	929	673	1095	728	1267	781	1445	832	1629	881	1816	928	2010	974	2207	1019	2409	1062	2615	
3800	628	997	685	1167	739	1343	791	1525	841	1712	889	1904	936	2100	981	2302	1025	2507	-	-	
3900	641	1069	697	1243	750	1423	801	1608	850	1799	898	1995	944	2195	988	2399	1032	2608	-	-	
4000	655	1144	709	1322	761	1506	812	1695	860	1890	907	2089	952	2293	996	2501	-	-	-	-	
4100	668	1223	722	1405	773	1593	822	1786	870	1984	916	2187	960	2395	1004	2607	-	-	-	-	
4200	682	1305	734	1492	784	1683	833	1880	880	2082	925	2289	969	2500	-	-	-	-	-	-	
4300	696	1392	747	1582	796	1777	844	1979	890	2184	934	2395	978	2610	-	-	-	-	-	-	

LEGEND

Watts = Input Watts to motor.

* Motor drive range: 840 to 1085 rpm. All other rpms require a field-supplied drive.

Maximum continuous bhp is 2.90.

CIRCULATING BLOWER PERFORMANCE - PHE120 - Standard Motor (Belt Drive) (Horizontal Discharge)																					
Airflow CFM		EXTERNAL STATIC PRESSURE (in. wg)																			
		0.2		0.4		0.6		0.8		1.0		1.2		1.4		1.6		1.8		2.0	
		RPM	Watts	RPM	Watts	RPM	Watts	RPM	Watts	RPM	Watts	RPM	Watts	RPM	Watts	RPM	Watts	RPM	Watts	RPM	Watts
3000	523	541	592	680	657	825	718	977	775	1135	830	1298	883	1466	934	1638	982	1815	1029	1996	
3100	536	587	603	730	666	879	726	1035	783	1195	837	1363	889	1534	938	1710	986	1891	1033	2075	
3200	549	637	614	783	676	936	735	1096	790	1260	843	1431	894	1606	944	1785	991	1969	1037	2157	
3300	562	689	626	839	686	996	743	1159	798	1328	850	1502	901	1680	949	1863	996	2051	1041	2242	
3400	575	744	637	898	696	1059	752	1226	806	1398	858	1576	907	1758	955	1944	1001	2135	1046	2331	
3500	588	802	649	961	707	1125	762	1296	815	1472	865	1653	914	1838	961	2029	1007	2223	1051	2422	
3600	601	864	661	1026	717	1194	771	1369	823	1548	873	1733	921	1922	967	2116	1012	2314	1056	2516	
3700	614	929	673	1095	728	1267	781	1445	832	1629	881	1816	928	2010	974	2207	1019	2409	1062	2615	
3800	628	997	685	1167	739	1343	791	1525	841	1712	889	1904	936	2100	981	2302	1025	2507	1068	2716	
3900	641	1069	697	1243	750	1423	801	1608	850	1799	898	1995	944	2195	988	2399	1032	2608	1074	2821	
4000	655	1144	709	1322	761	1506	812	1695	860	1890	907	2089	952	2293	996	2501	1038	2713	1080	2930	
4100	668	1223	722	1405	773	1593	822	1786	870	1984	916	2187	960	2395	1004	2607	1046	2822	1087	3042	
4200	682	1305	734	1492	784	1683	833	1880	880	2082	925	2289	969	2500	1011	2716	1053	2935	1094	3159	
4300	696	1392	747	1582	796	1777	844	1979	890	2184	934	2395	978	2610	1020	2828	1061	3052	1101	3279	
4400	710	1482	760	1677	808	1876	855	2081	900	2290	944	2504	986	2723	1028	2946	1068	3173	1108	3403	
4500	723	1577	773	1775	820	1978	866	2187	910	2400	954	2618	996	2840	1037	3067	1076	3297	-	-	
4600	737	1675	785	1877	832	2085	877	2297	921	2514	963	2736	1005	2962	1045	3192	1085	3426	-	-	
4700	751	1778	798	1984	844	2195	889	2412	932	2633	974	2858	1014	3088	1054	3322	-	-	-	-	
4800	765	1885	812	2095	856	2310	900	2531	942	2756	984	2985	1024	3219	-	-	-	-	-	-	
4900	779	1996	825	2210	869	2430	912	2654	953	2883	994	3116	1034	3353	-	-	-	-	-	-	
5000	793	2112	838	2330	881	2554	923	2782	965	3014	1005	3251	-	-	-	-	-	-	-	-	

LEGEND

Watts = Input Watts to motor.

* Motor drive range: 860 to 1080 rpm. All other rpms require a field-supplied drive.

Maximum continuous bhp is 3.70.

PHE Series PERFORMANCE DATA (CONT.)

Evaporator-Fan Motor Efficiency	
Unit PHE	Motor Efficiency (%)
	Standard
072	84
090	80
102	80
120	85

All indoor-fan motors 5 hp and larger meet the minimum efficiency requirements as established by the Energy Policy Act of 1992 (EPACT) effective October 24, 1997.

EVAPORATOR-FAN MOTOR PERFORMANCE

Unit PHE	Evaporator-Fan Motor	Unit Voltage	Max. Acceptable Continuous BHP*	Max. Acceptable Operating Watts	Max. AMP Draw
072	Standard	208/230	2.40	2120	6.0
		460			3.0
090	Standard	208/230	2.90	2615	8.6
		460			3.9
102	Standard	208/230	2.90	2615	8.6
		460			3.9
120	Standard	208/230	3.70	3313	11.7
		460			5.5

LEGEND

BHP = Brake Horsepower

* Extensive motor and electrical testing on these units ensures that the full horsepower range of the motors can be utilized with

confidence. Using your fan motors up to the horsepower ratings shown in this table will not result in nuisance tripping or premaure motor failure. Unit Warranty will not be affected.

FAN RPM MOTOR PULLEY SETTINGS

Unit PHE	MOTOR PULLEY TURNS OPEN										
	0	1/2	1	1-1/2	2	2-1/2	3	3-1/2	4	4-1/2	5
072	1585	1538	1492	1445	1399	1352	1305	1259	1212	1166	1119
090	950	930	905	885	865	840	820	795	775	750	730
102	1085	1061	1036	1012	987	963	938	914	889	865	840
120	1080	1060	1035	1015	990	970	950	925	905	880	860

* Approximate fan rpm shown.

1 - Indicates standard motor and drive package.

2 - Indicates optional high static motor and drive package.

TYPICAL INSTALLATIONS

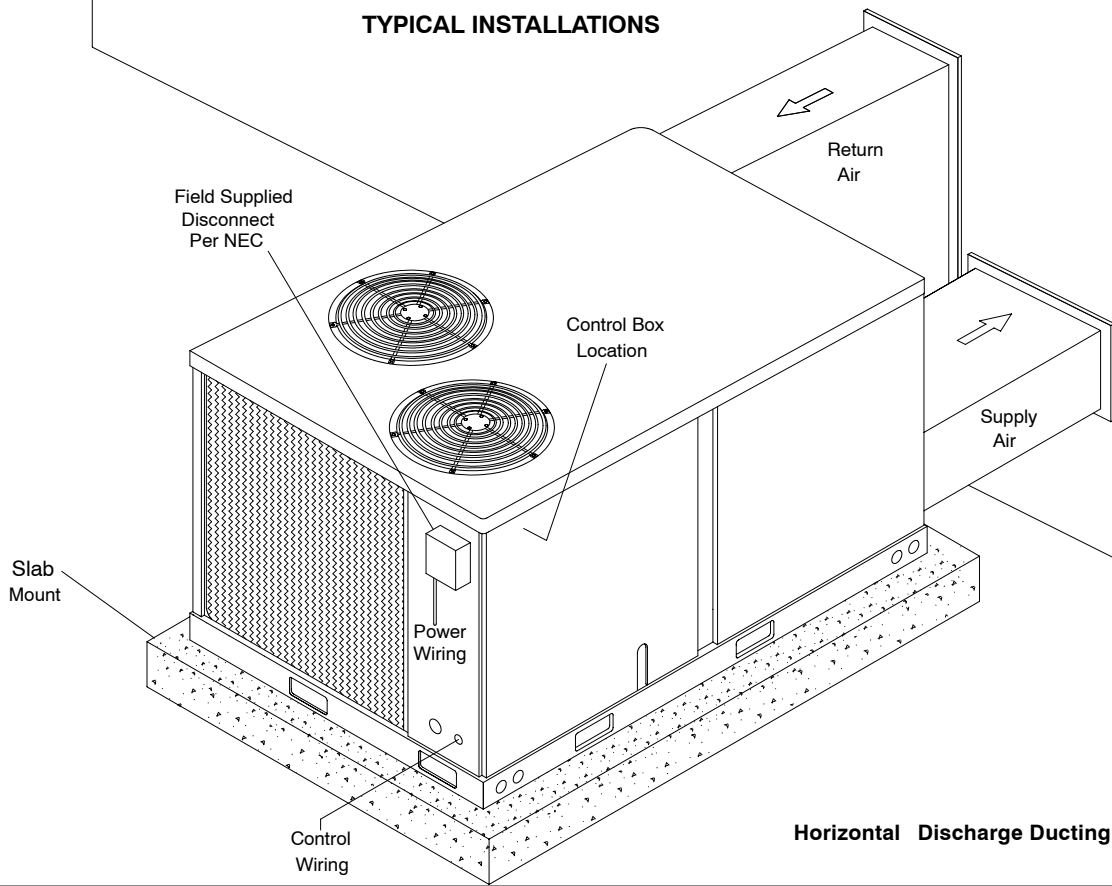

Horizontal Discharge Ducting

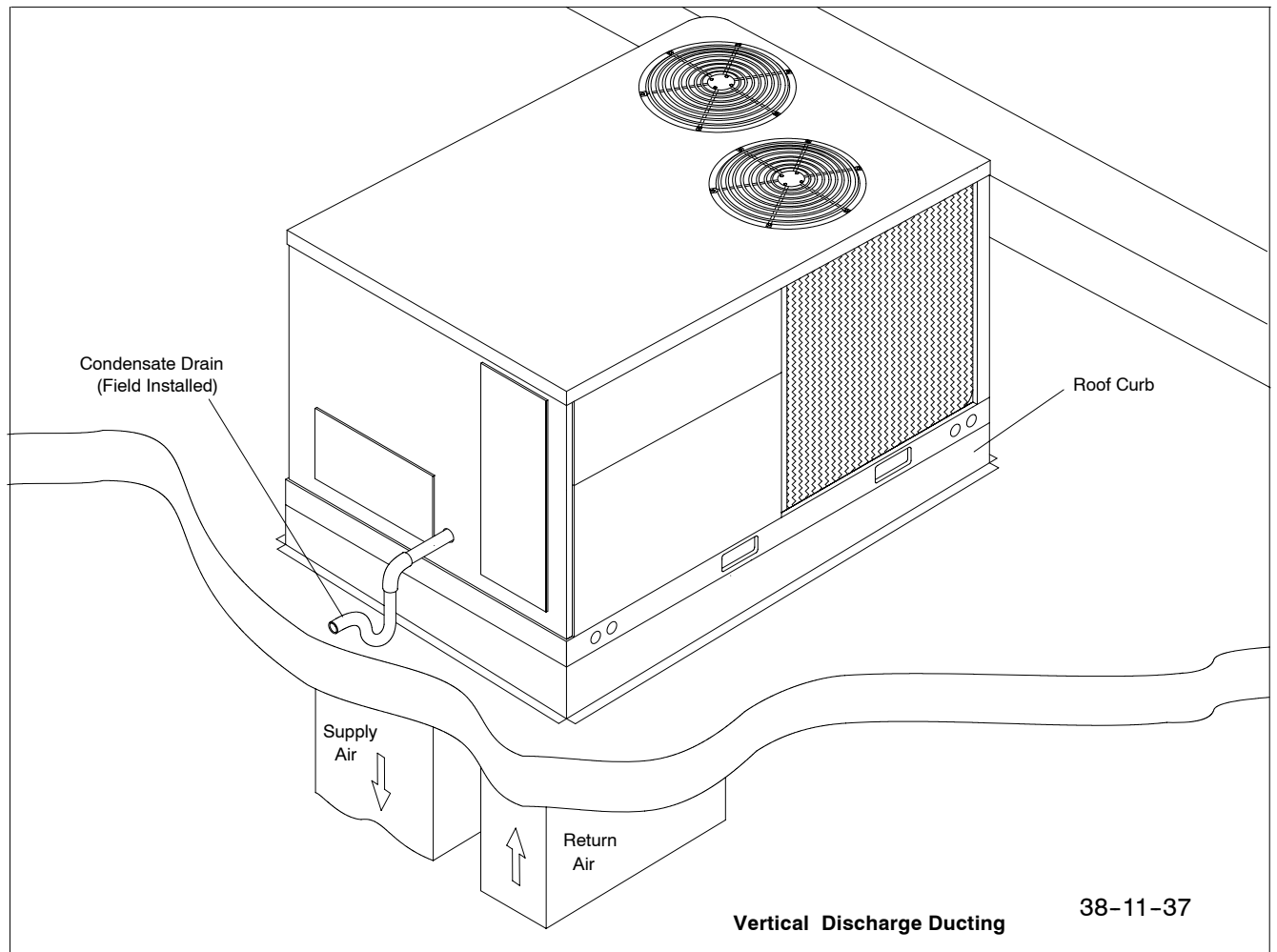

Vertical Discharge Ducting

38-11-37

ACCESSORIES - PHE072

ROOF CURBS

Description	Model Number	Where Used
8" High *	AXB035CLA	072
14" High *	AXB035CMA	072
24" High *	AXB035CHA	072

CURB ADAPTOR

Description	Model Number	Where Used *
Curb Adaptor	AXB035CAA	072
Curb Adaptor With Duct	AXB035CBA	072

* Used with AXB030 curbs.

Roof Opening
35" Long
40" Wide

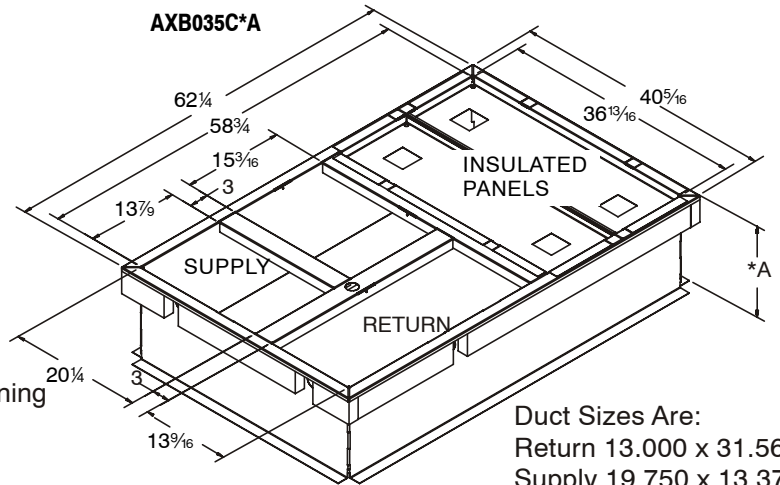

Duct Sizes Are:
Return 13.000 x 31.563
Supply 19.750 x 13.375

ECONOMIZER - DOWNFLOW

Description	Model Number	Where Used
Fully Modulating	AXB035EMA	072
Three Position	AXB035EPA	072

AXB035E*A

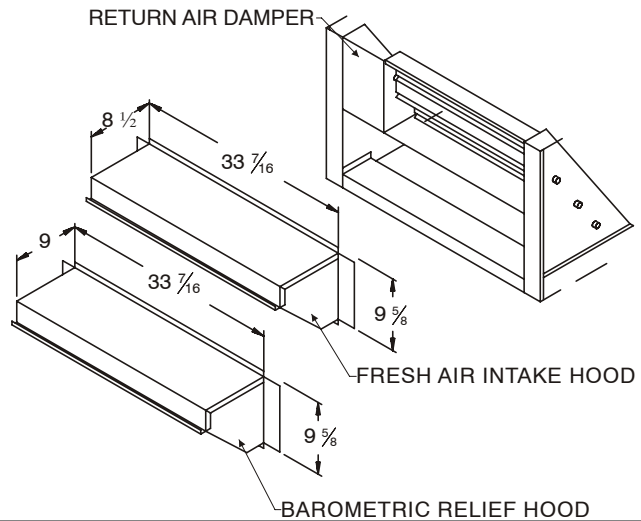

ECONOMIZER - HORIZONTAL

Description	Model Number	Where Used
Fully Modulating	AXB035HEA	072
Three Position	AXB035HPA	072

AXB035H*A

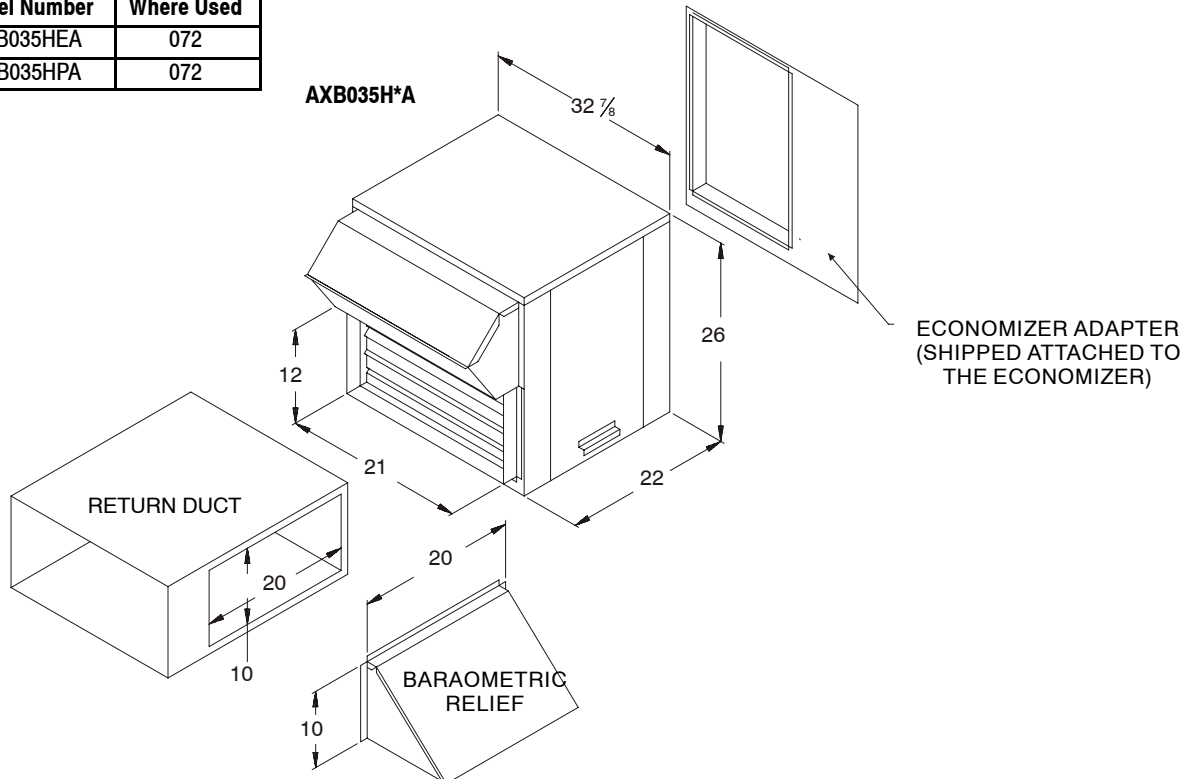

ACCESSORIES: PHE072 (CONT.)

FRESH AIR DAMPER

Description	Model Number	Where Used
Manual	AXB035FAA	072
Motorized	AXB035FMA	072

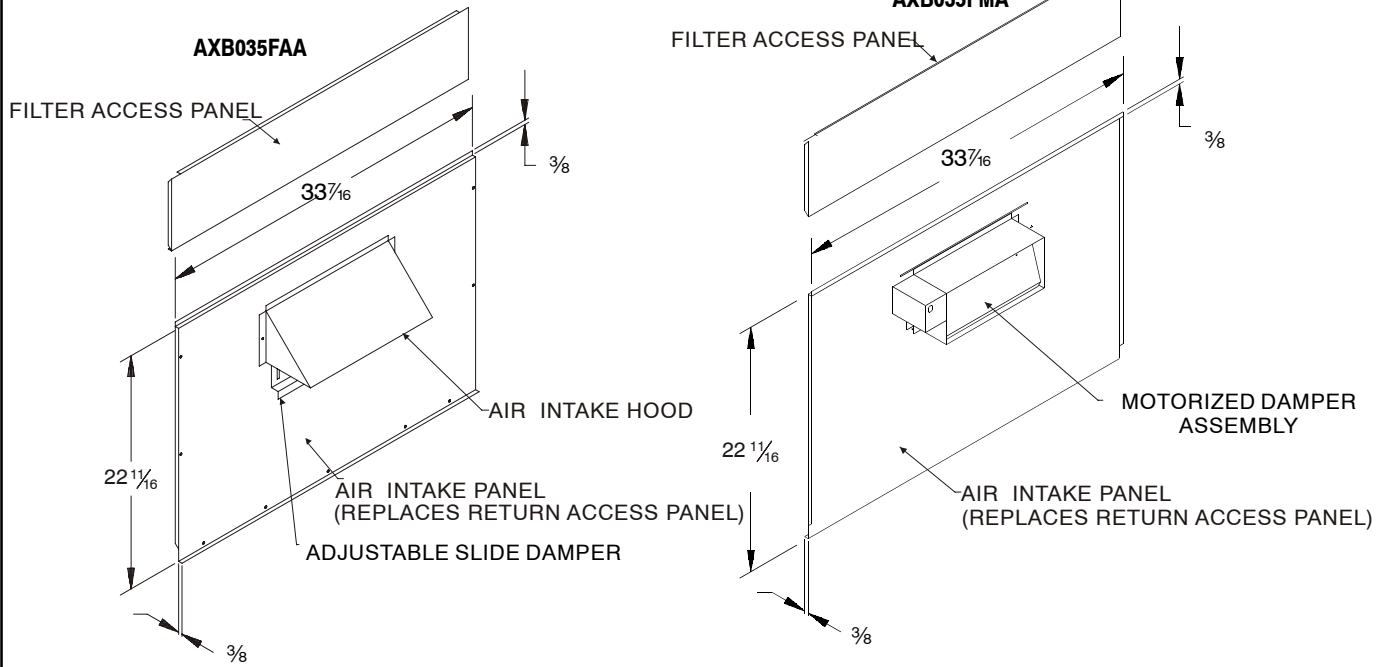

COIL PROTECTION

Description	Model Number	Where Used
Coil Guard	AXB035CGA	072
Hail Guard	AXB035HGA	072

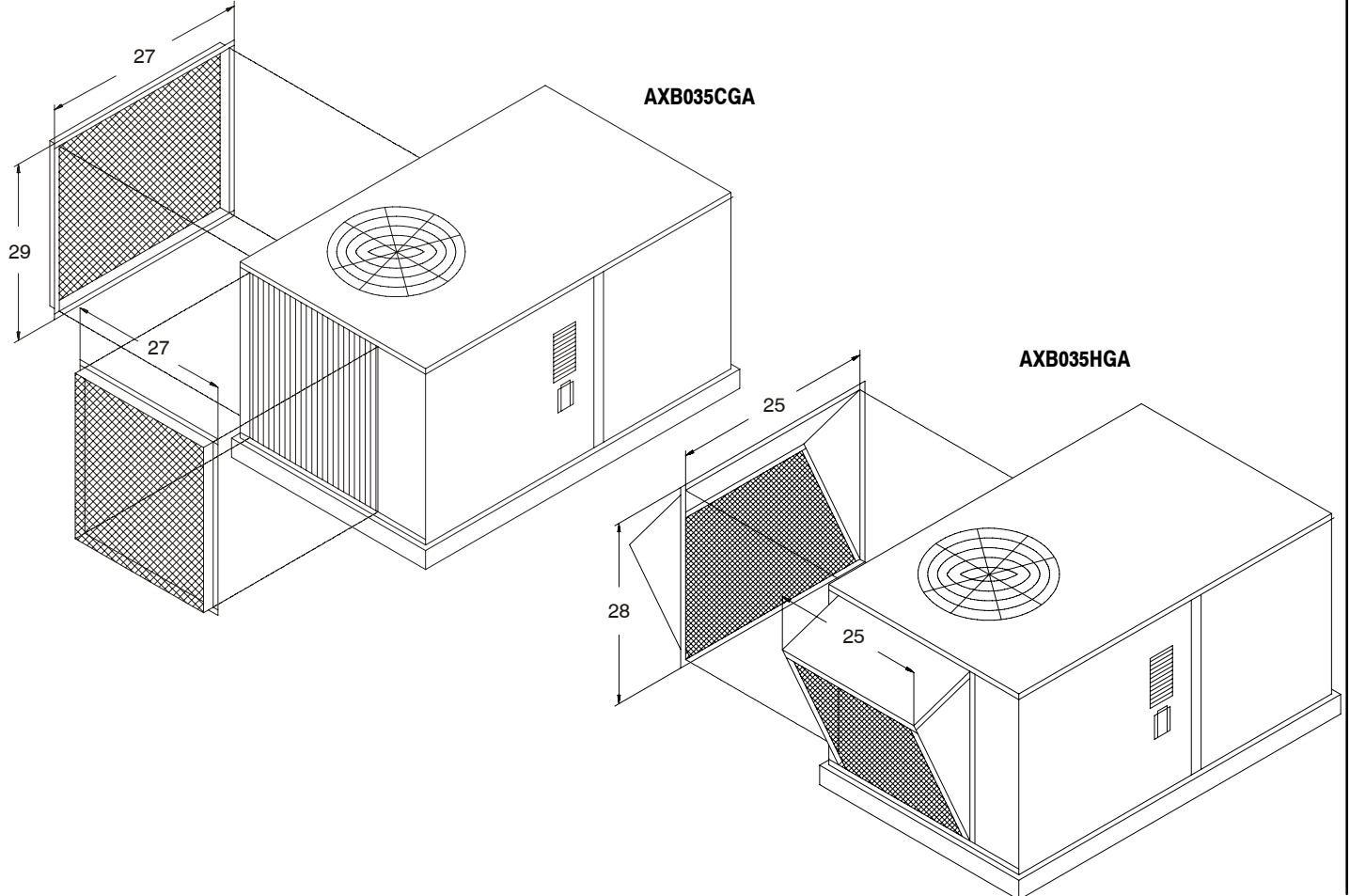

ACCESSORIES: PHE072 (CONT.)

CONCENTRIC DUCT KIT

Description	Model Number	Where Used
20" Round.	AXB035CTA	072

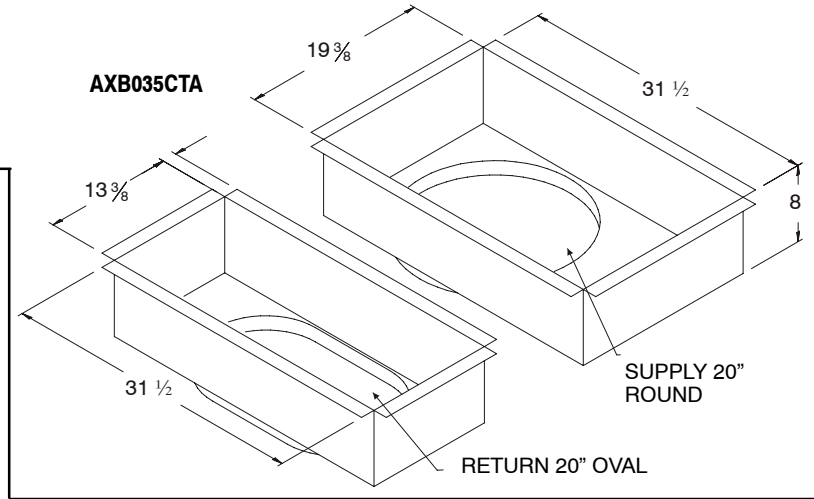

PERFORMANCE DATA ON NEXT PAGE

CONCENTRIC DIFFUSER

Description	Model Number	Used With
Flush Mount	AXB030CFA	072
Flush Mount	AXB040CFA	072
Step Down	AXB030CSA	072
Step Down	AXB040CSA	072

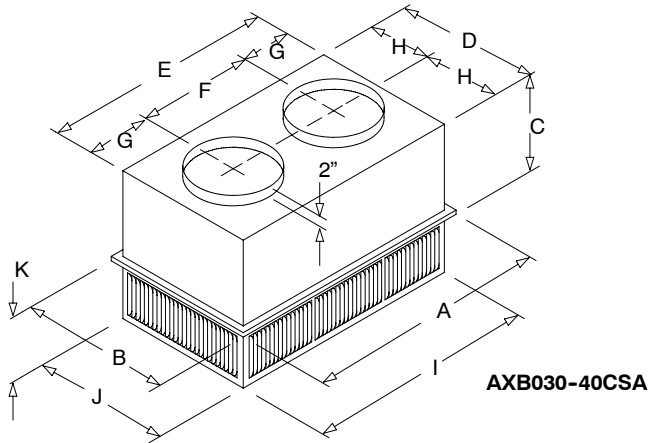

CONCENTRIC DIFFUSER (Step Down)

Model Number	A	B	C	D	E	F	G	H	I	J	K	Duct Size
AXB030CSA	47-5/8	23-5/8	11-3/8	21-1/2	45-1/2	22-1/2	11-1/2	10-3/4	45-1/2	21-1/2	7-1/8	18" RD
AXB040CSA	47-5/8	29-5/8	14-3/8	27-1/2	45-1/2	22-1/2	11-1/2	13-3/4	45-1/2	27-1/2	8-1/8	20" RD

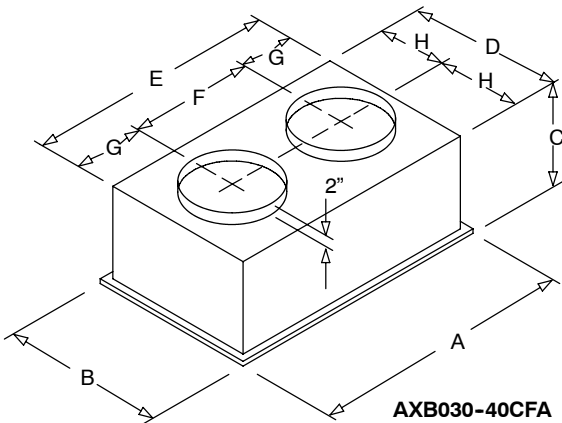

CONCENTRIC DIFFUSER (Flush Mount)

Model Number	A	B	C	D	E	F	G	H	Duct Size
AXB030CFA	47-5/8	23-5/8	13-1/2	21	45	22-1/2	11-1/4	10-1/2	18" RD
AXB040CFA	47-5/8	29-5/8	16-5/8	27	45	22-1/2	11-1/4	13-1/2	20" RD

ACCESSORIES: PHE072 (CONT.)

CSA SERIES STEP-DOWN PERFORMANCE

Part No. AXB	CFM	Static Pressure In. WC	Throw Feet	Neck / Jet Velocity FPM	db Sound Levels
030CSA	1200	.17	11-18	421	20
	1400	.20	12-19	491	20
	1600	.24	12-20	561	20
	1800	.30	13-21	632	20
	2000	.36	14-23	702	20
	2200	.40	16-25	772	20
040CSA	2600	.17	24-29	669	20
	2800	.20	25-30	720	25
	3000	.25	27-33	772	25
	3200	.31	28-35	823	25
	3400	.37	30-37	874	30

CFA SERIES FLUSH MOUNT PERFORMANCE

Part No. AXB	CFM	Static Pressure In. WC	Throw Feet	Neck Velocity FPM	Jet Velocity FPM	db Sound Level
030CFA	1000	.14	15-20	391	694	20
	1200	.17	16-22	469	833	25
	1400	.20	17-24	547	972	30
	1600	.24	18-25	625	1111	30
	1800	.30	20-28	703	1250	35
	2000	.36	21-29	781	1389	40
	2200	.40	22-30	859	1528	40
	040CFA	2600	.17	19-24	663	1294
2800		.20	20-28	714	1393	35
3000		.25	21-29	765	1492	35
3200		.31	22-29	816	1592	40
3400		.37	22-30	867	1692	40

CSA/CFA NOTES:

1. All data is based on the Air Diffusion Council guidelines.
2. Throw data is based on Terminal Velocities of 75 FPM using isothermal air.
3. Throw is based on diffuser blades being directed in a straight pattern.
4. Actual sound levels are less than those shown.
5. Minimum height 9' above floor.

LOW AMBIENT KIT

Model Number	Used With
AXB035LAA	072

THRU-THE-BASE POWER KIT

Model Number	Used With
AXB035PKA	072

ACCESSORIES: PHE072 (CONT.)

POWER EXHAUST

Description	Model Number	Where Used
208/230 Volt	AXB035PEH	072
460 Volt	AXB035PEL	072
575 Volt	AXB035PES	072

POWER EXHAUST PERFORMANCE DATA

Model	Volt/Phase/ Hertz	Motor			Unit									
		Qty	HP	RPM	Cir. Qty	LRA	FLA	MCA	Fuse Size	@0.0		@0.3		
										CFM	RPM	CFM	RPM	
AXB035PEH	208-230/1/60	1	1	1725	1	10.2	4.3	5.4	10	2400	1725	2100	1725	
AXB035PEL	460/1/60	1	1	1625	1	4.1	1.7	2.2	4	2300	625	2000	1625	
AXB035PES	575/1/60	1	1	1625	1	4.1	1.7	2.2	4	2300	1625	2000	1625	

NOTE: Power exhaust is wired single phase, drop third leg when installing.

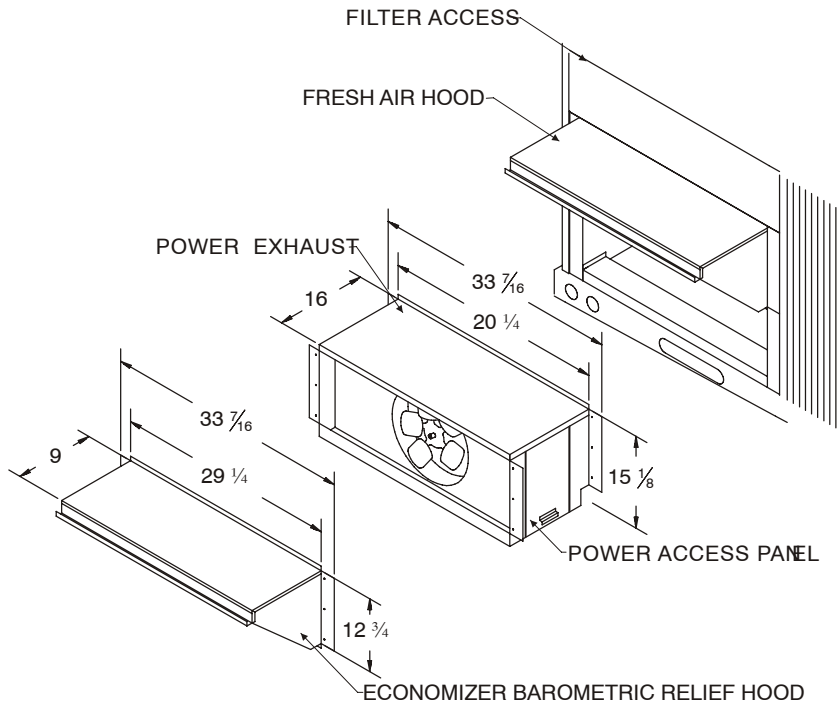

ACCESSORIES - PHE090 - 120

ROOF CURBS

Description	Model Number	Where Used
8" High *	AXB045CLA	090, 102, 120
14" High *	AXB045CMA	090, 102, 120
24" High *	AXB045CHA	090, 102, 120

* A Dimension

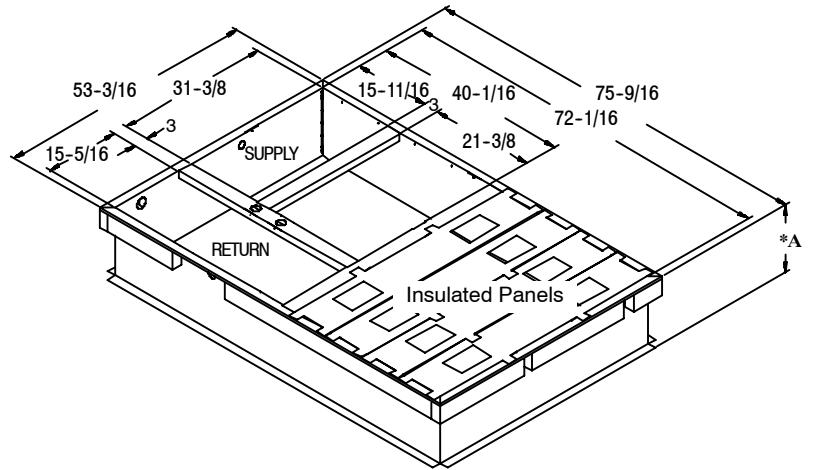

ECONOMIZER - DOWNFLOW

Description	Model Number	A Dimension	B Dimension	Where Used
Fully Modulating	AXB145EMA	13-3/4"	12-3/4"	090, 102
	AXB245EMA	16-1/2"	17-3/4"	120
Three Position	AXB145EPA	13-3/4"	12-3/4"	090, 102
	AXB245EPA	16-1/2"	17-3/4"	120

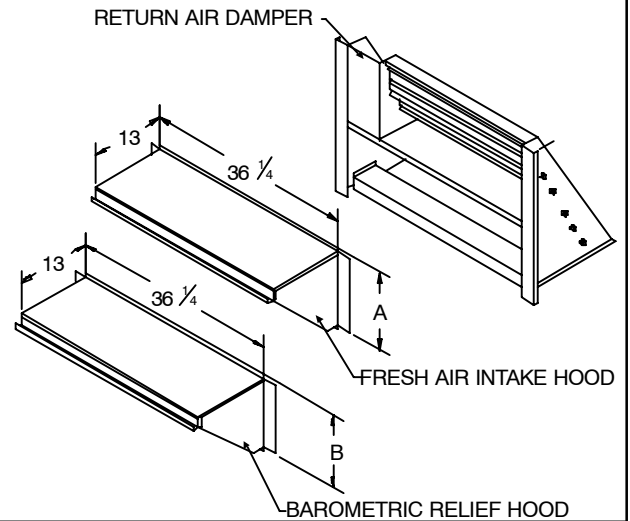

ECONOMIZER - HORIZONTAL

Description	Model Number	Where Used
Fully Modulating	AXB145HEA	090, 102
	AXB245HEA	120
Three Position	AXB145HPA	090, 102
	AXB245HPA	120

ECONOMIZER ADAPTOR
The height of the economizer adaptor opening is the only difference between the AXB145 & AXB245.
(SHIPPED ATTACHED TO THE ECONOMIZER)

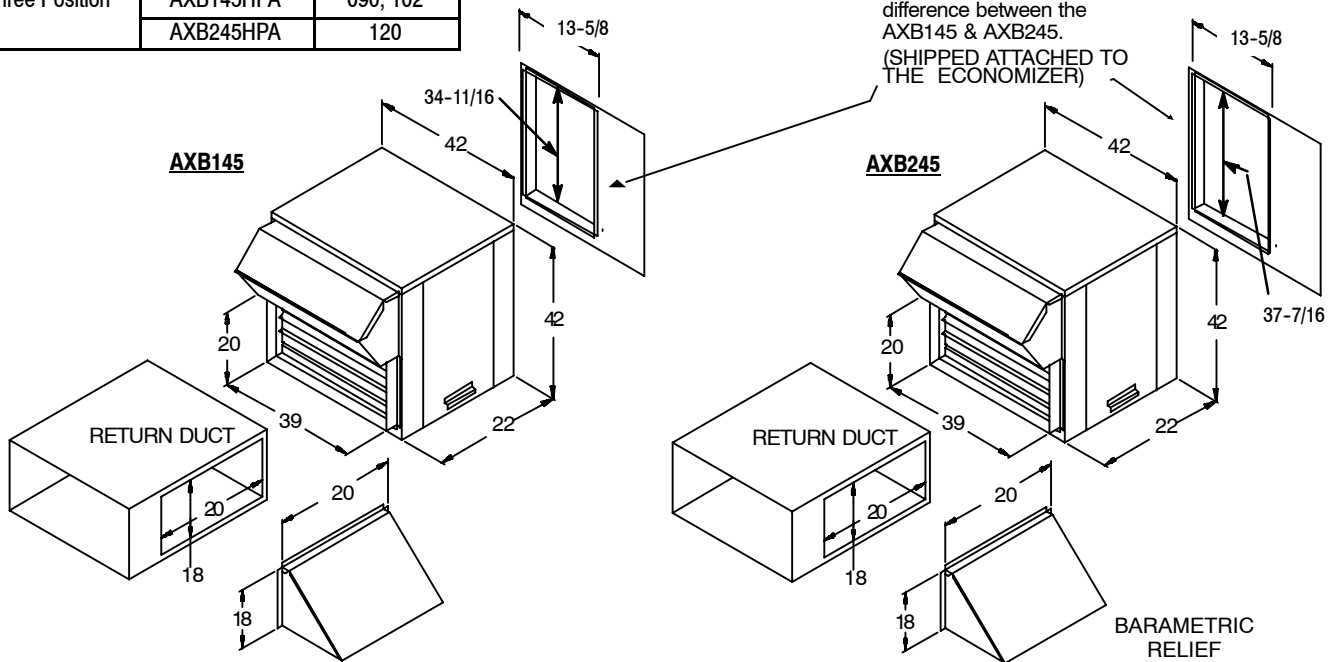

ACCESSORIES - PHE090 - 120 (CONT.)

FRESH AIR DAMPER			
Description	Model Number	A Dimension	Where Used
Manual	AXB145FAA	27-15/16	090, 102
	AXB245FAA	32-1/2	120
Motorized	AXB145FMA	27-15/16	090, 102
	AXB245FMA	32-1/2	120

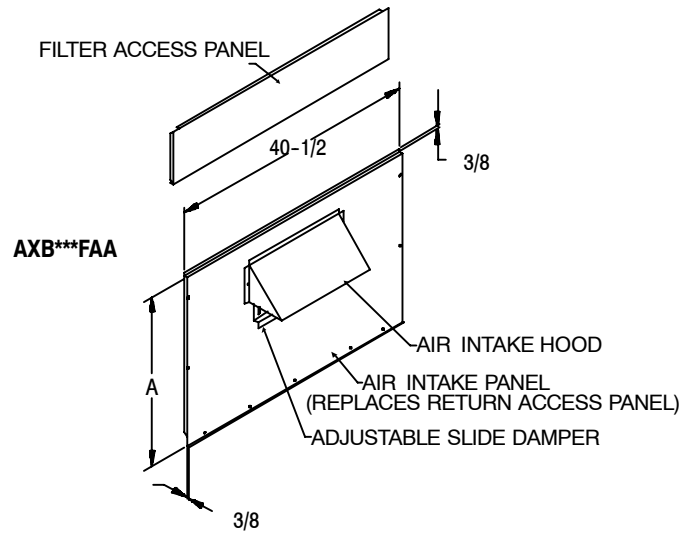
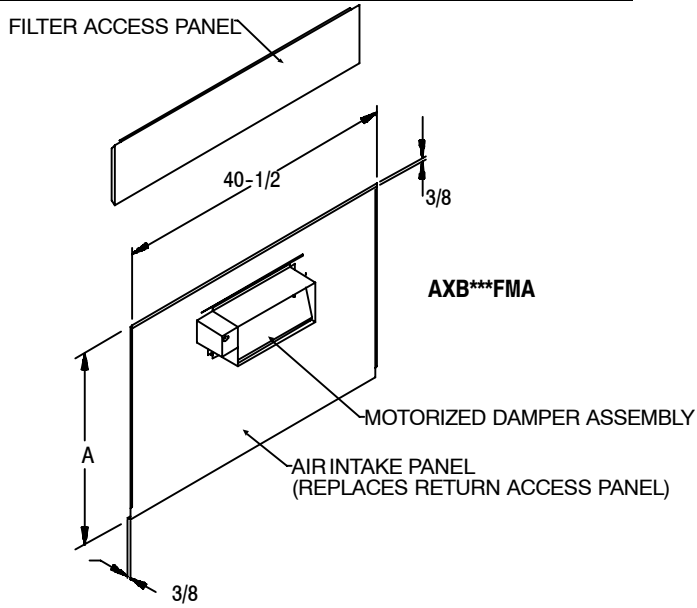

COIL PROTECTION			DIMENSIONS	
Description	Model Number	Where Used	A	B
Coil Guard	AXB145CGA	090, 102	44	37
	AXB245CGA	120	45-3/8	45
Hail Guard	AXB145HGA	090, 102	42	36
	AXB245HGA	120	43-3/8	44

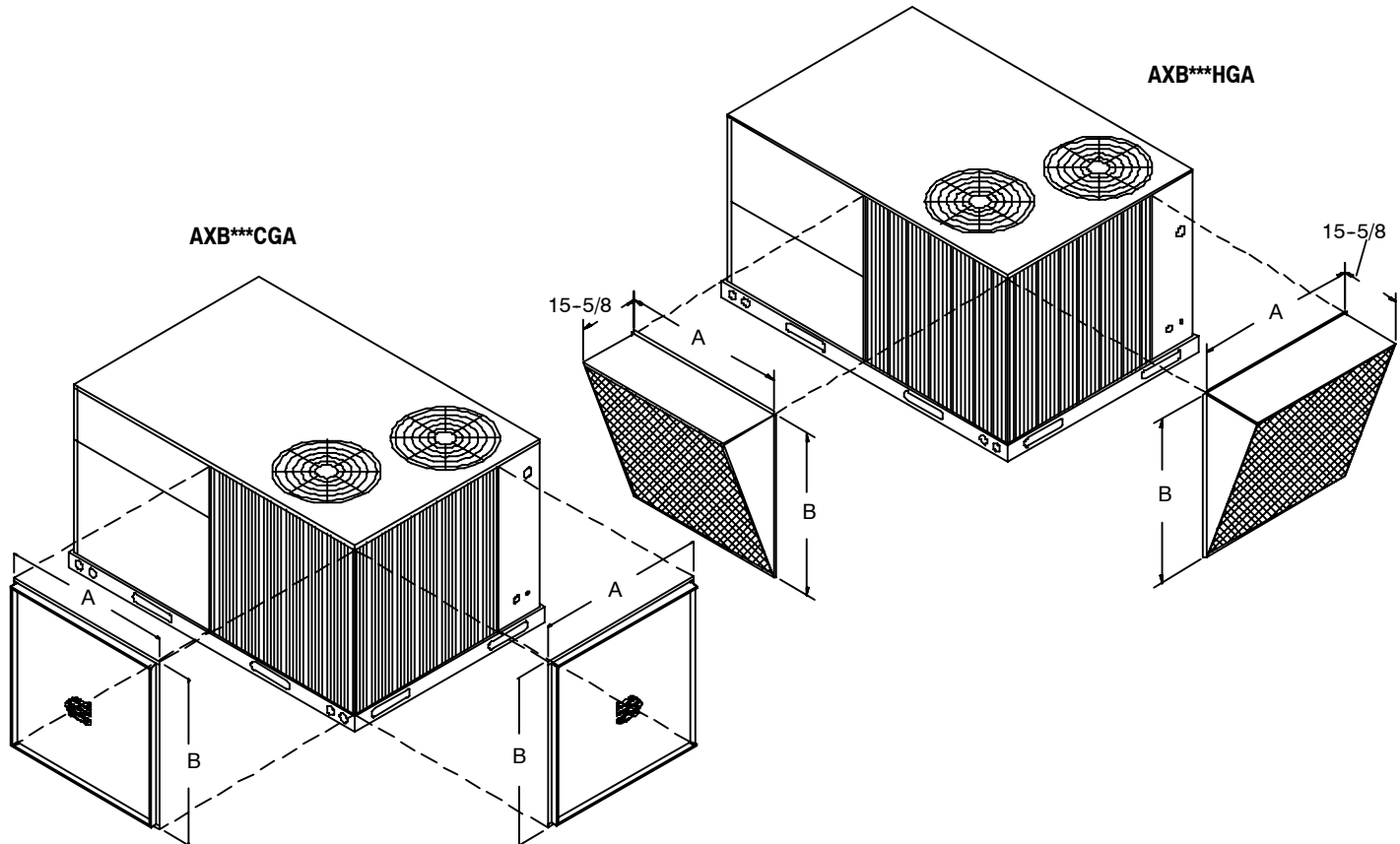

ACCESSORIES - PHE090 - 120 (CONT.)

CONCENTRIC DUCT KIT

Description	Model Number	Where Used
20" Round	AXB445CTA	090, 102
18" x 28" Rect.	AXB545CTA	120

AXB445CTA SHOWN

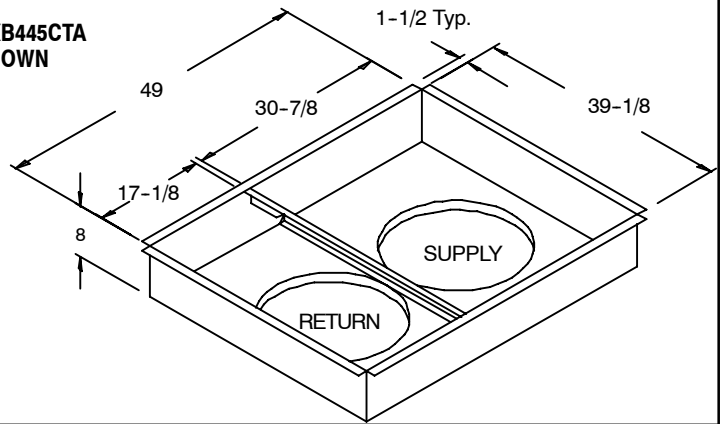

PERFORMANCE DATA ON NEXT PAGE

CONCENTRIC DIFFUSER

Description	Model Number	Used With
Flush Mount	AXB040CFA	AXB445CTA
Flush Mount	AXB045CFA	AXB545CTA
Flush Mount	AXB050CFA	AXB645CTA
Step Down	AXB040CSA	AXB445CTA
Step Down	AXB045CSA	AXB545CTA
Step Down	AXB050CSA	AXB645CTA

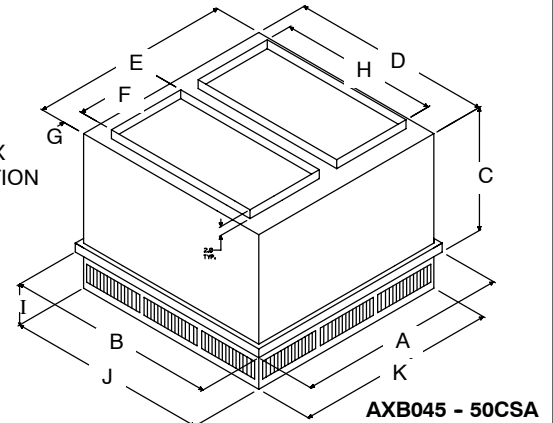
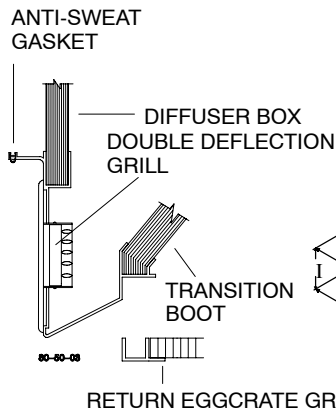
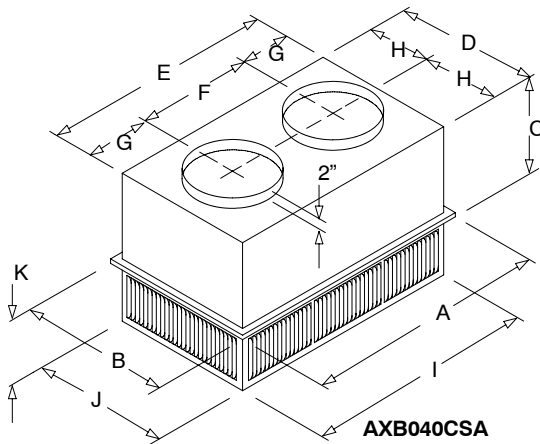

CONCENTRIC DIFFUSER (Step Down)

Model Number	A	B	C	D	E	F	G	H	I	J	K	Duct Size
AXB040CSA	47-5/8	29-3/8	14-3/8	27-1/2	45-1/2	22-1/2	11-1/2	13-3/4	45-1/2	27-1/2	8-1/8	20" RD
AXB045CSA	47-5/8	35-5/8	20-5/8	33-1/2	45-1/2	18	2-1/2	28	9-1/8	33-1/2	45-1/2	18 x 28
AXB050CSA	47-5/8	41-5/8	25-7/8	45-1/2	45-1/2	18	2-1/2	32	9-1/8	39-1/2	45-1/2	18 x 32

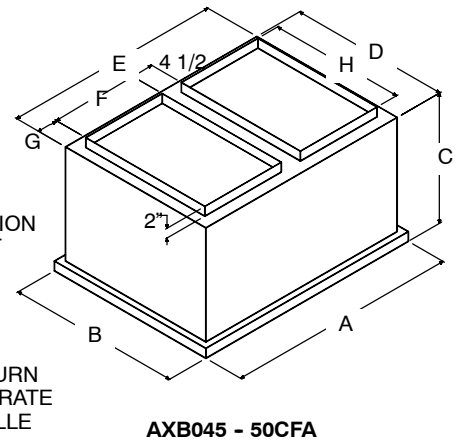
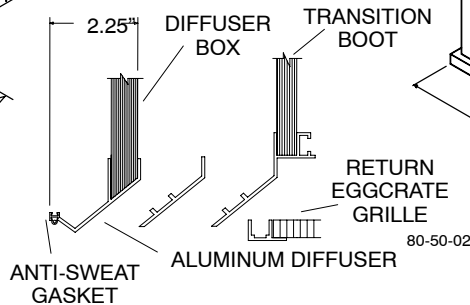
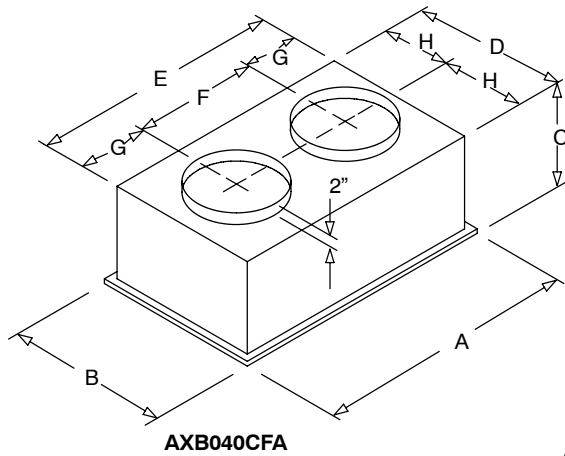

CONCENTRIC DIFFUSER (Flush Mount)

Model Number	A	B	C	D	E	F	G	H	Duct Size
AXB040CFA	47-5/8	29-5/8	16-5/8	27	45	22-1/2	11-1/4	13-1/2	20" RD
AXB045CFA	47-5/8	35-5/8	21-3/4	33	45	18	2-1/4	28	18 x 28
AXB050CFA	47-5/8	41-5/8	29-1/4	39	45	18	2-1/4	32	18 x 32

ACCESSORIES - PHE090 - 120 (CONT.)

CSA SERIES STEP-DOWN PERFORMANCE					
Part No. AXB	CFM	Static Pressure In. WC	Throw Feet	Neck / Jet Velocity FPM	db Sound Levels
040CSA	2600	.17	24-29	669	20
	2800	.20	25-30	720	25
	3000	.25	27-33	772	25
	3200	.31	28-35	823	25
	3400	.37	30-37	874	30
045CSA	3600	.17	25-33	851	30
	3800	.18	27-35	898	30
	4000	.21	29-37	946	30
	4200	.24	32-40	993	30
	4400	.27	34-42	1040	30
050CSA	4400	.29	25-30	733	30
	4600	.31	26-31	767	30
	4800	.32	27-32	800	30
	5000	.34	28-33	833	30
	5200	.36	28-34	867	30
	5400	.39	29-35	900	30

CFA SERIES FLUSH MOUNT PERFORMANCE						
Part No. AXB	CFM	Static Pressure In. WC	Throw Feet	Neck Velocity FPM	Jet Velocity FPM	db Sound Level
040CFA	2600	.17	19-24	663	1294	30
	2800	.20	20-28	714	1393	35
	3000	.25	21-29	765	1492	35
	3200	.31	22-29	816	1592	40
	3400	.37	22-30	867	1692	40
045CFA	3600	.17	22-29	844	1646	35
	3800	.18	22-30	891	1737	40
	4000	.21	24-33	938	1829	40
	4200	.24	26-35	985	1920	40
	4400	.27	28-37	1032	2011	40
050CFA	4600	.31	25-34	922	1795	40
	4800	.32	26-35	962	1873	40
	5000	.34	27-36	1002	1951	40
	5200	.36	30-39	1043	2029	45
	5400	.39	32-41	1083	2107	45

CSA/CFA NOTES:

1. All data is based on the Air Diffusion Council guidelines.
2. Throw data is based on Terminal Velocities of 75 FPM using isothermal air.
3. Throw is based on diffuser blades being directed in a straight pattern.
4. Actual sound levels are less than those shown.
5. Minimum height 9' above floor.

LOW AMBIENT KIT	
Model Number	Used With
AXB045LAA	090 - 120
THRU-THE-BASE POWER KIT	
Model Number	Used With
AXB045PKA	090 - 120
With 1-1/4" Power and 3/4" Gas Connections.	

ACCESSORIES - PHE090 - 120 (CONT.)

POWER EXHAUST

Description	Model Number	Where Used
208/230 Volt	AXB145PEH	090, 102
460 Volt	AXB145PEL	090, 102
575 Volt	AXB145PES	090, 102
208/230 Volt	AXB245PEH	120
460 Volt	AXB245PEL	120
575 Volt	AXB245PES	120

POWER EXHAUST PERFORMANCE DATA

Model	Volt/Phase/ Hertz	Motor				Unit									
		Qty	HP	RPM	Cir. Qty	LRA	FLA	MCA	Fuse Size	@0.0		@0.1	@0.3		
										CFM	RPM	CFM	CFM	RPM	
AXB145PEH	208-230/1/60	1	1/2	1725	1	10.2	4.3	5.4	8	2400	1725	N/A	2100	1725	
AXB145PEL	460/1/60	1	1/2	1625	1	4.1	1.7	2.2	5	2300	1625	N/A	2000	1625	
AXB145PES	575/1/60	1	1/2	1625	1	4.1	1.7	2.2	5	2300	1625	N/A	2000	1625	
AXB245PEH	208-230/1/60	1	3/4	1075	1	24.9	5.0	6.3	10	N/A	N/A	4800	N/A	N/A	
AXB245PEL	460/1/60	1	3/4	1075	1	N/A	2.2	2.8	5	N/A	N/A	4800	N/A	N/A	
AXB245PES	575/1/60	1	3/4	1050	1	N/A	1.5	1.9	4	N/A	N/A	4800	N/A	N/A	

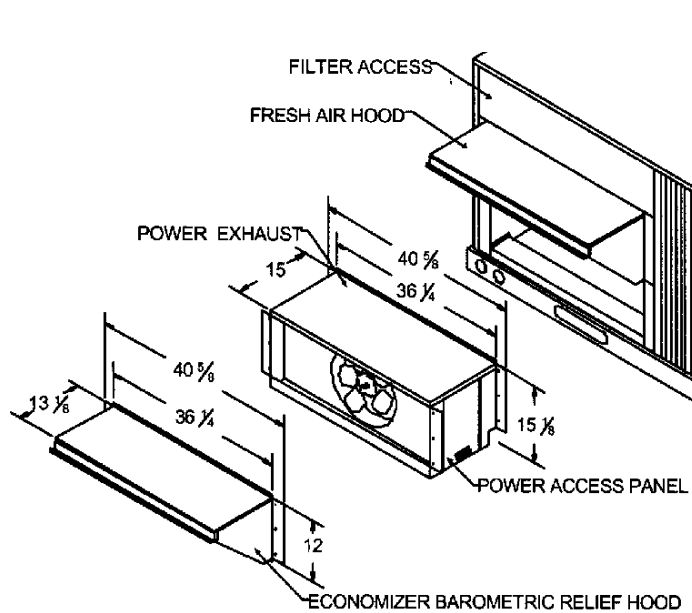

POWER EXHAUST DOWNFLOW, MODEL AXB145***

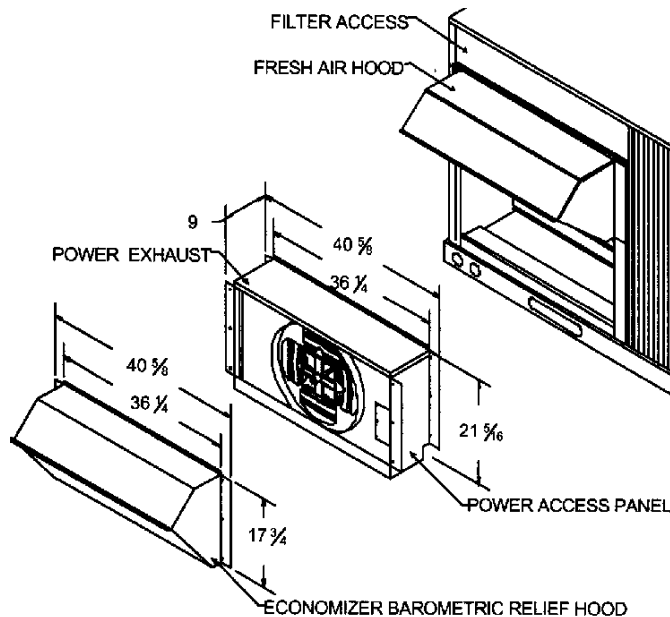

POWER EXHAUST DOWNFLOW, MODEL AXB245***

ACCESSORIES (CONT.)

PHE SERIES ELECTRICAL DATA - ELECTRIC HEAT ACCESSORY

Unit	Voltage	Qty	Model Number	Evap. Fan Motor FLA	Cond. Fan Motor FLA	Electric Heater *		Power Supply		Disconnect Size **		Single Point Kit Required
						Nominal kW	FLA	MCA	MOCP ***	FLA	LRA	
PHE072	208-3-60	1	AES007EHA	5.8	1.4 each	4.9	13.6	49.8	50	47	214	-
		1	AES009EHA			7.9	21.9	60.2	70	57	222	AXB002SPA
		1	AES015EHA			12	33.3	74.5	80	70	233	AXB002SPA
		1 ea.	AES009EHA, AES009EHA			15.8	43.9	87.7	90	82	244	AXB003SPA
		1 ea.	AES009EHA, AES015EHA			19.9	55.2	101.8	110	95	255	AXB003SPA
PHE072	230-3-60	1	AES007EHA	5.8	1.4 each	6.5	15.6	52.3	60	50	216	-
		1	AES009EHA			10.5	25.3	64.5	70	61	225	AXB002SPA
		1	AES015EHA			16	38.5	81	90	76	239	AXB002SPA
		1 ea.	AES009EHA, AES009EHA			21	50.5	96	100	90	251	AXB003SPA
		1 ea.	AES009EHA, AES015EHA			26.5	63.8	112.6	125	105	264	AXB003SPA
PHE072	460-3-60	1	AES006ELA	2.6	.7 each	6	7.2	24.2	25	23	99	-
		1	AES011ELA			11.5	13.8	32.5	35	31	106	-
		1	AES013ELA			14	16.8	36.2	40	34	109	-
		1 ea.	AES011ELA, AES011ELA			23	27.7	49.8	50	47	120	-
		1 ea.	AES011ELA, AES013ELA			25.5	30.7	53.6	60	50	123	-
PHE090	208-3-60	1	AES010EHA	7.5	1.4 each	7.8	21.7	65.3	70	65	264	AXB007SPA
		1	AES016EHA			12.0	33.4	79.8	80	79	275	AXB007SPA
		1	AES024EHA			18.6	51.7	102.7	110	100	294	AXB009SPA
		1	AES032EHA			24.0	66.7	121.5	125	117	309	AXB009SPA
		1 ea.	AES032EHA, AES010EHA			31.9	88.4	148.6	150	142	330	AXB013SPA
PHE090	230-3-60	1	AES010EHA	7.5	1.4 each	10.4	25.0	69.5	70	69	267	AXB007SPA
		1	AES016EHA			16.0	38.5	86.3	90	85	281	AXB007SPA
		1	AES024EHA			24.8	59.7	112.8	125 #	109	302	AXB009SPA
		1	AES032EHA			32.0	77.0	134.5	150 #	129	319	AXB009SPA
		1 ea.	AES032EHA, AES010EHA			42.4	102.0	165.7	175 #	158	344	AXB013SPA
PHE090	460-3-60	1	AES014ELA	3.4	.7 each	14.0	16.7	40.1	45	39	138	AXB006SPA
		1	AES016ELA			16.5	19.8	44.0	45	43	141	AXB006SPA
		1	AES027ELA			27.8	33.4	61.0	70	58	155	AXB008SPA
		1	AES033ELA			33.0	39.7	68.8	70	66	161	AXB008SPA
		1 ea.	AES014ELA, AES027ELA			41.7	50.2	82.0	90 #	78	171	AXB010SPA
PHE102	208-3-60	1	AES010EHA	7.5	1.4 each	7.8	21.7	68.4	70	68	298	AXB0012SPA
		1	AES016EHA			12.0	33.4	82.9	80	82	309	AXB012SPA
		1	AES024EHA			18.6	51.7	105.8	110	103	328	AXB015SPA
		1	AES032EHA			24.0	66.7	124.5	125	120	343	AXB015SPA
		1 ea.	AES032EHA, AES010EHA			31.9	88.4	151.7	150	145	364	AXB017SPA
PHE102	230-3-60	1	AES010EHA	7.5	1.4 each	10.4	25.0	72.5	70	72	301	AXB012SPA
		1	AES016EHA			16.0	38.5	89.4	90	88	315	AXB012SPA
		1	AES024EHA			24.8	59.7	115.9	125 #	112	336	AXB015SPA
		1	AES032EHA			32.0	77.0	137.5	150 #	132	353	AXB015SPA
		1 ea.	AES032EHA, AES010EHA			42.4	102.0	168.8	175 #	161	378	AXB017SPA
PHE102	460-3-60	1	AES014ELA	3.4	.7 each	14.0	16.7	43.2	45	43	160	AXB011SPA
		1	AES016ELA			16.5	19.8	47	45	46	163	AXB011SPA
		1	AES027ELA			27.8	33.4	64	70	62	177	AXB014SPA
		1	AES033ELA			33.0	39.7	71.9	70	69	183	AXB014SPA
		1 ea.	AES014ELA, AES027ELA			41.7	50.2	85	90 #	81	193	AXB016SPA

NOTE: See legend and notes for accessories.

PHE SERIES ELECTRICAL DATA - ELECTRIC HEAT ACCESSORY (CONT.)

Unit	Voltage	Qty	Model Number	Evap. Fan Motor FLA	Cond. Fan Motor FLA	Electric Heater *		Power Supply		Disconnect Size **		Single Point Kit Required
						Nominal kW	FLA	MCA	MOCP ***	FLA	LRA	
PHE120	208-3-60	1	AES010EHA	10.6	1.4 each	7.8	21.7	84.0	90	85	358	AXB012SPA
		1	AES016EHA			12.0	33.4	98.5	100	98	370	AXB012SPA
		1	AES032EHA			24.0	66.7	140.1	150	136	403	AXB015SPA
		1 ea.	AES032EHA, AES010EHA			31.9	88.4	167.2	175	161	425	AXB015SPA
		1 ea.	AES032EHA, AES016EHA			37.5	104.2	187.3	200	180	441	AXB017SPA
PHE120	230-3-60	1	AES010EHA	10.6	1.4 each	10.4	25.0	88.1	90	89	362	AXB012SPA
		1	AES016EHA			16.0	38.5	105.0	110	104	375	AXB012SPA
		1	AES032EHA			32.0	77.0	153.1	175	148	414	AXB015SPA
		1 ea.	AES032EHA, AES010EHA			42.4	102.0	184.3	200	177	439	AXB017SPA
		1 ea.	AES032EHA, AES016EHA			50.0	120.3	177.1	200	198	457	AXB017SPA
PHE120	460-3-60	1	AES016ELA	4.8	.7 each	16.5	19.8	53.3	60	53	189	AXB011SPA
		1	AES027ELA			27.8	33.4	70.5	80	69	203	AXB014SPA
		1	AES033ELA			33.0	39.7	78.3	80	76	209	AXB014SPA
		1 ea.	AES027ELA, AES014ELA			41.7	50.2	91.5	100	88	220	AXB016SPA
		1 ea.	AES033ELA, AES016ELA			50.0	60.1	88.8	100	99	230	AXB016SPA

NOTE: See legend and notes for accessories.

ACCESSORY STATIC PRESSURE (in. wg)

Component	CFM									
	2250	2500	3000	3500	4000	4500	5000	5500	6000	6250
1 Heater Module	0.02	0.03	0.05	0.07	0.08	0.10	0.12	0.14	0.16	0.17
2 Heater Modules	0.03	0.05	0.07	0.09	0.12	0.14	0.16	0.19	0.21	0.20

The static pressure must be added to external static pressure. The sum and the evaporator entering-air cfm should then be used in conjunction with the Fan Performance tables to determine blower rpm and watts.

MULTIPLICATION FACTORS

Heater Rating Voltage	ACTUAL HEATER VOLTAGE									
	208	230	240	380	440	460	480	550	575	600
240 Volt	0.751	0.918	1.000							
480 Volt				0.626	0.840	0.918	1.000			
600 Volt								0.840	0.918	1.000

NOTE: The following equation converts kW of heat energy to Btuh: kW x 3.412 = Btuh.

LEGEND

FLA - Full Load Amps

MCA - Minimum Circuit Amps

MOCP - Maximum Overcurrent Protection

LRA - Locked Rotor Amps

NEC - National Electrical Code

* Heater capacity (kW) is based on heater voltage of 208 v, 240 v, 480 v, and 600 v. Heaters are rated at 240 v, 480 v, or 600 v. If power distribution voltage to unit varies from rated heater voltage, heater kW will vary accordingly. To determine heater

** Used to determine minimum disconnect size per NEC.

*** Fuse or HACR circuit breaker.

Fusing in the single point kit provides the required branch circuit protection.

NOTES

1. In compliance with NEC requirements for multimotor and combination load equipment (refer to NEC Articles 430 and 440), the overcurrent protective device for the unit shall be fuse or HACR breaker. Canadian units may be fuse or circuit breaker.

2. Unbalanced 3-Phase Supply Voltage - Never operate a motor where a phase imbalance in supply voltage is greater than 2%. Use the following formula to determine the percent of voltage imbalance.

EXAMPLE: Supply voltage is 460-3-60.

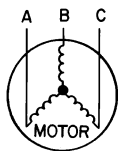

AB = 452 v
BC = 464 v
AC = 455 v

$$\begin{aligned} \text{Average Voltage} &= \frac{452 + 464 + 455}{3} \\ &= \frac{1371}{3} = 457 \end{aligned}$$

Determine maximum deviation from average voltage.

$$(AB) 457 - 452 = 5 \text{ V}$$

$$(BC) 464 - 457 = 7 \text{ V}$$

$$(AB) 457 - 455 = 2 \text{ V}$$

Maximum deviation is 7 v.

Determine percent voltage imbalance.

$$\begin{aligned} \% \text{ Voltage Imbalance} &= 100 \times \frac{7}{457} \\ &= 1.53\% \end{aligned}$$

This amount of phase imbalance is satisfactory as it is below the maximum allowable 2%.

IMPORTANT: If the supply voltage phase imbalance is more than 2 %, contact your local electric company immediately.



CONTROLS

OPERATING SEQUENCE

Cooling, Units Without Economizer — When thermostat calls for cooling, terminals G and Y1 are energized. The indoor fan contactor (IFC), reversing valve solenoid (RVS1) and compressor contactor no. 1 (C1) are energized and indoor-fan motor, compressor no. 1, and outdoor fans start. The out door-fan motor(s) run continuously while unit is cooling. On 090, 102-120 units, if the thermostat calls for a second stage of cooling by energizing Y2, compressor contactor no. 2 (C2) and reversing valve solenoid (RVS2) are energized and compressor no. 2 starts.

Heating, Units Without Economizer — Upon a request for heating from the space thermostat, terminal W1 will be energized with 24 v. The IFC, OFC, C1, and C2 will be energized. The reversing valves switch position and the indoor fan, outdoor fan, compressor no. 1, and compressor no. 2 are energized.

If the space temperature continues to fall while W1 is energized, W2 will be energized with 24 v, and the heater contactor(s) (HC) will be energized, which will energize the electric heater(s).

When the space thermostat is satisfied, W2 will be deenergized first, and the electric heater(s) will be deenergized. Upon a further rise in space temperature, W1 will be deenergized, and the reversing valve solenoids (RVS1 and RVS2) will be energized.

Defrost — When the temperature of the out-door coil drops below 28 F as sensed by the defrost thermostat (DFT2) and the defrost timer is at the end of a timed period (adjustable at 30, 50, or 90 minutes), reversing valve solenoids (RVS1 and RVS2) are energized and the OFC is deenergized. This switches the position of the reversing valves and shuts off the outdoor fan. The electric heaters (if installed) will be energized.

The unit continues to defrost until the coil temperature as measured by DFT2 reaches 65 F, or the duration of defrost cycle completes a 10-minute period.

During the Defrost mode, if circuit 1 defrosts first, RVS1 will oscillate between Heating and Cooling modes until the Defrost mode is complete.

At the end of the defrost cycle, the electric heaters (if installed) will be deenergized; the reversing valves switch and the out-door-fan motor will be energized. The unit will now operate in the Heating mode.

If the space thermostat is satisfied during a defrost cycle, the unit will continue in the Defrost mode until the time or temperature constraints are satisfied.

APPLICATION DATA

1. **OUTDOOR INSTALLATION** — Units approved for outdoor installation only.
2. **DUCTWORK** — Secure vertical discharge ductwork to roof curb. For horizontal discharge applications, either attach ductwork to unit, or use field-supplied flanges attached to the horizontal discharge openings and attach all ductwork to flanges.
3. **THERMOSTAT** — Use of 2-stage heating and cooling thermostat is recommended for all units.
4. **HEATING-TO-COOLING CHANGEOVER** — All units are automatic changeover from heating to cooling when automatic changeover thermostat and subbase are used.
5. **AIRFLOW** — Units are draw-thru on cooling and blow-thru on heating.
6. **MAXIMUM AIRFLOW** — To minimize the possibility of condensate blow-off from indoor coil, airflow through units should not exceed 500 cfm/ton on size 090, 102-120 units.

7. **MINIMUM AIRFLOW** — For cooling, minimum airflow is 300 cfm/ton.

8. **MINIMUM AMBIENT COOLING OPERATING TEMPERATURE** — The minimum temperature for standard units is 25 F.

9. **MAXIMUM OPERATING OUTDOOR-AIR TEMPERATURE** — The maximum temperature for standard units is 115 F.

10. **INTERNAL UNIT DESIGN** — Due to PHE's internal unit design (draw-thru over the motor), air path, and specially designed motors, the full horsepower (maximum continuous bhp) listed in the Physical Data table and the notes following each Fan Performance table can be utilized with confidence. Using PHE motors with the values listed in the Physical and Fan Performance Data tables *will not* result in nuisance tripping or premature motor failure. The unit warranty will not be affected.

GUIDE SPECIFICATIONS: PHE072-120

CABINET:

The cabinet shall be made of sturdy baked enamel coated galvanized steel. Base rails shall be 16 gauge steel and have fork lift slots and holes provided for lifting shackles. Unit shall be designed with convertible airflow and shipped ready for downflow applications with conversion to horizontal air flow accomplished by relocating two panels.

Return air compartments shall be insulated with not less than 1/2" of water resistant coated glass fiber and not less than 1/2" of aluminum foil faced glass fiber in the furnace/supply compartments.

COOLING SECTION:

Units shall be factory charged and operationally ready. Each refrigeration circuit shall have a compressor, with internal overload protection, high and low pressure switches, filter drier and copper tube/aluminum fin evaporator and condenser coils.

Units shall be capable of cooling operation down to 25°F as shipped from the factory.

COILS:

The evaporator and condenser coils shall be fabricated with aluminum fins mechanically bonded to copper tubing. Both coils shall be pressure tested prior to assembly into the unit and electronically leak tested after assembly onto the unit. The evaporator coil shall be protected from dust and debris on the return air side by factory installed 2" air filters.

CONDENSER FAN:

The unit shall have a single direct drive propeller fan/motor assembly mounted directly to a vertical-discharge grille panel that is easily removable. Motors shall have permanently lubricated sleeve bearings and inherent overload protection.

EVAPORATOR BLOWER:

The units shall have a single belt driven evaporator blower. The motor shall have permanently lubricated ball bearings and internal overload protection. An adjustable motor drive sheave for matching air flow requirements shall be standard.