



9.2 – 9.5 EER PACKAGE AIR CONDITIONER, 6.9 to 14.4 kw, 2 – 4 TONS 3-Phase, 400-3-50

REFRIGERATION CIRCUIT

- Environmentally sound R-410A refrigerant
- Scroll compressors standard on all models
- Copper tube/aluminum fin condenser and evaporator coils

EASY TO INSTALL AND SERVICE

- Installs easily on a rooftop or at ground level
- Easy three-panel accessibility for maintenance and installation
- Easily converts to down discharge applications

BUILT TO LAST

- Wire grille
- Pre-painted steel cabinet
- PSC indoor blower motor on all models
- Vertical condenser fan discharge
- Full perimeter steel base rails
- High and Low pressure switches factory installed



UNIT PERFORMANCE DATA							
Model Number	Volt-Ph-Hz				Sound Ratings (dBA)	Unit Dimensions H x W x D Inches (mm)	Operating Weight lbs / kg
		Nominal Capacity kw / BTU/h	Standard CFM / Ls	EER			
PA4E24000Z000A	400-3-50	6.9 / 23,400	800 / 378	9.5	75	40 x 48 ³ / ₁₆ x 32 ⁵ / ₈ (1016 x 1224 x 829)	280 / 127
PA4E30000Z000A	400-3-50	8.6 / 29,200	1000 / 472	9.5	75	42 x 48 ³ / ₁₆ x 32 ⁵ / ₈ (1067 x 1224 x 829)	312 / 142
PA4E36000Z000A	400-3-50	10.7 / 36,700	1200 / 567	9.5	75	38 x 48 ³ / ₁₆ x 32 ⁵ / ₈ (965 x 1224 x 829)	318 / 144
PA4E48000Z000A	400-3-50	14.4 / 49,300	1600 / 756	9.2	78	42 x 48 ³ / ₁₆ x 44 ¹ / ₈ (1067 x 1226 x 1122)	368 / 167

TABLE OF CONTENTS

FEATURES	1
MODEL NUMBER NOMENCLATURE	2
ARI CAPACITIES	3
PHYSICAL DATA	3
ACCESSORIES	4
BASE UNIT DIMENSIONS	6
ACCESSORY ROOF CURB	8
SELECTION PROCEDURE	9
PERFORMANCE DATA	10
TYPICAL PIPING AND WIRING	16
APPLICATION DATA	17
ELECTRICAL DATA	17
TYPICAL WIRING SCHEMATICS	18
CONTROLS	19
GUIDE SPECIFICATIONS	19

MODEL NUMBER NOMENCLATURE

MODEL NOMENCLATURE										
MODEL SERIES	P	A	4	E	24	000	Z	000	A	1
P = Package										
A = Air Conditioner										
4 = R-410A										
E = Series										
24 = 24,000 BTUH = 2 Tons										
30 = 30,000 BTUH = 2.5 Tons										
36 = 36,000 BTUH = 3 Tons										
48 = 48,000 BTUH = 4 Tons										
						NOMINAL COOLING BTUH				
000 = N/A						NOMINAL HEATING BTUH				
Z = 400-3-50						VOLTAGE				
000 = N/A						FACTORY INSTALLED OPTIONS				
Sales Model Digit										
Engineering Digit										

Cooling Capacities and Efficiencies

PA4E	NET COOLING CAPACITIES (kW)	STANDARD CFM/L/s	NET COOLING CAPACITY (Btuh)	EER	kW
24	6.9	800/378	23400	9.5	6.9
30	8.6	1000/472	29200	9.5	8.6
36	10.7	1200/567	36700	9.5	10.7
48	14.4	1600/756	49300	9.2	14.4

LEGEND

dB—Sound Levels (decibels)

db—Dry Bulb

wb—Wet Bulb

† Tested in accordance with U.S. Government DOE Department of Energy) test procedures and/or ARI Standards 210/240—2008.

Notes:

1. Ratings are net values, reflecting the effects of circulating fan heat.

Ratings are based on:

Cooling Standard: 80°F (26.7°C) db, 67°Fwb (19.4°C) indoor entering—air temperature and 95°F db (35°C) outdoor entering—air temperature.

2. Before purchasing this appliance, read important energy cost and efficiency information available from your retailer.

A-WEIGHTED SOUND POWER LEVEL (dBA)

MODEL PA4E	STANDARD RATING	TYPICAL OCTAVE BAND SPECTRUM (dBA) (without tone adjustment)						
		125	250	500	1000	2000	4000	8000
24	75	60.4	58.3	64.8	66.9	64.3	59.8	51.8
30	75	58.2	59.2	65.8	67.7	64.8	61.8	53.6
36	75	60.4	61.6	66.9	67.8	64.6	60.7	52.8
48	78	65.2	69.7	72.7	72.9	69.8	65.8	57.9

NOTE: Tested in accordance with ARI Standard 270 (not listed in ARI).

PHYSICAL DATA

UNIT SIZE	24	30	36	48
NOMINAL CAPACITY (ton)	2	2-1/2	3	4
SHIPPING WEIGHT lb.	287	319	325	377
SHIPPING WEIGHT (kg)	130	145	147	171
40ft. HC CONTAINER LOAD (QTY)	44	44	44	36
COMPRESSORS	Scroll			
Quantity	1			
REFRIGERANT (R-410A)	Piston			
Quantity lb	6.0	5.6	9.5	9.4
Quantity (kg)	2.7	2.5	4.3	4.3
REFRIGERANT METERING DEVICE	Piston			
OUTDOOR COIL				
Rows...Fins/in.	1...17	1...17	2...17	2...17
Rows...Fins/cm	1...6.7	1...6.7	2...6.7	2...6.7
Face Area (sq ft)	10.9	12.7	9.1	12.3
Face Area (sq m)	1	1.18	0.85	1.14
OUTDOOR FAN				
Nominal Cfm	2350	2350	2350	3300
Nominal L/s	1109	1109	1109	1557
Diameter in.	22	22	22	22
Diameter (mm)	559	559	559	559
Motor Hp (Rpm)	1/4 (900)	1/4 (900)	1/4 (900)	1/3 (1340)
Motor Hp (kW)	186	373	373	248
INDOOR COIL				
Rows...Fins/in.	3...15	3...15	3...15	4...15
Rows...Fins/cm	3...5.9	3...5.9	3...5.9	4...5.9
Face Area (sq ft)	3.7	3.7	3.7	4.7
Face Area (sq m)	0.34	0.34	0.34	0.44
INDOOR BLOWER				
Nominal Cooling Airflow (Cfm)	800	1000	1200	1600
Nominal Cooling Airflow (L/s)	378	472	566	756
Wheel Size in.	10x10	10x10	10x10	11x10
Wheel Size (cm)	25.4x25.4	25.4x25.4	25.4x25.4	27.9x25.4
Motor HP	1/4	1/2	1/2	1
Motor (kW)	186	373	373	746
HIGH-PRESSURE SWITCH				
Cut-out psig	650			
Reset psig	420			
Cut-out kPa	4482			
Reset kPa	2896			
LOW-PRESSURE SWITCH				
Cut-out psig	20			
Reset psig	45			
Cut-out kPa	138			
Reset kPa	310			
RETURN-AIR FILTERS†‡				
Throwaway Size in.	20x20x1	20x24x1	24x30x1	24x36x1
Throwaway Size (mm)	508x508x25	508x610x25	610x762x25	610x914x25

† Required filter sizes shown are based on the larger of the ARI (Air Conditioning and Refrigeration Institute) rated cooling airflow or the heating airflow velocity of 300 ft/minute for throwaway type or 450 ft/minute for high-capacity type. Air filter pressure drop for non-standard filters must not exceed 0.08 IN. W.C.

‡ If using accessory filter rack refer to the filter rack installation instructions for correct filter sizes and quantity.

ACCESSORIES

ROOF CURBS		
Model Number	Description	Use With Model Size
CPRFCURB010A00	Roof Curb, 11" High	24 – 48
CPRFCURB011A00	Roof Curb, 14" High	24 – 48
CPRFCURB012A00	Roof Curb, 11" High	48
CPRFCURB013A00	Roof Curb, 14" High	48

Note: CPRFCURB010A00 AND CPRFCURB011A00 can be used with 42–60 size units with some overhang.

ADAPTER CURBS		
Model Number	Description	Use With Model Size
CPADCURB001A00	Adapter Curb for use with NPRFCURB006A00 & NPRFCURB007A00	30 – 36
CPADCURB002A00	Adapter Curb for use with NPRFCURB008A00 & NPRFCURB009A00	42 – 48

MANUAL FRESH AIR DAMPERS		
Model Number	Description	Use With Model Size
CPMANDPR007A00	Manual Outside Air Damper – External w/filter rack and 1" filter	24 – 36
CPMANDPR008A00		48

INTERNAL FILTER RACK and FILTER (shipped with 1" filters)		
Model Number	Description	Use With Model Size
CPFILTRK007A00	Internal Filter Rack	24 – 36
CPFILTRK008A00		48

DUCT TRANSITIONS		
Model Number	Description	Use With Model Size
NPDUCLG002A00	Square to Round (1 set of 2, use with horizontal duct flanges only)	24 – 48

LOW AMBIENT, ANTI-CYCLE TIMER		
Model Number	Description	Use With Model Size
AXB035LAA	Low ambient Control – enables cooling system to operate down to 0 Deg. F by cycling condenser fan on and off	ALL
NRTIMEGD001A00	5 minute anti-cycle timer (Note: many thermostats have inherent anti-cycle timer logic)	ALL

CRANKCASE HEATER – BELLY BAND TYPE		
Model Number	Description	Use With Model Size
NCPCRKHTR003A00	Crankcase Heater	ALL

ELECTRIC HEATERS

CATALOG ORDERING NO.	NOMINAL CAPACITY (kW)	FUSED (Yes/No)	STAGES	USED WITH SIZES			
				24	30	36	48
CPHEATER076A00	6.5	No	1	X	X	X	X
CPHEATER077A00	8.7	No	1	X	X	X	X
CPHEATER078A00	13.0	No	1		X	X	X
CPHEATER079A00	17.4	No	1				X

NOTE: Electric heaters are rated at 400v. Refer to Multiplication Factors table for other voltages.

X = Approved combinations.

Minimum Airflow for Safe Electric Heater Operation (CFM)

SIZE	24	30	36	48
Cfm	800	1000	1200	1600
L/s	378	472	567	756

Accessory Electric Heat Pressure Drop: Inches Water Column (CFM), Pa (L/s)

HEATER kW	CFM								
	600	800	1000	1200	1400	1600	1800	2000	2200
6.5–17.4	0.030	0.033	0.037	0.042	0.047	0.052	0.060	0.067	0.075
	L/s								
	283	378	472	569	661	755	850	944	1038
	7.5	8.2	9.2	10.4	11.7	12.9	14.9	16.7	18.7

ECONOMIZER

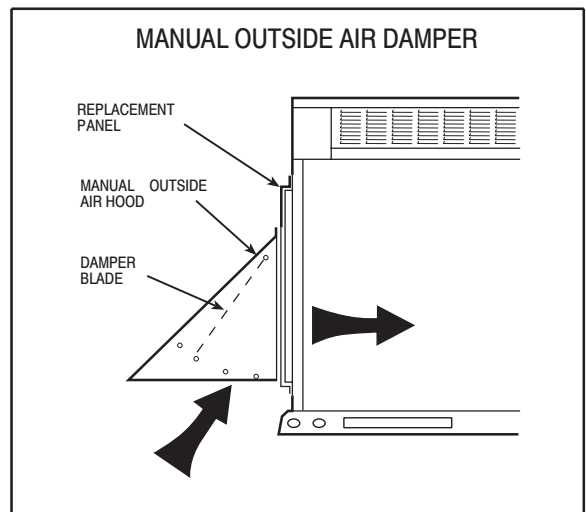
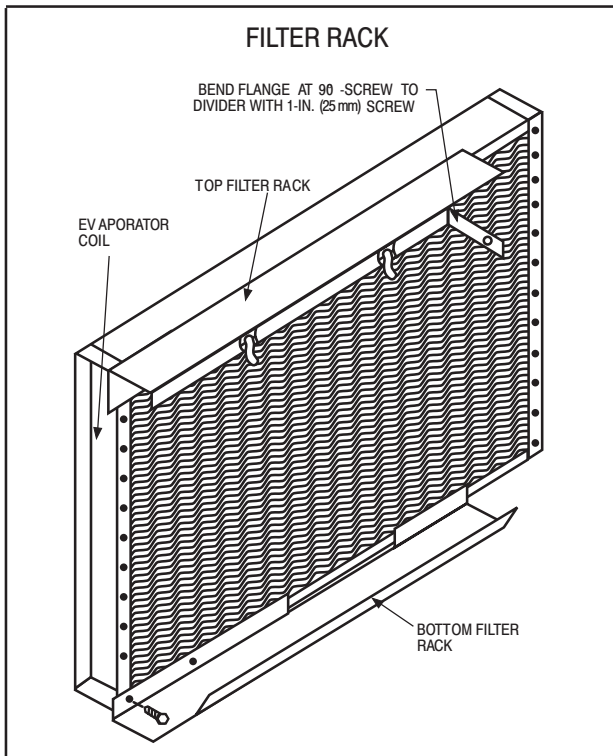
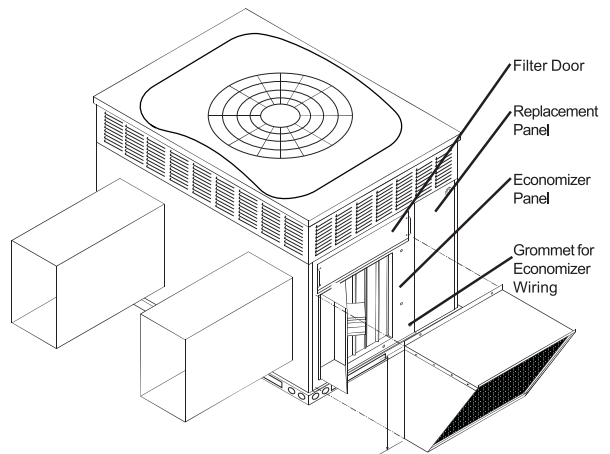
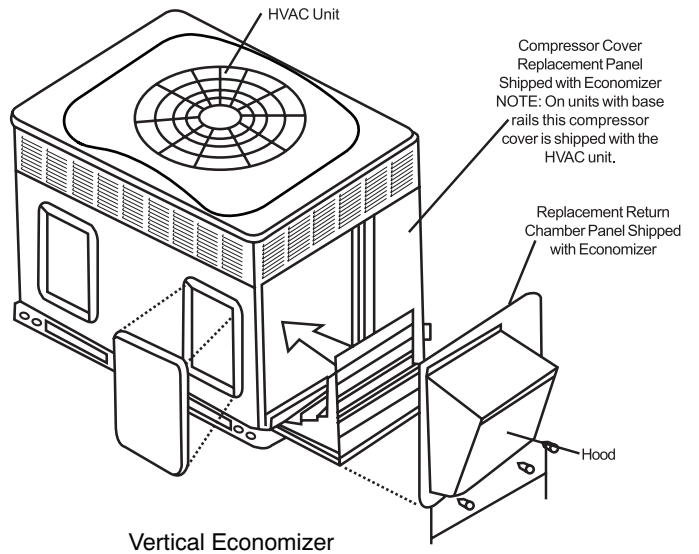
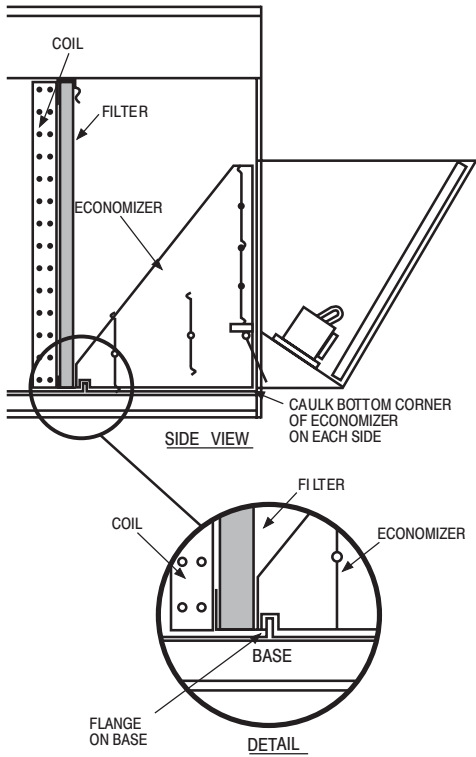

A09376

UNIT DIMENSIONS – PA4E24–36

UNIT	ELECTRICAL CHARACTERISTICS	UNIT WT.		UNIT HEIGHT	CENTER OF GRAVITY IN/MM				
		LB.	KG.		X	Y	Z		
PA4E24	400-3-50	280	127.0	40	1016	18-1/2 [470]	14-1/2 [368]	16	406
PA4E30	400-3-50	312	141.5	42	1067	19-1/2 [495]	15-1/2 [394]	17-5/8 [447]	
PA4E36	400-3-50	318	144.2	38	965	19-1/2 [495]	15-3/8 [387]	16-1/2 [419]	

REQUIRED CLEARANCES TO COMBUSTIBLE MATL.

CORNER WEIGHT LB/KG		INCHES (MM)	
"1"	"2"	"3"	"4"
80	53	24	61
28	86	39	99
88	64	29	95
43	31	97	44

CORNER WEIGHT LB/KG		INCHES (MM)	
"1"	"2"	"3"	"4"
80	53	24	61
28	86	39	99
88	64	29	95
43	31	97	44

CORNER WEIGHT LB/KG		INCHES (MM)	
"1"	"2"	"3"	"4"
80	53	24	61
28	86	39	99
88	64	29	95
43	31	97	44

CORNER WEIGHT LB/KG		INCHES (MM)	
"1"	"2"	"3"	"4"
80	53	24	61
28	86	39	99
88	64	29	95
43	31	97	44

CORNER WEIGHT LB/KG		INCHES (MM)	
"1"	"2"	"3"	"4"
80	53	24	61
28	86	39	99
88	64	29	95
43	31	97	44

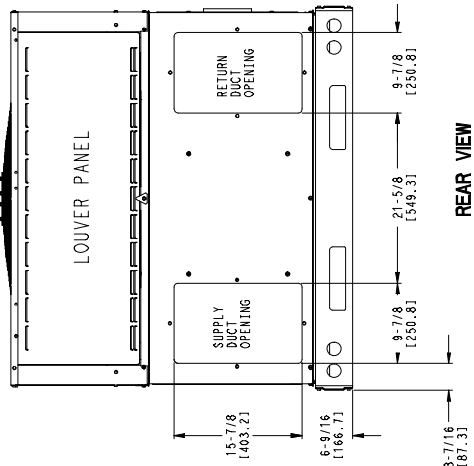
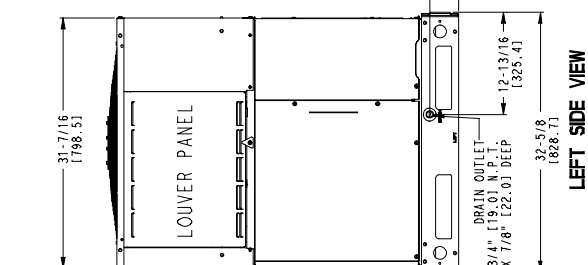
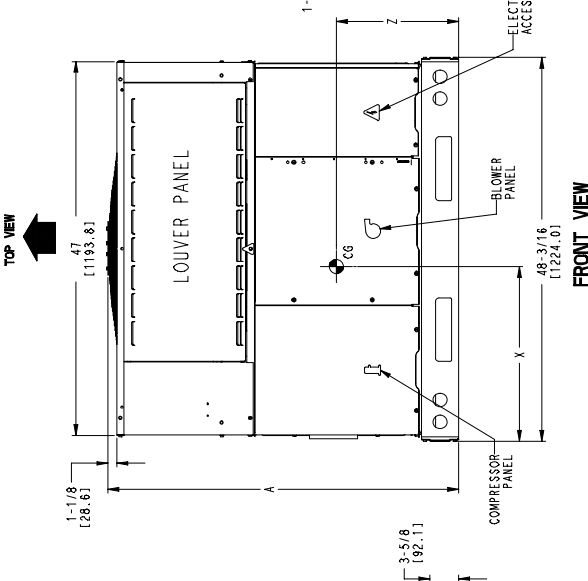
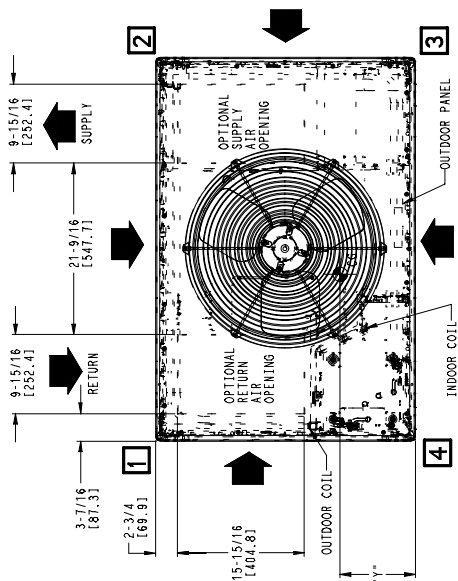

50ES500441
REV 3.0

UNIT DIMENSIONS – PA4E48

UNIT	ELECTRICAL CHARACTERISTICS	UNIT WT.		UNIT HEIGHT		CENTER OF GRAVITY IN/MM					
		LB	KG	"-0"	"-0"	X	Y	Z			
PA4E48	400-3-50	388	166.9	42	1067	19-1/2	495	17-5/8	448	18	457

REQUIRED CLEARANCES TO COMBUSTIBLE MATL.

UNITS	CORNER WEIGHT LB/KG		INCHES (MM)					
	"-1"	"-2"	"-1"	"-2"				
PA4E48	83	38	61	28	84	38	140	64

INCHES (MM)	
TOP OF UNIT	14 (355.6)
DUCT SIDE OF UNIT	2 (50.8)
SIDE OPPOSITE DUCTS	14 (355.6)
BOTTOM OF UNIT	0 (0.0)
ELECTRICAL PANEL	36 (914.4)

INCHES (MM)	
BETWEEN UNITS, POWER ENTRY SIDE	42 (1066.8)
UNIT AND BLOWER ACCESS PANELS, POWER ENTRY SIDE	36 (914.4)
UNIT AND BLOWER ACCESS PANELS, OTHER	36 (914.4)
GROUND SURFACES, POWER ENTRY SIDE	42 (1066.8)

INCHES (MM)	
EVAP. COIL ACCESS SIDE	42 (1066.8)
POWER ENTRY SIDE (EXCEPT FOR NEC REQUIREMENTS)	42 (1066.8)
UNIT TOP	48 (1219.2)
SIDE OPPOSITE DUCTS	36 (914.4)
DUCT PANEL	12 (304.8)

*MINIMUM DISTANCES: IF UNIT IS PLACED LESS THAN 12 (304.8) FROM WALL SYSTEM, THEN SYSTEM PERFORMANCE MAYBE COMPROMISED.

DIMENSIONS IN [] ARE IN MILLIMETERS

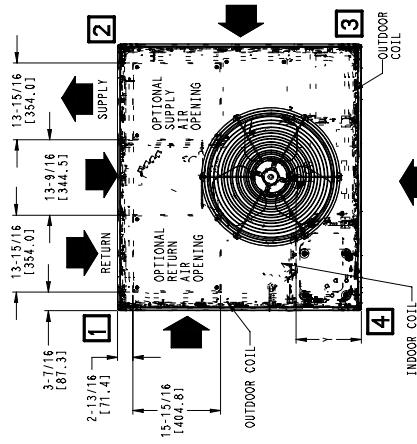

TOP VIEW

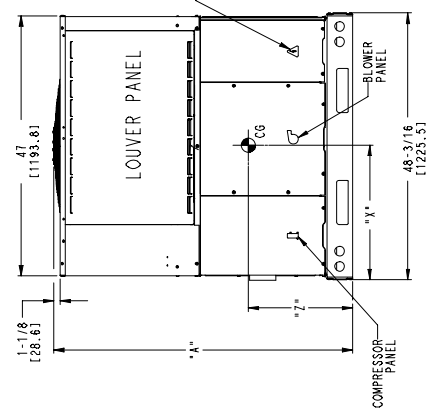

FRONT VIEW

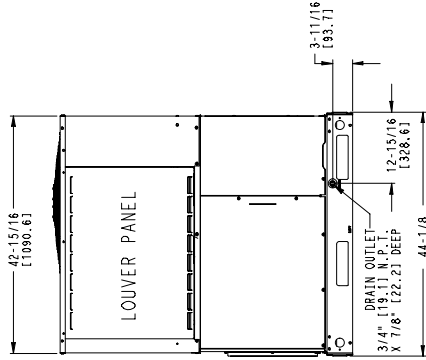

LEFT SIDE VIEW

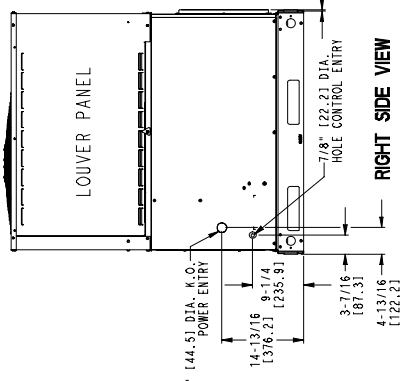

RIGHT SIDE VIEW

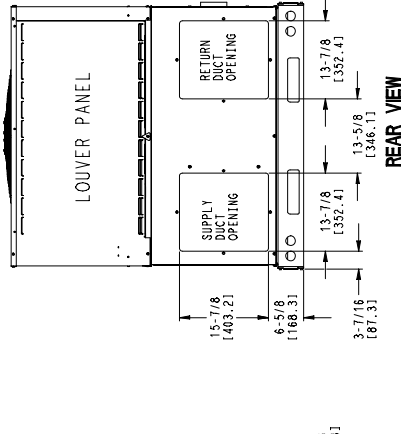

REAR VIEW

50ESS00442	REV 3.0
------------	---------

ACCESSORY ROOF CURB – PA4E24–48

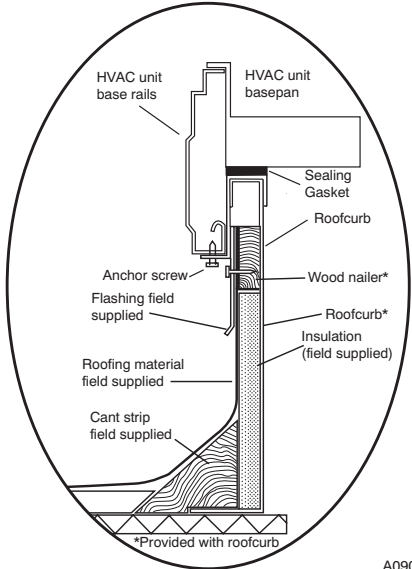

A09090

ROOF CURB DETAIL

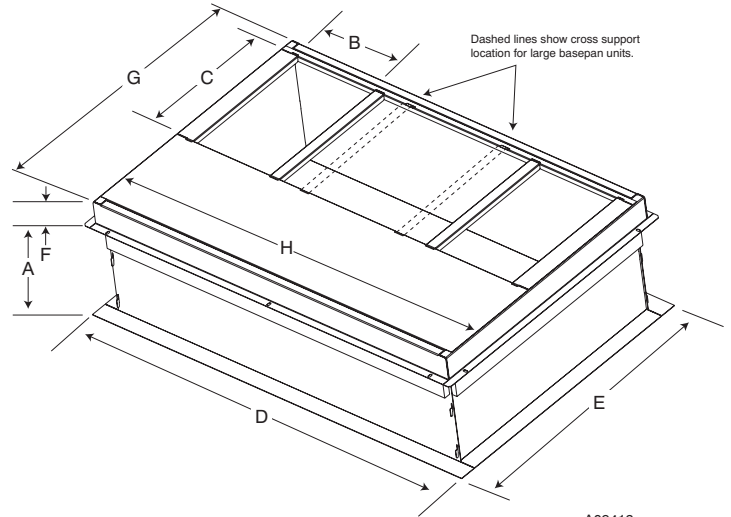

SMALL/COMMON CURB

A09413

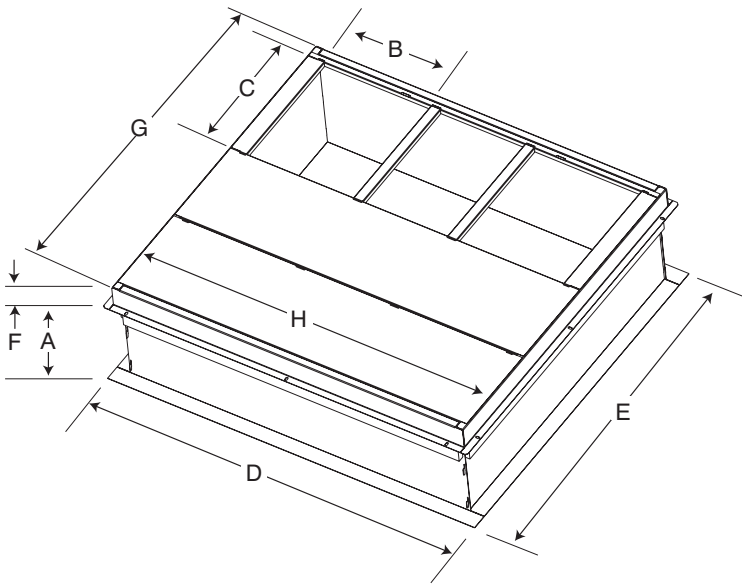

LARGE CURB

A09415

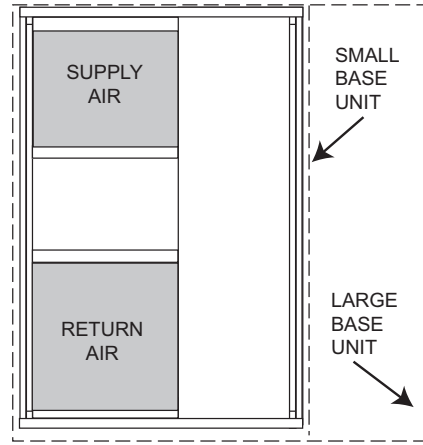

UNIT PLACEMENT ON COMMON CURB

A09094

SMALL OR LARGE BASE UNIT

A09414

UNIT SIZE	CATALOG NUMBER	A IN. (mm)	B (small/common curb) IN. (mm)*	B (large curb) IN. (mm)*	C IN. (mm)	D IN. (mm)	E IN. (mm)	F IN. (mm)	G IN. (mm)	H IN. (mm)
Small or Large	CPRFCURB010A00	11 (279)	10 (254)	14 (356)	16 (406)	47.8 (1214)	32.4 (822)	2.7 (69)	30.6 (778)	46.1 (1170)
	CPRFCURB011A00	14 (356)					43.9 (1116)			
Large	CPRFCURB012A00	11 (279)	14 (356)	14 (356)	16 (406)	47.8 (1214)	32.4 (822)	2.7 (69)	42.2 (1072)	46.1 (1170)
	CPRFCURB013A00	14 (356)					43.9 (1116)			

* Part Numbers CPRFCURB010A00 and CPRFCURB011A00 can be used on both small and large basepan units. The cross supports must be located based on whether the unit is a small basepan or a large basepan.

NOTES:

1. Roof curb must be set up for unit being installed.
2. Seal strip must be applied, as required, to unit being installed.
3. Roof curb is made of 16-gauge steel.
4. Attach ductwork to curb (flanges of duct rest on curb).
5. Insulated panels: 1-in. (25.4 mm) thick fiberglass 1 lb. density.

SELECTION PROCEDURE (WITH EXAMPLE)

1. Determine cooling and heating requirements at design conditions:

Given:

Required Cooling Capacity (TC) . . . 10.4kW (35,000 Btuh)
Sensible Heat Capacity (SHC) 7.3 kW (25,000 Btuh)
Required Heating Capacity 6.4 kW (22,000 Btuh)
Condenser Entering Air Temperature 35°C (95°F)
Indoor–Air Temperature 26.7°C (80°F) edb
. 19°C (67°F) ewb
Evaporator Air Quantity 543 L/s (1150 CFM)
External Static Pressure 24.9 Pa (0.1 IN. W.C.)
Electrical Characteristics 400–3–50

2. Select unit based on required cooling capacity.

A. SI

Enter Net Cooling Capacities SI table at condenser entering temperature of 35°C, which matches design Condenser Entering Air Temperature. At 566 L/s and 19°C ewb (entering wet bulb) will provide a total capacity of 12.5 kW and a SHC of 9.1 kW. Calculate SHC correction, if required using Note 3 of Net Cooling Capacities Table.

3. Select electric heat.

The required heating capacity is 6.4 kW (22,000 Btuh)–(given).

Determine additional electric heat capacity in kW.

$$\frac{22,000 \text{ Btuh}}{3,414 \text{ Btuh/kW}} = 6.44 \text{ kW of heat required}$$

Enter the Electric Heater table for the unit. The 6.5 kW heater at 400v most closely satisfies the heating required.

4. Determine fan speed and power requirements at design conditions.

Before entering the air delivery tables, calculate the total static pressure required. From the given Filter Pressure Drop Table find:

External Static Pressure	12.5 Pa (0.05 IN. W.C.)
Filter	<u>+20/0 Pa (0.12 IN. W.C.)</u>
Total Static Pressure	42.4 Pa (0.17 IN. W.C.)

Enter the table for Wet Coil Air Delivery—Horizontal Discharge, 400 V. At 0.424 Pa (0.17 IN. W.C.) external static pressure and low speed, the fan will deliver 561 L/s (1188 CFM).

PERFORMANCE DATA

PA4E24

PA4E24 COOLING PERFORMANCE TABLE - English										
Temp (°F) Outdoor Air Entering Condenser		Evaporator Air—Cfm—BF								
		700/0.034			800/0.043			900/0.051		
		Evaporator Air—Ewb (F)								
		62	67	72	62	67	72	62	67	72
75	TC	23.2	25.9	27.9	23.7	26.3	28.1	24.1	26.4	28.0
	SHC	20.4	17.1	13.6	21.8	17.9	13.8	23.1	18.6	14.0
	kW	1.9	1.9	1.9	1.9	2.0	2.0	2.0	2.1	2.1
85	TC	21.9	24.6	27.0	22.4	24.9	27.1	23.0	25.1	27.0
	SHC	19.8	16.6	13.2	21.1	17.5	13.5	22.0	18.3	13.7
	kW	2.0	2.1	2.1	2.1	2.2	2.2	2.2	2.3	2.3
95	TC	20.5	23.1	25.7	21.2	23.4	25.9	21.9	23.6	25.9
	SHC	19.1	16.0	12.8	20.3	17.0	13.2	20.9	17.8	13.5
	kW	2.2	2.3	2.3	2.3	2.4	2.4	2.4	2.5	2.5
105	TC	19.3	21.5	24.2	20.1	21.9	24.4	20.7	22.1	24.4
	SHC	18.4	15.4	12.3	19.2	16.4	12.7	19.8	17.3	13.0
	kW	2.4	2.6	2.6	2.5	2.7	2.7	2.6	2.7	2.8
115	TC	18.1	20.0	22.6	18.8	20.3	22.8	19.4	20.4	22.7
	SHC	17.3	14.8	11.7	18.0	15.8	12.1	18.6	16.6	12.4
	kW	2.7	2.8	2.8	2.8	2.9	2.9	2.9	3.0	3.0
125	TC	16.8	18.3	20.8	17.5	18.6	20.9	18.1	18.7	20.8
	SHC	16.1	14.2	11.1	16.8	15.2	11.5	17.3	16.0	11.8
	kW	2.9	3.0	3.1	3.0	3.2	3.2	3.2	3.3	3.3

PA4E24 COOLING PERFORMANCE TABLE - SI										
Temp (°C) Outdoor Air Entering Condenser		Evaporator Air—L/s—BF								
		330/0.034			377/0.043			425/0.51		
		Evaporator Air—Ewb (°C)								
		17	19	22	17	19	22	17	19	22
24	TC	6.8	7.6	8.2	6.9	7.7	8.2	7.1	7.7	8.2
	SHC	6.0	5.0	4.0	6.4	5.3	4.0	6.8	5.4	4.1
	kW	1.9	1.9	1.9	1.9	2.0	2.0	2.0	2.1	2.1
29	TC	6.4	7.2	7.9	6.5	7.3	7.9	6.8	7.4	7.9
	SHC	5.8	4.9	3.9	6.2	5.1	4.0	6.5	5.4	4.0
	kW	2.0	2.1	2.1	2.1	2.2	2.2	2.2	2.3	2.3
35	TC	6.0	6.8	7.5	6.2	6.9	7.6	6.4	6.9	7.6
	SHC	5.6	4.7	3.8	5.9	5.0	3.9	6.1	5.2	3.9
	kW	2.2	2.3	2.3	2.3	2.4	2.4	2.4	2.5	2.5
41	TC	5.6	6.3	7.1	5.9	6.4	7.2	6.1	6.5	7.2
	SHC	5.4	4.5	3.6	5.6	4.8	3.7	5.8	5.1	3.8
	kW	2.4	2.6	2.6	2.5	2.7	2.7	2.6	2.7	2.8
46	TC	5.3	5.8	6.6	5.5	5.9	6.7	5.7	6.0	6.7
	SHC	5.1	4.3	3.4	5.3	4.6	3.6	5.4	4.9	3.6
	kW	2.7	2.8	2.8	2.8	2.9	2.9	2.9	3.0	3.0
52	TC	4.9	5.4	6.1	5.1	5.4	6.1	5.3	5.5	6.1
	SHC	4.7	4.1	3.2	4.9	4.4	3.4	5.1	4.7	3.5
	kW	2.9	3.0	3.1	3.0	3.2	3.2	3.2	3.3	3.3

See Legend and Notes following.

PERFORMANCE DATA (CONT)

PA4E30

PA4E30 COOLING PERFORMANCE TABLE - English										
Temp (F) Outdoor Air Entering Condenser		Evaporator Air—Cfm—BF								
		875/0.047			1000/0.061			1125/0.074		
		Evaporator Air—Ewb (F)								
		62	67	72	62	67	72	62	67	72
75	TC	28.9	31.7	34.8	29.4	32.1	35.3	29.9	32.2	35.5
	SHC	25.6	21.3	17.1	27.2	22.5	17.7	28.6	23.5	18.2
	kW	2.4	2.5	2.5	2.5	2.6	2.6	2.6	2.7	2.8
85	TC	27.7	30.3	33.4	28.1	30.7	33.7	28.8	30.8	33.9
	SHC	25.0	20.7	16.5	26.7	21.9	17.1	27.6	22.9	17.6
	kW	2.7	2.7	2.8	2.8	2.8	2.9	2.8	3.0	3.0
95	TC	26.4	28.9	31.8	27.0	29.2	32.1	27.7	29.3	32.2
	SHC	24.3	20.2	16.0	25.8	21.3	16.6	26.5	22.4	17.0
	kW	3.0	3.0	3.0	3.0	3.1	3.2	3.1	3.2	3.3
105	TC	25.1	27.4	30.2	25.9	27.7	30.5	26.5	27.7	30.5
	SHC	23.7	19.6	15.4	24.7	20.8	16.0	25.3	21.8	16.5
	kW	3.3	3.3	3.4	3.3	3.4	3.5	3.4	3.6	3.6
115	TC	23.9	25.9	28.6	24.7	26.1	28.8	25.2	26.2	28.8
	SHC	22.9	19.0	14.8	23.6	20.2	15.4	24.1	21.2	15.9
	kW	3.6	3.7	3.7	3.7	3.8	3.8	3.8	3.9	4.0
125	TC	22.8	24.5	27.2	23.5	24.7	27.4	24.0	24.7	27.3
	SHC	21.8	18.5	14.3	22.5	19.6	14.9	23.0	20.6	15.4
	kW	4.0	4.1	4.1	4.1	4.2	4.2	4.2	4.3	4.4

PA4E30 COOLING PERFORMANCE TABLE - SI										
Temp (°C) Out- door Air Entering Condenser		Evaporator Air—L/s—BF								
		413/0.047			472/0.061			531/0.074		
		Evaporator Air—Ewb (°C)								
		17	19	22	17	19	22	17	19	22
24	TC	8.5	9.3	10.2	8.6	9.4	10.3	8.8	9.4	10.4
	SHC	7.5	6.2	5.0	8.0	6.6	5.2	8.4	6.9	5.3
	kW	2.4	2.5	2.5	2.5	2.6	2.6	2.6	2.7	2.8
29	TC	8.1	8.9	9.8	8.2	9.0	9.9	8.5	9.0	9.9
	SHC	7.3	6.1	4.8	7.8	6.4	5.0	8.1	6.7	5.2
	kW	2.7	2.7	2.8	2.8	2.8	2.9	2.8	3.0	3.0
35	TC	7.7	8.5	9.3	7.9	8.5	9.4	8.1	8.6	9.4
	SHC	7.1	5.9	4.7	7.6	6.2	4.9	7.8	6.6	5.0
	kW	3.0	3.0	3.0	3.0	3.1	3.2	3.1	3.2	3.3
41	TC	7.4	8.0	8.9	7.6	8.1	8.9	7.8	8.1	8.9
	SHC	6.9	5.7	4.5	7.2	6.1	4.7	7.4	6.4	4.8
	kW	3.3	3.3	3.4	3.3	3.4	3.5	3.4	3.6	3.6
46	TC	7.0	7.6	8.4	7.2	7.7	8.4	7.4	7.7	8.4
	SHC	6.7	5.6	4.3	6.9	5.9	4.5	7.1	6.2	4.7
	kW	3.6	3.7	3.7	3.7	3.8	3.8	3.8	3.9	4.0
52	TC	6.7	7.2	8.0	6.9	7.2	8.0	7.0	7.3	8.0
	SHC	6.4	5.4	4.2	6.6	5.8	4.4	6.7	6.1	4.5
	kW	4.0	4.1	4.1	4.1	4.2	4.2	4.2	4.3	4.4

See Legend and Notes following.

PERFORMANCE DATA (CONT)

PA4E36

PA4E36 COOLING PERFORMANCE TABLE - English										
Temp (F) Outdoor Air Entering Condenser		Evaporator Air—Cfm—BF								
		1050/0.073			1200/0.091			1350/0.11		
		Evaporator Air—Ewb (F)								
		62	67	72	62	67	72	62	67	72
75	TC	36.0	39.5	42.1	36.7	40.0	42.1	37.2	40.2	42.0
	SHC	31.6	26.6	21.2	33.6	27.8	21.5	35.1	28.6	21.7
	kW	3.0	3.0	3.0	3.1	3.1	3.2	3.3	3.3	3.3
85	TC	34.4	38.0	41.1	35.2	38.5	41.3	35.7	38.7	41.1
	SHC	30.9	26.0	20.8	32.7	27.2	21.3	34.6	28.3	21.5
	kW	3.3	3.4	3.4	3.4	3.5	3.5	3.6	3.7	3.7
95	TC	32.8	36.2	39.5	33.4	36.7	39.8	33.9	37.0	39.7
	SHC	30.3	25.3	20.2	32.0	26.6	20.7	33.7	27.7	21.0
	kW	3.6	3.7	3.7	3.8	3.9	3.9	3.9	4.0	4.0
105	TC	31.1	34.4	37.6	31.6	34.8	37.8	32.6	34.9	37.8
	SHC	29.5	24.6	19.5	31.2	25.8	20.0	32.5	26.9	20.3
	kW	4.0	4.1	4.1	4.1	4.3	4.3	4.2	4.4	4.4
115	TC	29.2	32.4	35.3	30.2	32.6	35.5	31.0	32.7	35.2
	SHC	28.5	23.7	18.6	30.1	25.0	19.1	31.0	26.1	19.4
	kW	4.4	4.5	4.5	4.5	4.7	4.7	4.7	4.8	4.8
125	TC	27.5	30.1	32.7	32.4	30.3	32.6	29.1	30.4	32.4
	SHC	27.4	22.8	17.6	18.2	24.0	18.0	29.1	25.1	18.2
	kW	4.9	5.0	5.0	5.3	5.1	5.1	5.1	5.2	5.3

PA4E36 COOLING PERFORMANCE TABLE - SI										
Temp (°C) Outdoor Air Entering Condenser		Evaporator Air—L/s—BF								
		496/0.073			566/0.091			637/0.11		
		Evaporator Air—Ewb (°C)								
		17	19	22	17	19	22	17	19	22
24	TC	10.5	11.6	12.3	10.8	11.7	12.3	10.9	11.8	12.3
	SHC	9.3	7.8	6.2	9.8	8.1	6.3	10.3	8.4	6.4
	kW	3.0	3.0	3.0	3.1	3.1	3.2	3.3	3.3	3.3
29	TC	10.1	11.1	12.0	10.3	11.3	12.1	10.5	11.3	12.1
	SHC	9.1	7.6	6.1	9.6	8.0	6.2	10.1	8.3	6.3
	kW	3.3	3.4	3.4	3.4	3.5	3.5	3.6	3.7	3.7
35	TC	9.6	10.6	11.6	9.8	10.7	11.6	9.9	10.8	11.6
	SHC	8.9	7.4	5.9	9.4	7.8	6.1	9.9	8.1	6.1
	kW	3.6	3.7	3.7	3.8	3.9	3.9	3.9	4.0	4.0
41	TC	9.1	10.1	11.0	9.3	10.2	11.1	9.6	10.2	11.1
	SHC	8.7	7.2	5.7	9.1	7.6	5.9	9.5	7.9	6.0
	kW	4.0	4.1	4.1	4.1	4.3	4.3	4.2	4.4	4.4
46	TC	8.6	9.5	10.4	8.8	9.6	10.4	9.1	9.6	10.3
	SHC	8.3	6.9	5.5	8.8	7.3	5.6	9.1	7.6	5.7
	kW	4.4	4.5	4.5	4.5	4.7	4.7	4.7	4.8	4.8
52	TC	8.1	8.8	9.6	9.5	8.9	9.6	8.5	8.9	9.5
	SHC	8.0	6.7	5.2	5.3	7.0	5.3	8.5	7.4	5.3
	kW	4.9	5.0	5.0	5.3	5.1	5.1	5.1	5.2	5.3

See Legend and Notes following.

PERFORMANCE DATA (CONT)

PA4E48

PA4E48 COOLING PERFORMANCE TABLE - English										
Temp (°F) Outdoor Air Entering Condenser		Evaporator Air—Cfm—BF								
		1400/0.024			1600/0.031			1800/0.038		
		Evaporator Air—Ewb (F)								
		62	67	72	62	67	72	62	67	72
75	TC	47.6	52.5	56.2	49.4	53.6	57.0	50.6	54.5	57.5
	SHC	42.5	35.2	27.3	46.1	37.3	28.4	49.4	39.3	29.4
	kW	4.4	4.4	4.5	4.4	4.5	4.5	4.4	4.5	4.5
85	TC	45.0	50.6	54.8	46.6	51.8	55.7	48.0	52.8	56.5
	SHC	41.3	34.6	27.0	44.9	37.1	28.2	48.0	39.2	29.4
	kW	4.8	4.9	4.9	4.8	4.9	5.0	4.8	4.9	5.0
95	TC	42.5	48.0	52.8	44.0	49.3	53.9	45.8	50.3	54.7
	SHC	40.1	33.6	26.4	43.4	36.1	27.7	45.7	38.6	29.0
	kW	5.2	5.3	5.4	5.3	5.3	5.4	5.3	5.4	5.5
105	TC	40.0	45.2	50.6	41.7	46.4	51.5	43.6	47.5	52.3
	SHC	38.8	32.4	25.6	41.7	35.0	27.1	43.6	37.5	28.4
	kW	5.7	5.9	5.9	5.8	5.9	5.9	5.8	5.9	6.0
115	TC	36.7	41.4	47.0	38.9	42.6	48.1	40.6	43.5	49.0
	SHC	36.7	30.8	24.3	38.8	33.4	25.9	40.6	36.0	27.5
	kW	6.4	6.5	6.6	6.5	6.6	6.7	6.5	6.6	6.7
125	TC	33.8	37.5	43.2	35.7	38.7	44.2	37.5	39.6	45.1
	SHC	33.8	29.2	22.9	35.7	31.9	24.5	37.5	34.4	26.1
	kW	7.1	7.3	7.4	7.2	7.3	7.4	7.3	7.4	7.4

PA4E48 COOLING PERFORMANCE TABLE - SI										
Temp (°C) Outdoor Air Entering Condenser		Evaporator Air—L/s—BF								
		661/0.024			755/0.031			850/0.038		
		Evaporator Air—Ewb (°C)								
		17	19	22	17	19	22	17	19	22
24	TC	13.9	15.4	16.5	14.5	15.7	16.7	14.8	16.0	16.8
	SHC	12.5	10.3	8.0	13.5	10.9	8.3	14.5	11.5	8.6
	kW	4.4	4.4	4.5	4.4	4.5	4.5	4.4	4.5	4.5
29	TC	13.2	14.8	16.0	13.7	15.2	16.3	14.1	15.5	16.5
	SHC	12.1	10.1	7.9	13.1	10.9	8.3	14.1	11.5	8.6
	kW	4.8	4.9	4.9	4.8	4.9	5.0	4.8	4.9	5.0
35	TC	12.5	14.1	15.5	12.9	14.4	15.8	13.4	14.7	16.0
	SHC	11.7	9.8	7.7	12.7	10.6	8.1	13.4	11.3	8.5
	kW	5.2	5.3	5.4	5.3	5.3	5.4	5.3	5.4	5.5
41	TC	11.7	13.2	14.8	12.2	13.6	15.1	12.8	13.9	15.3
	SHC	11.4	9.5	7.5	12.2	10.3	7.9	12.8	11.0	8.3
	kW	5.7	5.9	5.9	5.8	5.9	5.9	5.8	5.9	6.0
46	TC	10.8	12.1	13.8	11.4	12.5	14.1	11.9	12.7	14.4
	SHC	10.8	9.0	7.1	11.4	9.8	7.6	11.9	10.5	8.0
	kW	6.4	6.5	6.6	6.5	6.6	6.7	6.5	6.6	6.7

See Legend and Notes following.

LEGEND

BF— Bypass Factor
 edb— Entering Dry—Bulb
 Ewb— Entering Wet—Bulb
 kW — Total Unit Power Input
 SHC— Sensible Heat Capacity (1000 Btuh)
 TC — Total Capacity (1000 Btuh) (net)

COOLING NOTES:

1. Ratings are net; they account for the effects of the evaporator—fan motor power and heat.
2. Direct interpolation is permissible. Do not extrapolate.
3. The following formulas may be used:

$$C_{ldb} = C_{edb} - \frac{SHC_{kW} \times 1000}{1.23 \times L/s}$$

Leaving wet bulb = wet bulb temperature corresponding to enthalpy of air leaving coil (h_{wb}).

$$h_{wb} = h_{ewb} - \frac{TC_{kW} \times 1000}{1.20 \times L/s}$$

Where h_{ewb} is enthalpy of air entering indoor coil.

SHC is based on 26.7 C db temperature of air entering the unit. At any other temperature, correct the SHC read from the table of cooling capacities as follows:

$$\text{Corrected } SHC_{kW} = SHC + [1.23 \times 10^{-3} \times (1-BF) \times (C_{db} - 26.7) \times L/s]$$

Above 26.7 C, SHC correction is positive; add it to SHC. Below 26.7 C, SHC correction is negative; subtract it from SHC.

PERFORMANCE DATA (CONT)

Economizer 1-in. (25 mm) Filter Pressure Drop

UNIT PA4E	PRESSURE DROP (in. W.C.)	PRESSURE DROP (Pa)
24-36	0.20	49.8
48	0.25	62.2

Electric Heater Multiplication Factors

HEATER KW RATING	VOLTAGE DISTRIBUTION V/3/60	MULTIPLICATION FACTOR
400	380	.90
	400	1.00
	415	1.08
	420	1.10

Example: 12.1 kW (at 400 v) heater on 380 v
 = 12.1 (.90 multiplication factor)
 = 10.9 kW capacity at 380 v

NOTE: Heater kW rating is voltage as marked on the base unit nameplate. Voltage distribution is the design power supply at installation site.

Wet Coil Air Delivery Horizontal and Downflow Discharge* PA4E (50 Hz) 24-48 (English)

400 VOLT													
UNIT	MOTOR SPEED	EXTERNAL STATIC PRESSURE (in. W.C.)											
		0.0	0.1	0.2	0.3	0.4	0.5	0.6	0.7	0.8	0.9	1.0	
PA4E24	Low	Watts	303	305	306	300	—	—	—	—	—	—	—
		Cfm	969	879	785	687	—	—	—	—	—	—	—
	High	Watts	—	—	—	—	435	428	428	422	—	—	—
		Cfm	—	—	—	—	963	833	758	676	—	—	—
PA4E30	Low	Watts	—	1002	954	921	889	853	814	—	—	—	—
		Cfm	—	1189	1115	1041	971	903	833	—	—	—	—
	High	Watts	—	—	—	—	—	—	—	700	683	688	755
		Cfm	—	—	—	—	—	—	—	1223	1142	1075	1058
PA4E36	Low	Watts	552	540	529	523	514	480	—	—	—	—	—
		Cfm	1296	1237	1167	1097	1029	952	—	—	—	—	—
	High	Watts	—	—	—	—	—	782	765	736	721	780	1002
		Cfm	—	—	—	—	—	1467	1398	1321	1237	1165	1137
PA4E48	Low	Watts	692	686	678	664	652	664	736	—	—	—	—
		Cfm	1571	1509	1444	1370	1295	1240	1237	—	—	—	—
	High	Watts	—	—	1112	930	856	834	825	811	793	—	—
		Cfm	—	—	1693	1670	1601	1521	1447	1378	1294	—	—

*Air delivery values are based on operating voltage of 400-v, wet coil, without filter or electric heater. Deduct filter and electric heater pressure drops to obtain static pressure available for ducting.

NOTES: 1. Do not operate the unit at a cooling airflow that is less than 350 cfm for each 12,000 Btuh (165 L/s for each 3.5 kW) of rated cooling capacity. Evaporator coil frosting may occur at airflow below this point.

2. Dashes indicate portions of table that are beyond the blower motor capacity or are not recommended.

Wet Coil Air Delivery Horizontal and Downflow Discharge* PA4E (50 Hz) 24-48 (SI)

400 VOLT													
UNIT	MOTOR SPEED	EXTERNAL STATIC PRESSURE (Pa)											
		0	25	50	75	100	125	150	175	200	225	250	
PA4E24	Low	Watts	303	305	303	300	—	—	—	—	—	—	—
		L/s	458	415	371	324	—	—	—	—	—	—	—
	High	Watts	—	—	—	—	435	428	428	422	—	—	—
		L/s	—	—	—	—	455	393	358	319	—	—	—
PA4E30	Low	Watts	—	1002	954	921	889	853	814	—	—	—	—
		L/s	—	561	526	491	458	426	393	—	—	—	—
	High	Watts	—	—	—	—	—	—	—	700	683	688	755
		L/s	—	—	—	—	—	—	—	577	539	508	499
PA4E36	Low	Watts	552	540	529	523	514	480	—	—	—	—	—
		L/s	612	584	551	518	486	449	—	—	—	—	—
	High	Watts	—	—	—	—	—	782	765	736	721	780	1002
		L/s	—	—	—	—	—	693	660	624	584	550	536
PA4E48	Low	Watts	692	686	678	664	652	664	736	—	—	—	—
		L/s	741	712	681	647	611	585	584	—	—	—	—
	High	Watts	—	—	1112	930	856	834	825	811	793	—	—
		L/s	—	—	799	788	756	718	683	650	611	—	—

*Air delivery values are based on operating voltage of 400-v, wet coil, without filter or electric heater. Deduct filter and electric heater pressure drops to obtain static pressure available for ducting.

NOTES: 1. Do not operate the unit at a cooling airflow that is less than 350 cfm for each 12,000 Btuh (165 L/s for each 3.5 kW) of rated cooling capacity. Evaporator coil frosting may occur at airflow below this point.

2. Dashes indicate portions of table that are beyond the blower motor capacity or are not recommended.

Filter Pressure Drop (IN. W.C.) (Pa)

FILTER SIZE in.	CFM																		
	500	600	700	800	900	1000	1100	1200	1300	1400	1500	1600	1700	1800	1900	2000	2100	2200	2300
20X20X1	0.05	0.07	0.08	0.10	0.12	0.13	0.14	0.15	—	—	—	—	—	—	—	—	—	—	—
20X24X1	—	—	—	—	0.09	0.10	0.11	0.13	0.14	0.15	0.16	—	—	—	—	—	—	—	—
24X30X1	—	—	—	—	—	—	—	0.07	0.08	0.09	0.10	0.11	0.12	0.13	0.14	0.15	0.16	0.17	0.18
FILTER SIZE mm	L/s																		
	236	283	330	378	425	472	519	566	614	661	707	755	802	850	896	944	991	1038	1085
508X508X25	12.4	17.4	19.9	24.9	29.9	32.3	34.8	37.3	—	—	—	—	—	—	—	—	—	—	—
508X610x25	—	—	—	—	22.4	24.9	27.4	32.3	34.8	37.4	39.9	—	—	—	—	—	—	—	—
610X762x25	—	—	—	—	—	—	—	17.4	19.9	22.4	24.9	27.4	29.9	32.3	34.8	37.3	39.8	42.3	44.6

Accessory Electric Heat Pressure Drop IN. W.C. (Pa)

HEATER kW	CFM									
	600	800	1000	1200	1400	1600	1800	2000	2200	
6.5–17.4	0.030	0.033	0.037	0.042	0.047	0.052	0.060	0.067	0.075	
	L/s									
	283	378	472	569	661	755	850	944	1038	
	7.5	8.2	9.2	10.4	11.7	12.9	14.9	16.7	18.7	

SUPERHEAT CHARGING TABLE (SUPERHEAT °C AT LOW-SIDE SERVICE PORT)															REQUIRED SUCTION TUBE TEMPERATURE °C (MEASURED AT LOW-SIDE SERVICE PORT)										
OUTDOOR TEMP. (°C)	ENTERING EVAPORATOR AIR °C WB														SUPERHEAT TEMP. (°C)	SUCTION PRESSURE AT SERVICE PORT (kPa)									
	10	11	12	13	14	15	16	17	18	19	20	21	22	23		24	743	774	805	836	869	902	957	971	1005
13	5.0	6.7	7.8	9.4	11.1	11.9	12.8	14.4	16.1	17.8	19.4	20.6	22.2	23.3	25.0	0	1.7	2.8	3.9	5.0	6.1	7.2	8.3	9.4	10.6
16	3.9	5.6	6.7	8.3	10.0	10.8	11.7	13.3	15.0	16.7	18.3	20.0	21.1	22.2	23.9	1	2.8	3.9	5.0	6.1	7.2	8.3	9.4	10.6	11.7
18	-	3.3	5.6	7.2	8.9	9.7	10.6	11.7	13.3	15.0	16.7	18.3	20.0	21.1	22.8	2	3.9	5.0	6.1	7.2	8.3	9.4	10.6	11.7	12.8
21	-	-	3.9	5.6	7.2	8.1	8.9	10.6	11.7	13.3	15.0	16.7	18.3	20.0	21.7	3	5.0	6.1	7.2	8.3	9.4	10.6	11.7	12.8	13.9
24	-	-	-	3.3	5.0	5.8	6.7	8.3	10.0	11.7	7.8	15.6	17.2	18.9	20.6	4	6.1	7.2	8.3	9.4	10.6	11.7	12.8	13.9	15.0
27	-	-	-	-	2.8	3.6	4.4	6.7	8.3	10.0	11.7	13.9	15.6	17.2	19.4	6	7.2	8.3	9.4	10.6	11.7	12.8	13.9	15.0	16.1
29	-	-	-	-	-	-	-	4.4	6.1	8.3	10.6	12.2	14.4	16.7	18.3	7	8.3	9.4	10.6	11.7	12.8	13.9	15.0	16.1	17.2
32	-	-	-	-	-	-	-	2.8	5.0	7.2	8.9	11.1	13.3	15.0	17.2	8	9.4	10.6	11.7	12.8	13.9	15.0	16.1	17.2	18.3
35	-	-	-	-	-	-	-	-	3.3	5.6	7.8	10.0	12.2	13.9	16.1	9	10.6	11.7	12.8	13.9	15.0	16.1	17.2	18.3	19.4
38	-	-	-	-	-	-	-	-	-	4.4	6.7	8.3	11.1	12.8	15.0	10	11.7	12.8	13.9	15.0	16.1	17.2	18.3	19.4	20.6
41	-	-	-	-	-	-	-	-	-	2.8	5.0	7.2	9.4	12.2	14.4	11	12.8	13.9	15.0	16.1	17.2	18.3	19.4	20.6	21.7
43	-	-	-	-	-	-	-	-	-	-	3.3	6.1	8.3	11.1	13.9	12	13.9	15.0	16.1	17.2	18.3	19.4	20.6	21.7	22.8
46	-	-	-	-	-	-	-	-	-	-	-	4.4	7.8	10.0	12.8	13	15.0	16.1	17.2	18.3	19.4	20.6	21.7	22.8	23.9
																14	16.1	17.2	18.3	19.4	20.6	21.7	22.8	23.9	25.0
																16	17.2	18.3	19.4	20.6	21.7	22.8	23.9	25.0	26.1
																17	18.3	19.4	20.6	21.7	22.8	23.9	25.0	26.1	27.2
																18	19.4	20.6	21.7	22.8	23.9	25.0	26.1	27.2	28.3
																19	20.6	21.7	22.8	23.9	25.0	26.1	27.2	28.3	29.4
																20	21.7	22.8	23.9	25.0	26.1	27.2	28.3	29.4	30.6
																21	22.8	23.9	25.0	26.1	27.2	28.3	29.4	30.6	31.7
																22	23.9	25.0	26.1	27.2	28.3	29.4	30.6	31.7	32.8

50ES500443 - 2.0

A09336

Fig. 1 – Cooling Charging Chart

TYPICAL PIPING AND WIRING

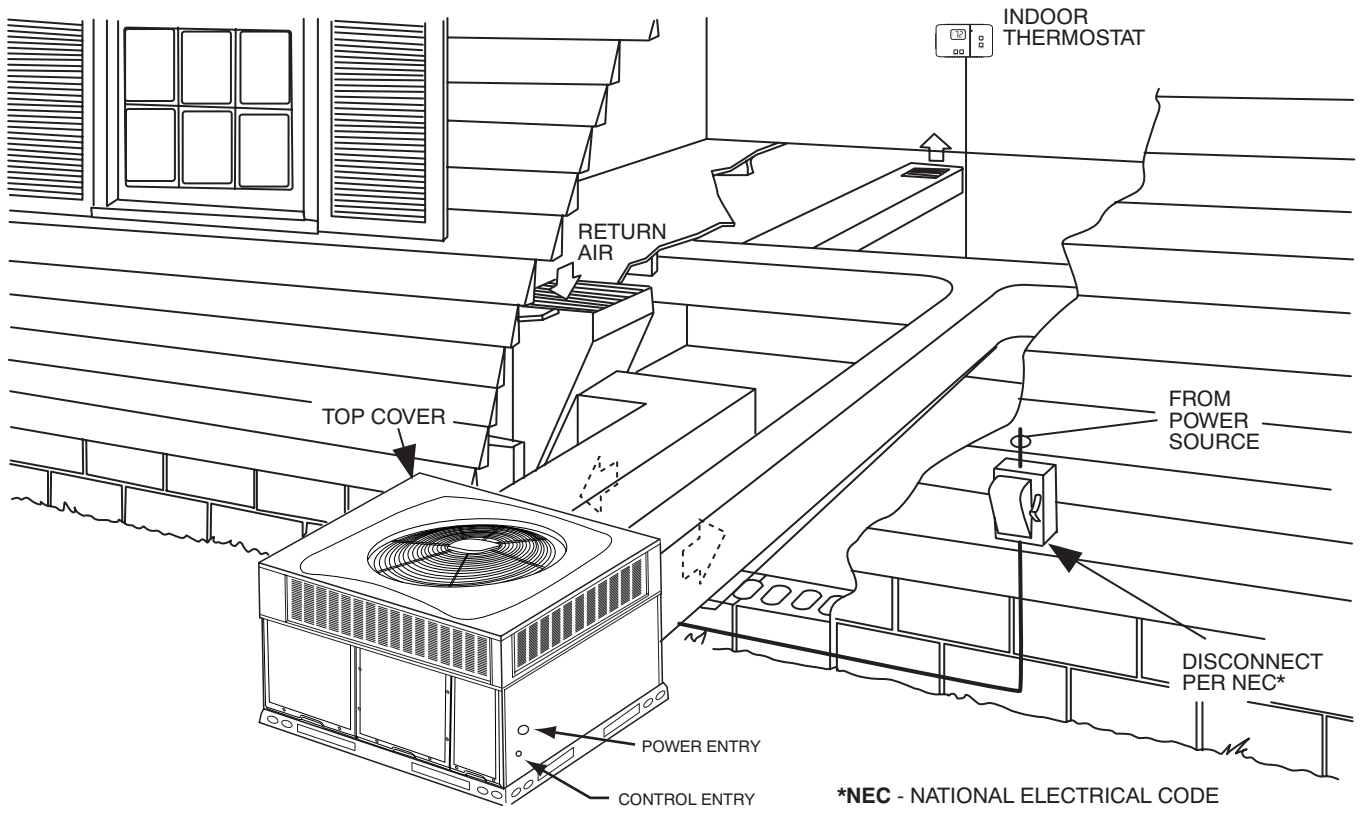

APPLICATION DATA

Condensate trap — A 2-in. (51 mm) condensate trap must be field supplied.

Ductwork — Secure downflow discharge ductwork to roof curb. For horizontal discharge applications, attach ductwork to unit with flanges.

To convert a unit to downflow discharge — Units are equipped with factory sealed covers in the downflow openings.

Maximum cooling airflow — To minimize the possibility of condensate blow-off from the evaporator, airflow through the units should not exceed 450 cfm per ton (60 L/s per kW).

Minimum cooling airflow — Minimum cooling airflow is 350 cfm per ton (46.8 L/s per kW).

Minimum ambient cooling operation temperature — All standard units have a minimum ambient operating temperature of 40°F (4°C). With accessory low ambient temperature kit, units can operate at temperatures down to 0°F (-17°C).

ELECTRICAL DATA

UNIT	NOMINAL	VOLTAGE RANGE		COMPRESSOR		OFM	IFM	ELECTRIC HEAT		POWER SUPPLY	
		MIN	MAX	RLA	LRA	FLA	FLA	NOMINAL kW	FLA	MCA	MOCP
PA4E24	400-3-50	380	420	4.5	32.0	0.8	1.1	—	—	7.5	15
								6.5	9.4	13.1	15
								8.7	12.6	12.1	20
PA4E30	400-3-50	380	420	5.2	35.0	0.8	1.7	—	—	9.0	15
								6.5	9.4	13.9	15
								8.7	12.6	17.9	20
PA4E36	400-3-50	380	420	6.5	46.0	0.8	2.0	—	—	10.9	15
								6.5	9.4	14.3	15
								8.7	12.6	18.3	20
PA4E48	400-3-50	380	420	6.7	50.0	1.3	3.9	—	—	13.6	20
								6.5	9.4	16.6	20
								8.7	12.6	20.6	25
								13.0	18.8	28.4	30
								17.4	25.1	36.3	40

LEGEND

FLA --- Full Load Amps
 LRA --- Locked Rotor Amps
 MCA --- Minimum Circuit Amps
 MOCP --- Maximum Overcurrent Protection
 RLA --- Rated Load Amps

NOTES:

- In compliance with NEC (National Electrical Code) requirements for multimotor and combination load equipment (refer to NEC Articles 430 and 440), the overcurrent protective device for the unit shall be Power Supply fuse. The CGA (Canadian Gas Association) units may be fuse or circuit breaker.
- Minimum wire size is based on 60°C copper wire. If other than 60°C wire is used, or if length exceeds wire length in table, determine size from NEC.
- Unbalanced 3-Phase Supply Voltage
 Never operate a motor where a phase imbalance in supply voltage is greater than 2%. Use the following formula to determine the percentage of voltage imbalance.

% Voltage imbalance

$$= 100 \times \frac{\text{max voltage deviation from average voltage}}{\text{average voltage}}$$

IMPORTANT: If the supply voltage phase imbalance is more than 2%, contact your local electric utility company immediately.

A06564

TYPICAL WIRING SCHEMATIC 400-3-50

SCHEMATIC
400-3-50

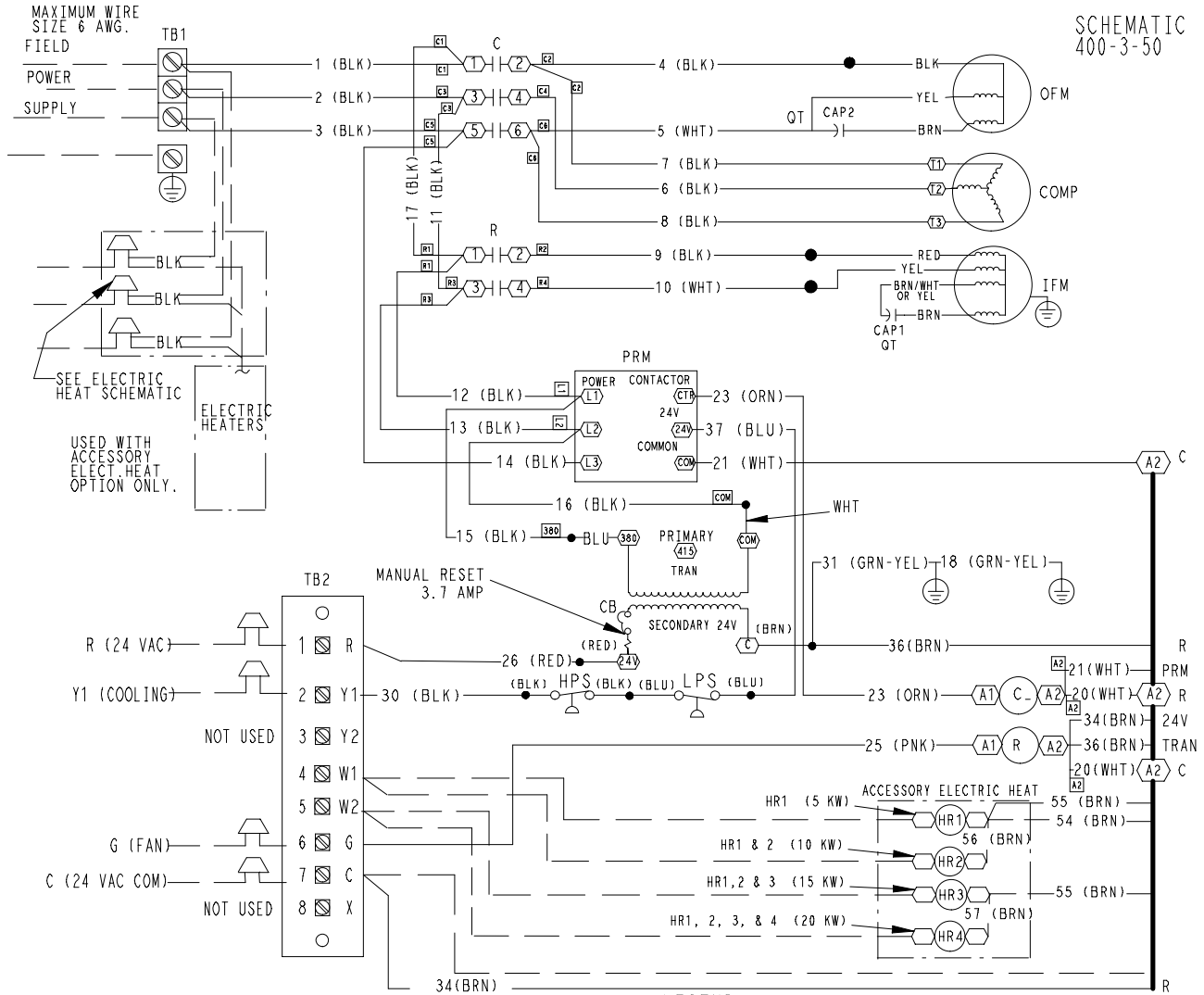

LEGEND

△	FIELD SPLICE	C	CONTACTOR
○	TERMINAL (MARKED)	CAP	CAPACITOR
○	TERMINAL (UNMARKED)	CB	CIRCUIT BREAKER
○	SPLICE	COMP	COMPRESSOR MOTOR
○	SPLICE (MARKED)	EQUIP	EQUIPMENT
---	FACTORY WIRING	GND	GROUND
---	FIELD CONTROL WIRING	HPS	HIGH PRESSURE SWITCH
---	FIELD POWER WIRING	HR	HEATER RELAY
---	ACCESSORY OR OPTIONAL WIRING	IFM	INDOOR FAN RELAY
---	TO INDICATE COMMON	IFM	INDOOR FAN MOTOR
---	POTENTIAL ONLY	LPS	LOW PRESSURE SWITCH
---	NOT TO REPRESENT WIRING	OFM	OUTDOOR FAN MOTOR
		PRM	PHASE ROTATION MONITOR
		QT	QUADRUPLE TERMINAL
		TC	THERMOSTAT-COOLING
		TH	THERMOSTAT-HEATING
		TRANS	TRANSFORMER
		TB1	TERMINAL BLOCK POWER LEADS
		TB2	TERMINAL BLOCK CONTROL LEADS

NOTES:

1. IF ANY OF THE ORIGINAL WIRES FURNISHED ARE REPLACED, IT MUST BE REPLACED WITH TYPE 90 DEGREE C WIRE OR IT'S EQUIVALENT.
2. USE 75 DEGREE COPPER CONDUCTORS FOR FIELD INSTALLATION.
3. FOR HIGH SPEED IFM, DISCONNECT RED WIRE FROM SPLICE AND CONNECT BLK WIRE FROM IFM. FOR MEDIUM SPEED (48 SIZE ONLY), DISCONNECT RED WIRE FROM SPLICE AND CONNECT BLU WIRE FROM IFM.

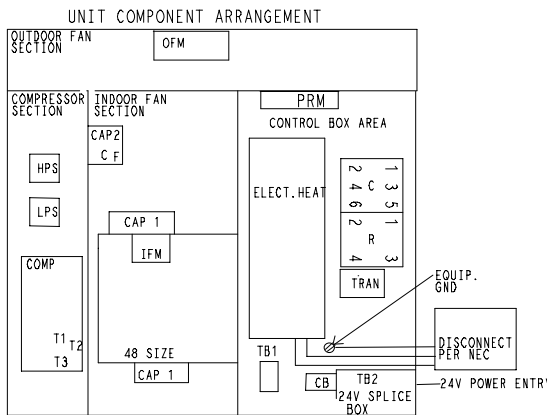

50GL500068 | 8.0

CONTROLS

Operating sequence

Cooling — When the system thermostat calls for cooling, 24 V is supplied to the “Y” and “G” terminals of the thermostat. This completes the circuit to the contactor coil (C) and indoor (evaporator) fan relay (IFR). The normally open contacts of energized C close and complete the circuit through compressor motor (COMP) to outdoor (condenser) fan motor (OFM). Both motors start instantly. The set of normally open contacts of energized IFR close and complete the circuit through IFM. The IFM starts instantly.

On the loss of the thermostat call for cooling, 24 V is removed from both the “Y” and “G” terminals (provided the fan switch is in the “AUTO” position) de-energizing the compressor contactor and opening the contacts supplying power to compressor/OFM. After a 90-second delay, the IFM shuts off. If the thermostat fan selector switch is in the “ON” position, the IFM will run continuously. For the 460 V units there is a step down autotransformer supplying 230 V to the Indoor Fan Motor.

NOTE: On units with a Time Guard® II device: Once the compressor has started and then stopped, it cannot be restarted again until 5 minutes have elapsed.

Heating — If accessory electric heaters are installed, on a call for heat, circuit R–W is made through the thermostat contacts. Circuit R–G is made which energizes the IFR. If the heaters are staged, then the thermostat closes a second set of contacts (W2) when second stage is required. When thermostat is satisfied, contacts open, deenergizing the heater relay and the IFR.

GUIDE SPECIFICATIONS

Packaged Air Conditioner System Constant Volume Application

HVAC Guide Specifications

Size Range: **2 to 4 Tons, Nominal Cooling**

Model Number: PA4E

Part 1 — General

SYSTEM DESCRIPTION

Outdoor rooftop mounted or ground mounted, electric cooling unit utilizing a hermetic scroll compressor for cooling duty. Unit shall discharge supply air vertically or horizontally as shown on contract drawings. Condenser fan/coil section shall have a draw-thru design with vertical discharge for minimum sound levels.

QUALITY ASSURANCE

B. Unit shall be tested in accordance with ARI Standards 210/240 and 270.

C. Unit shall be designed in accordance with UL Standard 1995 and EN 60335-1.

D. Roof curb shall be designed to conform to NRCA Standards.

E. Insulation and adhesives shall meet NFPA 90A requirements for flame spread and smoke generation.

F. Cabinet insulation shall meet ASHRAE Standard 62P.

DELIVERY, STORAGE AND HANDLING

Unit shall be stored and handled per manufacturer's recommendations.

Part 2 — Products

EQUIPMENT

A. General:

Factory-assembled, single-piece, heating and cooling unit. Contained within the enclosure shall be all factory wiring, piping, controls, refrigerant charge with R-410A refrigerant, and special features required prior to field start-up.

B. Unit Cabinet:

1. Unit cabinet shall be constructed of phosphated, zinc-coated, pre-painted steel capable of with-standing 500 hours in salt spray.
2. Normal service shall be through three-panel accessibility.
3. The unit shall be constructed on a rust resistant unit base that has an externally trapped, integrated sloped drain.

4. Evaporator fan compartment top surface shall be insulated with a minimum 1/2-in. (12.7 mm) thick, flexible fiberglass insulation, coated on the air side and retained by adhesive and mechanical means. The evaporator wall sections will be insulated with a minimum semi-rigid foil-faced board capable of being wiped clean. Aluminum foil-faced fiberglass insulation shall be used in the entire indoor air cavity section.

5. Unit shall have a field-supplied condensate trap.

C. Fans:

1. The evaporator fan shall be direct-drive multi-speed motor and control, as shown on equipment drawings.
2. Fan wheel shall be made from steel, be double-inlet type with forward curved blades with corrosion resistant finish. Fan wheel shall be dynamically balanced.
3. Condenser fan shall be direct drive propeller type with aluminum blades riveted to corrosion resistant steel spiders, be dynamically balanced, and discharge air vertically.

D. Compressor:

1. Fully hermetic compressors with factory-installed vibration isolation.
2. Scroll compressors shall be standard on all units.

E. Coils:

Evaporator and condenser coils shall have aluminum plate fins mechanically bonded to seamless copper tubes with all joints brazed. Tube sheet openings shall be belled to prevent tube wear.

F. Refrigerant Components:

Refrigerant expansion device shall be of the fixed orifice type.

G. Filters:

Filter section shall consist of field-installed, throwaway, 1-in. (25 mm) thick fiberglass filters of commercially available sizes.

GUIDE SPECIFICATIONS (CONT)

H. Controls and Safeties:

1. Unit controls shall be complete with a self-contained low voltage control circuit.
2. Compressors shall incorporate a solid-state compressor protector that provides reset capability.

I. Operating Characteristics:

1. Unit shall be capable of starting and running at 125°F (51°C) ambient outdoor temperature (except 48 size shall be capable of starting and running at 115°F (46°C)).
2. Compressor with standard controls shall be capable of operation down to 40°F (4°C) ambient outdoor temperature.
3. Units shall be provided with fan time delay to prevent cold air delivery before the heat exchanger warms up.

J. Electrical Requirements:

All unit power wiring shall enter the unit cabinet at a single location.

K. Motors:

1. Compressor motors shall be of the refrigerant-cooled type with line-break thermal and current overload protection.
2. All fan motors shall have permanently lubricated bearings, and inherent, automatic reset, thermal overload protection.

L. Special Features:

1. Electric Heaters:
 - a. Electric heater shall be available as a field-installed option.

- b. Heater elements shall be open wire type, adequately supported and insulated with ceramic bushings.

- c. Electric heater packages must provide single point power connection capability.

2. Filter Rack Kit:

Shall provide filter mounting for downflow applications.

3. Flat Roof Curb:

Curbs shall have seal strip and a wood nailer for flashing and shall be installed per manufacturer's instructions.

4. Low Ambient Package:

Shall consist of a solid-state control and condenser coil temperature sensor for controlling condenser-fan motor operation, which shall allow unit to operate down to 0°F (17.7°C) outdoor ambient temperature when properly installed.

5. Manual Outdoor Air Damper:

Package shall consist of damper, birdscreen, and rainhood which can be preset to admit outdoor air for year-round ventilation.

6. Square-To-Round Duct Transitions (24-48 size):

Shall have the ability to convert the supply and return openings from rectangular to round.

7. Anti-Cycle Timer

Automatically prevents the compressor from restarting for at least 4 minutes and 45 seconds after shutdown of the compressor. Not required when a corporate programmable thermostat is applied.