

Parts List, Tech Labels, Wiring Diagrams

Models

Three Phase
208-230, 460, 600 Volt

PGD090H200A	GPD090H200A
PGD090L200A	GPD090L200A
PGD090S200B	GPD090S200B
PGD120H240A	GPD120H240A
PGD120L240A	GPD120L240A
PGD120S240B	GPD120S240B
PGD150H270A	GPD150H270A
PGD150L270A	GPD150L270A
PGD150S270B	GPD150S270B
PGD180H270A	GPD180H270A
PGD180L270A	GPD180L270A
PGD180S270B	GPD180S270B

Commercial Package Gas/Electric Units

Manufactured by:
International Comfort Products Corporation (USA)
Lewisburg, TN USA 37091

Save This Manual For Future Reference

Parts List MODELS: PGD090H200, PGD090L200,PGD090S200, PGD120H240, PGD120L240, PGD120S240, PGD150H270, PGD150L270, PGD150S270, PGD180H270, PGD180L270, PGD180S270, GPD090H270, GPD090L270, GPD090S270, GPD120H270, GPD120L270, GPD120S270, GPD150H270, GPD150L270, GPD150S270, GPD180H270, GPD180L270, GPD180S270

NO	DESCRIPTION	PART NUMBER	MODEL SIZE & VOLTAGE											
			090H	090L	090S	120H	120L	120S	150H	150L	150S	180H	180L	180S
1	Compressor, ZR40K3TF5	1096240	2											
1	Compressor, ZR40K3TFD	1096758	*	2										
1	Compressor, ZR40K3TFE	1096775	*	*	2									
1	Compressor, ZR61KCTF5	1084537	*	*	*	2								
1	Compressor, ZR61KCTFD	1085397	*	*	*	*	2							
1	Compressor, ZR61KCTFE	1096776	*	*	*	*	*	2						
1	Compressor, ZR72KCTF5	1096586	*	*	*	*	*	*	2			1		
1	Compressor, ZR72KCTFD	1096781	*	*	*	*	*	*	*	2			1	
1	Compressor, ZR72KCTFE	1096782	*	*	*	*	*	*	*	*	2			1
2	Motor, Condenser Fan 1/230 3/4	1070461	1			2			2			2		
2	Motor, Condenser Fan 1/460 3/4	1070466	*	1			2			2			2	
2	Motor, Condenser Fan 1/575 3/4	1070471	*	*	1			2			2			2
3	Fan, Condenser	1080797	1	1	1				2	2	2	2	2	2
3	Fan, Condenser	1080799	*	*	*	2	2	2						
4	Coil, Evaporator	1096524	*	*	*	*	*	*	*	*	*	1	1	1
4	Coil, Evaporator	1096638	*	*	*	*	*	*	1	1	1			
4	Coil, Evaporator	1096740	*	*	*	1	1	1						
4	Coil, Evaporator	1096748	1	1	1									
5	Manifold, Evaporator (Liquid)	1096532	*	*	*	*	*	*	*	*	*	1	1	1
5	Manifold, Evaporator (Liquid)	1096645	*	*	*	*	*	*	1	1	1			
5	Manifold, Evaporator (Liquid)	1096741	*	*	*	1	1	1						
5	Manifold, Evaporator (Liquid)	1096746	1	1	1									
6	Manifold, Evaporator (Liquid)	1096533	*	*	*	*	*	*	*	*	*	1	1	1
6	Manifold, Evaporator (Liquid)	1096646	*	*	*	*	*	*	1	1	1			
6	Manifold, Evaporator (Liquid)	1096742	*	*	*	1	1	1						
6	Manifold, Evaporator (Liquid)	1096747	1	1	1									
7	Manifold, Evaporator (Upper)	1084308	*	*	*	1	1	1						
7	Manifold, Evaporator (Upper)	1096534	*	*	*	*	*	*	*	*	*	1	1	1
7	Manifold, Evaporator (Upper)	1096639	*	*	*	*	*	*	1	1	1			
7	Manifold, Evaporator (Upper)	1096750	1	1	1									
8	Manifold, Evaporator (Lower)	1084309	*	*	*	1	1	1						
8	Manifold, Evaporator (Lower)	1096535	*	*	*	*	*	*	*	*	*	1	1	1
8	Manifold, Evaporator (Lower)	1096644	*	*	*	*	*	*	1	1	1			
8	Manifold, Evaporator (Lower)	1096751	1	1	1									
9	Filter, Air 20x25x2"	85953	4	4	4	4	4	4						
9	Filter, Air 20x30x2"	1054503	*	*	*	*	*	*	4	4	4	4	4	4
10	Pan, Drain	1071339	1	1	1	1	1	1						
10	Pan, Drain	1083413	*	*	*	*	*	*	1	1	1	1	1	1
11	Grommet, Compressor Mounting	1052060	8	8	8	8	8	8	8	8	8	8	8	8
12	Plug, Compressor Harness	1085334	2	2	2	2	2	2						
12	Plug, Compressor Harness	1083654	*	*	*	*	*	*	2	2	2	2	2	2
13	Coil, Condenser	1096525	*	*	*	*	*	*	*	*	*	1	1	1
13	Coil, Condenser	1096688	*	*	*	*	*	*	1	1	1			
13	Coil, Condenser	1096735	1	1	1									
13	Coil, Condenser	1097371	*	*	*	1	1	1						
14	Port Valve Assembly	1096778	2	2	2	2	2	2	2	2	2	2	2	2
15	Tube, W/Strainer	1096597	2	2	2	2	2	2	2	2	2	2	2	2
16	Switch, Freeze Stat.	1096710	2	2	2	2	2	2	2	2	2	2	2	2
17	Manifold, Condenser (Liquid)	1096545	*	*	*	*	*	*	2	2	2	2	2	2
17	Manifold, Condenser (Liquid)	1096731	1	1	1	1	1	1						
18	Manifold, Condenser (Discharge)	1096547	*	*	*	*	*	*	2	2	2	2	2	2
18	Manifold, Condenser (Discharge)	1096876	1	1	1	1	1	1						

NO	DESCRIPTION	PART NUMBER	MODEL SIZE & VOLTAGE											
			090H	090L	090S	120H	120L	120S	150H	150L	150S	180H	180L	180S
19	Manifold, Condenser (Liquid)	1096736	1	1	1	1	1	1						
20	Manifold, Condenser (Discharge)	1096874	1	1	1	1	1	1						
21	Switch, High Pressure	1096251	2	2	2	2	2	2	2	2	2	2	2	2
22	Switch, Low Pressure	1085492	2	2	2	2	2	2	2	2	2	2	2	2
23	Heat Exchanger	1071596	1	1	1									
23	Heat Exchanger	1071597	*	*	*	1	1	1						
23	Heat Exchanger	1071598	*	*	*	*	*	*	1	1	1	1	1	1
24	Turbulator, Outlet	1054516	6	6	6	7	7	7	8	8	8	8	8	8
25	Turbulator, Inlet	1083436	6	6	6	7	7	7	8	8	8	8	8	8
26	Gasket, Restrictor	1071166	1	1	1	1	1	1						
26	Gasket, Restrictor	1071167	*	*	*	*	*	*	1	1	1	1	1	1
27	Channel, Restrictor	1070754	1	1	1	1	1	1						
27	Channel, Restrictor	1070756	*	*	*	*	*	*	1	1	1	1	1	1
28	Ignitor	1070953	1	1	1	1	1	1	1	1	1	1	1	1
29	Sensor, Flame	1070952	1	1	1	1	1	1	1	1	1	1	1	1
30	Switch, Limit Rollout	1071238	1	1	1	1	1	1	1	1	1	1	1	1
31	Bracket, Burner Support	1070371	1	1	1	1	1	1						
31	Bracket, Burner Support	1070372	*	*	*	*	*	*	1	1	1	1	1	1
32	Burner	1070679	6	6	6	7	7	7	8	8	8	8	8	8
33	Bracket, Manifold	1070368	*	*	*	*	*	*	1	1	1	1	1	1
33	Bracket, Manifold	1070370	1	1	1	1	1	1						
34	Channel, Burner Support	1070374	1	1	1	1	1	1						
34	Channel, Burner Support	1070375	*	*	*	*	*	*	1	1	1	1	1	1
35	Orifice, Burner Nat. #34	1070700	6	6	6	7	7	7	8	8	8	8	8	8
36	Manifold, Gas	1070695	1	1	1									
36	Manifold, Gas	1070696	*	*	*	1	1	1						
36	Manifold, Gas	1070697	*	*	*	*	*	*	1	1	1	1	1	1
37	Valve, Gas Nat.	1070690	1	1	1	1	1	1	1	1	1	1	1	1
37	Valve, Gas L.P.	1071324	1	1	1	1	1	1	1	1	1	1	1	1
38	Tube, Pilot	1070685	1	1	1	1	1	1	1	1	1	1	1	1
39	Connector, Pilot	1070173	1	1	1	1	1	1	1	1	1	1	1	1
41	Crosslighter	1070680	1	1	1	1	1	1						
41	Crosslighter	1070682	*	*	*	*	*	*	1	1	1	1	1	1
42	Capacitor, 3 Mfd., 370 Volt	171521008	1	1	1	1	1	1	1	1	1	1	1	1
43	Tube, Sensor	1071343	1	1	1	1	1	1	1	1	1	1	1	1
44	Module, Ignition	1070955	1	1	1	1	1	1	1	1	1	1	1	1
45	Switch, Pressure	1071058	1	1	1	1	1	1	1	1	1	1	1	1
46	Blower, Exhaust Assembly	1070770	1	1	1	1	1	1	1	1	1	1	1	1
47	Gasket, Blower	1070762	2	2	2	2	2	2	2	2	2	2	2	2
48	Plate, Restrictor	1070240	1	1	1									
48	Plate, Restrictor	1070241	*	*	*	1	1	1						
48	Plate, Restrictor	1070242	*	*	*	*	*	*	1	1	1	1	1	1
49	Box, Collector	1070364	1	1	1	1	1	1						
49	Box, Collector	1070365	*	*	*	*	*	*	1	1	1	1	1	1
50	Gasket, Collector	1070759	1	1	1	1	1	1						
50	Gasket, Collector	1070760	*	*	*	*	*	*	1	1	1	1	1	1
51	Switch, Limit High	1071387	1	1	1	1	1	1	1	1	1	1	1	1
52	Block, Terminal	170720	1	1	1	1	1	1	1	1	1	1	1	1
53	Timer, Compressor Anti-Cycle	1085325	2	2	2	2	2	2	2	2	2	2	2	2
54	Relay, SPDT	1058148	2	2	2	2	2	2	2	2	2	2	2	2
55	Relay, DPST	1000742	1	1	1	1	1	1	1	1	1	1	1	1
56	Capacitor, 12.5 Mfd., 440 Volt	1094967	1	1	1	2	2	2	2	2	2	2	2	2
57	Contact, 40 Amp., 3 Pole	1071334	1	1	1	1	1	1	1	1	1	1	1	1
58	Contact, 40 Amp., 3 Pole	1071334	1	1	1	1	1	1	1	1	1	1	1	1
59	Board, Terminal	1066159	1	1	1	1	1	1	1	1	1	1	1	1
60	Lug, Ground	500920	1	1	1	1	1	1	1	1	1	1	1	1

NO	DESCRIPTION	PART NUMBER	MODEL SIZE & VOLTAGE											
			090H	090L	090S	120H	120L	120S	150H	150L	150S	180H	180L	180S
62	Contactora, 30 Amp., 2 Pole	1054736	1	1	2	1	1	2	1	1	2	1	1	2
63	Transformer, 230V, 65VA	1054637	1			1			1			1		
63	Transformer, 460-575V, 100VA	1054639	*	1	1		1	1		1	1		1	1
64	Timer, Blower Time Delay	1071063	1	1	1	1	1	1	1	1	1	1	1	1
64	Transformer, 460-575V, 65VA	1054638	*	*	1			1			1			1
64	Transformer, 460V, 75VA	1084001	*	1			1			1			1	
65	Motor, Blower, 230/460V, 2HP	1070644	1	1		1	1							
65	Motor, Blower, 230/460V, 3HP	1070646	*	*	*	*	*	*	1	1			1	1
65	Motor, Blower, 575V, 2HP	1070654	*	*	1			1						
65	Motor, Blower, 575V, 3HP	1070656	*	*	*	*	*	*	*	*	1			1
66	Pulley, Blower	1097228	1	1	1									
66	Pulley, Blower	1097293	*	*	*	1	1	1						
66	Pulley, Blower	1097294	*	*	*	*	*	*	1	1	1	1	1	1
67	Belt	1070670	*	*	*	*	*	*	1	1	1	1	1	1
67	Belt	1097236	1	1	1	1	1	1						
68	Pulley, Motor	520290	*	*	*	*	*	*	1	1	1	1	1	1
68	Pulley, Motor	1097240	1	1	1	1	1	1						
69	Blower	1070639	1	1	1	1	1	1						
69	Blower	1070641	*	*	*	*	*	*	1	1	1	1	1	1
70	Switch, Auxiliary Limit	1071246	1	1	1	1	1	1	1	1	1	1	1	1
P	Shield, Heat	1070377	1	1	1	1	1	1						
)	Wire Assembly, RSPS	1071188	1	1	1	1	1	1	1	1	1	1	1	1
)	Wire Assembly, Sensor	1071242	1	1	1	1	1	1	1	1	1	1	1	1
)	Wire, Assembly, MLRS	1071230	1	1	1	1	1	1	1	1	1	1	1	1
)	Wire, Ignitor	1071149	1	1	1	1	1	1	1	1	1	1	1	1
1A	Compressor, ZR94KCTF5	1096587	*	*	*	*	*	*	*	*	*	1		
1A	Compressor, ZR94KCTFD	1096779	*	*	*	*	*	*	*	*	*	*	1	
1A	Compressor, ZR94KCTFE	1096780	*	*	*	*	*	*	*	*	*	*	*	1
A	Grille, Outlet	1072841	1	1	1				2	2	2	2	2	2
A	Grille, Outlet	1072842	*	*	*	2	2	2						
A1	Nut, Cap	1067902	4	4	4	8	8	8	8	8	8	8	8	8
AA	Post, Drain Outlet	1096509	1	1	1	1	1	1						
AA	Post, Drain Outlet	1096539	*	*	*	*	*	*	1	1	1	1	1	1
AB	Screw, Motor Adjust 3/8-16	1071172	1	1	1	1	1	1	1	1	1	1	1	1
AC	Bracket, Motor Mount	1070361	1	1	1	1	1	1	1	1	1	1	1	1
AD	Mount, Blower Motor	1071248	1	1	1	1	1	1	1	1	1	1	1	1
AE	Clip, Retaining	1071304	1	1	1	1	1	1	1	1	1	1	1	1
AF	Bracket, Blower Support	1071239	1	1	1	1	1	1	1	1	1	1	1	1
B	Panel, Top Heat	1072779	*	*	*	*	*	*	1	1	1	1	1	1
B	Panel, Top Heat	1072780	1	1	1	1	1	1						
BB	Post, Condenser Front	1084005	1	1	1	1	1	1						
BB	Post, Condenser Front	1084454	*	*	*	*	*	*	1	1	1	1	1	1
C	Panel, Top Evaporator	1072831	*	*	*	*	*	*	1	1	1	1	1	1
C	Panel, Top Evaporator	1072832	1	1	1	1	1	1						
CC	Rail, Base Front	****												
D	Support, Condenser Top	1071296	1	1	1	1	1	1	1	1	1	1	1	1
DD	Post, Condenser Front	1084345	1	1	1	1	1	1						
DD	Post, Condenser Front	1084410	*	*	*	*	*	*	1	1	1	1	1	1
E	Panel, Top Condenser	1072837	1	1	1									
E	Panel, Top Condenser	1072840	*	*	*	1	1	1						
E	Panel, Top Condenser	1072839	*	*	*	*	*	*	1	1	1	1	1	1
EE	Rail, Base Condenser End	****												
F	Orifice, Condenser Fan	1065725	*	*	*	2	2	2						
F	Orifice, Condenser Fan	1070458	1	1	1				2	2	2	2	2	2
FF	Support, Compressor	****												

NO	DESCRIPTION	PART NUMBER	MODEL SIZE & VOLTAGE											
			090H	090L	090S	120H	120L	120S	150H	150L	150S	180H	180L	180S
G	Panel, Division (Cond/Evap)	****	*	*	*	1	1	1						
G	Panel, Division (Cond/Evap)	****	*	*	*	*	*	*	1	1	1	1	1	1
G	Panel, Division (Cond/Evap)	****	1	1	1									
GG	Panel, Base Condenser	****	1	1	1	1	1	1						
GG	Panel, Base Condenser	****	*	*	*	*	*	*	1	1	1	1	1	1
H	Panel, Supply Air	1085335	1	1	1	1	1	1						
H	Panel, Supply Air	1096701	*	*	*	*	*	*	1	1	1	1	1	1
HH	Post, Corner Condenser	1072754	1	1	1	1	1	1						
HH	Post, Corner Condenser	1072755	*	*	*	*	*	*	1	1	1	1	1	1
JJ	Rail, Base Rear	****												
K	Deck, Blower	1070288	1	1	1	1	1	1						
K	Deck, Blower	1070292	*	*	*	*	*	*	1	1	1	1	1	1
KK	Post, Condenser Rear	1084349	*	*	*	1	1	1						
KK	Post, Condenser Rear	1084387	*	*	*	*	*	*	*	*	*	1	1	1
KK	Post, Condenser Rear	1096562	1	1	1									
KK	Post, Condenser Rear	1096563	*	*	*	*	*	*	1	1	1			
L	Post, Corner Heat Front	1083177	*	*	*	*	*	*	1	1	1	1	1	1
L	Post, Corner Heat Front	1072758	1	1	1	1	1	1						
LL	Panel, Duct Cover (Return)	1072809	1	1	1	1	1	1						
LL	Panel, Duct Cover (Return)	1072812	*	*	*	*	*	*	1	1	1	1	1	1
M	Support, Flue	1070767	*	*	*	*	*	*	1	1	1	1	1	1
M	Support, Flue	1070766	1	1	1	1	1	1						
MM	Panel, Return Air	1072794	1	1	1	1	1	1						
MM	Panel, Return Air	1072795	*	*	*	*	*	*	1	1	1	1	1	1
N	Hood, Flue Exhaust	1070764	*	*	*	*	*	*	1	1	1	1	1	1
N	Hood, Flue Exhaust	1070763	1	1	1	1	1	1						
NN	Panel, Duct Cover (Supply)	1072810	*	*	*	*	*	*	1	1	1	1	1	1
NN	Panel, Duct Cover (Supply)	1072811	1	1	1	1	1	1						
O	Panel, Access (Heat)	1072829	1	1	1	1	1	1						
O	Panel, Access (Heat)	1072830	*	*	*	*	*	*	1	1	1	1	1	1
P	Shield, Heat	1070378	*	*	*	*	*	*	1	1	1	1	1	1
PP	Panel, Division (Evap/Heat)	****	1	1	1	1	1	1						
PP	Panel, Division (Evap/Heat)	****	*	*	*	*	*	*	1	1	1	1	1	1
Q	Panel, Component Mounting	1082321	*	*	*	*	*	*	1	1	1	1	1	1
Q	Panel, Component Mounting	1071138	1	1	1	1	1	1						
QQ	Pan, Base (Evap)	****	1	1	1	1	1	1						
QQ	Pan, Base (Evap)	****	*	*	*	*	*	*	1	1	1	1	1	1
R	Panel, Access (Blower)	1072802	1	1	1	1	1	1						
R	Panel, Access (Blower)	1072803	*	*	*	*	*	*	1	1	1	1	1	1
RR	Support, Coil	1070784	1	1	1	1	1	1						
S	Panel, Access (Burner)	1072804	1	1	1	1	1	1						
S	Panel, Access (Burner)	1072805	*	*	*	*	*	*	1	1	1	1	1	1
SS	Hose, Drain	1071345	1	1	1	1	1	1	1	1	1	1	1	1
T	Hood, Rain	1072817	1	1	1	1	1	1						
T	Hood, Rain	1072818	*	*	*	*	*	*	1	1	1	1	1	1
TT	Bracket, Filter Rack	1070993	2	2	2	2	2	2						
TT	Bracket, Filter Rack	1083434	*	*	*	*	*	*	1	1	1	1	1	1
U	Panel, Access (Evaporator)	1072788	1	1	1	1	1	1						
U	Panel, Access (Evaporator)													
UU	Bracket, Filter Rack	1083435	*	*	*	*	*	*	1	1	1	1	1	1
UU	Bracket, Filter Rack	1070516	1	1	1	1	1	1						
UU	Rack, Filter	1070516	1	1	1	1	1	1						
UU	Rack, Filter	1083129	*	*	*	*	*	*	1	1	1	1	1	1

NO	DESCRIPTION	PART NUMBER	MODEL SIZE & VOLTAGE												
			090H	090L	090S	120H	120L	120S	150H	150L	150S	180H	180L	180S	
V	Panel, Access (Condenser)	1072784	1	1	1	1	1	1							
V	Panel, Access (Condenser)														
V	Panel, Compressor Access	1084344	1	1	1	1	1	1							
V	Panel, Compressor Access	1085345	*	*	*	*	*	*	1	1	1	1	1	1	
w	Clamp, Capacitor	94364	1	1	1	1	1	1	1	1	1	1	1	1	
W	Extension, Exhaust	*****													
ww	Box, Control	1096696	1	1	1	1	1	1	1	1	1	1	1	1	
X	Rail, Base Heat End	*****													
XX	Clamp, Capacitor	1095022	1	1	1	2	2	2	2	2	2	2	2	2	
Y	Extension, Exhaust	*****													
YY	Bracket, Low Voltage	1066106	1	1	1	1	1	1	1	1	1	1	1	1	
Z	Pan, Base (Heat)	*****	1	1	1	1	1	1							
Z	Pan, Base (Heat)	*****	*	*	*	*	*	*	1	1	1	1	1	1	
	Panel, Filler	1084438	1	1	1	1	1	1							
	Panel, Filler	1096677	*	*	*	*	*	*	1	1	1	1	1	1	
	Panel, Filter Access	1096784	*	*	*	*	*	*	1	1	1	1	1	1	

Functional Parts

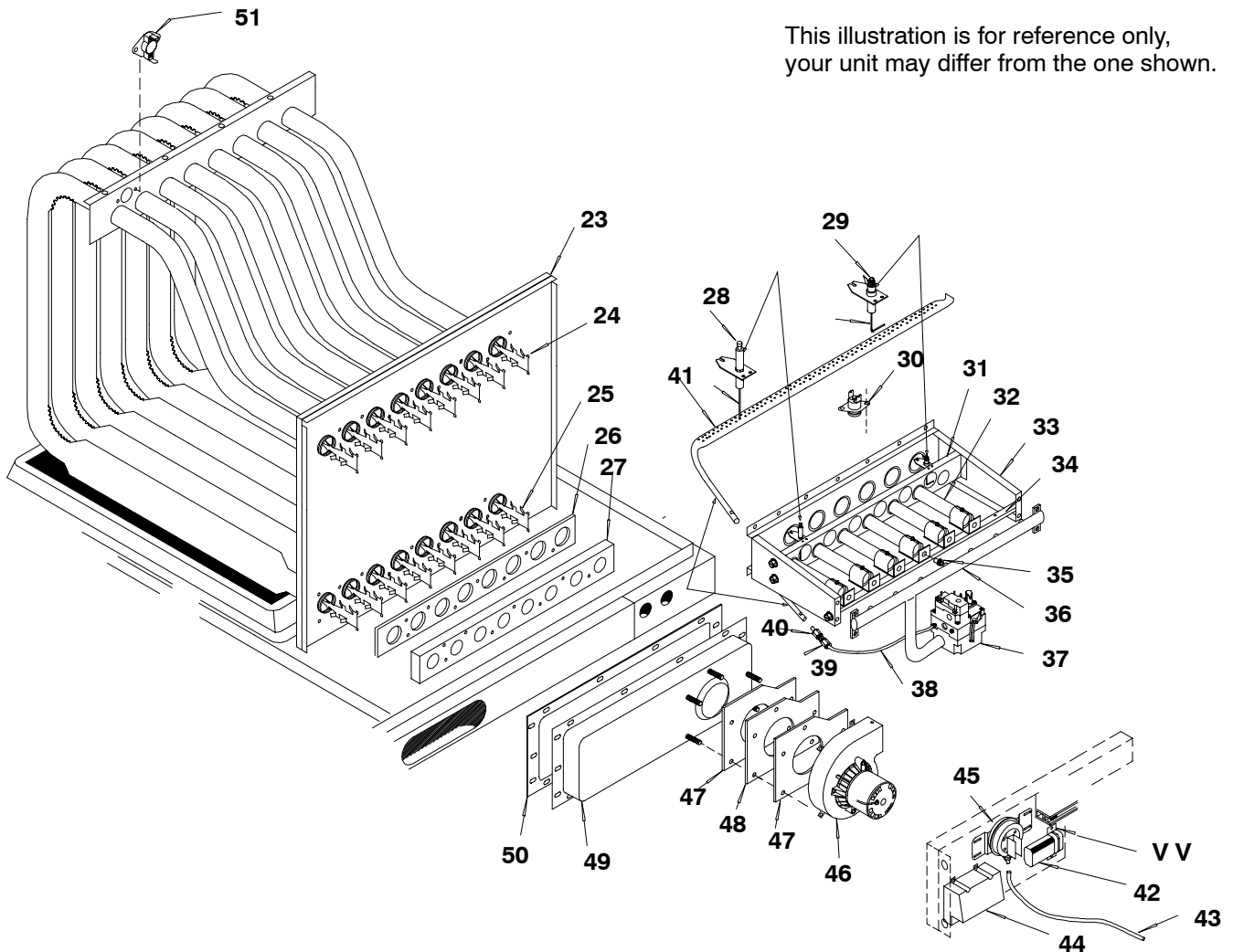

Functional Parts

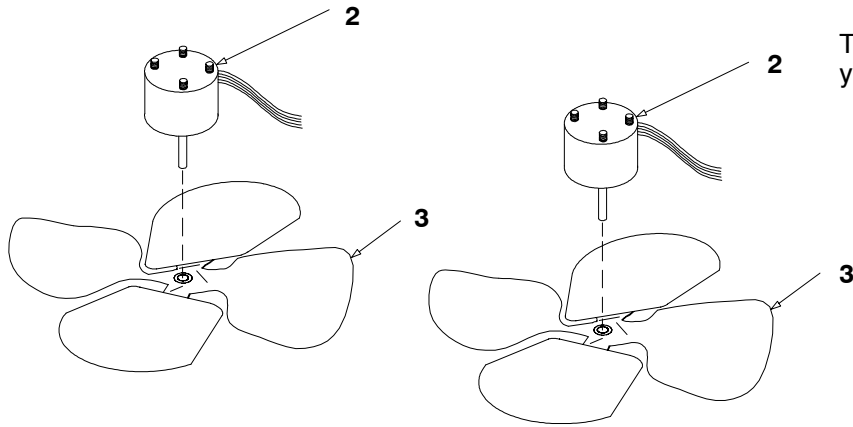

This illustration is for reference only, your unit may differ from the one shown.

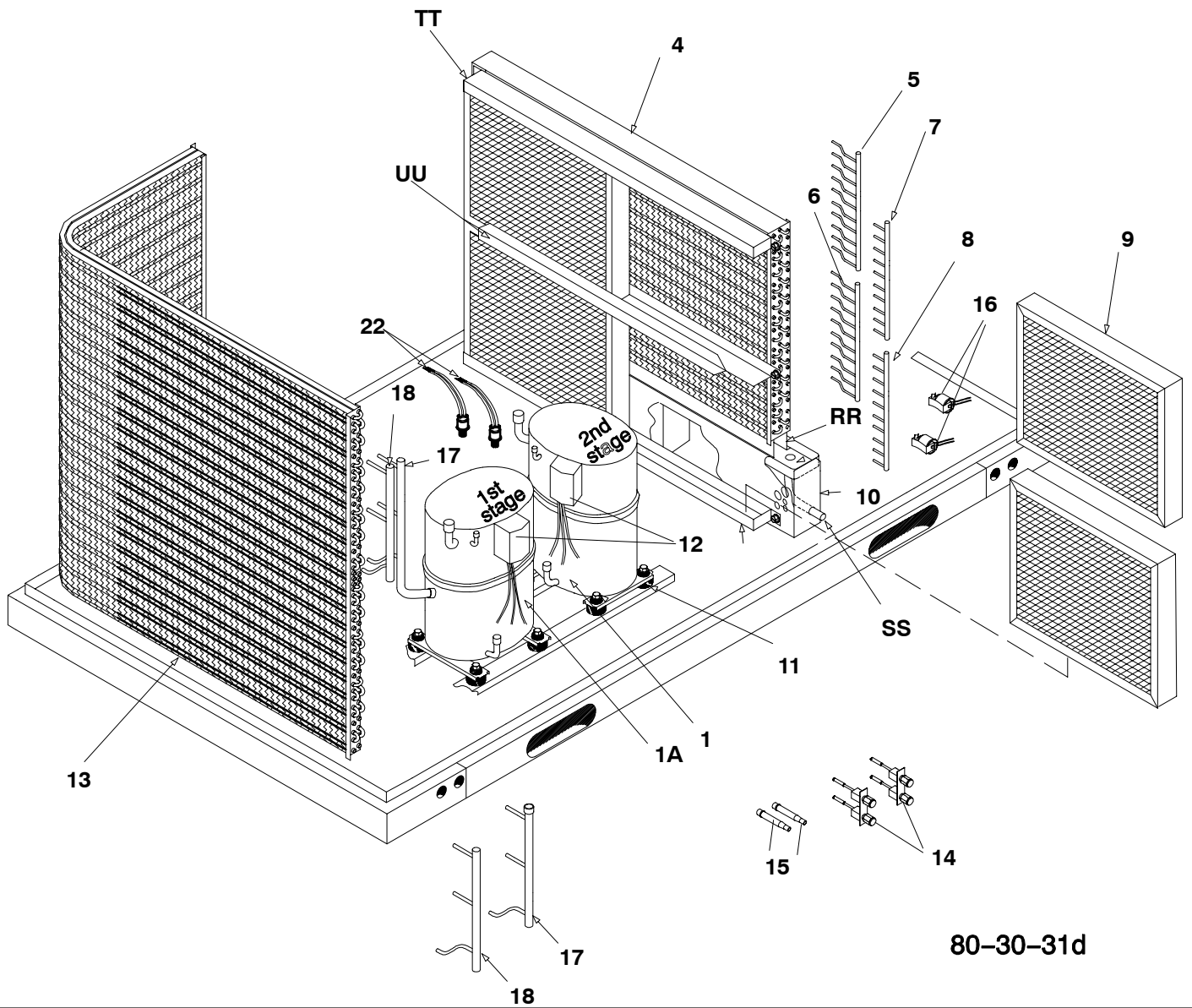

80-30-31d

Illustrations for reference only.
Your model may differ from
the units shown.

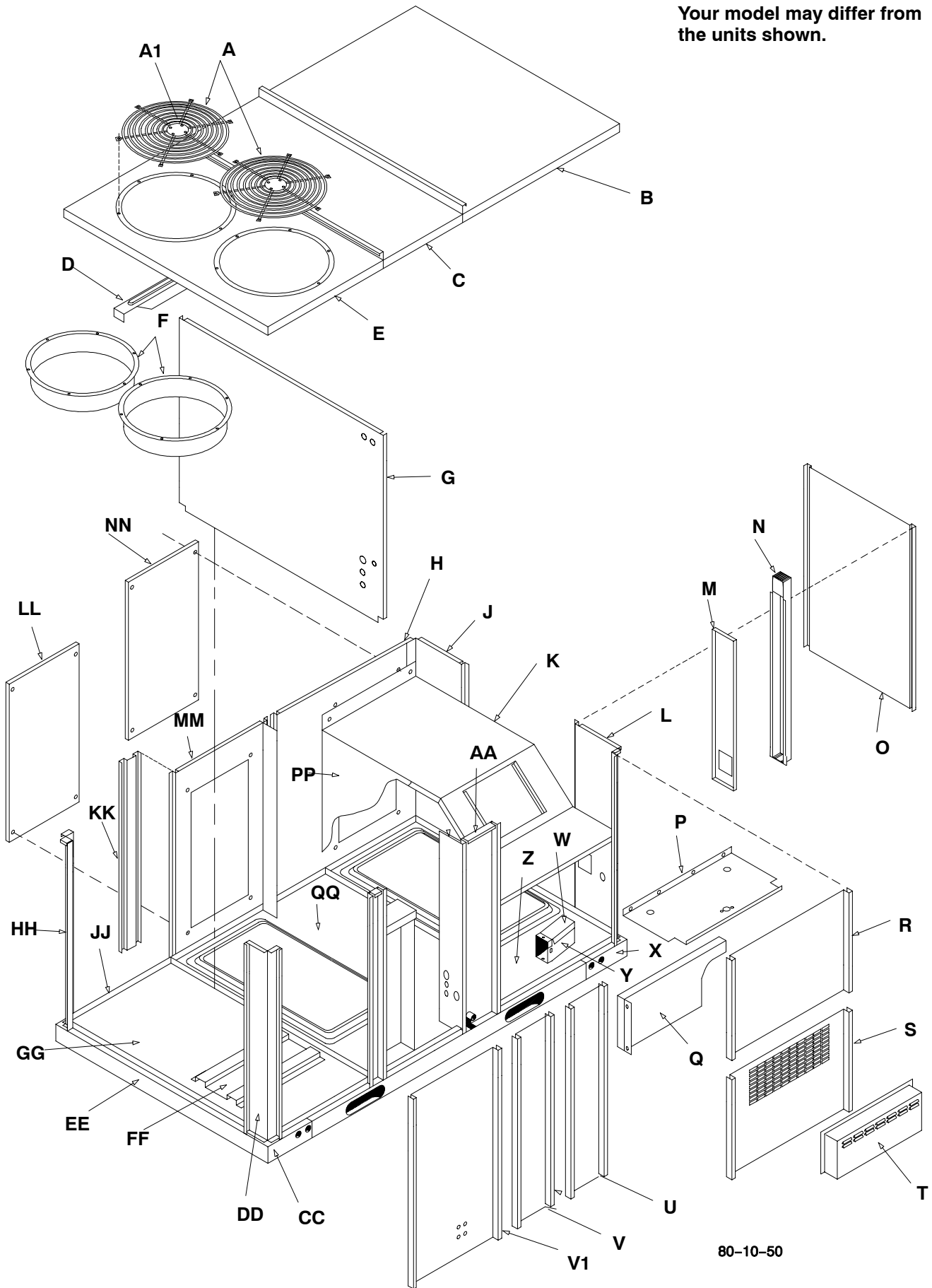

80-10-50

Illustrations for reference only.
Your model may differ from
the units shown.

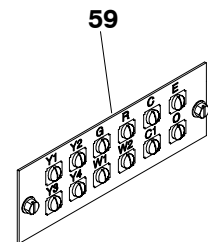
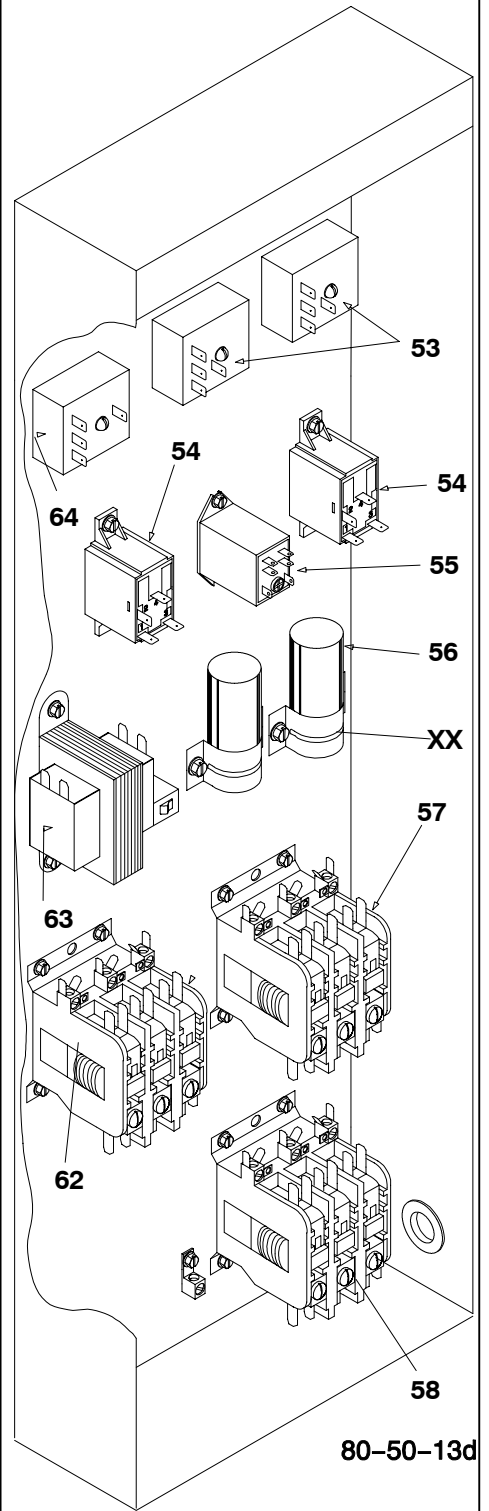
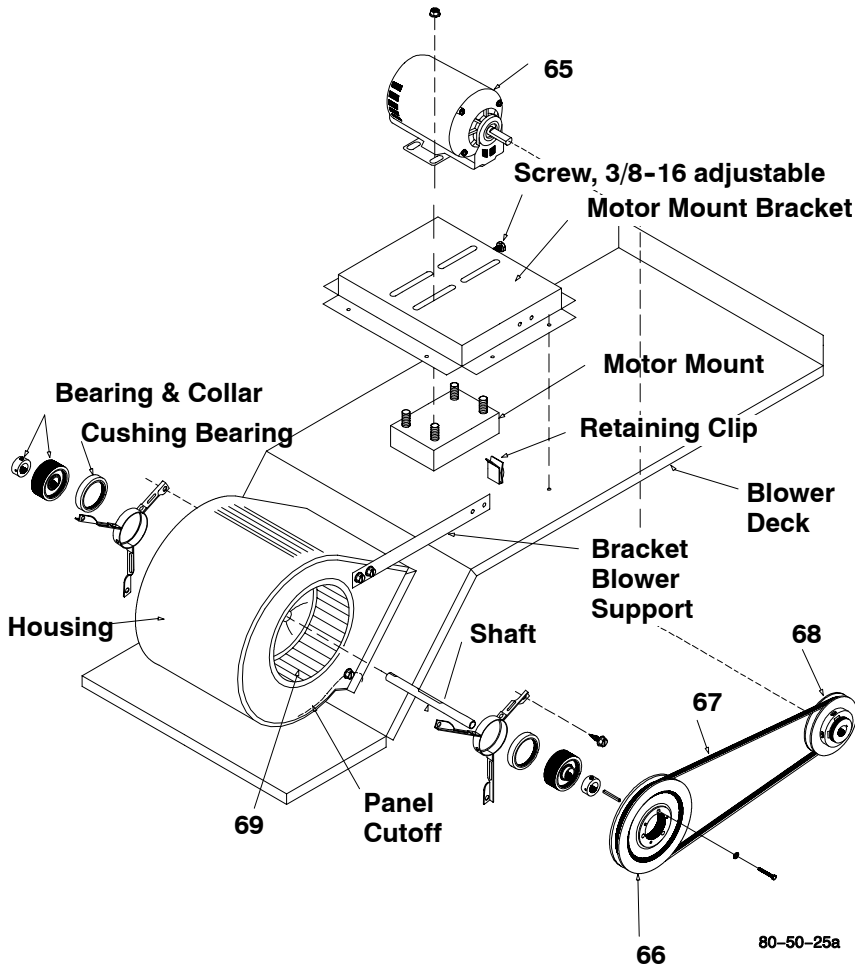

CFM	EXTERNAL STATIC PRESSURE IN INCHES WATER COLUMN (PASCALS)															
	.25 (62)		.50 (124)		.75 (186)		1.0 (249)		1.25 (311)		1.50 (373)		1.75 (435)		2.0 (497)	
	RPM	W	RPM	W	RPM	W	RPM	W	RPM	W	RPM	W	RPM	W	RPM	W
2500					1000	1250	1100	1500	1175	1700	1260	2000	1340	2250		
2750			960	1250	1050	1400	1140	1750	1224	2000	1290	2250	1360	2500		
3000	945	1250	1010	1500	1100	1750	1190	2000	1250	2250	1325	2600				
3250	1000	1550	1075	1800	1160	2100	1240	2400	1300	2600	1391	3050				
3500	1050	1800	1125	2150	1200	2250	1290	2600	1350	2800						

PULLEY TURNS OPEN		0	1	2	3	4	5
FAN	2 HPSTD PULLEY	1224	1139	1113	1057	1001	945
RPM	2 HP HIGH STATIC PULLEY	1391	1335	1280	1224	1169	1113

CFM	EXTERNAL STATIC PRESSURE IN INCHES WATER COLUMN (PASCALS)															
	.25 (62)		.50 (124)		.75 (186)		1.0 (249)		1.25 (311)		1.50 (373)		1.75 (435)		2.0 (497)	
	RPM	W	RPM	W	RPM	W	RPM	W	RPM	W	RPM	W	RPM	W	RPM	W
2500					1000	1250	1100	1500	1175	1700	1260	2000	1340	2250		
2750			960	1250	1050	1400	1140	1750	1224	2000	1290	2250	1360	2500		
3000	945	1250	1010	1500	1100	1750	1190	2000	1250	2250	1325	2600				
3250	1000	1550	1075	1800	1160	2100	1240	2400	1300	2600	1391	3050				
3500	1050	1800	1125	2150	1200	2250	1290	2600	1350	2800						

PULLEY TURNS OPEN		0	1	2	3	4	5
FAN	STD PULLEY	1224	1139	1113	1057	1001	945
RPM	HIGH STATIC PULLEY	1391	1335	1280	1224	1169	1113

CFM	EXTERNAL STATIC PRESSURE IN INCHES WATER COLUMN (PASCALS)															
	.25 (62)		.50 (124)		.75 (186)		1.0 (249)		1.25 (311)		1.50 (373)		1.75 (435)		2.0 (497)	
	RPM	W	RPM	W	RPM	W	RPM	W	RPM	W	RPM	W	RPM	W	RPM	W
2500					1000	1250	1100	1500	1175	1700	1260	2000	1340	2250		
2750			960	1250	1050	1400	1140	1750	1224	2000	1290	2250	1360	2500		
3000	945	1250	1010	1500	1100	1750	1190	2000	1250	2250	1325	2600				
3250	1000	1550	1075	1800	1160	2100	1240	2400	1300	2600	1391	3050				
3500	1050	1800	1125	2150	1200	2250	1290	2600	1350	2800						

PULLEY TURNS OPEN		0	1	2	3	4	5
FAN	STD PULLEY	1224	1139	1113	1057	1001	945
RPM	HIGH STATIC PULLEY	1391	1335	1280	1224	1169	1113

CFM	EXTERNAL STATIC PRESSURE IN INCHES WATER COLUMN (PASCALS)															
	.25 (62)		.50 (124)		.75 (186)		1.0 (249)		1.25 (311)		1.50 (373)		1.75 (435)		2.0 (497)	
	RPM	W	RPM	W	RPM	W	RPM	W	RPM	W	RPM	W	RPM	W	RPM	W
6750					890	2050	950	2500	1000	2700	1050	3000	1090	3100	1140	3450
7000					925	2500	975	2750	1025	2975	1075	3250	1125	3000	1160	3800
7250			900	2500	950	2750	1000	3025	1050	3350	1100	3625	1150	4000	1190	4200
7500	875	2500	925	2875	975	3075	1025	3450	1075	3625	1125	4000	1175	4375	1220	4750
7750	900	2875	960	3150	1010	3525	1060	3825	1110	4250	1150	4375	1200	4750	1236	5000
8000	950	3250	1000	3625	1050	3900	1100	4375	1140	4600	1180	4825	1230	5125		
8250	990	3625	1025	4000	1075	4375	1125	4750	1170	5075	1210	5325				

PULLEY TURNS OPEN		0	1	2	3	4	5
FAN	STD PULLEY	1150	1097	1045	993	940	888
RPM	HIGH STATIC PULLEY	1236	1172	1107	1042	977	911

CFM	EXTERNAL STATIC PRESSURE IN INCHES WATER COLUMN (PASCALS)															
	.25 (62)		.50 (124)		.75 (186)		1.0 (249)		1.25 (311)		1.50 (373)		1.75 (435)		2.0 (497)	
	RPM	W	RPM	W	RPM	W	RPM	W	RPM	W	RPM	W	RPM	W	RPM	W
5250	875	2500	925	2875	975	3075	1025	3450	1075	3625	1125	4000	1175	4375	1220	4750
5500	900	2875	960	3150	1010	3525	1060	3825	1110	4250	1150	4375	1200	4750	1236	5000
5750	950	3250	1000	3625	1050	3900	1100	4375	1140	4600	1180	4825	1230	5125		
6000	990	3625	1025	4000	1075	4375	1125	4750	1160	4900	1215	5500				
6250	1025	4200	1060	4475	1110	4850	1160	5200	1200	5600						
6500	1060	4700	1100	5025	1150	5450	1190	5800	1236	6000						
6750	1100	5125	1140	5500	1180	5875										

PULLEY TURNS OPEN		0	1	2	3	4	5
FAN	STD PULLEY	1150	1097	1045	993	940*	888
RPM	HIGH STATIC PULLEY	1236	1172	1107	1042	977	911

CFM	EXTERNAL STATIC PRESSURE IN INCHES WATER COLUMN (PASCALS)															
	.25 (62)		.50 (124)		.75 (186)		1.0 (249)		1.25 (311)		1.50 (373)		1.75 (435)		2.0 (497)	
	RPM	W	RPM	W	RPM	W	RPM	W	RPM	W	RPM	W	RPM	W	RPM	W
5250	875	2500	925	2875	975	3075	1025	3450	1075	3625	1125	4000	1175	4375	1220	4750
5500	900	2875	960	3150	1010	3525	1060	3825	1110	4250	1150	4375	1200	4750	1236	5000
5750	950	3250	1000	3625	1050	3900	1100	4375	1140	4600	1180	4825	1230	5125		
6000	990	3625	1025	4000	1075	4375	1125	4750	1160	4900	1215	5500				
6250	1025	4200	1060	4475	1110	4850	1160	5200	1200	5600						
6500	1060	4700	1100	5025	1150	5450	1190	5800	1236	6000						
6750	1100	5125	1140	5500	1180	5875										

PULLEY TURNS OPEN		0	1	2	3	4	5
FAN	STD PULLEY	1150	1097	1045	993	940*	888
RPM	HIGH STATIC PULLEY	1236	1172	1107	1042	977	911

Wiring Diagrams - ALL Except 575V

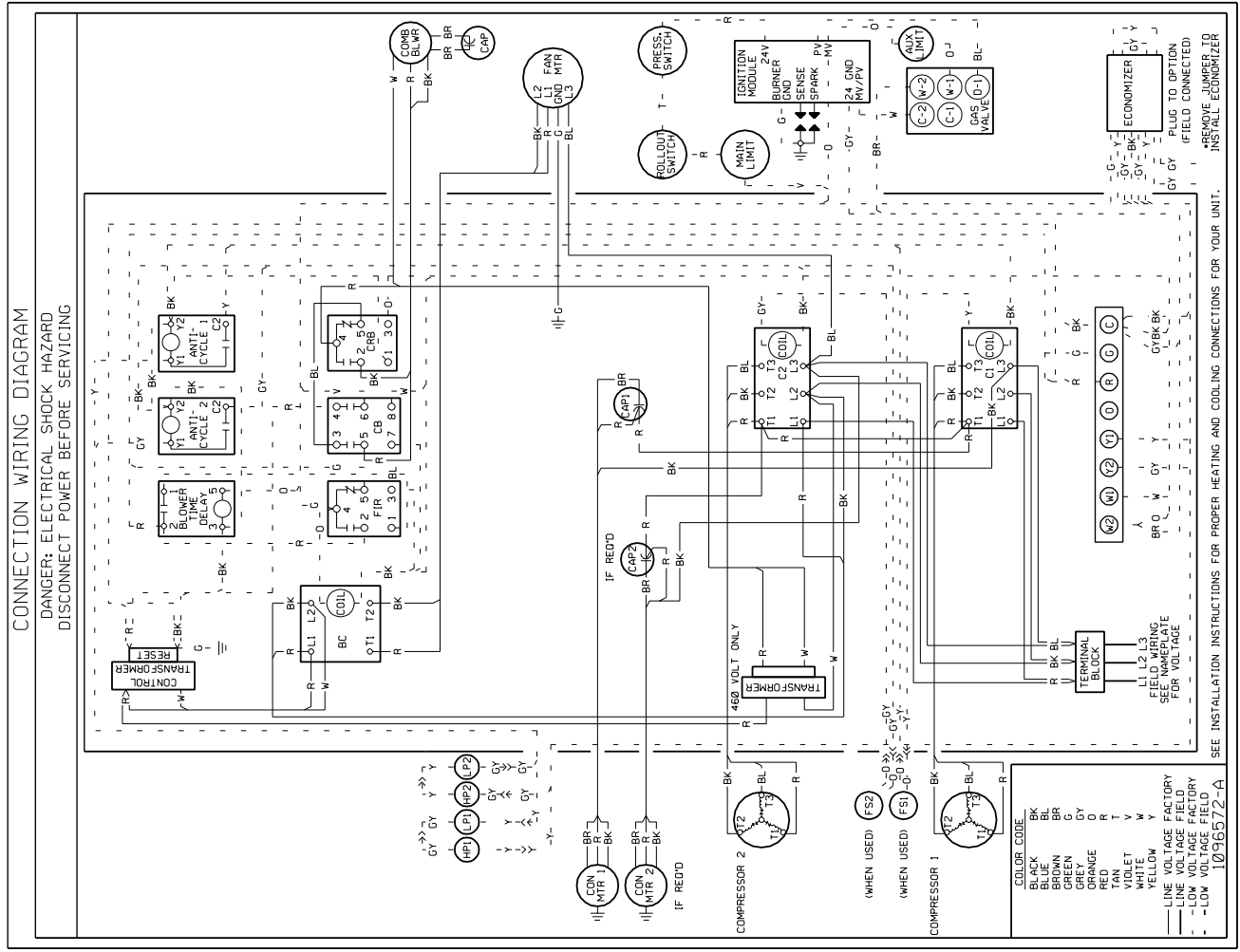
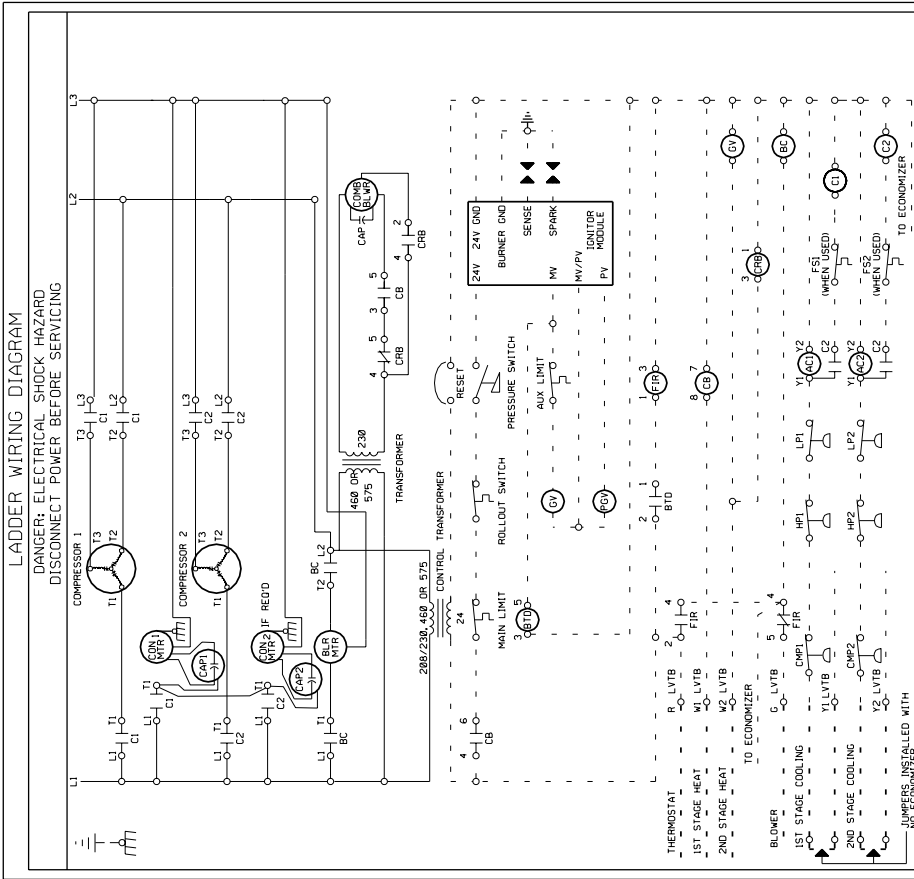

Wiring Diagrams - 575V Models

