

# CHS SERIES

## 15 TON

# TEMPSTAR®

Heating and Cooling Products

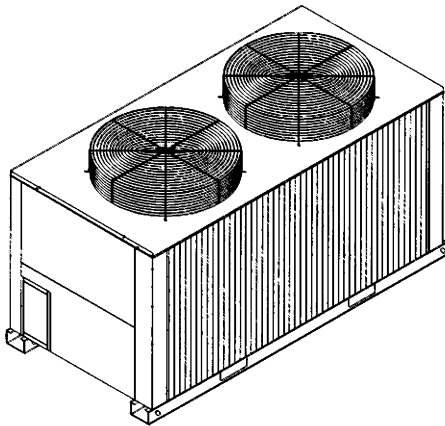

Representative photo only, some models may vary in appearance.

### COMMERCIAL SPLIT SYSTEM HEAT PUMPS

#### Standard-Efficiency Outdoor Section

##### REFRIGERATION CIRCUIT

- All models are equipped with reciprocating serviceable, semi-hermetic compressor with spring isolators, automatically reversible oil pump, and thermal overload protection.
- Copper tube/aluminum fin condensor coils with mechanically bonded plate fins and sub cooling circuit.
- Suction line accumulator with fusible plug.
- High pressure switch, loss of charge switch, and crankcase heaters.
- State of the art defrost system.
- Direct drive, vertical discharge fans.
- Compressor short cycle protection.
- Liquid line solenoid valve
- Intermediate season head pressure control.

##### BUILT TO LAST

- Pre-painted galvanized steel cabinet for long life and quality appearance.
- Commercial strength base rails with built-in rigging capability.

##### EASY TO INSTALL AND SERVICE

- Ground or rooftop installation
- Liquid and suction line service valves.
- Low voltage control wire terminal block.
- One (1) year limited warranty on parts and a five (5) year compressor protection plan.



RESIDENTIAL AND COMMERCIAL SYSTEMS • SPLIT SYSTEMS • PACKAGED AIR CONDITIONERS •  
COMBINATION GAS / ELECTRIC UNITS • HEAT PUMPS • AIR HANDLERS • MANUFACTURED HOME AIR  
CONDITIONERS • GAS, OIL AND ELECTRIC FURNACES

506 21 2102 01

International Comfort Products  
650 Heil Quaker Avenue  
Lewisburg, Tn. 37091

9/27/05

# Table of Contents

	Page
Features/Benefits .....	1
Model Number Nomenclature .....	2
Unit Specifications .....	3-4
Dimensions .....	5
Performance Data .....	6-7
Typical Installation .....	8
Accessories .....	9
Operating Sequence .....	9
Guide Specs .....	9

## MODEL NUMBER IDENTIFICATION GUIDE

<b>MODEL NUMBER</b>	<b>C</b>	<b>H</b>	<b>S</b>	<b>180</b>	<b>H</b>	<b>000</b>	<b>B</b>	
<b>PRODUCT FAMILY</b> Condenser								<b>Sales Code</b>
<b>TYPE</b> H= Heat Pump A = Air Conditioner							<b>000 = NO HEAT</b>	
							<b>VOLTAGE / PHASE / HERTZ</b> H = 208/230-3-60 L = 460-3-60	
<b>DESIGN SERIES</b> S = Standard Efficiency E = Ashrae Efficient							<b>COOLING CAPACITY (NOMINAL BTUH)</b> 180 = 15 Ton	

	UNIT SPECIFICATIONS	
Electrical	CHS180H000B	CHS180L000B
Volts / Phase / Hertz	208-230/3/60	460/3/60
Voltage Min - Max	187-253	414-528
Total Unit Amps	67.9	31.6
Min. Circuit Amp.	87.5	40.7
Power Supply MOCP *	125	60
Compressor - 1 Circuit	Semi-hermetic Reciprocating	
Circuit 1 - RLA / LRA	63.6 / 266	29.3 / 120
Type	One 06DF537 **	One 06DF537 **
No. Cylinders	6	6
Speed (rpm)	1750	1750
Oil (Oz)	128	128
Condenser Fan Data		
Quantity	2	2
Volts/Phase/Hertz	208-230/1/60	460/1/60
FLA	4.3	2.3
Watts Total	1460	1460
Blades/Diameter	2 / 26	2 / 26
Hp - Rpm - Speeds	1/2 / 1075 / 1	1/2 / 1075 / 1
Bearing Type	Sleeve	Sleeve
Rotation (Shaft End)	CCW	CCW
Max. CFM	11,000	11,000
Condenser Coil		
Rows / Fins per Inch	3 / 15	3 / 15
Total Face Area-Sq. ft.	29.2	29.2
Tube Diameter	3/8"	3/8"
Refrigerant		
Type	R-22	R-22
Shipping Charge - (lbs.)	3 ***	3 ***
Approximate Operating Charge - (lbs.), Based On BHC/HBC180 Series Air Handler	37 ****	37 ****
Line Size Liquid I.D. (in.)	5/8"	5/8"
Line Size Suction I.D. (in.)	1-5/8"	1-5/8"
Controls		
High Press. Switch Auto Reset - Open / Close psi	395 (+/-20) / 295 (+/-20)	395 (+/-20) / 295 (+/-20)
Low Press. Switch Auto Reset - Open- Close psi	7 (+/-3) / 22 (+/-5)	7 (+/-3) / 22 (+/-5)
Defrost Sensor - Open- Close psi	28° F	28° F
Crankcase Heater Type	Band	Band
Misc.		
Operating Weight ( lbs. )	803	803

\* Fuse or HACR circuit breaker

\*\* Equipped with electrically operated unloader, capacity steps 100%, 67% in cooling mode.

\*\*\* Unit is factory supplied with holding charge only.

\*\*\*\* Typical operating charge with 25 ft. of interconnecting pipe.

PERFORMANCE DATA COOLING				
Standard Outdoor Unit / Indoor Unit	Rated Net Capacity Btuh*	IPLV	EER	Evaporator Rated Airflow
CHS180 / BHC/HBC180	174,000	11.3	9.0	6000
PERFORMANCE DATA HEATING				
Standard Outdoor Unit / Indoor Unit	High Heat Capacity Btuh*	Low Heat Capacity Btuh*	High Heat COP	Low Heat COP
CHS180 / BHC/HBC180	172,000	100,000	3.1	2.1

\* Net Capacity Ratings based on ARI Test Standards, 95° F Amb. 80° F DB / 67° F WB.

Outdoor Sound Power									
Unit	Sound Rating dBA (60 Hz)	Octave Bands							
		63	125	250	500	1000	2000	4000	8000
CHS180	86.0	N/A	93.0	86.0	83.0	80.0	78.0	73.0	71.0

Bels = Sound Levels (1 bel = 10 decibels)

## LEGENDS AND NOTES

### Legend

Bhp	=	Brake Horsepower
Bels	-	Sound Levels
EER	-	Energy Efficiency Ratio
IPLV	-	Integrated Part Load Values
MCA	-	Minimum Circuit Amps
MOCPP	-	Maximum Over-current Protection
FLA	-	Full Load Amps
LRA	-	Locked Rotor Amps
*	-	Fuse or HACR circuit breaker
RLA	-	Rated Load Amps

- NOTES: 1. Rated in accordance with ARI Standards 360-89 and 270-89.  
 2. The CHS is beyond the scope of the ARI Certification Program.  
 3. ARI ratings are net values, reflecting the effects of circulating fan heat.  
 4. Ratings are based on:  
 Cooling Standard: 80F db, 67F wb indoor entering air temperature and 95F db air entering outdoor unit.  
 IPLV Standard: 80F db, 67F wb indoor entering air temperature and 80F db entering air temperature.

EXAMPLE: Supply voltage is 460-3-60.

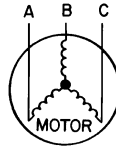

AB = 452 v  
 BC = 464 v  
 AC = 455 v

$$\begin{aligned} \text{Average Voltage} &= \frac{452 + 464 + 455}{3} \\ &= \frac{1371}{3} \\ &= 457 \end{aligned}$$

Determine maximum deviation from average voltage.

(AB) 457 - 452 = 5 V  
 (BC) 464 - 457 = 7 V  
 (AC) 457 - 455 = 2 V

Maximum deviation is 7 v.

Determine percent voltage imbalance.

$$\begin{aligned} \% \text{ Voltage Imbalance} &= 100 \times \frac{7}{457} \\ &= 1.53\% \end{aligned}$$

This amount of phase imbalance is satisfactory as it is below the maximum allowable 2%.

**IMPORTANT:** If the supply voltage phase imbalance is more than 2%, contact your local electric utility company immediately.

### NOTES:

- In compliance with NEC requirements for multimotor and combination load equipment (refer to NEC Articles 430 and 440), the over-current protective device for the unit shall be fuse or HACR breaker. Canadian units may be fuse or circuit breaker.

### 2. Unbalanced 3-Phase Supply Voltage

Never operate a motor where a phase imbalance in supply voltage is greater than 2%. Use the following formula to determine the percent voltage imbalance.

$$\begin{aligned} \% \text{ Voltage Imbalance} \\ &= 100 \times \frac{\text{max voltage deviation from average voltage}}{\text{average voltage}} \end{aligned}$$

# CHS180 UNIT DIMENSIONS and CLEARANCES

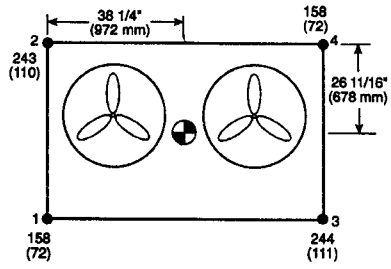
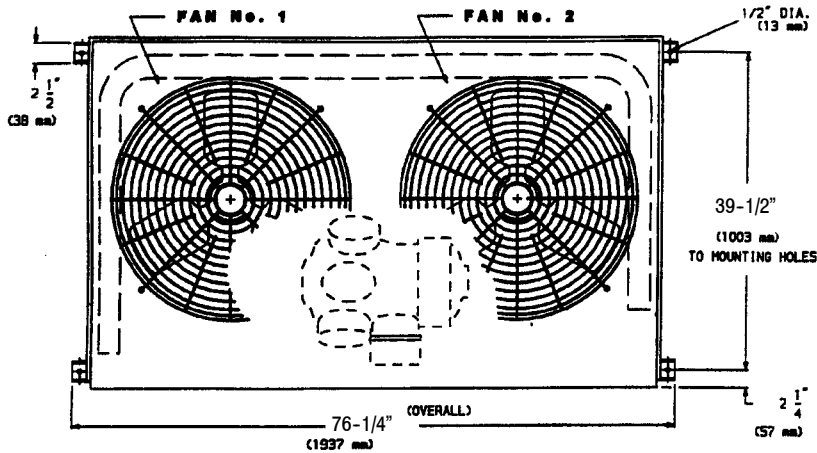

WEIGHT DISTRIBUTION

Unit	Total Weight (365)	Support Point			
		1 (72)	2 (110)	3 (111)	4 (72)
CHS180	803	158	243	244	158

TOP VIEW

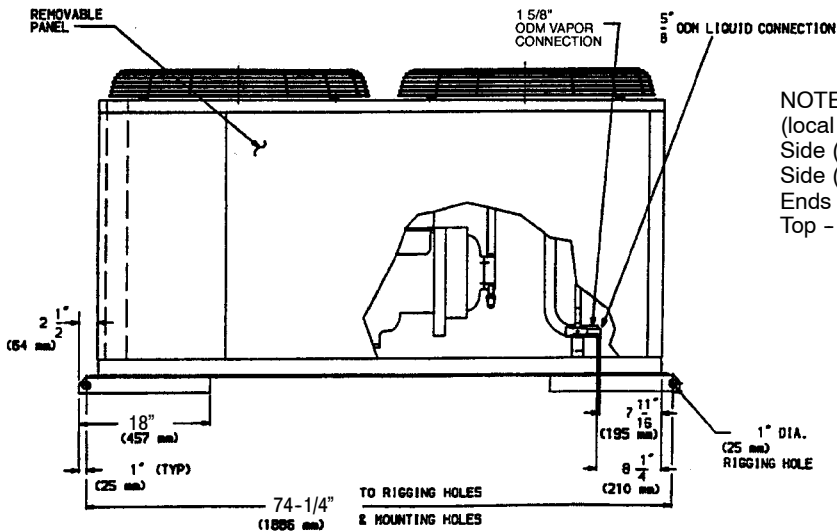

NOTE: Recommended service clearances are as follows (local codes or jurisdictions may prevail):  
 Side (compressor) - 3-1/2 ft. (1067 mm)  
 Side (opposite compressor) - 3 ft. (914 mm)  
 Ends - 2 ft. (616 mm)  
 Top - 5 ft. (1524 mm)

SIDE VIEW

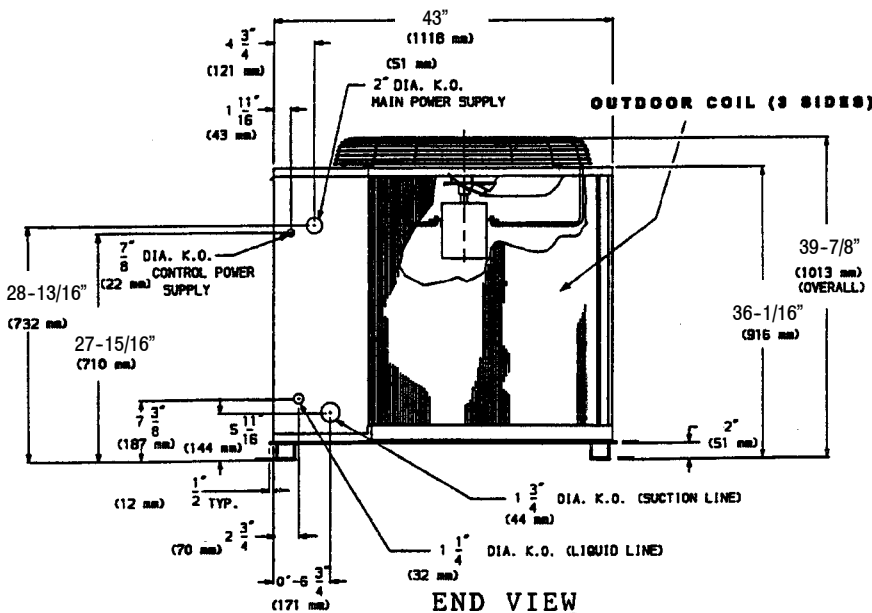

END VIEW

**EXPANDED PERFORMANCE DATA (COOLING) CHS180 / BHC/HBC180 (GROSS CAPACITY)**

Temp (F) Air Ent Outdoor Coil (Edb)		Indoor Entering Air - Cfm/BF								
		4500/0.03			6000/0.05			7500/0.08		
		Indoor Entering Air - Ewb (F)								
		62	67	72	62	67	72	62	67	72
80	TC	172.0	186.0	201.0	181.0	194.0	209.0	190.0	199.0	214.0
	SHC	152.0	127.0	101.0	175.0	146.0	113.0	190.0	163.0	123.0
	kW	13.7	14.2	14.7	14.1	14.5	15.0	14.3	14.7	15.1
85	TC	168.0	182.0	197.0	178.0	190.0	205.0	186.0	195.0	209.0
	SHC	150.0	125.0	100.0	173.0	144.0	111.0	186.0	161.0	122.0
	kW	14.3	14.9	15.4	14.7	15.1	15.7	15.0	15.3	15.8
95	TC	161.0	174.0	189.0	171.0	182.0	196.0	179.0	186.0	200.0
	SHC	146.0	122.0	96.9	169.0	141.0	108.0	179.0	158.0	119.0
	kW	15.5	16.1	16.8	16.0	16.5	17.1	16.4	16.7	17.2
100	TC	158.0	170.0	184.0	167.0	177.0	191.0	176.0	182.0	185.0
	SHC	145.0	121.0	95.3	166.0	139.0	107.0	176.0	156.0	117.0
	kW	16.1	16.8	17.4	16.6	17.1	17.7	17.0	17.3	17.9
105	TC	154.0	166.0	180.0	163.0	173.0	187.0	172.0	178.0	191.0
	SHC	143.0	119.0	93.8	163.0	137.0	105.0	172.0	154.0	116.0
	kW	16.7	17.4	18.1	17.2	17.7	18.4	17.7	18.0	18.6
115	TC	147.0	158.0	172.0	156.0	165.0	177.0	165.0	169.0	181.0
	SHC	139.0	116.0	90.7	156.0	134.0	102.0	165.0	151.0	113.0
	kW	17.9	18.6	19.4	18.5	19.0	19.8	19.0	19.2	20.0
125	TC	139.0	150.0	163.0	149.0	156.0	168.0	157.0	160.0	171.0
	SHC	135.0	112.0	87.5	149.0	131.0	98.8	157.0	147.0	109.0
	kW	19.1	19.8	20.7	19.8	20.2	21.1	20.3	20.5	21.3

**LEGEND**

- BF — Bypass Factor
- Edb — Entering Dry Bulb
- Ewb — Entering Wet Bulb
- kW — Compressor Motor Power Input, Total
- Ldb — Leaving Dry Bulb
- Lwb — Leaving Wet Bulb
- SHC — Sensible Heat Capacity, Gross (1000 Btuh)
- TC — Total Capacity, Gross (1000 Btuh)

**NOTES:**

1. Direct interpolation is permissible. Do not extrapolate.
2. SHC is based on 80 F db air entering indoor coil.  
Below 80 F db, subtract (Corr Factor x Cfm) from SHC.  
Above 80 F db, add (Corr Factor x Cfm) to SHC.

3. Formulas:

$$t_{ldb} = t_{edb} - \frac{\text{sensible heat capacity (Btuh)}}{1.1 \times \text{cfm}}$$

$$t_{lwb} = \text{wet-bulb temperature corresponding to enthalpy of air leaving indoor coil (} h_{lwb} \text{)}$$

$$h_{lwb} = h_{ewb} - \frac{\text{total capacity (Btuh)}}{4.5 \times \text{cfm}}$$

where  $h_{ewb}$  = enthalpy of air entering indoor coil

4. Capacities are based on 25 actual ft (40 equivalent ft) of interconnecting piping sized to the outdoor unit field connections. (Equivalent length is equal to the actual length plus a 50% allowance for fitting losses.) For other equivalent lengths, refer to the Carrier System Design Manual, Part 3, for line losses.

BYPASS FACTOR	ENTERING-AIR DRY-BULB TEMP (F)					
	79	78	77	76	75	under 75
	81	82	83	84	85	over 85
	<b>Correction Factor</b>					
0.03	1.07	2.13	3.20	4.27	5.34	Use formula given.
0.06	1.03	2.07	3.10	4.14	5.17	
0.09	1.00	2.00	3.00	4.00	5.01	
0.12	0.97	1.94	2.90	3.87	4.84	
0.15	0.94	1.87	2.81	3.74	4.68	

Interpolation is permissible.  
Correction Factor = 1.10 x (1 - BF) x (db - 80)

**NET CAPACITIES HEATING - CHS180 WITH BHC/HBC180**

Temp (F) Air Ent Indoor Coil	Indoor Airflow (Cfm)	TEMP AIR ENTERING OUTDOOR COIL (F)										
		- 10	0	10	17	20	30	40	47	50	60	
60	4500	TH	64.4	80.9	99.0	112.0	118.0	137.0	161.0	177.0	184.0	207.0
		THI	59.2	74.5	90.5	102.0	106.0	120.0	154.0	177.0	184.0	207.0
		kW	7.18	7.99	8.87	9.49	9.78	10.80	12.00	12.80	13.20	14.40
	6000	TH	67.3	84.1	103.0	115.0	121.0	142.0	166.0	182.0	190.0	214.0
		THI	61.9	77.4	93.8	105.0	110.0	124.0	158.0	182.0	190.0	214.0
		kW	7.09	7.85	8.65	9.22	9.48	10.40	11.40	12.20	12.50	13.60
	7500	TH	69.7	86.7	105.0	118.0	124.0	144.0	169.0	186.0	193.0	218.0
		THI	64.1	79.7	96.2	108.0	112.0	127.0	162.0	186.0	193.0	218.0
		kW	7.03	7.76	8.51	9.04	9.29	10.10	11.10	11.80	12.10	13.10
65	4500	TH	61.5	78.2	96.4	109.0	115.0	135.0	158.0	174.0	181.0	205.0
		THI	56.6	72.0	88.1	99.5	104.0	118.0	151.0	174.0	181.0	205.0
		kW	7.37	8.22	9.14	9.79	10.10	11.10	12.30	13.20	13.60	14.80
	6000	TH	64.4	81.5	100.0	113.0	119.0	139.0	163.0	180.0	187.0	211.0
		THI	59.3	75.0	91.5	103.0	107.0	122.0	156.0	180.0	187.0	211.0
		kW	7.29	8.08	8.93	9.53	9.80	10.70	11.80	12.60	12.90	14.10
	7500	TH	66.8	84.1	103.0	116.0	122.0	142.0	167.0	184.0	191.0	215.0
		THI	61.5	77.4	94.0	106.0	110.0	125.0	159.0	184.0	191.0	215.0
		kW	7.23	8.00	8.80	9.36	9.61	10.50	11.50	12.20	12.50	13.60
70	4500	TH	58.2	75.3	93.6	106.0	112.0	132.0	155.0	172.0	179.0	202.0
		THI	53.6	69.3	85.6	97.0	101.0	116.0	149.0	172.0	179.0	202.0
		kW	7.56	8.45	9.41	10.10	10.40	11.50	12.70	13.60	14.00	15.30
	6000	TH	61.2	78.6	97.3	110.0	116.0	137.0	161.0	177.0	184.0	208.0
		THI	56.3	72.3	89.0	101.0	105.0	120.0	154.0	177.0	184.0	208.0
		kW	7.48	8.32	9.21	9.83	10.10	11.10	12.20	13.00	13.40	14.50
	7500	TH	63.7	81.2	100.0	113.0	119.0	140.0	164.0	181.0	188.0	212.0
		THI	58.6	74.7	91.5	103.0	108.0	123.0	157.0	181.0	188.0	212.0
		kW	7.43	8.23	9.08	9.67	9.94	10.80	11.90	12.70	13.00	14.10
75	4500	TH	54.7	72.1	90.5	103.0	109.0	129.0	153.0	169.0	176.0	199.0
		THI	50.3	66.3	82.8	94.3	98.7	113.0	146.0	169.0	176.0	199.0
		kW	7.75	8.68	9.68	10.40	10.70	11.80	13.10	14.10	14.50	15.80
	6000	TH	57.7	75.4	94.3	108.0	114.0	134.0	158.0	175.0	182.0	206.0
		THI	53.1	69.4	86.3	98.1	102.0	117.0	151.0	175.0	182.0	206.0
		kW	7.68	8.55	9.48	10.10	10.40	11.40	12.60	13.50	13.80	15.0
	7500	TH	60.1	78.1	97.2	111.0	117.0	137.0	161.0	178.0	186.0	210.0
		THI	55.3	71.8	88.9	101.0	105.0	120.0	154.0	178.0	186.0	210.0
		kW	7.63	8.47	9.36	9.98	10.30	11.20	12.30	13.10	13.40	14.50

**LEGEND**

- kW - Compressor motor Power Input (Total)
- TH - Total Heating Capacity (1000 Btuh)
- THI - Integrated Heating Capacity (1000 Btuh)

# Typical Piping and Wiring

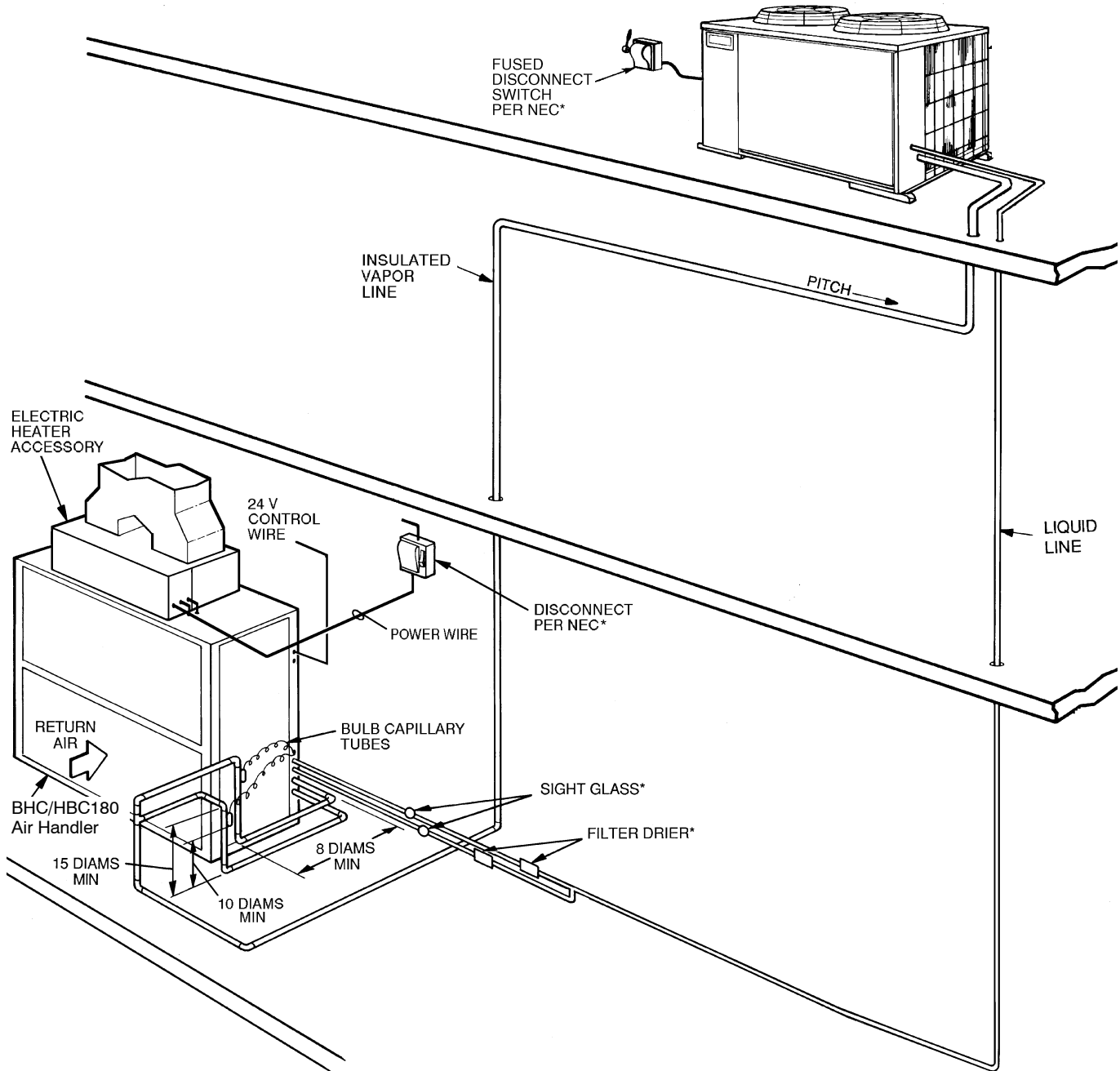

## LEGEND

**NEC** - National Electric Code

**TXV** - Thermostatic Expansion Valve

## NOTES:

1. All piping must follow standard refrigerant piping techniques.
2. All wiring must comply with applicable local and national codes.
3. Wiring and piping shown are general points-of-connection guides only and are not intended for, or to include all details for a specific installation.
4. Filter driers must be bi-flow type suited for heat pump duty.
5. Internal factory-supplied TXV's and check valves not shown.



ACCESSORIES		
Description	Model Number	Used On
Low Ambient Control	AXB175LAA	208/230 Volt
	AXB275LAA	460 Volt
Hail Guard	AXB075HGA	ALL
Coil Guard	AXB075CGA	ALL

## OPERATING SEQUENCE

**Sequence of operation** - CHS180 outdoor unit with BHC/HBC180 indoor unit. Assume the power is on and the thermostat is set at SYSTEM AUTO, FAN AUTO, and desired temperature.

**Cooling** - If power to unit has been off for an extended period of time, energize crankcase heater at least 24 hours prior to starting compressor.

The indoor fans, outdoor fans, and compressor start within 5 minutes (due to compressor time delay) on command from the controlling thermostat in either the Cooling or the Heating mode of operation. When first stage cooling is required, thermostat (TC1) closes, causing the heat pump to start with an unloaded compressor. When TC2 closes, demanding additional cooling, the compressor loads. In a system with a one-stage thermostat, the unit may be wired so the compressor starts fully loaded. The RVS (reversing valve solenoid) is deenergized during Cooling mode operation.

### Heating -

**First stage** - When the thermostat (TH1) calls for heating, the indoor-fan motor, outdoor-fan motors, and the compressor (fully loaded) are energized. The RVS is energized in the heating mode.

**Second stage** - If additional heating is required, TH2 on the thermostat closes, causing the auxiliary heat supply (i.e., electric resistance heat) to be energized in 1 or 2 stages depending on the number of stages available and whether the outdoor thermostats are closed.

**Defrost Cycle** - Defrost is initiated by a timer which may be set to 30, 50, or 90 minutes. The cycle begins when the defrost timer motor contacts close for 20 seconds. If the defrost thermostat is closed, the reversing valve and outdoor-air fans are deenergized. The unit operates on this modified Cooling mode to defrost the coil. The defrost cycle continues until the defrost thermostat or defrost high pressure switch opens or 10 minutes have elapsed.

When the unit is in the defrost cycle, electric resistance heat is energized to prevent cold air recirculation during this modified Cooling mode.

**Air Circulation** - When the fan switch is at FAN ON, the indoor-air fans operate continuously to provide ventilation. The thermostat operates the other components as described above.

**Emergency Heat Cycle** - If the compressor is inoperative due to a tripped safety device, the second stage of the thermostat automatically energizes the indoor-air fan and the electric resistance heaters.

If desired, the compressor can be manually locked out by setting the thermostat for emergency heat. In this instance, the emergency heat indicator light on the thermostat assembly is illuminated.

## GUIDE SPECIFICATIONS: CHS180

### SYSTEM DESCRIPTION:

Outdoor-mounted, electrically controlled, air-cooled split system heat pump unit utilizing a semi-hermetic compressor for refrigerant compression. Unit shall function as the outdoor component of an air-to-air electric heat pump system. Unit can be used in a refrigerant circuit to match Packaged Air Handling Unit(s), for matched systems approved by manufacturer.

### CABINET:

Cabinet shall be constructed of galvanized steel, bonderized, and finished with baked enamel. Fan venturi housings and guards shall be assembled on the unit.

A removable panel or hinged door shall be provided for access to the compressor and control compartments. A refrigerant accumulator with a fusible plug relief shall be installed in the cabinet.

### COILS:

Coil shall have copper tubes, aluminum plate fins (copper fins optional), and galvanized steel tube sheets. The fins shall be bonded to tubes by mechanical expansion. Coil shall be circuited for subcooling during Cooling mode operation.

### CONDENSER FAN:

Propeller fans shall be directly driven by weather-proof motors. Fan motor bearings shall be permanently lubricated. The lead fan motor shall be suitable for application with accessory head pressure control. Fans shall be arranged for vertical up blast discharge.

### COMPRESSOR

Semi-hermetic, reciprocating-type compressor shall be complete with a motor and oil pump all on a single polished crankshaft. Motor stator winding shall be NEMA Class F rated, suitable for operation in a refrigerant atmosphere.

Oil pump shall be automatically reversible.

Casing shall include suction and discharge shut-off valves, capacity control device, oil level control orifice, oil-pressure regulating valve, and a crankcase oil heater.

Suction and discharge valves shall be Swedish steel, reed-type flapper valves.

Pistons and connecting rods shall be high-density aluminum alloy castings. Pistons shall be equipped with automotive-type compression and oil scraper rings.

Pump-end bearing shall be cast aluminum. Motor-end bearing shall be steel-backed, tin-base babbitt type. Compressor assembly shall be installed on spring vibration isolators.