

INSTALLATION INSTRUCTIONS

Fan Coils

REM4P, REM4X

These instructions must be read and understood completely before attempting installation.

Safety Labeling and Signal Words

DANGER, WARNING, CAUTION, and NOTE

The signal words **DANGER**, **WARNING**, **CAUTION**, and **NOTE** are used to identify levels of hazard seriousness. The signal word **DANGER** is only used on product labels to signify an immediate hazard. The signal words **WARNING**, **CAUTION**, and **NOTE** will be used on product labels and throughout this manual and other manuals that may apply to the product.

DANGER – Immediate hazards which **will** result in severe personal injury or death.

WARNING – Hazards or unsafe practices which **could** result in severe personal injury or death.

CAUTION – Hazards or unsafe practices which **may** result in minor personal injury or product or property damage.

NOTE – Used to highlight suggestions which **will** result in enhanced installation, reliability, or operation.

Signal Words in Manuals

The signal word **WARNING** is used throughout this manual in the following manner:



The signal word **CAUTION** is used throughout this manual in the following manner:



Signal Words on Product Labeling

Signal words are used in combination with colors and/or pictures on product labels.

TABLE OF CONTENTS

INTRODUCTION	2
LOCATION	2
HEATER PACKAGES	2
POSITION UNIT	2
AIR DUCTS	6
ELECTRICAL CONNECTIONS	6
REFRIGERANT TUBING	9
REFRIGERANT FLOW-CONTROL DEVICE	10
REFRIGERANT METERING DEVICE	10
CONDENSATE DRAINS	10
ACCESSORIES	11
SEQUENCE OF OPERATIONS	12
START-UP PROCEDURE	12
CARE AND MAINTENANCE	12
AIRFLOW PERFORMANCE	13
AIR DELIVERY PERFORMANCE	13
ELECTRIC HEATER STATIC PRESSURE DROP	13
R-410A QUICK REFERENCE GUIDE	14

PERSONAL INJURY, AND/OR PROPERTY DAMAGE HAZARD

Failure to carefully read and follow this warning could result in equipment malfunction, property damage, personal injury and/or death.

Installation or repairs made by unqualified persons could result in equipment malfunction, property damage, personal injury and/or death.

The information contained in this manual is intended for use by a qualified service technician familiar with safety procedures and equipped with the proper tools and test instruments.

Installation must conform with local building codes and with the National Electrical Code NFPA 70-2011 current edition.

INTRODUCTION

Models REM4P and REM4X are for R-410A refrigerant. Models REM4P and REM4X are designed for maximum flexibility and can be used for upflow, horizontal left or right,

and downflow applications (accessory kit required for downflow).

REM4P models are available for system sizes 2 through 4 (24,000 – 48,000 BTUH) tons and REM4X models are available for system size 5 tons (60,000 BTUH) nominal cooling capacity. All models use an ECM integral electronically commutated motor for efficiency. The 2 through 4 ton models use a piston metering device, the 5 ton model uses a TXV metering device

All models require a field supplied air filter. Factory approved electric heater packages are available in sizes 5kW through 30kW. See Product Specification literature for available accessory kits

LOCATION

Select the best position which suits the installation site conditions. The location should provide adequate structural support, space in the front of the unit for service access, clearance for return air and supply duct connections, space for refrigerant piping connections and condensate drain line connections. If heaters are being installed make sure adequate clearance is maintained from supply duct work.

See clearances below.

If the unit is located in an area of high humidity, nuisance sweating of casing may occur. On these installations a wrap of 2" (51mm) fiberglass insulation with a vapor barrier is recommended.

NOTE: Internal filter can be accessed from separate filter door. If the filter can **NOT** be easily accessed, a remote filter is recommended. Refer to ACCA Manual D for remote filter sizing.

WARNING

FIRE HAZARD

Failure to maintain proper clearances could result in personal injury, death, and/or property damage.

When heaters are installed, maintain clearances from combustible materials as specified on unit rating plate. Do not use plastic lined or combustible flexible ducting within 36 inches of the supply end of the fan coil.

REQUIRED CLEARANCES – ALL MODELS inches (mm)		
No Heaters	All Sides	0
	From Supply Duct	0
With Heaters	All Sides	0
	From First 3 feet of Supply Duct to Combustibles	1 (25)
	From Supply Duct to Combustibles after 3 feet	0

HEATER PACKAGES

Factory approved, field installed, UL listed heater packages are available from the equipment supplier. See unit rating plate for a list of factory approved heaters. Heaters that are not factory approved could cause damage which would not be covered under the equipment warranty.

POSITION UNIT

Unit can stand or lie on floor, or hang from ceiling or wall. Allow space for wiring, piping, and servicing unit.

CAUTION

PROPERTY DAMAGE HAZARD

Failure to follow this caution may result in property damage

A field fabricated auxiliary drain pan, with a separate drain is **REQUIRED** for all installations over a finished living space or in any area that may be damaged by overflow from a restricted main drain pan. In some localities, local codes require an auxiliary drain pan for **ANY** horizontal installation.

A. UPFLOW INSTALLATION

If return air is to be ducted through a floor, set unit on floor over opening and use 1/8 to 1/4 inch thick (3 to 6 mm thick) fireproof resilient gasket between duct, unit, and floor.

Side return is a field option on slope coil models. Cut opening per dimensions shown in **Figure 1**. A field-supplied bottom closure is required.

C. DOWNFLOW INSTALLATION

CAUTION

PRODUCT OR PROPERTY DAMAGE HAZARD

Failure to follow this caution may result in product or property damage

The conversion of the fan coil to downflow requires special procedures for the condensate drains on both A-coil and Slope-coil units. The vertical drains have an overflow hole between the primary and secondary drain holes. This hole is plugged for all applications except downflow, and must be used for downflow.

Failure to follow instructions could result in personal injury or product and property damage.

WARNING

STRUCTURAL DAMAGE

Failure to follow this warning could result in personal injury or death, or property damage.

Combustible floor base is required when installing in a downflow application with electric heat strips.

Structural damage could occur if manufacturer's downflow base accessory kit is not use when installing in a downflow application.

In this application, field conversion of the evaporator coil is required using accessory Downflow Kit along with an accessory Base Kit. Set unit on floor over opening and use 1/8" to 1/4" thick fireproof resilient gasket between duct, unit, and floor. Refer to installation instructions packaged with accessory kit. See Product Specification literature for kit part numbers.

During the conversion process, removed the plastic cap covering the vertical drains only and discard.

Remove the plug from the overflow hole and discard.

At completion of the downflow installation, caulk around the vertical pan fitting to door joint to retain low air leak performance of the unit.

NOTE: Gasket kit number (EBAC01GSK) is also required for all downflow applications to maintain low air leak/low sweat performance.

Figure 1

Upflow Installation

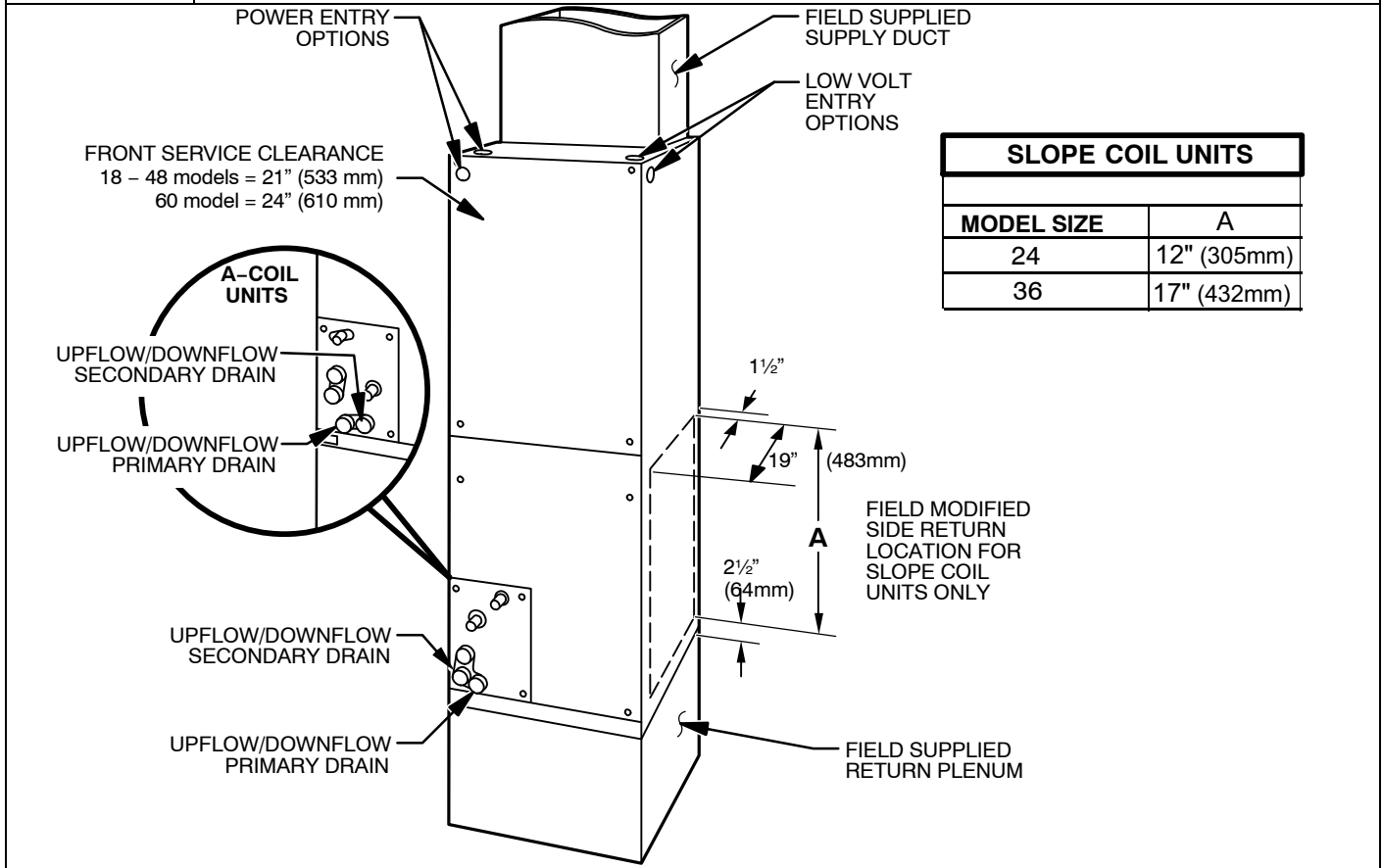
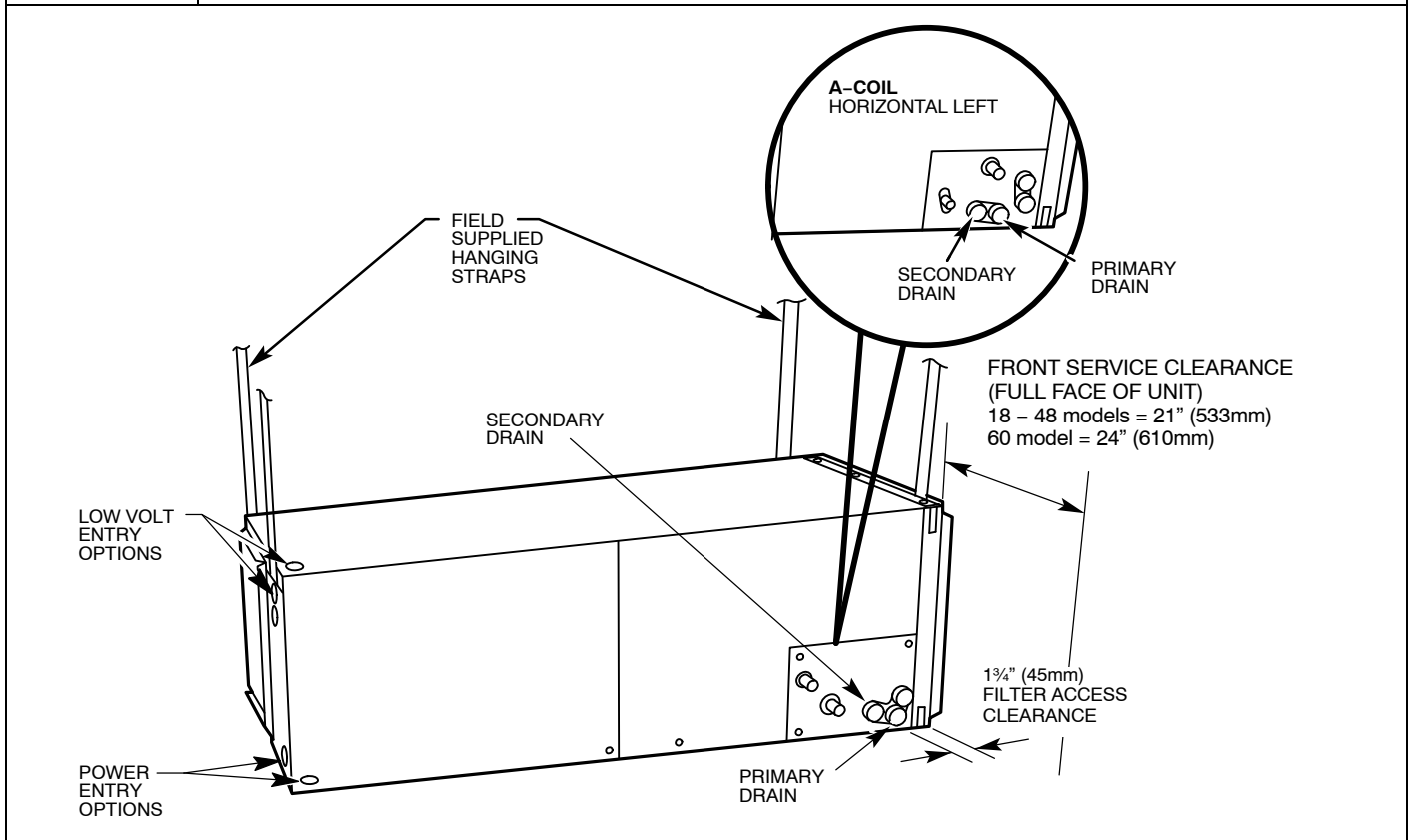

Figure 2

Slope Coil In Horizontal Left Application (factory configuration)



D. HORIZONTAL INSTALLATION

Unit must NOT be installed with access panels facing up or down. Access panels must only face to the side.

REM4P and REM4X models are factory built for horizontal left installation (refer to **Figure 2** and **Figure 3**). They can be field converted to horizontal right (accessory Gasket Kit required, see Product Specification literature for part number). Refer to **Figure 4** and **Figure 5**.

NOTE: When suspending unit from ceiling, dimples in casing indicate suitable location of screws for mounting metal support straps (refer to **Figure 2**).

NOTE: For optimum condensate drainage performance in horizontal installations, unit should be leveled along its length and width.

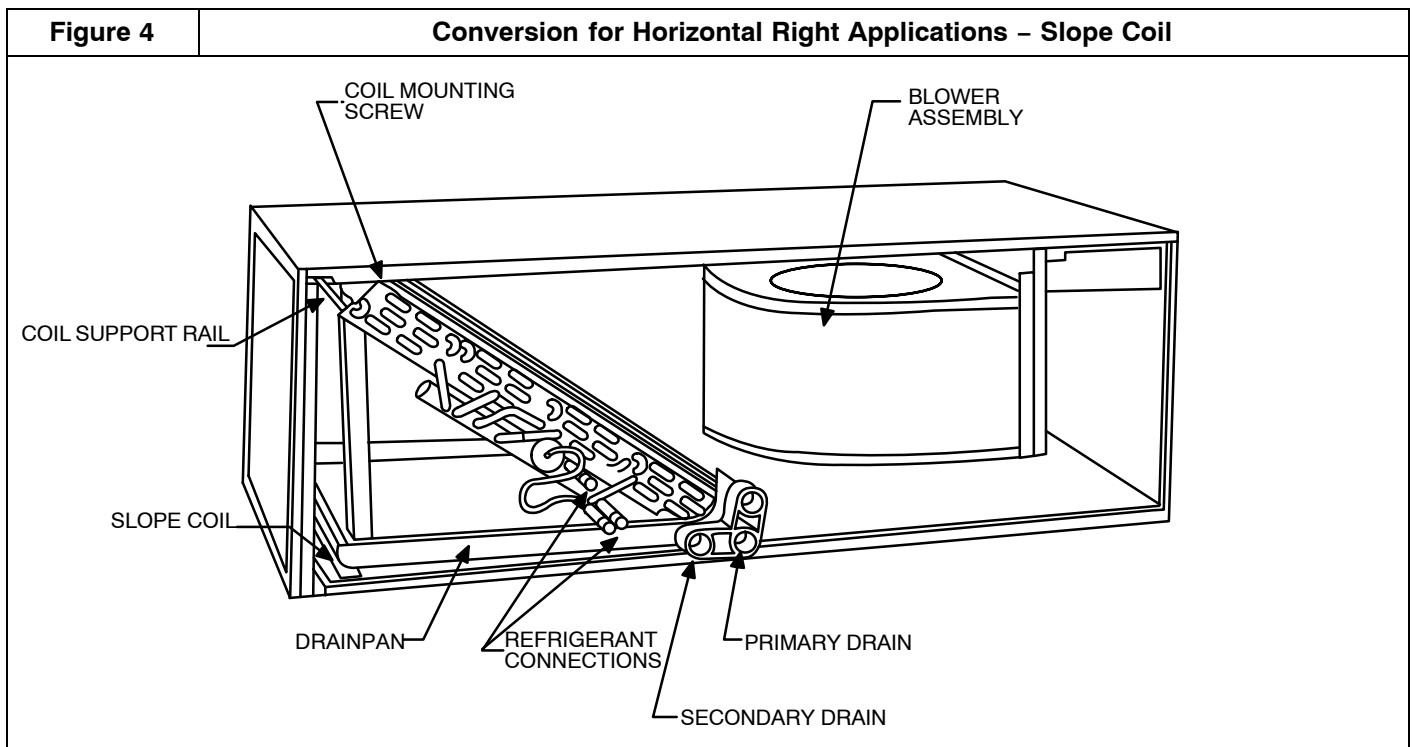
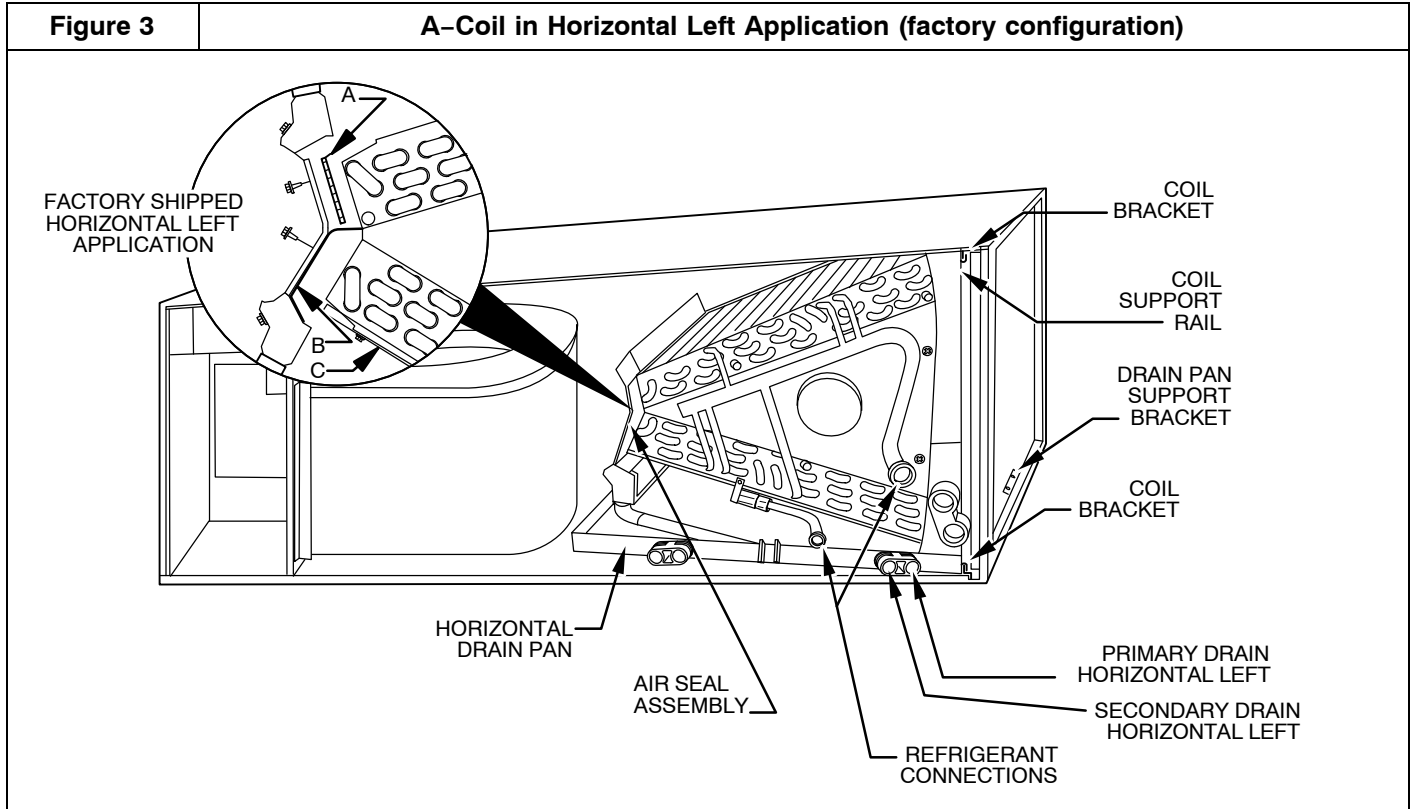

Horizontal Right Conversion of Units With Slope Coils

1. Remove blower and coil access panel and fitting panel (refer to **Figure 4**).
2. Remove coil mounting screw securing coil assembly to right side casing flange.
3. Remove coil assembly.
4. Lay fan coil unit on its right side and reinstall coil assembly with condensate pan down (refer to **Figure 4**).
5. Attach coil to casing flange using coil mounting screw previously removed.
6. Align holes with tubing connections and condensate pan connections, and reinstall access panels and fitting panel. After brazing, make sure liquid and suction tube grommets are in place to prevent air leaks and cabinet sweating.

Horizontal Right Conversion of Units With A-Coils

1. Remove blower and coil access panel and fitting panel (refer to **Figure 5**).
2. Remove coil mounting screw securing coil assembly to right side casing flange.
3. Remove coil assembly.
4. Lay fan coil unit on its right side and reinstall coil assembly with condensate pan down (refer to **Figure 5**).
5. Remove horizontal drain pan support bracket from coil support rail on left side of unit and reinstall on coil support rail on right side of unit.
6. Convert air-seal assembly for horizontal right (refer to **Figure 5**).
 - a. Remove air-seal assembly from coil by removing 4 screws.
 - b. Remove coil drip flanges from A-coil and reinstall on right side of coil (same side as horizontal drain pan).
 - c. Remove filler plate (A) and install air splitter (B) in place of filler plate.
 - d. Install filler plate (A) as shown in horizontal right application.
 - e. Remove condensate troughs (C) and install on opposite tube sheets.
 - f. Install hose onto plastic spout.
7. Install horizontal pan on right side of coil assembly.
8. Slide coil assembly into casing. Be sure coil bracket on each corner of vertical pan engages coil support rails.
9. Reinstall 2 snap-in clips to correctly position and secure coil assembly in unit. Be sure clip with large offsets is used on right side of unit to secure horizontal pan.
10. Remove 2 oval coil access panel plugs and reinstall into holes on left side of coil access panel and fitting panel.
11. Remove insulation knockouts on right side of coil access panel
12. Reinstall access fitting panels, aligning holes with tubing connections and condensate pan connections. Be sure to reinstall metal clip between fitting panel and vertical condensate pan.
13. After brazing, make sure liquid and suction tube grommets are in place to prevent air leaks and cabinet sweating.

Figure 5

Conversion for Horizontal Right Applications - A-Coil

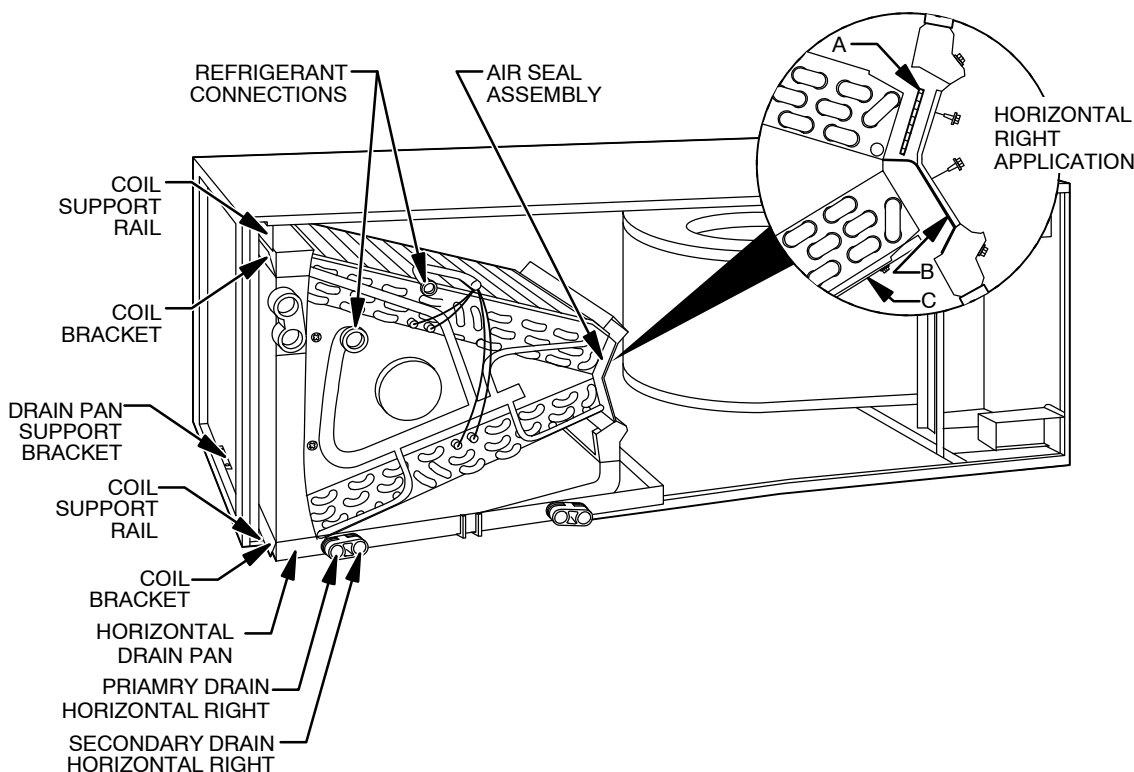

E. MANUFACTURED HOUSING AND MOBILE HOME APPLICATIONS

1. Fan coil unit must be secured to the structure using field-supplied hardware.
2. Allow a minimum of 24 inches (610mm) clearance from access panels.
3. Recommended method of securing for typical applications:
 - a. If fan coil is away from wall, attach pipe strap to top of fan coil using No. 10 self tapping screws. Angle strap down and away from back of fan coil, remove all slack, and fasten to wall stud of structure using 5/16" lag screws. Typical both sides of fan coil.
 - b. If fan coil is against wall, secure fan coil to wall stud using 1/8" (3mm) wide right-angle brackets. Attach brackets to fan coil using No. 10 self tapping screws and to wall stud using 5/16" lag screws (refer to **Figure 6**).

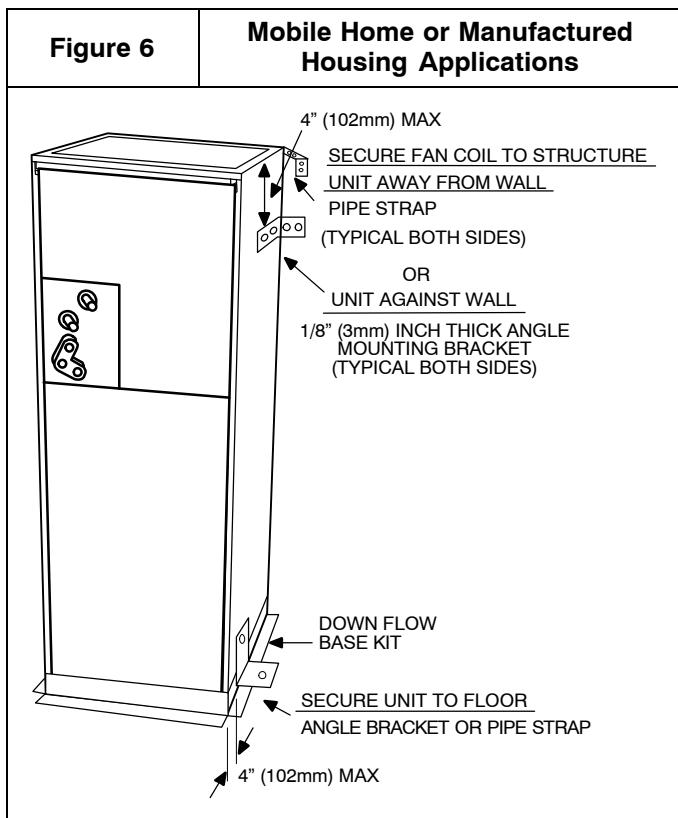

AIR DUCTS

Connect supply-air duct over the outside of 3/4" flanges provided on supply-air opening. Secure duct to flange using proper fasteners for type of duct used, and seal duct-to-unit joint.

It is a recommendation, but not a requirement, to use flexible connections between ductwork and unit to prevent transmission of vibration. When electric heater is installed, use heat-resistant material for flexible connector between duct work and unit at discharge connection. Duct work passing through unconditioned space must be insulated and covered with vapor barrier.

Duct work Acoustical Treatment

Metal duct systems that do not have a 90 degree elbow and 10 feet of main duct before first branch takeoff may require internal acoustical insulation lining. As an alternative, fibrous duct work may be used if constructed and installed in accordance with the latest edition of SMACNA construction standard on fibrous glass ducts. Both acoustical lining and fibrous duct work shall comply with National Fire Protection Association as tested by UL Standard 181 for Class 1 air ducts.

ELECTRICAL CONNECTIONS

REM4P and REM4X Fan Coil models do not have a printed circuit board (PCB), they have a low voltage circuit protective fuse (3 amp) inline on the wire harness. Speed selections are made at the fan motor with the Blue wire. The motor is preprogrammed with the time-delay circuit on some of the speed taps. (See Section D)

Before proceeding with electrical connections, make certain that supply voltage, frequency, phase, and circuit ampacity are as specified on the unit rating plate. See unit wiring label for proper field high and low voltage wiring.

⚠ WARNING

ELECTRICAL SHOCK or UNIT DAMAGE HAZARD

Failure to follow this warning could result in personal injury, death, and/or unit damage.

If a disconnect switch is to be mounted on unit, select a location where drill and fasteners will not contact electrical or refrigeration components.

Make all electrical connections in accordance with the NFPA 70-2011 or current Edition and any local codes or ordinances that may apply. Use copper wire only. The unit must have a separate branch electric circuit with a field-supplied disconnect switch located within sight from and readily accessible from the unit.

NOTE: When a pull-out type disconnect is removed from the unit, only the Load side of the circuit is de-energized. The Line side remains live until the main (remote) disconnect is turned off.

⚠ WARNING

ELECTRICAL SHOCK HAZARD

Failure to follow this warning could result in personal injury or death.

Turn off the main (remote) disconnect device before working on incoming (field) wiring . Incoming (field) wires on the line side of the disconnect found in the fan coil unit remain live, even when the pull-out is removed. Service and maintenance to incoming (field) wiring cannot be performed until the main disconnect switch (remote to the unit) is turned off.

A. LINE VOLTAGE CONNECTIONS

Fan Coils installed without electric heat require the use of a factory–authorized Power Plug Kit (accessory part number EBAC01PLG). This kit provides the electrical connections necessary to supply the unit with 208/230V power when electric heat is not present. For units without electric heat:

1. Connect 208/230V power leads from field disconnect to yellow and black stripped leads on Power Plug (accessory part number EBAC01PLG).
2. Connect ground wire to unit ground lug.
3. When installing an electric heater, remove and discard power plug (if equipped) from fan coil and connect male plug from heater to female plug from unit wiring harness. (See Electric Heater Installation Instructions.)

B. 24V CONTROL SYSTEM

Connection to Unit

Wire low voltage in accordance with wiring label on the blower (also refer to **Figure 7** through **Figure 12**). Use 18 AWG color-coded, insulated (35 °C minimum) wire to make the low-voltage connections between the thermostat, the unit, and the outdoor equipment. If the thermostat is located more than 100 feet from the unit (as measured along the low voltage wire), use 16 AWG color-coded, insulated (35 °C minimum) wire. All wiring must be NEC Class 2 and must be separated from incoming power leads. Refer to outdoor unit wiring instructions for additional wiring recommendations.

Heater Staging

The controls are factory circuited for single-stage operation (refer to **Figure 8**). When 2 stages are desired, cut W3 at the W2 wire nut, strip, and reconnect according to the thermostat kit instruction (refer to **Figure 10** – outdoor thermostat optional). When 3 stages are desired, cut the W2 wire nut off and discard. Strip W2, W3, and E, and reconnect according to the thermostat kit instructions (refer to **Figure 11** outdoor thermostats optional).

that supplemental electric heat be locked out at outdoor temperatures above 40°F (4°C), except for a heat pump defrost cycle. Refer to **Figure 12** for typical low voltage wiring with outdoor thermostat.

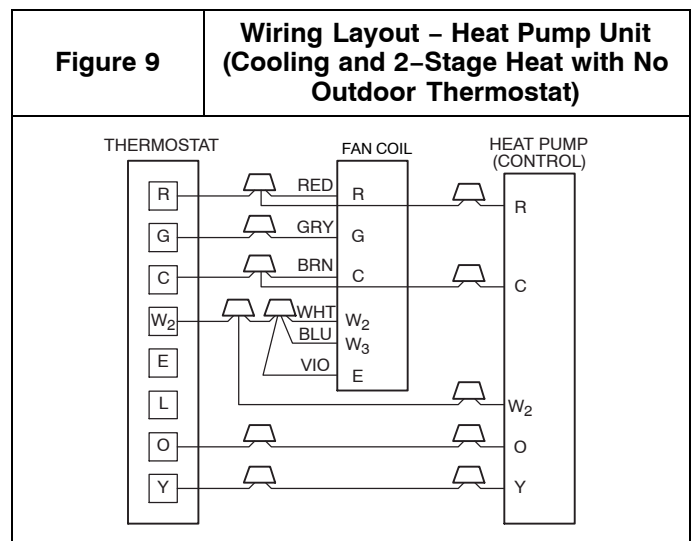
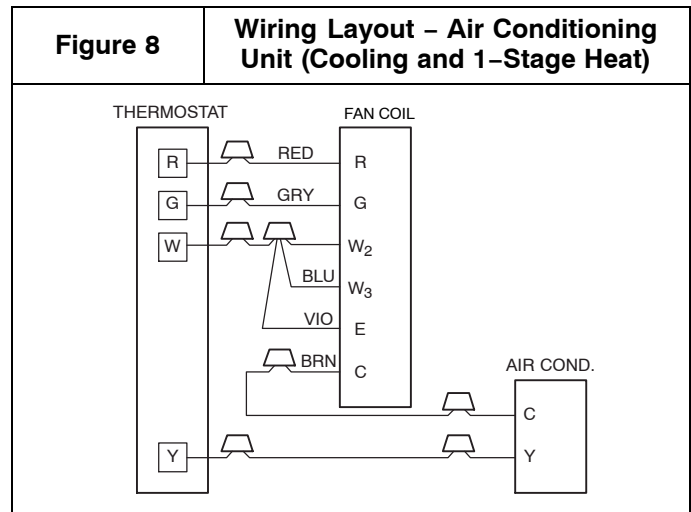
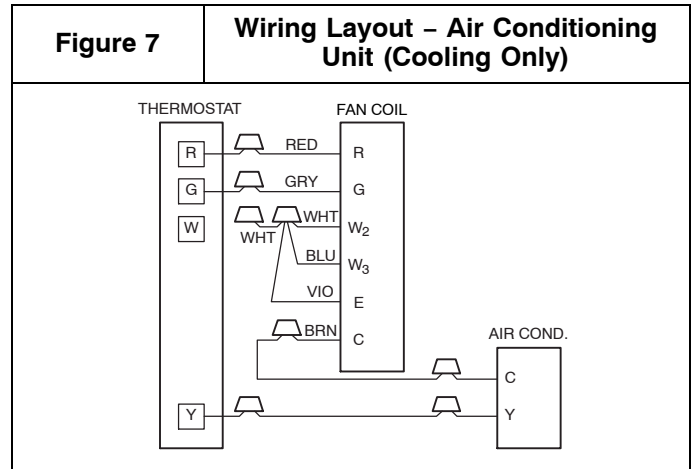

⚠ CAUTION

UNIT OPERATION HAZARD

Failure to follow this caution may result in improper product operation.

If W2, W3, and E on any 3 stage heater (18, 20, 24, or 30kW) are individually connected – as with outdoor thermostats or any other situation – emergency heat relay must be used. If relay is not used, blower may not operate when heaters are energized.

Manufactured Housing

In manufactured housing applications, the Code of Federal Regulations, Title 24, Chapter XX, Part 3280.714 requires

Figure 10 Wiring Layout – Heat Pump Unit (Cooling and 2-Stage Heat with One Outdoor Thermostat)

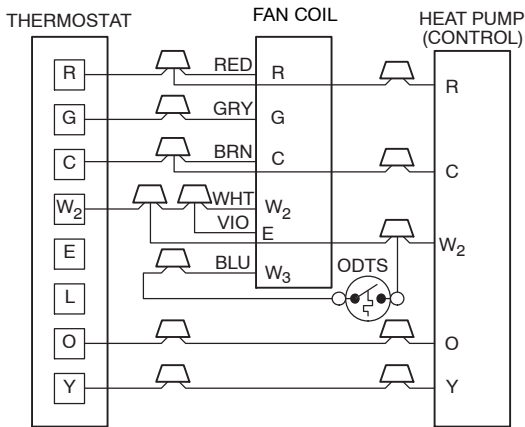

Figure 11 Wiring Layout – Heat Pump Unit (Cooling and 2-Stage Heat with Two Outdoor Thermostats)

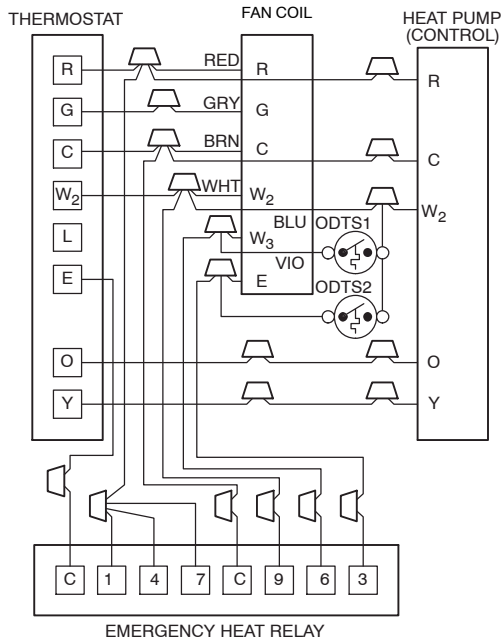
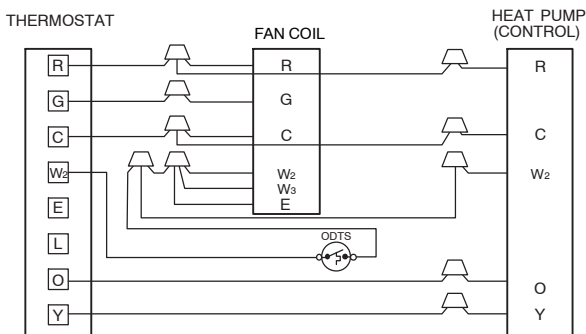

Figure 12 Wiring Layout – Heat Pump Unit (Cooling and 2-Stage Heat for Manufactured Housing)



Transformer Information

Transformer is factory wired for 230V operation. For 208V applications, disconnect the black wire from the 230V terminal on transformer and connect it to the 208V terminal (refer to **Figure 13**).

Figure 13 Transformer Connections

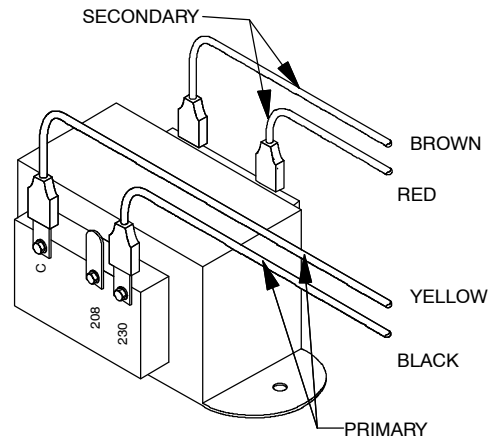

C. GROUND CONNECTIONS

⚠ WARNING

ELECTRICAL SHOCK HAZARD

Failure to establish uninterrupted or unbroken ground could result in personal injury and/or death.

According to NFPA 70-2011, and local codes, the cabinet must have an uninterrupted or unbroken ground in order to minimize potential for personal injury or death if an electrical fault should occur. The ground may consist of electrical wire or metal conduit when installed in accordance with existing electrical codes. If conduit connection uses reducing washers, a separate ground wire must be used.

NOTE: Use UL listed conduit and conduit connectors for connecting supply wire(s) to unit to obtain proper grounding. Grounding may also be accomplished by using grounding lugs provided in control box.

D. MINIMUM CFM AND MOTOR SPEED SELECTION

Units with or without electric heaters require a minimum CFM. Refer to the unit wiring label to ensure that the fan speed selected is not lower than the minimum fan speed indicated.

NOTE: In low static applications, lower motor speed tap should be used to reduce possibility of water being blown off coil.

REM4P and REM4X fan speed is selected at the motor connector. Units with or without electric heaters require a minimum CFM. Refer to the unit wiring label to ensure that the fan speed selected is not lower than the minimum fan speed indicated.

SPEED TAP SELECTION AT MOTOR CONNECTOR		
Tap 1	Low	90 sec off delay
Tap 2	Medium	90 sec off delay
Tap 3	High	90 sec off delay
Tap 4	Electric Heat †	0 sec off delay
Tap 5	Max ‡	0 sec off delay

† Electric heat airflow is same CFM as Tap 3, but with 0 sec off delay.

‡ For high static applications, see Airflow Performance Tables for max airflow.

To change motor speeds disconnect the BLUE fan lead from motor connector terminal #2 (factory default position) and move to desired speed-tap; 1, 2, 3, or 5.

Speed-taps 1, 2, and 3 have a 90 second blower off time delay pre-programmed into the motor. Speed tap 4 is used for electric heat only (with 0 second blower time delay) and the WHITE wire should remain on tap 4. Speed-tap 5 is used for high static applications, but has a 0 second blower time delay pre-programmed into the motor (see Airflow Performance Tables for actual CFM for each tap). Also, see **Figure 14** for motor speed selection location.

NOTE: In low static applications, lower motor speed tap should be used to reduce possibility of water being blown off coil.

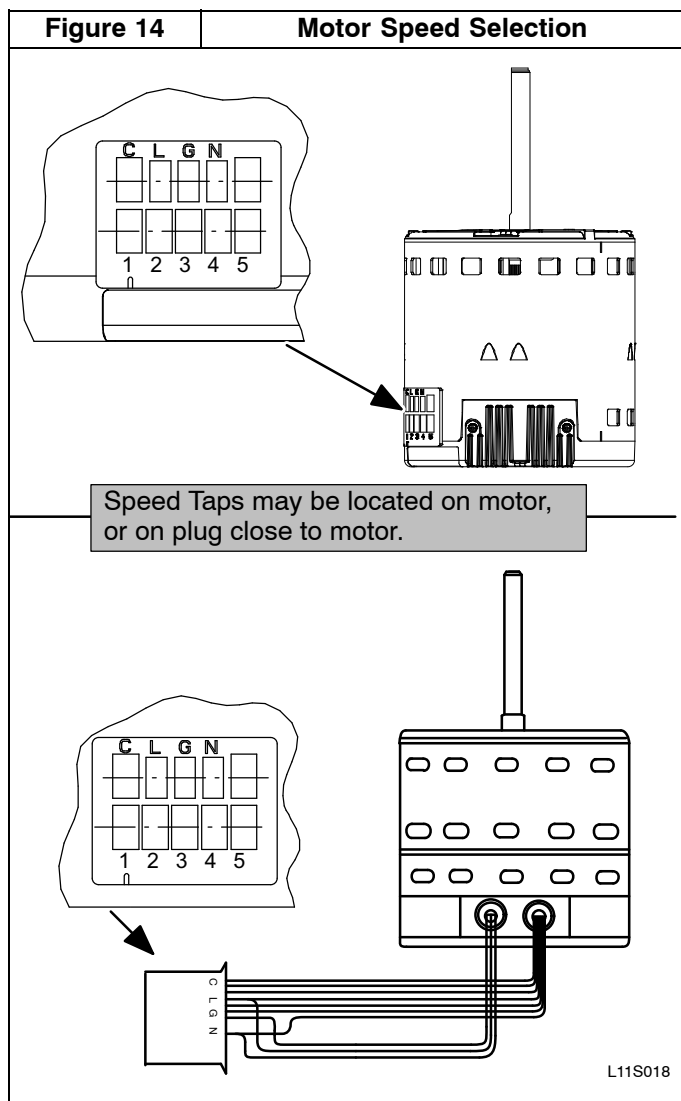

REFRIGERANT TUBING

Refrigerant Tubing Connection and Evacuation
Use accessory tubing package or field-supplied tubing of refrigerant grade. Suction tube must be insulated. Do not use damaged, dirty, or contaminated tubing because it may plug refrigerant flow-control device. ALWAYS evacuate the coil and field-supplied tubing to 500 microns before opening outdoor unit service valves.

CAUTION

PRODUCT DAMAGE HAZARD

Failure to follow this caution may result in product or property damage.

A brazing shield **MUST** be used when tubing sets are being brazed to the unit connections to prevent damage to the unit surface and condensate pan fitting caps.

Units have sweat suction and liquid tube connections. Make suction tube connection first.

1. Cut tubing to correct length.
2. Insert tube into sweat connection on unit until it bottoms.
3. Braze connection using silver bearing or non-silver bearing brazing materials. Do not use solder (materials which melt below 800°F / 427°C). Consult local code requirements.
4. Evacuate coil and tubing system to 500 microns using deep vacuum method.

Size and install refrigerant lines according to information provided with outdoor unit. Route refrigerant lines to the fan coil in a manner that will not obstruct service access to the unit or removal of the filter.

1. Find the liquid tube grommet in the small-parts bag and slide it onto the liquid refrigerant line (field line-set).
2. Remove the lower door. Remove the tubing plate (with suction tube grommet) and slide the plate with grommet onto the refrigerant lines (field line-set), away from braze joints.
3. Remove rubber plugs from coil stubs using a pulling and twisting motion. Hold coil stubs steady to avoid bending or distorting.
4. Wrap TXV and nearby tubing with a heat-sinking material such as a wet cloth.
5. Fit refrigerant lines into coil stubs. Wrap a heat sinking material such as a wet cloth behind braze joints.
6. Braze using a Sil-Fos or Phos-copper alloy.
7. After brazing, allow joints to cool. Slide tubing plate back into place and position grommets around suction and liquid tubes to ensure air seal.



CAUTION

PRODUCT DAMAGE HAZARD

Failure to follow this caution may result in product or property damage.

Wrap a wet cloth around rear of fitting to prevent damage to piston assembly or TXV and factory-made joints.

REFRIGERANT FLOW-CONTROL DEVICE

REM4P models come equipped with a factory installed Piston metering device with Teflon ring. If a piston replacement is required, check piston size shown on indoor unit rating plate to see if it matches required piston shown on outdoor unit rating plate. If it does not match, replace indoor piston with piston shipped with outdoor unit. The piston shipped with outdoor unit is correct for any approved indoor coil combination (See **Figure 15**).

When changing piston, use a back-up wrench. Hand tighten hex nut, then tighten with wrench 1/2 turn. Do not exceed 30 ft-lbs. The indoor piston contains a Teflon ring (or seal) which is used to seat against the inside of distributor body, and must be installed properly to ensure proper seating in the direction for cooling operation.



CAUTION

PRODUCT OPERATION HAZARD

Failure to follow this caution may result in improper product operation.

If using a TXV in conjunction with a single-phase reciprocating compressor, a compressor start capacitor and relay are required. Consult outdoor unit pre-sale literature for start assist kit part number.

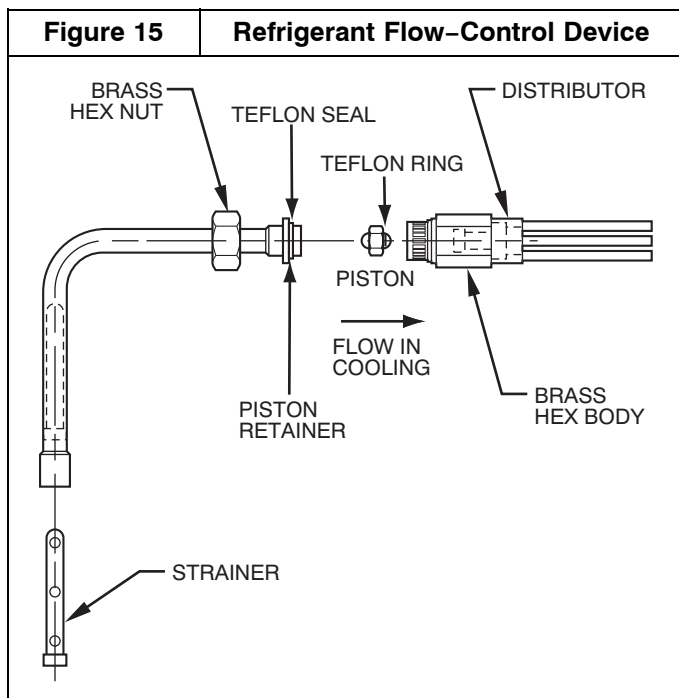

REFRIGERANT METERING DEVICE

REM4X models have a factory installed hard shut-off TXV designed only for use with R-410A refrigerant. Use only with outdoor units designed for R-410A.

TXV is factory set and not field adjustable.



CAUTION

PRODUCT DAMAGE HAZARD

Failure to follow this caution may result in product damage.

This Fan Coil has a hard shut-off TXV metering device. A compressor Hard Start Kit is **REQUIRED** in all applications where the matching outdoor unit has a single-phase reciprocating compressor.

CONDENSATE DRAINS

Unit is provided with primary and secondary 3/4" (19mm) NPT drain connections. Refer to **Figure 1**, **Figure 2**, **Figure 3**, **Figure 4**, and **Figure 5** to identify the primary and secondary locations. To prevent property damage and achieve optimum drainage performance, **BOTH** primary and secondary drain lines should be installed and include properly sized condensate traps (refer to **Figure 16**). Factory approved condensate traps are available (accessory part number EBAC01CTK).

To connect drain lines, the drain connection knock-outs must be removed. Use a knife to start the opening near the tab and using pliers, pull the tab to remove the knock-out. Clean the edge of the opening if necessary. After drain fittings are installed, caulk the seam between the fitting and the cover to retain the low leak rating of the unit.

It is recommended the PVC fittings be used on the plastic condensate pan. Do not over-tighten. Finger-tighten plus 1-1/2 turns. Use pipe dope, to ensure proper seal.

Install traps in the condensate lines as close to the coil as possible (refer to **Figure 18**), but avoid blocking filter access panel.

Install drain lines below the bottom of the drain pan and pitch the drain lines down from the coil at least 1/4 inch per foot of run (6mm per 0.3m). Horizontal runs over 15 feet (5m) long must also have an anti-siphon air vents (stand pipes), installed ahead of the horizontal runs. Extremely long horizontal runs may require oversized drain lines to eliminate air trapping.

Route primary drain line to the outside or to a floor drain. Check local codes before connecting to a waste (sewer) line.

Route the secondary drain line to a place in compliance with local installation codes where it will be noticed when unit is operational. Condensate flowing from secondary (overflow) drain indicates a plugged primary drain - unit requires service or water damage will occur.

Prime all traps, test for leaks, and insulate in areas where sweating of the traps and drain lines could potentially cause water damage. Consult local codes for additional requirements or precautions.

If a gravity drain cannot be used, install a condensate pump. Install the pump as close to the indoor section as possible.

⚠ CAUTION

PRODUCT or PROPERTY DAMAGE HAZARD

Failure to follow this caution may result in product or property damage.

Use only full size P-traps in the condensate line (refer to **Figure 16**). Shallow, running traps are inadequate and **DO NOT** allow proper condensate drainage (refer to **Figure 17**).

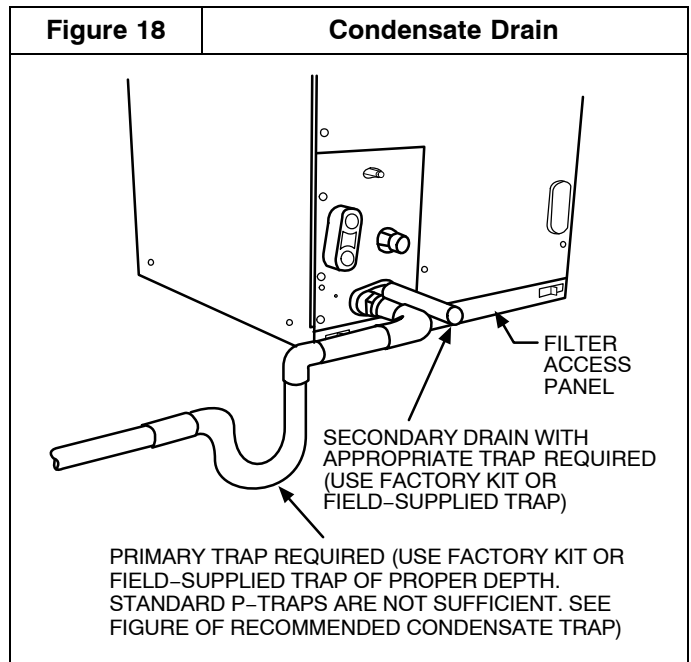
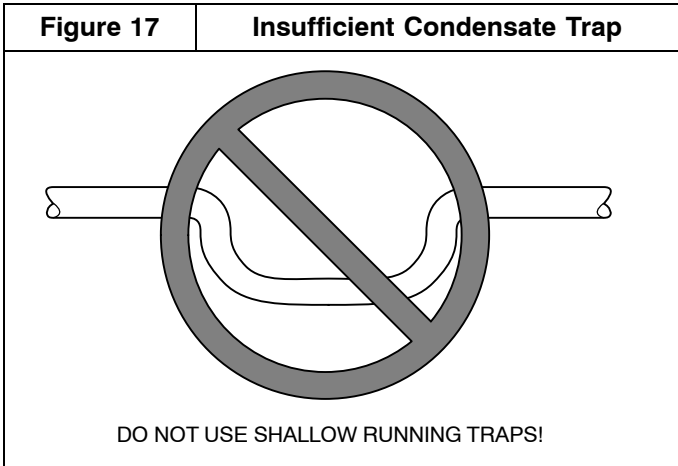
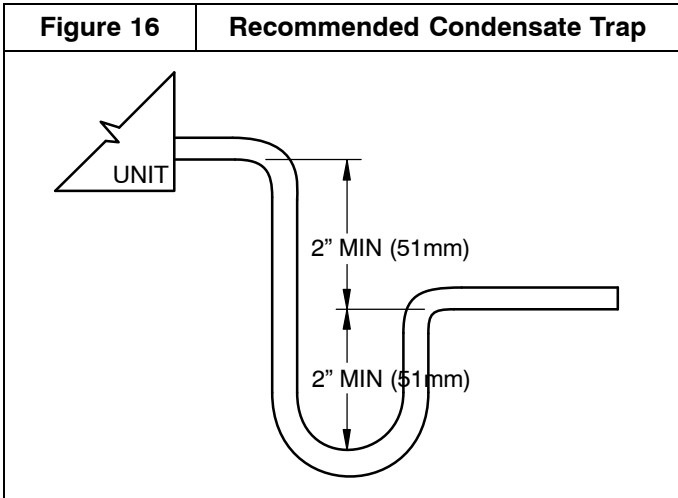

ACCESSORIES

A. ELECTRONIC AIR CLEANER

The Electronic Air Cleaner may be connected to fan coils. See Electronic Air Cleaner literature for kit requirements and installation.

B. HUMIDIFIER

Connect humidifier and humidistat to fan coil unit as shown in **Figure 19** and **Figure 20**.

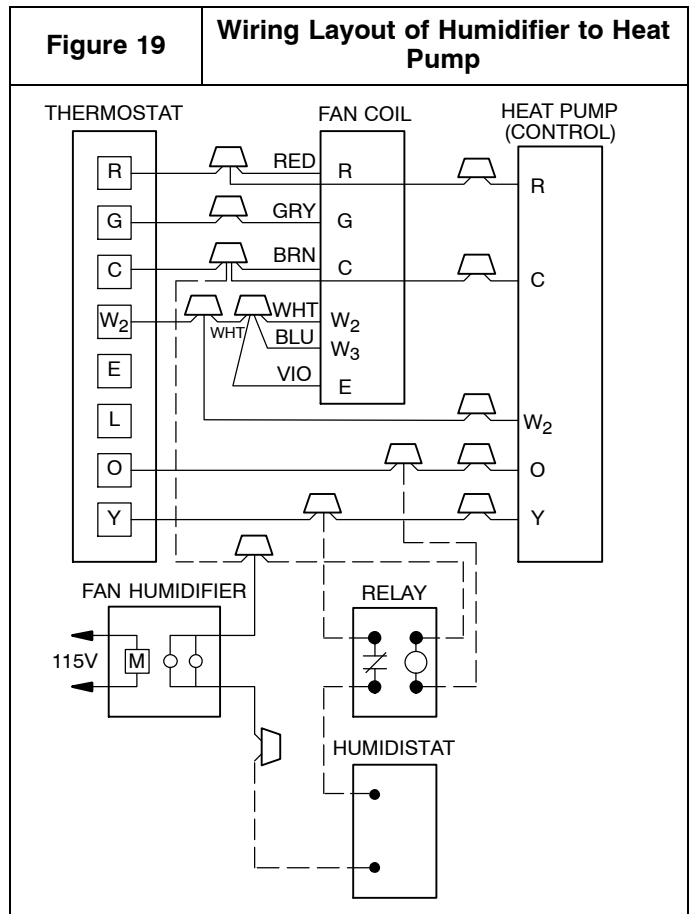
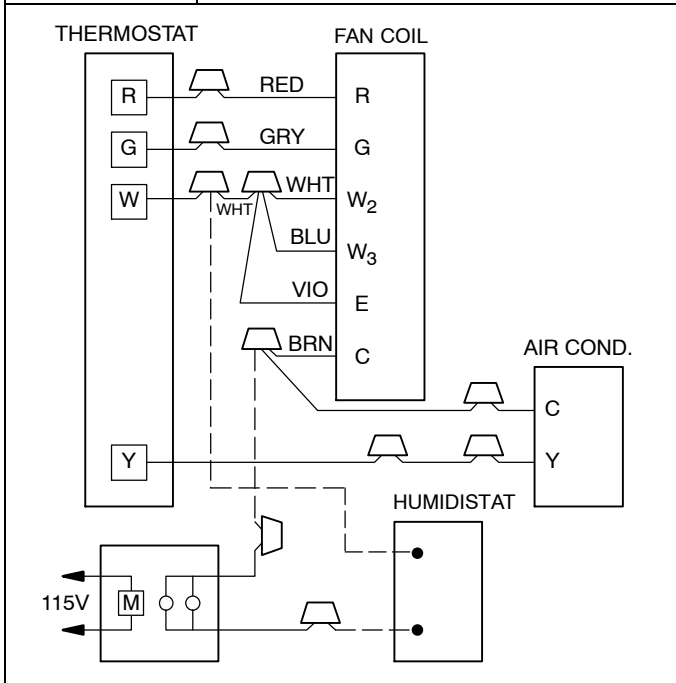

Figure 20

Wiring Layout of Humidifier to Fan Coil with Electric Heat



SEQUENCE OF OPERATIONS

A. CONTINUOUS FAN

Thermostat closes R to G. G sends signal direct to motor which completes circuit to indoor blower motor. When G is de-energized, there is a 90 second off delay before relay opens, (Based on speed tap selected).

B. COOLING MODE

Thermostat energizes R to G, R to Y, and R to O (heat pump only). G sends signal direct to motor which completes circuit to indoor blower motor. When G is de-energized, there is a 90 second off delay before fan relay opens (Based on speed tap selected).

C. HEAT PUMP HEATING MODE

Thermostat energizes R to G and R to Y. G sends signal direct to motor which completes circuit to indoor blower motor. When G is de-energized, there is a 90 second off delay before fan relay opens, (Based on speed tap selected)

D. HEAT PUMP HEATING WITH AUXILIARY ELECTRIC HEAT

Thermostat energizes R to G, R to Y, and R to W. G completes circuit to indoor blower motor. W completes

circuit to heater element(s). When W is de-energized, electric heat relay(s) open, turning off heater elements. When G is de-energized there is a 90 second off delay before fan relay opens, (Based on speed tap selected)

E. ELECTRIC HEAT OR EMERGENCY HEAT MODE

Thermostat closes R to W. W which completes circuit to heater element(s). Blower motor is energized through normally closed contacts on fan relay. When W is de-energized, electric heat relay(s) opens.

START-UP PROCEDURE

Refer to outdoor unit Installation Instructions for system start-up instructions and refrigerant charging method details.

CARE AND MAINTENANCE

The system should be regularly inspected by a qualified service technician. Consult the servicing dealer for recommended frequency.

Between visits, the only consumer service recommended or required is air filter maintenance and condensate drain operation.

Air Filter

Inspect air filters at least monthly and replace or clean as required. Disposable type filters should be replaced. Reusable type filters may be cleaned by soaking in mild detergent and rinsing with cold water. Install filters with the arrows on the side pointing in the direction of air flow.

Condensate Drain

During the cooling season check at least monthly for free flow of drainage and clean if necessary.



CAUTION

PRODUCT DAMAGE HAZARD

Failure to follow this caution may result in poor unit performance and/or product damage.

Never operate unit without a filter. Factory authorized filter kits must be used when locating the filter inside the unit. For those applications where access to an internal filter is impractical, a field-supplied filter must be installed in the return duct system.

AIRFLOW PERFORMANCE – CFM at a given Speed and Static reading

Model	Blower Speed	Total Static (inches water column)					
		0.10	0.20	0.30	0.40	0.50	0.60
REM4P24	Tap 5	969	936	892	835	763	676
	Tap 4	826	795	766	743	706	660
	Tap 3	826	795	766	743	706	660
	Tap 2	701	660	616	581	537	499
	Tap 1	617	592	552	507	472	420
REM4P36	Tap 5	1301	1276	1245	1218	1176	1121
	Tap 4	1227	1191	1169	1143	1105	1074
	Tap 3	1227	1191	1169	1143	1105	1074
	Tap 2	1087	1062	1030	1001	966	930
	Tap 1	1026	1000	969	938	899	865
REM4P48	Tap 5	1743	1712	1679	1642	1610	1574
	Tap 4	1669	1634	1599	1564	1531	1499
	Tap 3	1669	1634	1599	1564	1531	1499
	Tap 2	1452	1413	1377	1339	1308	1271
	Tap 1	1300	1256	1221	1182	1142	1101
REM4X60	Tap 5	1897	1867	1836	1808	1774	1736
	Tap 4	1817	1785	1757	1724	1693	1655
	Tap 3	1817	1785	1757	1724	1693	1655
	Tap 2	1657	1621	1589	1557	1518	1474
	Tap 1	1443	1412	1377	1332	1286	1243

— Airflow outside 450 cfm/ton.

NOTES:

1. Airflow based upon dry coil at 230v with factory-approved filter and electric heater (2 element heater sizes 24 through 36, 3 element heater sizes 48 through 60). For REM4P models, airflow at 208 volts is approximately the same as 230 volts because the ECM motor is a constant torque motor. The torque doesn't drop off at the speeds the motor operates.
2. To avoid potential for condensate blowing out of drain pan prior to making drain trap:
Return static pressure must be less than 0.40 in. w.c..
Horizontal applications of 48 – 60 sizes must have supply static greater than 0.20 in. w.c..
3. Airflow above 400 cfm/ton on 48 – 60 size could result in condensate blowing off coil or splashing out of drain pan.

Table 1 – Air Delivery Performance Correction Component Pressure Drop (in. w.c.) at Indicated Airflow (Dry to Wet Coil)

UNIT SIZE	CFM															
	500	600	700	800	900	1000	1100	1200	1300	1400	1500	1600	1700	1800	1900	2000
24	0.034	0.049	0.063	0.076	0.089	—	—	—	—	—	—	—	—	—	—	—
36	—	—	—	—	—	0.070	0.080	0.090	0.099	—	—	—	—	—	—	—
48	—	—	—	—	—	—	—	—	—	0.063	0.070	0.076	0.083	0.090	—	—
60	—	—	—	—	—	—	—	—	—	—	—	0.049	0.054	0.059	0.065	0.070

Table 2 – Electric Heater Static Pressure Drop (in. w.c.)

UNIT SIZE	CFM								
	400	600	800	1000	1200	1400	1600	1800	2000
24	0.020	0.044	0.075	--	--	--	--	--	--
36	--	--	0.048	0.072	0.100	--	--	--	--
48, 60	--	--	--	--	0.070	0.092	0.120	0.152	--

Table 3 – Electric Heater Static Pressure Drop (in. w.c.)

24 – 36			48 – 60		
HEATER ELEMENTS	kW	EXTERNAL STATIC PRESSURE CORRECTION	HEATER ELEMENTS	kW	EXTERNAL STATIC PRESSURE CORRECTION
0	0	+.02	0	0	+.04
1	3, 5	+.01	2	8, 10	+.02
2	8, 10	0	3	9, 15	0
3	9, 15	-.02	4	20	-.02
4	20	-.04	6	18, 24, 30	-.10

R-410A QUICK REFERENCE GUIDE

- R-410A refrigerant operates at 50% – 70% higher pressures than R-22. Be sure that servicing equipment and replacement components are designed to operate with R-410A.
- R-410A refrigerant cylinders are rose colored.
- Recovery cylinder service pressure rating must be 400 psig, DOT 4BA400 or DOT BW400.
- R-410A systems should be charged with liquid refrigerant. Use a commercial type metering device in the manifold hose.
- Manifold sets should be 750 psig high-side and 200 psig low-side with 520 psig low-side retard.
- Use hoses with 750 psig service pressure rating.
- Leak detectors should be designed to detect HFC refrigerant.
- R-410A, as with other HFC refrigerants, is only compatible with POE oils.
- POE oils absorb moisture rapidly. Do not expose oil to atmosphere.
- POE oils may cause damage to certain plastics and roofing materials.
- Vacuum pumps will not remove moisture from oil.
- A liquid line filter-drier is required on every unit.
- Do not use liquid line filter-driers with rated working pressures less than 600 psig.
- Do not install a suction line filter-drier in liquid line.
- Wrap all filter-driers and service valves with wet cloth when brazing.
- Do not use capillary tube indoor coils.
- Never open system to atmosphere while it is under a vacuum.
- When system must be opened for service, break vacuum with dry nitrogen and replace all filter-driers.
- Do not vent R-410A into the atmosphere.
- Observe all **WARNINGS**, **CAUTIONS**, **NOTES**, and **bold** text.
- Do NOT use R-22 TXV.