

INSTALLATION INSTRUCTIONS

TXV Horizontal Duct Coils

EHD

These instructions must be read and understood completely before attempting installation.

It is important that the Blower and Duct System be properly sized to allow the system to operate at full capacity. Poorly designed systems will not give satisfactory cooling or economy. They may even shorten the service life of the compressor in the outdoor unit.

TABLE OF CONTENTS

	PAGE
SAFETY CONSIDERATIONS	1
INTRODUCTION	2
INSTALLATION	2
Step 1- Check Existing Duct work	2
Step 2- Insulate and Vapor-proof Duct	2
Step 3- Install Coil in Supply Air Duct	2
Step 4- Connect Refrigerant Piping	2
Step 5- Connect Refrigerant, Liquid, & Suction Lines	2
REFRIGERANT METERING DEVICE	3
Step 1- Connect Condensate Lines	3
MAINTENANCE	4
Air Filter	4
Condensate Pan and Drain	4
Cleaning Coil	4
Airflow vs CFM Chart	5
R-14A Quick Reference Guide	6

SAFETY CONSIDERATIONS

Improper installation, adjustment, alteration, service, maintenance, or use can cause explosion, fire, electrical shock or other conditions which may cause death, personal injury or property damage. Consult a qualified installer, service agency, or your distributor or branch for information or assistance. The qualified installer or agency must use factory-authorized kits or accessories when modifying this product. Refer to the individual instructions packaged with the kits or accessories when installing.

Follow all safety codes. Wear safety glasses, protective clothing and work gloves. Use quenching cloths for brazing operations. Have fire extinguisher available. Read these instructions thoroughly and follow all warnings or cautions attached to the unit. Consult local building codes and the current editions of the National Electrical Codes (NEC) NFPA 70.

In Canada, refer to the current editions of the Canadian Electrical Code CSA C22.1.

Recognize safety information. This is the safety-alert symbol . When you see this symbol on the unit and in instructions or manuals, be alert to the potential for personal injury.

Understand the signal words **DANGER**, **WARNING** and **CAUTION**. These words are used with the safety-alert symbol. **DANGER** identifies the most serious hazards which **will** result in severe personal injury or death. **WARNING** signifies hazards which **could** result in personal injury or death. **CAUTION** is used to identify unsafe practices, which **may** result in minor personal injury or product and property damage. **NOTE** is used to highlight suggestions which **will** result in enhanced installation, reliability, or operation.

 **WARNING**

ELECTRICAL SHOCK HAZARD

Failure to follow this warning could result in personal injury or death

Before installing, modifying or servicing, always turn off main power to system. There may be more than one disconnect switch. Lock out and tag switch with a suitable warning label.

 **CAUTION**

PERSONAL INJURY HAZARD

Failure to follow this caution may result in personal injury.

This coil contains Nitrogen precharge of 15 PSIG Release of this pressure through the center of the Schrader port is required before removing the port

 **CAUTION**

CUT HAZARD

Failure to follow this caution may result in personal injury.

Sheet metal parts may have sharp edges or burrs. Use care and wear appropriate protective clothing and gloves when handling parts.

IMPORTANT: Nitrogen can leak out through the plug or

Schrader port (depending on which is installed on the coil). This does not indicate a leaking coil nor warrant return of coil.

INTRODUCTION

Use these instructions to install Model EHD duct coils in horizontal position. (See Fig. 1.) It is easily adaptable to most types of existing forced-air heating systems, or can be installed in an independent air-cooling system.

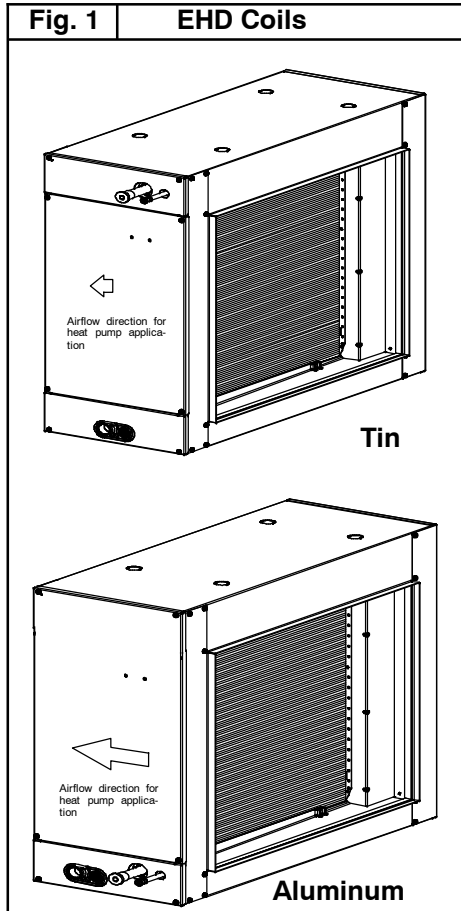

INSTALLATION

Step 1 — Check Existing Duct work

Inspect the previously installed air distribution system for heating to determine its suitability for cooling.

Step 2 — Insulate and Vapor-proof Duct

Externally insulated duct work must have an adequate vapor seal for summer operation. This is particularly important where the duct is exposed to high humidity conditions in attics, vented crawl spaces, unconditioned basements and utility rooms. The vapor seal prevents condensation in the insulating material and subsequent loss of insulating value. Properly installed heating supply ducts should already have adequate insulation against excessive heat loss. This same insulation should, therefore, be satisfactory in the summer for protection against heat gain. However, depending on the specific installation, it may be desirable to add to the insulation.

Step 3 — Install Coil in Supply Air Duct

NOTE: For cooling-only units, coil can be installed in either airflow direction. Heat pump applications require Specific airflow direction to obtain performance. See Fig. 1. Check for and remove any shipping blocks on

the header side of the coil prior to installation.

1. When the connecting air supply duct is smaller than the coil inlet opening, construct transition piece so that vertical and horizontal dimensions of transition piece do not increase more than 30° angle. If connecting outlet duct is smaller than outlet opening of coil, limit transition to maximum of 45° angle.

2. Provide at least 3 ft (.9m) of straight duct work – preceding coil inlet.

3. Support coil from floor or suspend it. When coil is suspended, provide adequate hangers to hold coil.

NOTE: When coil is installed over a finished ceiling or living area, a secondary condensate pan must be constructed and installed under entire coil section.

Step 4 — Connect Refrigerant Piping

Use field-supplied, refrigerant-grade tubing for connection to outdoor units. Suction tube must be insulated. Do not use damaged, dirty, or contaminated tubing because it may plug.

Step 5 — Connect Refrigerant, Liquid, and Suction Lines

For matched and mismatched systems, use line sizes recommended in outdoor unit Installation Instructions. The coil can be connected to outdoor units using accessory tubing packages or field-supplied tubing of refrigerant grade. Always evacuate tubing and reclaim refrigerant when making connections or flaring tubing. Leak check connections before insulating entire suction line.

1. Remove middle cabinet cover. Remove tubing cover and slide cover with grommets onto the refrigerant lines (field line set), away from braze joints.

2. On coils with plugs:

Remove rubber plugs from coils tubes using a pulling and twisting motion. Hold coil plugs steady to avoid bending or distorting.

On coils with Schrader ports:

Relieve pressure by depressing the valve. Remove valve body by cutting the belled area with a pipe cutter close to the valve body leaving sufficient beelling to connect the line set. Hold coil stub steady to avoid bending or distorting.

3. Wrap TXV and nearby tubing with a heat-sinking material, such as a wet cloth.

4. Fit refrigerant lines into coil stubs. Wrap a heat-sinking material, such as a wet cloth, behind braze joints.

5. Braze using a Sil-Fos or Phos-Copper alloy.

6. After brazing, allow joints to cool. Slide tubing plate with rubber grommets over joints. Position tubing at center of each grommet to ensure an air seal around the tube.

See Table 1 for coil connection tube size.

Table 1 - Coil Connection Sizes

MODEL SIZE	TONNAGE	COIL CONNECTION TUBE SIZE(IN.)	
		LIQUID	SUCTION
24	2	3/8	5/8
30	2 - 1/2	3/8	3/4
36	3	3/8	3/4
42	3 - 1/2	3/8	7/8
48	4	3/8	7/8
60	5	3/8	7/8

⚠ CAUTION

UNIT DAMAGE HAZARD
Failure to follow this caution may result in product damage.
To avoid damage while brazing, wrap tubing or fitting with a heat-sinking material, such a wet cloth.

REFRIGERANT METERING DEVICE

These coils have a factory-installed hard-shutoff TXV designed only for use with R-410A refrigerant. Use only with outdoor units designed for R-410A.

NOTE: ALL TXV'S HAVE PRESET SUPERHEAT SETTINGS AND ARE FIELD **NON-ADJUSTABLE**.

CONDENSATE DRAIN LINE CONNECTION

⚠ CAUTION

PROPERTY DAMAGE HAZARD
Failure to follow this caution may result in property damage.
When installing over a finished ceiling and/or living area, install a field-fabricated secondary condensate pan under the entire unit.

The coil is designed to dispose of accumulated water through built-in condensate drain fittings. It is recommended that PVC fittings be used on the condensate pan. Do not over-tighten. Finger tighten plus 1-1/2 turns. Be sure to install plastic plug in unused condensate drain fitting. Two 3/4-in. female threaded pipe connections are provided in each coil condensate pan.

A trap is not necessary on the condensate line. Consult local codes for additional restrictions or precautions. If local codes require a trap then the following guidelines are suggested to assure proper drainage. Install a trap in condensate line of coil as close to the coil as possible. Make trap at least 3 in. (76 mm) deep and no higher than the bot-

tom of unit condensate drain opening (See Fig. 2). Pitch condensate line 1 in. (25.4 mm) for every 10 ft. of length to an open drain or sump. Make sure that the outlet of each trap is below its connection to condensate pan to prevent condensate from overflowing the drain pan. Prime all traps, test for leaks, and insulate traps and lines if located above a living area.

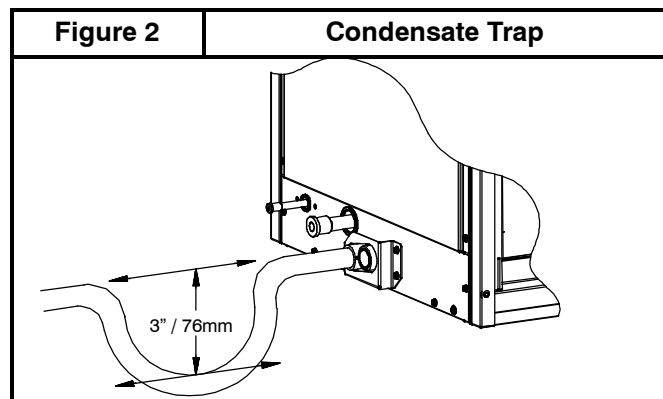

NOTE: If unit is located in or above a living space, where damage may result from condensate overflow, a field-supplied, external condensate pan should be installed underneath the entire unit, and a secondary condensate line (with appropriate trap) should be run from the unit into the pan. Any condensate in this external condensate pan should be drained to a noticeable place. As an alternative to using an external condensate pan, some localities may allow the running of a separate 3/4-in. (19 mm) condensate line (with appropriate trap) per local code to a place where the condensate will be noticeable. The owner of the structure must be informed that when condensate flows from secondary drain or external condensate pan, the unit requires servicing or water damage will occur. To further protect against water damage, install a float switch to shut the unit off if the water in the secondary pan gets too high.

NOTE: To avoid drainage problems, test the primary drain line by slowly pouring water into the pan. Check piping for leaks and proper condensate drainage. Using the secondary drain as explained in the previous note provides further protection against overflow due to a clogged primary drain.

NOTE: In applications where return air humidity levels stay at 70% or above for a prolonged period of time, condensation can form on the bottom of pan and drip.

WASTE LINE CONNECTION

If the condensate line is to be connected to a waste (sewer) line, an open trap must be installed ahead of the waste line to prevent escape of sewer gases (See Fig. 3).

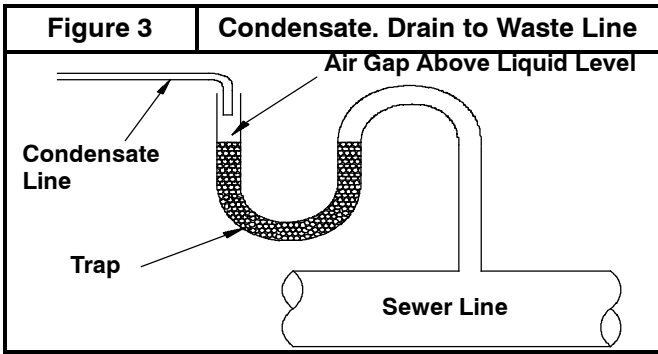

WARNING

EXPLOSION HAZARD
 Failure to follow this warning could result in personal injury or death.
 Provide trap with air gap in drain line when connecting to waste (sewer) line.

MAINTENANCE

To ensure optimum performance and to minimize possible equipment problems, periodic maintenance must be performed on this equipment. Consult your dealer on proper frequency of maintenance and the availability of a maintenance contract. Proper maintenance on this equipment requires certain skills and tools. If you do not possess these, obtain qualified dealer assistance.

WARNING

ELECTRICAL SHOCK HAZARD
 Failure to follow this warning could result in personal injury or death.
 Disconnect all electrical power to air handler (furnace) and outdoor unit before performing any maintenance or service on unit. Units may have more than 1 electrical power supply

Minimum maintenance should be performed on the equipment as follows:

1. Check and clean or replace air filter each month or as required.
2. Check cooling coil, drain pan and condensate drain at start of each cooling season for cleanliness. Clean as needed.

NOTE: Because of possible damage to equipment, or personal injury, maintenance should be performed by qualified persons only.

CAUTION

CUT HAZARD
 Failure to follow this warning could result in personal injury.
 Sheet metal parts may have sharp edges or burrs. Use care and wear appropriate protective clothing and gloves when handling parts.

A. Air Filter

An air filter is not provided as an integral part of this cooling coil. However, a field-supplied filter must be used upstream of the coil and must be inspected frequently. When filter becomes clogged with dust or lint, it should be replaced (disposable type) or cleaned (cleanable type). Inspect filter at least once each month and replace or clean at least twice a year (more often if necessary).

NOTE: Do not operate coil without a filter in place in return-air duct. Always replace filter with same size and type filter.

B. Condensate Pan and Drain

Check drain pan and condensate drain at the same time cooling coil is checked. Clean drain pan and condensate drain thoroughly. Flush pan and drain tube with clear water. If drain tube or trap is restricted, clean with high-pressure water. If this does not work, try a plumber's snake or similar probe device.

C. Cleaning Coil

To gain access to coil, it may be necessary to cut a window in duct work. After cutting out section of duct work and cleaning coil, cover opening with new, evenly cut piece of sheet metal and fasten in place with sheet metal screws. Coil is easily cleaned when dry. Therefore, check and clean coil before each cooling season. Inspect coil periodically during cooling season. If coil is coated with dirt or lint, clean with a vacuum using soft brush attachment. **BE CAREFUL NOT TO BEND COIL FINS.** If coil is coated with oil or grease, disconnect and remove coil from duct work. Clean coil with mild detergent and water solution. Rinse with clear water.

Figure 4		CFM and Pressure Drop						
Coil Size	CFM Across Coil	Static Pressure Drop Across Coil (Inches Water Column)		Coil Size	CFM Across Coil	Static Pressure Drop Across Coil (Inches Water Column)		
		Dry	Wet			Dry	Wet	
		24 2 tons	400			0.060	0.069	48 4 tons
500	0.081		0.096	700	0.076	0.101		
600	0.104		0.129	800	0.091	0.123		
700	0.129		0.162	900	0.105	0.149		
800	0.155		0.198	1000	0.121	0.175		
900	0.186		0.237	1100	0.138	0.206		
1000	0.217		0.278	1200	0.157	0.215		
30 2½ tons	400		0.044	0.050	1300	0.175	0.231	
	500	0.060	0.071	1400	0.195	0.261		
	600	0.077	0.093	1500	0.217	0.291		
	700	0.097	0.116	1600	0.238	0.325		
	800	0.116	0.144	1700	0.260	0.361		
	900	0.140	0.172	1800	0.284	0.394		
	1000	0.165	0.203	60 5 tons	800	0.051	0.063	
	1100	0.190	0.235		900	0.060	0.076	
1200	0.219	0.269	1000		0.069	0.089		
36 3 tons	400	0.043	0.048		1100	0.079	0.102	
	500	0.058	0.066		1200	0.090	0.118	
	600	0.074	0.086		1300	0.101	0.135	
	700	0.089	0.104		1400	0.113	0.155	
	800	0.107	0.128		1500	0.125	0.175	
	900	0.127	0.154		1600	0.138	0.193	
	1000	0.150	0.182		1700	0.153	0.214	
	1100	0.172	0.212		1800	0.165	0.235	
	1200	0.197	0.245		1900	0.180	0.258	
	1300	0.224	0.280	2000	0.195	0.279		
	1400	0.252	0.317	42 3½ tons	600	0.065	0.076	
	600	0.065	0.076		700	0.079	0.094	
700	0.079	0.094	800		0.095	0.114		
800	0.095	0.114	900		0.113	0.137		
900	0.113	0.137	1000		0.134	0.163		
1000	0.134	0.163	1100		0.154	0.189		
1100	0.154	0.189	1200		0.176	0.215		
1200	0.176	0.215	1300		0.197	0.245		
1300	0.197	0.245	1400		0.220	0.273		
1400	0.220	0.273	1500		0.246	0.303		
1500	0.246	0.303	1600	0.268	0.332			
1600	0.268	0.332						

R-410A QUICK REFERENCE GUIDE

- R-410A refrigerant operates at 50% – 70% higher pressures than R-22. Be sure that servicing equipment and replacement components are designed to operate with R-410A.
- R-410A refrigerant cylinders are rose colored.
- Recovery cylinder service pressure rating must be 400 psig, DOT 4BA400 or DOT BW400.
- R-410A systems should be charged with liquid refrigerant. Use a commercial type metering device in the manifold hose.
- Manifold sets should be 750 psig high-side and 200 psig low-side with 520 psig low-side retard.
- Use hoses with 750 psig service pressure rating.
- Leak detectors should be designed to detect HFC refrigerant.
- R-410A, as with other HFC refrigerants, is only compatible with POE oils.
- POE oils absorb moisture rapidly. Do not expose oil to atmosphere.
- POE oils may cause damage to certain plastics and roofing materials.
- Vacuum pumps will not remove moisture from oil.
- A liquid line filter-drier is required on every unit.
- Do not use liquid line filter-driers with rated working pressures less than 600 psig.
- Do not install a suction line filter-drier in liquid line.
- Wrap all filter-driers and service valves with wet cloth when brazing.
- Do not use with an R-22 TXV.
- If indoor unit is equipped with an R-22 TXV, it must be changed to an R-410A TXV.
- Do not use capillary tube indoor coils.
- Never open system to atmosphere while it is under a vacuum.
- When system must be opened for service, break vacuum with dry nitrogen and replace all filter-driers.
- Do not vent R-410A into the atmosphere.
- Observe all **WARNINGS**, **CAUTIONS**, **NOTES**, and **bold** text.