

CONVERTIBLE SINGLE PACKAGE GAS / ELECTRIC

FEATURES

EFFICIENCY

3 thru 5 tons Cooling, 90,000 thru 150,000 BTUH Heating

SINGLE PACKAGE

- Combination gas heating and electric cooling, self contained for year-round comfort. Systems installed on rooftop or ground level. The unit is shipped in the horizontal position and can easily be converted to downflow.

CONSTRUCTION

- 20 gauge galvanized-painted cabinet. One piece weather resistant top. Access panels for easy service. Side by side supply and return. Heavy gauge base with rails.

CABINET

- Triple-coated steel, consisting of a Polyester top coat, a urethane primer coat preceded by an oxide pretreatment.

COMPRESSOR

- All models are equipped with high efficiency scroll compressor.

SLIDE-OUT BLOWER HOUSING

- Specially designed track enhances evaporator motor and blower serviceability.

IMPROVED INSULATION

- Dual density insulation improves temperature separation.

COPPER TUBE/ALUMINUM FIN COILS

- Enhanced aluminium fins mechanically bonded to copper tubes for improved heat transfer.

METERING DEVICE

- Thermostat Expansion Valve (TXV) controls refrigerant flow, maintaining evaporator superheat for maximum efficiency.

ELECTRICAL AND GAS CONTROLS

- Located behind one exterior panel for easier maintenance.
- Electronic pilot ignition device (HSP).
- Adjustable electronic fan control with optional low speed continuous fan feature responds quickly to circulate heated air and provide maximum comfort.

HIGH / LOW PRESSURE SWITCHES

- Excellent Compressor Protection.

INDUCED DRAFT COMBUSTION SYSTEM

- For smoother combustion and optimal efficiency.

ALUMINIZED TUBULAR HEAT EXCHANGER

- Tubular design delivers efficient heat transfer and air flow: aluminized coating protects against corrosion.

IN-SHOT BURNERS

- Delivers more complete, efficient combustion.

2 INCH FILTERS STANDARD

- Evaporator Coil Protection

EXTERNALLY-MOUNTED GAUGE PORTS

- Allows for more accurate reading of operating conditions while servicing.

INTEGRAL BASE RAILS

- Fork-lift access on three sides. Holes provided for lifting lugs makes rooftop installation easier.

WARRANTY

- 10 years on Heat Exchanger
- 5 years on Compressor
- 1 years on Parts

12 SEER



Rated in accordance with ARI Standard 210.



MODEL NUMBER	ELECTRICAL DATA			Condenser Data									
				Coil			Fan Motor			Fan			
	Volt-PH-Hz	HACR Breaker / Max. Fuse	Ampacity	Total Face Area (Sq. Ft.)	Fins Per In. / Rows	Tube Diameter (In.)	Horsepower	Full Load Amps	Locked Rotor Amps	Size Diameter (In.)	Degree Pitch	RPM (Max.)	CFM (Max.)
PGME36H090	208/230-3-60	30	21.3	11.45	20 / 2	3/8	1/3	1.3	3.57	20.0	25	1120	3000
PGME36H115	208/230-3-60	30	21.3	11.12			1/3	1.3	3.57	20.0	25	1120	3000
PGME36F090	460-3-60	15	10.8	11.45	20 / 2	3/8	1/3	0.7	1.84	20.0	25	1120	3000
PGME36F115	460-3-60	15	20.8	11.12			1/3	0.7	1.84	20.0	25	1120	3000
PGME42H090	208/230-3-60	35	23.6	17.10	20 / 2	3/8	1/2	1.8	6.42	22.0	22	1140	3500
PGME42H115	208/230-3-60	35	23.6	16.41			1/2	1.8	6.42	22.0	22	1140	3500
PGME42F090	460-3-60	15	11.8	17.10	20 / 2	3/8	1/2	0.8	3.40	22.0	22	1140	3500
PGME42F115	460-3-60	15	11.8	16.41			1/2	0.8	3.40	22.0	22	1140	3500
PGME48H090	208/230-3-60	35	23.1	17.10	20 / 2	3/8	1/2	1.8	6.42	22.0	22	1140	3500
PGME48H135	208/230-3-60	35	23.1	16.41			1/2	1.8	6.42	22.0	22	1140	3500
PGME48F090	460-3-60	15	12.3	17.10	20 / 2	3/8	1/2	0.8	3.40	22.0	22	1140	3500
PGME48F135	460-3-60	15	12.4	16.41			1/2	0.8	3.40	22.0	22	1140	3500
PGME60H115	208/230-3-60	45	28.4	17.10	20 / 2	3/8	1/2	1.8	6.42	22.0	22	1140	3500
PGME60H150	208/230-3-60	45	29.4	16.41			1/2	1.8	6.42	22.0	22	1140	3500
PGME60F115	460-3-60	20	14.6	17.10	20 / 2	3/8	1/2	0.8	3.40	22.0	22	1140	3500
PGME60F150	460-3-60	20	15.1	16.41			1/2	0.8	3.40	22.0	22	1140	3500

MODEL NUMBER	Evaporator Coil										Compressor		Factory Refrigerant Charge R-22 Oz.	Ship. Weight (Lbs.)	Sound Rating
	Coil			Blower H.P. / Type / Speeds	Motor		Blower			Run Load Amps	Locked Rotor Amps				
	Total Face Area (Sq. Ft.)	Fins Per In. / Rows	Tube Diameter (In.)		Full Load Amps	Locked Rotor Amps	Type & Size	RPM (Max.)	CFM Rated						
PGME36H090	3.56	14 / 4	3/8	3/4 / PSC / 3	5.6	12.85	DD11-9A	1075	1200	11.5	77	102	429	7.6	
PGME36H115							DD11-9A	1075					439		
PGME36F090	3.56	14 / 4	3/8	3/4 / PSC / 3	5.6	12.85	DD11-9A	1075	1200	5.8	39	102	429	7.6	
PGME36F115							DD11-9A	1075					439		
PGME42H090	8.22	14 / 3	3/8	1/2 / PSC / 4	4.4	8.6	DD10-9	1075	1400	13.9	88	180	559	8.2	
PGME42H115													560		
PGME42F090	8.22	14 / 3	3/8	1/2 / PSC / 4	4.4	8.6	DD10-9	1075	1400	7.0	44	180	559	8.2	
PGME42F115													560		
PGME48H090	8.22	14 / 4	3/8	1/2 / PSC / 4	4.4	8.6	DD10-9	1075	1650	13.5	120	215	603	7.8	
PGME48H135				1.0 / PSC / 3	4.6	7.9	DD11-11	1000					630		
PGME48F090	8.22	14 / 4	3/8	1/2 / PSC / 4	4.4	8.6	DD10-9	1075	1650	7.4	49.5	215	603	7.8	
PGME48F135				1.0 / PSC / 3	4.6	7.9	DD11-11	1000					630		
PGME60H115	8.22	14 / 4	3/8	1.0 / PSC / 4	5.0	8.6	DD11-11	1000	1800	17.3	123	215	626	8.0	
PGME60H150				1.0 / PSC / 4	6.0	15.1		1100					636		
PGME60F115	8.22	14 / 4	3/8	1.0 / PSC / 4	5.0	8.6	DD11-11	1000	1800	9.0	62	215	626	8.0	
PGME60F150				1.0 / PSC / 4	6.0	15.1		1100					636		

PERFORMANCE DATA: HEATING

MODEL NUMBER	Input (MBTUH)		Output (MBTUH)		Efficiency *		Temperature Rise ° F	Gas Piping Size (In.)	Transformer Size Va.
	Standard	Low Fire Kit ¹	Standard	Low Fire Kit ¹	DOE (AFUE)				
					Std.	LFK			
PGME36H090	90	75	70	59	80.2	80.0	35-65	1/2	40
PGME36H115	115	95	90	75	80.0	80.4	45-75	1/2	40
PGME36F090	90	75	70	59	80.2	80.0	35-65	1/2	40
PGME36F115	115	95	90	75	80.0	80.4	45-75	1/2	40
PGME42H090	90	75	71	60	80.8	81.5	30-60	1/2	40
PGME42H115	115	95	90	75	80.1	80.2	35-65	1/2	40
PGME42F090	90	75	71	60	80.8	81.5	30-60	1/2	40
PGME42F115	115	95	90	75	80.1	80.2	35-65	1/2	40
PGME48H090	90	75	71	60	80.8	81.5	30-60	1/2	40
PGME48H135	135	110	106	87	80.4	80.7	35-65	1/2	40
PGME48F090	90	75	71	60	80.8	81.5	30-60	1/2	40
PGME48F135	135	110	106	87	80.4	80.7	35-65	1/2	40
PGME60H115	115	95	91	75	80.8	80.9	30-60	1/2	40
PGME60H150	150	130	119	102	80.8	80.1	35-65	1/2	40
PGME60F115	115	95	91	75	80.8	80.9	30-60	1/2	40
PGME60F150	150	130	119	102	80.8	80.1	35-65	1/2	40

¹ Field conversion kit available for lower fire rate (Natural Gas only).

* As determined by D.O.E. Annual Fuel Utilization Efficiency (A.F.U.E.) Rating Test. Heating capacity valid for elevations up to 2,000 feet above sea level. For elevations above 2,000 feet, rated capacity should be reduced by 4% for each 1,000 feet above sea level.

SPECIFICATIONS SUBJECT TO CHANGE WITHOUT NOTICE

PERFORMANCE DATA: COOLING

MODEL NUMBER	Rated Capacity ¹ BTUH	S / T Ratio	S.E.E.R.	E.E.R. ³	Power Input Watts	Evaporator Rated Airflow (SCFM)	Ext. Static Pressure Drop ² Wet
PGME36H/F090	34,400	.77	12.05	10.10	3405	1200	.20
PGME36H/F115							.30
PGME42H/F090	41,500	.77	12.10	10.35	4008	1400	.34
PGME42H/F115							
PGME48H/F090	48,000	.78	12.10	10.08	4760	1650	.31
PGME48H/F135							
PGME60H/F115	58,500	.73	12.05	9.71	6022	1800	.38
PGME60H/F150							

¹ ARI Rated Capacity @ 230 Volts 80°db/67°wb -95° amb.. For applications at 208 volts deduct 1000 BTUH. ² Includes a .08 drop for a filter ³ For reference only

PERFORMANCE DATA: COOLING

Model Number	Motor Speed	Air Delivery in CFM * External Static Pressure (In. W.C.)					
		.20	.30	.40	.50	.60	.70
PGME36H/F090	HI	1435	1375	1310	1245	1175	1105
	MED	1270	1220	1165	1100	1045	990
	LO	1110	1080	1045	1005	955	905
PGME36H/F115	HI	1645	1580	1515	1450	1385	1315
	MED HI	1490	1440	1385	1330	1270	1210
	MED LO	1295	1270	1235	1195	1145	1095
	LO	1070	1055	1040	1020	990	955
PGME42H/F090 42H/F115 48H/F090	HI	1860	1795	1725	1650	1570	1485
	MED HI	1735	1680	1620	1560	1485	1405
	MED LO	1540	1505	1465	1415	1350	1280
	LO	1460	1430	1395	1345	1290	1225
PGME48H/F135	HI	2185	2125	2065	2010	1950	1875
	MED	1805	1775	1735	1690	1635	1580
	LO	1685	1660	1625	1585	1540	1485
PGME60H/F115	HI	2250	2190	2125	2060	1990	1915
	MED HI	2090	2045	1995	1935	1875	1805
	MED LO	1650	1630	1600	1565	1525	1475
	LO	1315	1300	1280	1255	1225	1185
PGME60H/F150	HI	2400	2325	2250	2170	2085	2000
	MED HI	2335	2270	2200	2125	2050	1965
	MED LO	2205	2145	2080	2015	1940	1865
	LO	2095	2040	1985	1920	1855	1780

Air delivery against shown external static pressures taken with 230V to unit and dry coil. For wet coil subtract approximately 25 CFM. Add .08 static for internal filters.

* Dry coil, no filter.

ACCESSORIES: ROOF CURBS

These curbs are designed specifically for use with our combination gas/electric units. They are constructed of heavy gauge steel and designed for water tight installation.

Description	Mainline Model Number	Used on
8"	AXB020CLA	3 Ton
	AXB030CLA	3-1/2 to 5 Ton
14"	AXB020CMA	3 Ton
	AXB030CMA	3-1/2 to 5 Ton
24"	AXB020CHA	3 Ton
	AXB030CHA	3-1/2 to 5 Ton

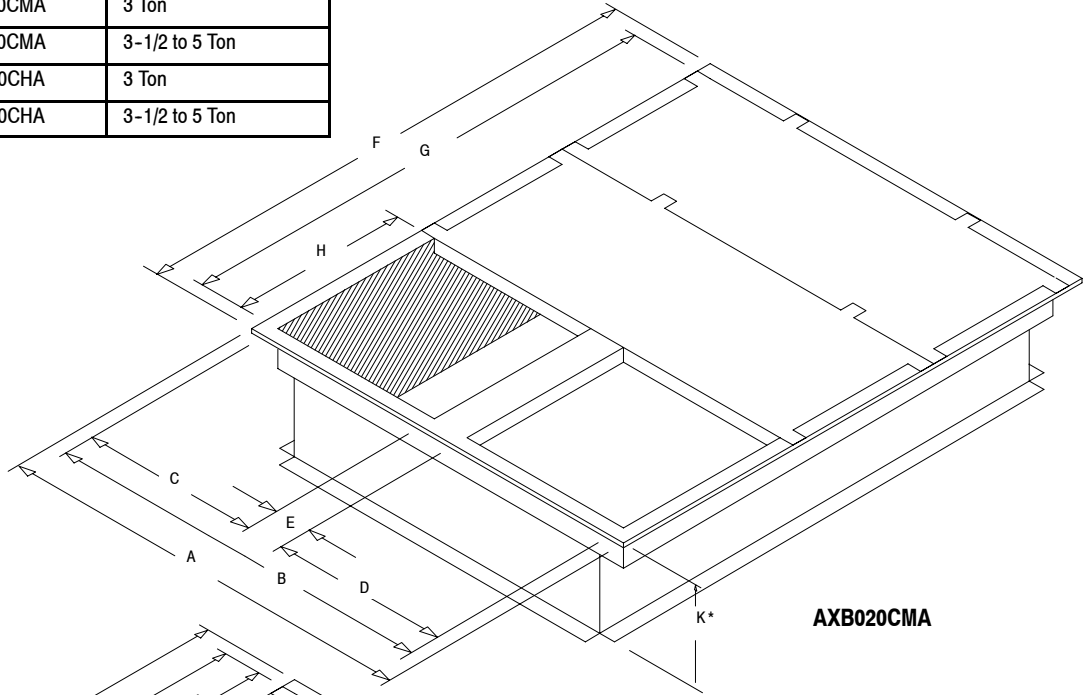

AXB020CMA

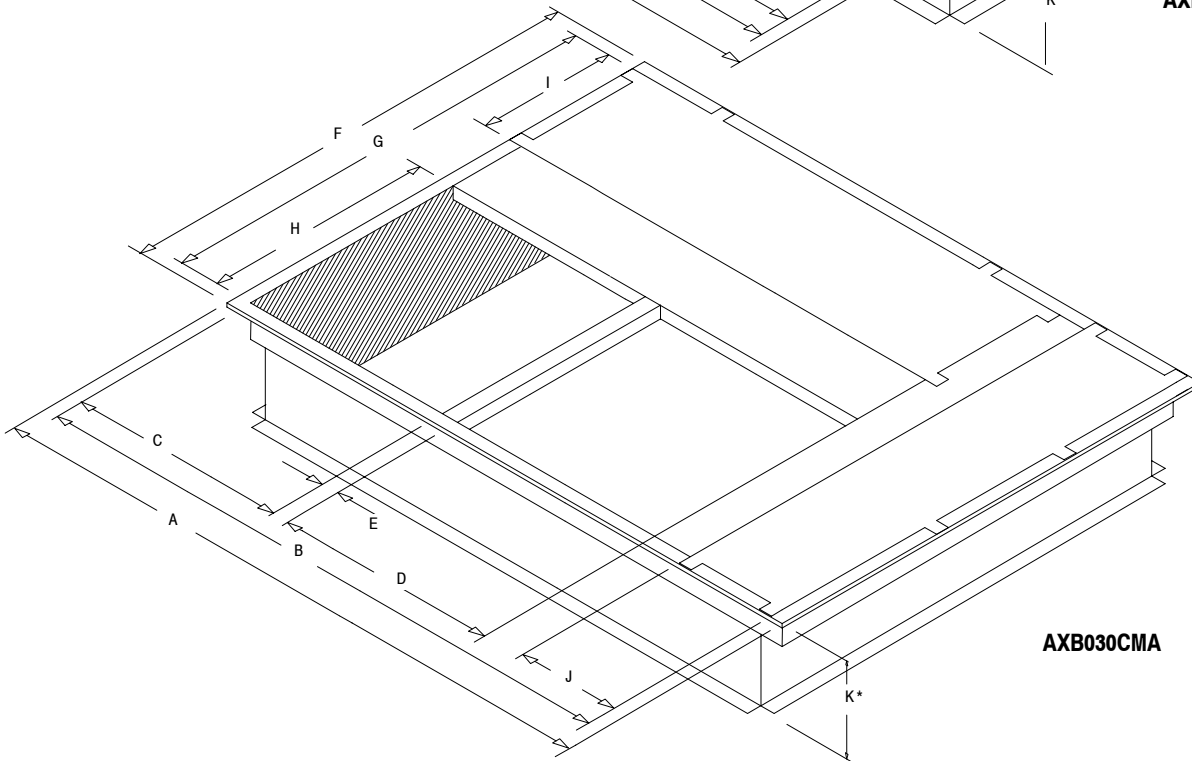

AXB030CMA

ROOF CURB DIMENSIONS (INCHES)

Model No.	A	B	C	D	E	F	G	H	I	J	K(CLA)	K(CMA)	K(CHA)
AXB020	42-3/4	39-3/4	18	18	3-3/4	42-3/4	39-3/4	18	-	-	8	14	24
AXB030	67-3/4	64-3/4	23	23	2-1/2	42-3/4	39-3/4	23	12	12	8	14	24

ECONOMIZERS/DOWNFLOW

ALL DIMENSIONS IN INCHES

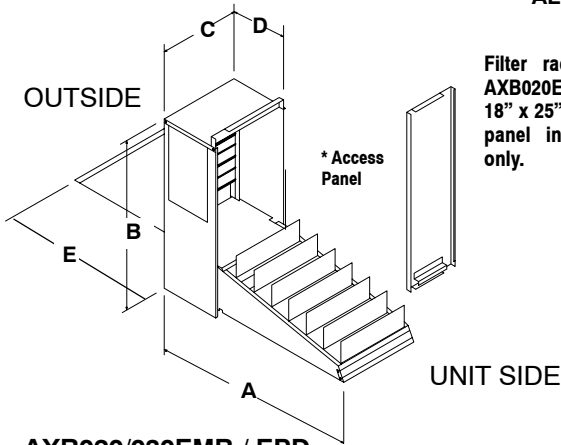

Filter racks are included with AXB020E**. Economizers require 18" x 25" x 1" or 2" filters. Access panel included with AXB030E** only.

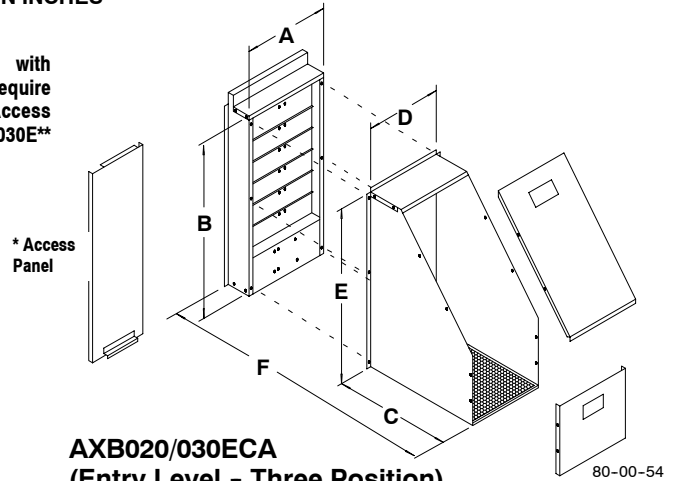

**AXB020/030EMB / EPD
(Modulating or Three Position)**

Economizer Model No.	A	B	C	D	E
AXB020EMC/PD	29	27-1/2	12-3/4	10-7/8	22
AXB030EMC/PD	35	31	14-3/4	10-7/8	22

**AXB020/030ECA
(Entry Level - Three Position)**

Economizer Model No.	A	B	C	D	E	G
AXB020ECA	12-3/4	27-1/2	20-1/4	11	28-1/2	24
AXB030ECA	14-3/4	31	20-1/4	13	30	24

Description	Model Number	Used on
Fully Modulating (1)	AXB020EMC	3 Ton
Three Position (2)	AXB020EPD	
Entry Level Three Position (3)	AXB020ECA	

Description	Model Number (4)	Used on
Fully Modulating (1)	AXB030EMC	3-1/2 to 5 Ton
Three Position (2)	AXB030EPD	
Entry Level Three Position (3)	AXB030ECA	

NOTES:

- (1) - Ambient/Enthalpy Control; Includes Return Air Damper & Relief Damper.
- (3) - Ambient Control Only; No Return Air Damper; No Relief Damper.

- (2) - Ambient Control Only; Includes Return Air Damper & Relief Damper.
- (4) - On AXB030, Filters not supplied. Filter retainers and filters can be ordered thru Service Parts, retainer part number 1054517. Filters (20x30x2) part number 1054503.

All Economizers Feature Enthalpy and/or ambient temperature control providing outdoor air ventilation and "free cooling" when outdoor conditions are favorable.

Return Air and Pressure Relief dampers for proper air balance, on most models.

Interconnecting wiring furnished.

Center controlled dual action dampers with gaskets to provide proper seal.

ECONOMIZERS/HORIZONTAL

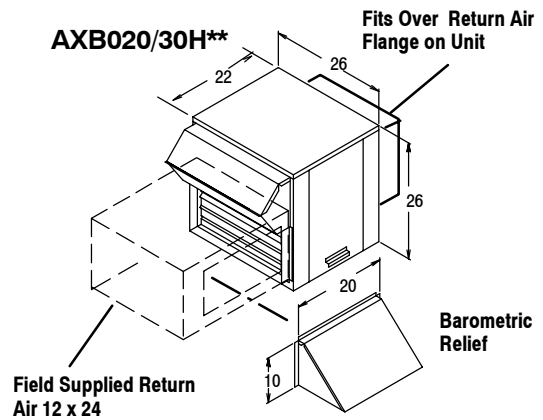

Description	Model Number	Used on
Fully Modulating (1)	AXB020HEC	3 Ton
Three Position (2)	AXB020HPD	

Description	Model Number	Used on
Fully Modulating (1)	AXB030HEC	3-1/2 to 5 Ton
Three Position (2)	AXB030HPD	

NOTES:

- (1) - Ambient/Enthalpy Control; Includes Return Air Damper & Relief Damper.
- (2) - Ambient Control Only; Includes Return Air Damper & Relief Damper.

ACCESORIES (CONT...)

OUTDOOR AIR DAMPERS

Description	Model Number	Used on
Manual - 25%	AXB020FAC	3 TON
	AXB030FAC	3-1/2 to 5 TON
Motorized - 25%	AXB020FMC	3 TON
	AXB030FMC	3-1/2 to 5 TON

FILTER RACK - must use with 3 ton, for Horizontal Duct Applications Oly.

Description	Model Number	Used on
* Horizontal	AXB020FHC	3 TON

* Requires 1 field supplied 18 x 25" filter.

COIL PROTECTION

Description	Service Parts Number *	Used on
Coil Guard	1149485	3 TON
	1149486	3-1/2 to 5 TON
Hail Guard	1068133	3 TON
	1068134	3-1/2 to 5 TON

* Available through Service Parts only.

LOW FIRE KITS (NATURAL GAS ONLY)

Description Standard Heat Input	Service Parts Number *	New Low Fire Heat Input
90,000 BTUH Kit	1148135	75,000 BTUH
115,000 BTUH Kit	1148136	95,000 BTUH
135,000 BTUH Kit	1148137	110,000 BTUH
150,000 BTUH Kit	1148138	130,000 BTUH

* Available through Service Parts only.

FOSSIL FUEL CONVERSION

Description	Service Parts Number	Used On Heat Input
Natural to LP Gas *	1149744	90 MBTUH
	1149745	115 MBTUH
	1149746	135 MBTUH
	1149747	150 MBTUH
Natural to LP Gas **	1084495	90 MBTUH
	1084496	115 MBTUH
	1084497	135 MBTUH
	1084498	150 MBTUH
LP to Natural Gas	1148142	90, 115, 135, & 150 MBTUH

* These kits convert all gas package units manufactured up to date code L9741.

** These kits will convert all gas package units manufactured up to date code L9741 and remove the turbulators in these units. These kits will also convert all gas packages manufactured after L9742 till current date.

CONCENTRIC DUCT KITS

Description	Mainline Model Number	Used on
Transition	AXB020CTA	3 TON
	AXB030CTA	3-1/2 to 5 TON
Grille, Flush Mount *	AXB020CFA	3 TON
	AXB030CFA	3-1/2 to 5 TON
Grille, Step Down *	AXB020CSA	3 TON
	AXB030CFA	3-1/2 to 5 TON

* Includes grille and diffuser / transtion box.

LOW AMBIENT CONTROLS

Description	Model Number *	Used on
To 0° F	1148232	3 TON

* Available through Service Parts only.

INTERNAL FILTERS AND ACCESSORIES

Description	Model Number *	Used on
Filter Retainer (2 Req.)	1054517	3-1/2 to 5 TON
Filter (2 Req.)	1054503	3-1/2 to 5 TON
Handle, Filter Access Panel	1068209	3-1/2 to 5 TON

* Available through Service Parts only.

UNIT DIMENSIONS

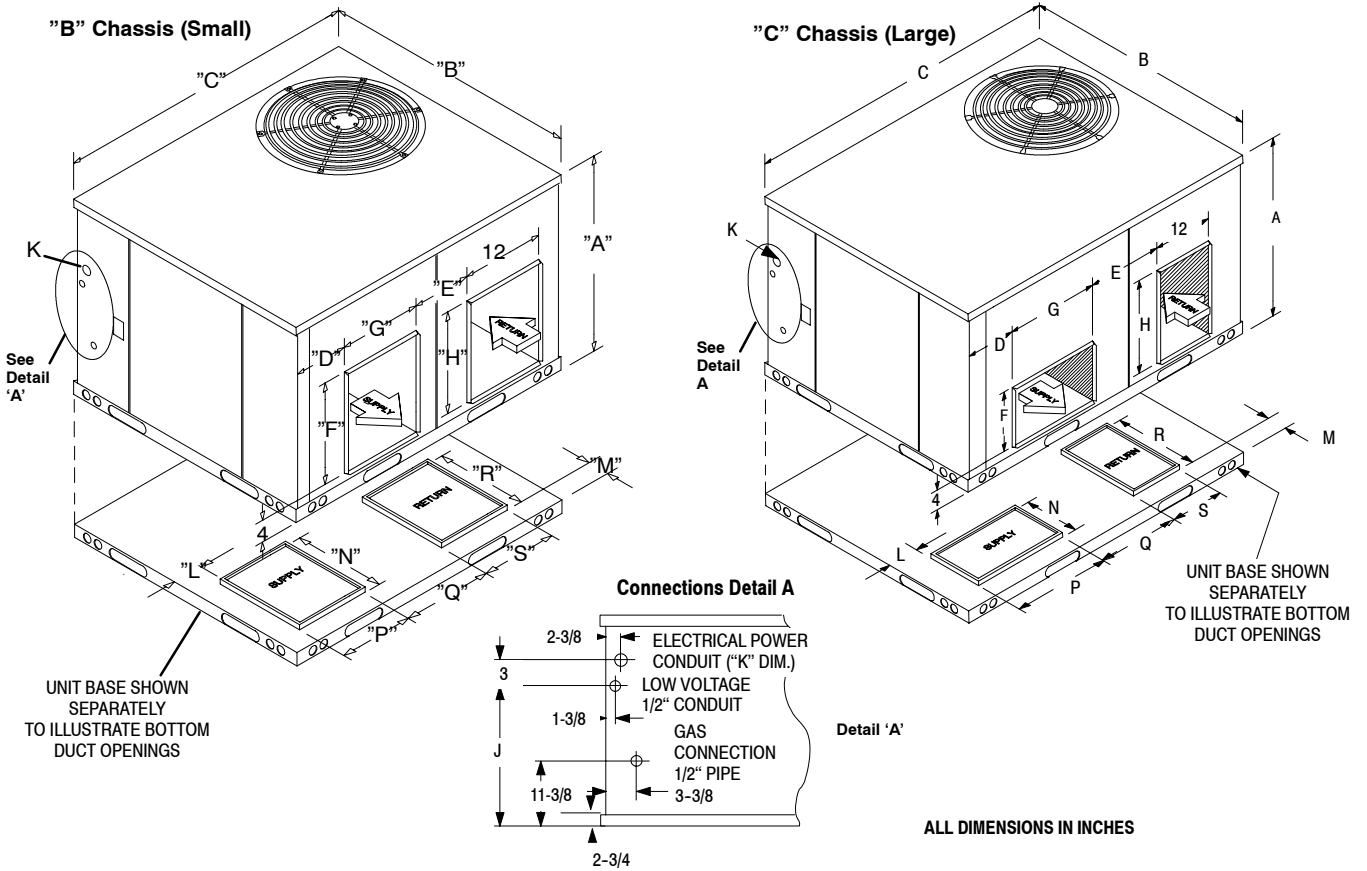

Model No.	A	B	C	D	E	F	G	H	J	K	L	M	N**	P**	Q	R	S	Inside Base Rail
3 Ton	32-1/2	47-3/8	47-3/8	3-1/8	11-1/8	12	14-1/4	14-1/4	21-1/2	3/4 - 1	4-1/4	4-3/8	14-1/2	12-1/4	12-1/8	14-1/4	12-1/4	43-1/8 x 43-1/8
3-1/2 to 5 Ton	36	47-3/8	73	4-5/8	15	12	18-3/4	18-3/4	25-1/2	1 - 1-1/4	4-1/4	5-1/4	12-1/4	19	15	19	12-1/4	68-3/4 x 43-1/8

* NOTE: The base rail width is 2-1/8 inches, all around base of unit.

MODEL NUMBER IDENTIFICATION GUIDE

MODEL NUMBER	P	G	M	E	24	G	060
PRODUCT FAMILY P = Single Package							
FUEL (Heating) G = Gas							
MULTI-POSITION							
DESIGN SERIES E = Ultra-High Efficiency							
							GAS HEAT INPUT 040 = 40,000 115 = 115,000 060 = 60,000 135 = 135,000 090 = 90,000 150 = 150,000
							ELECTRICAL CHARACTERISTICS G = 208 / 230-3-60
							COOLING CAPACITY (NOMINAL BTUH) 18 = 1-1/2 Ton 42 = 3-1/2 Ton 24 = 2 Ton 47 = 4 Ton 30 = 2-1/2 Ton 60 = 5 Ton 36 = 3 Ton

GUIDE SPECIFICATIONS

CABINET

The cabinet is made of G-90 galvanized steel, phosphate coated with a tough acrylic finish coat for long lasting weatherproof construction. The base rails are 18 gauge steel with fork lift slots and holes provided for lifting shackles. The unit is designed with convertible airflow for either horizontal or downflow applications with conversion accomplished by relocating two panels. Indoor blower compartment interior cabinet surfaces are insulated with a minimum 3/4" thick, flexible glass insulation, coated on the air side. Aluminum foil faced glass fiber insulation is used in the furnace compartment.

COOLING SECTION

The unit is factory charged and operationally ready upon delivery. The unit refrigerant circuit has a high efficiency fully hermetic compressor with internal overload protection, and copper tube / aluminum fin evaporator and condenser coils. The unit is designed for cooling operation to 40° F and will be capable of being wired for field installed economizer type accessories.

COILS

The evaporator and condenser coils are fabricated with aluminum fins mechanically bonded to copper tubing. Both coils are pressure tested prior to

assembly into the unit and electronically leak tested after assembly into the unit.

CONDENSER FAN

The unit has a single direct-drive propeller-fan / motor assembly. The assembly is mounted directly to a vertical-discharge grille that is easily removed for service. Motors are 1100 RPM with sleeve or ball bearings and internal overload protection.

EVAPORATOR BLOWER

All units have a direct-drive evaporator blower motor as a standard. The direct-drive evaporator blower motor has sleeve bearings and internal overload protection.

HEATING SECTION

The gas-fired heating section features an induced draft blower for combustion air. The unit has an aluminized steel tubular heat exchanger located on the discharge air side of the blower. The system uses in-shot burners ignited by a hot surface pilot ignition system, protected by both a high heat limit switch and flame roll-out switch. The induced draft blower motor is interlocked with a proven air pressure safety device.

AGENCY CERTIFICATIONS



INSTALLATION CLEARANCES

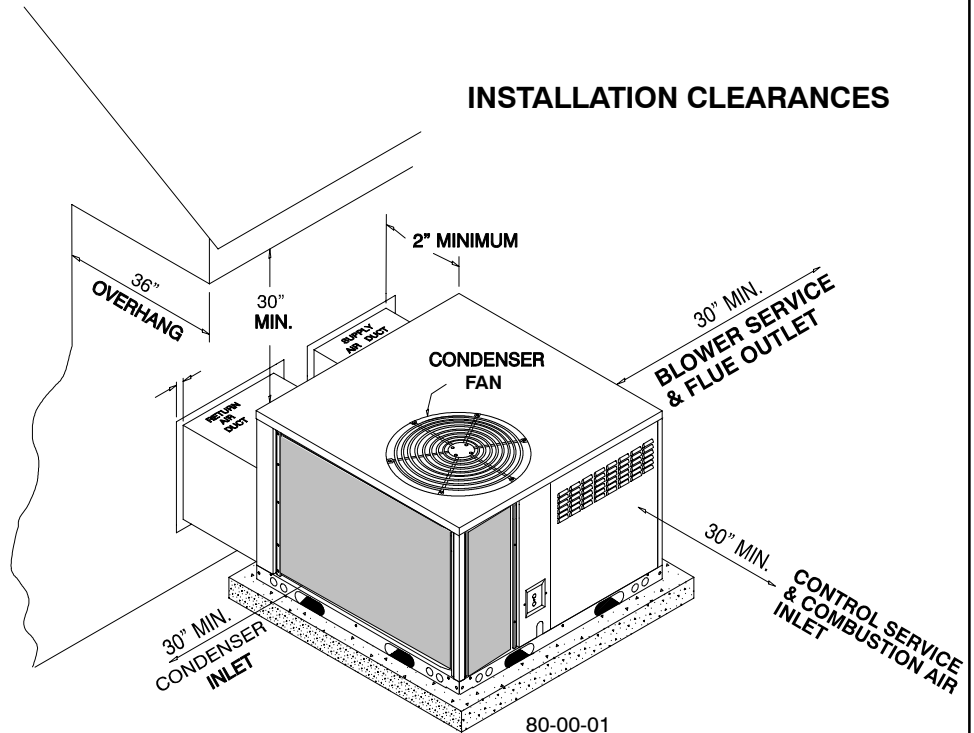

RIGGING DETAILS

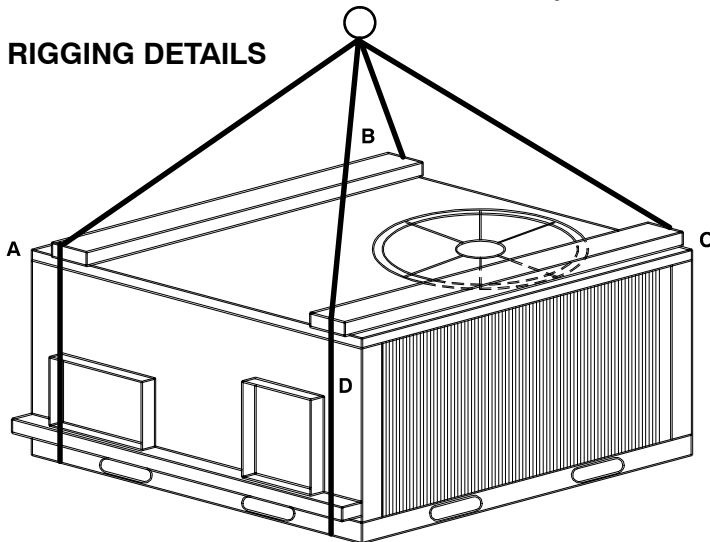

CORNER WEIGHTS (LBS)

MODEL	A	B	C	D	OPERATING WEIGHT
PGME36H/F090	89	112	127	101	429
PGME36H/F115	92	114	130	103	439
PGME42H/F090	124	155	155	125	559
PGME42H/F115	125	155	155	125	560
PGME48H/F090	135	166	166	136	603
PGME48H/F135	141	174	174	141	630
PGME60H/F115	140	173	173	140	626
PGME60H/F150	142	176	176	142	636

SPECIFICATION SUBJECT TO CHANGE WITHOUT NOTICE