

Installation Instructions For Propane Gas Conversion

Kit Part No. NPLPCONV013A00, Standard Altitude Only 0-2,000 ft.

Models WPG3**4, PGD3, PGS3, PDD3, PDS3, PGD4, PGS4, PGN4, PGD5, PGS5, PGN5

2 to 5 Ton Units - 40,000 to 130,000 Btu/hr

This kit is designed for conversion from Natural Gas to Propane Gas

NOTE: Read the entire instruction manual before starting the installation.

SAFETY CONSIDERATIONS

Installation and servicing of this equipment can be hazardous due to mechanical and electrical components. Only trained and qualified personnel should install, repair, or service this equipment.

Untrained personnel can perform basic maintenance functions such as cleaning and replacing air filters. All other operations must be performed by trained service personnel. When working on this equipment, observe precautions in the literature, on tags, and on labels attached to or shipped with the unit and other safety precautions that may apply.

Follow all safety codes. Installation must be in compliance with local and national building codes. Wear safety glasses, protective clothing, and work gloves. Have fire extinguisher available. Read these instructions thoroughly and follow all warnings or cautions included in literature and attached to the unit.

Recognize safety information. This is the safety-alert symbol . When you see this symbol in instruction manuals be alert to the potential for personal injury.

Understand the signal words DANGER, WARNING, or CAUTION. These words are used with the safety-alert symbol. DANGER identifies the most serious hazards, those that will result in severe personal injury or death. WARNING signifies a hazard that could result in personal injury or death. CAUTION is used to identify unsafe practices that may result in minor personal injury or product and property damage. NOTE is used to highlight suggestions that will result in enhanced installation, reliability, or operation.

Follow all safety codes. Wear safety glasses and work gloves. Have a fire extinguisher available.

WARNING

PERSONAL INJURY, PROPERTY DAMAGE HAZARD

Failure to follow this warning could result in personal injury, death or property damage.

This conversion kit shall be installed by a qualified service agency in accordance with the manufacturer's instructions and all applicable codes and requirements of the authority having jurisdiction and in Canada, in accordance with the CAN/CGA (Canadian Gas Association) B149.2 Installation Code. If the information in these instructions is not followed exactly, a fire, explosion or production of carbon monoxide may result causing personal injury, loss of life, and/or property damage. The qualified service agency is responsible for the proper installation of this kit. The installation is not proper and complete until the operation of the converted furnace is checked as specified in the manufacturer's instructions supplied in the kit.

AVERTISSEMENT

LE FEU, L'EXPLOSION, CHOC ELECTRIQUE, ET MONOXYDE DE CARBONE EMPOISONNER

Cette trousse de conversion doit être installée par un service d'entretien qualifié, selon les instructions du fabricant et selon toutes les exigences et tous les codes pertinents de l'autorité compétente. Assurez-vous de bien suivre les instructions dans cette notice pour réduire au minimum le risque d'incendie, d'explosion ou la production de monoxyde de carbone pouvant causer des dommages matériels, de blessure ou la mort. Le service d'entretien qualifié est responsable de l'installation de cette trousse. L'installation n'est pas adéquate ni complète tant que le bon fonctionnement de l'appareil converti n'a pas été vérifié selon les instructions du fabricant fournies avec la trousse.

CAUTION

UNIT OPERATION HAZARD

Failure to follow this caution may result in damage to unit components.

Before converting a unit to propane gas, remove the burner assembly and inspect the heat exchanger tubes. If there are V-shaped NOx baffles installed in the firing tubes, (see Fig. 1.) THEY MUST BE REMOVED PRIOR TO CONVERTING THIS UNIT TO PROPANE. Discard the baffles after removal.

Figure 1

Removing NOx Baffles

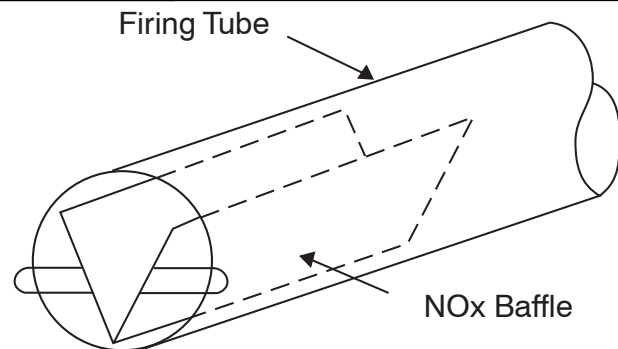

WARNING

EXPLOSION, FIRE, UNIT DAMAGE HAZARD

Failure to follow this warning could result in personal injury or death, and/or unit damage.

This unit is designed to operate at 10 in. wc (± 0.3 in. wc) of manifold pressure with propane gas. Do not exceed this pressure.

Table 1 – Single Stage Kit Contents

ITEM	Part Number	QUANTITY
Installation Instructions	46206210100	1
Propane Gas Orifice #49*	1177088	3
Propane Gas Orifice #51*	1177087	3
Propane Gas Orifice #53*	1177086	3
Propane Gas Orifice #55*	1177085	3
Regulator Spring (92-0659)	EF39ZW023	1
Pressure Switch	HK02LB008	1
90° Elbow, 1/8 in. NPT	CA05RA001	2
Nipple, 1/8 in. NPT x 2 in. (51 mm)	CA01CA010	1
Close Pipe Nipple, 1/8 in. NPT x 3/4 in.	CA01CA001	2
Wire Harness	1177091	1
Propane Conversion Label (Rating Plate)	50CY502305	1
Propane Conversion Label (Installer Responsibility)	50CY502306	1
Propane Conversion Warning Label (Gas Valve)	1177092	1

*Refer to Table 2 to determine the correct orifice to use.

SINGLE STAGE INTRODUCTION

These instructions cover the installation of a propane gas conversion kit on models WPG3**4, PGD3, PGS3, PDD3, PDS3, PGD4, PGS4, PGN4, PGD5, PGS5, PGN5 that are equipped with a White Rodgers single-stage automatic gas valve regulator.

DESCRIPTION AND USAGE

This single-stage kit is applicable to units with heating inputs from 40,000 to 130,000 Btu/hr installed at standard altitudes from 0 ft to 2000 ft. (610 m). They cannot be used for high altitude installation. High altitude conversion (2001–6000 ft) (610–1829 m) must use kit NPLPCONV014A00.

SINGLE STAGE KIT INSTALLATION

⚠ WARNING

FIRE, EXPLOSION, ELECTRICAL HAZARD

Failure to follow this warning could result in personal injury, death or property damage.

Gas supply **MUST** be shut off before disconnecting electrical power and proceeding with conversion.

⚠ WARNING

ELECTRICAL SHOCK HAZARD

Failure to follow this warning could result in personal injury or death.

Before installing or servicing system, always turn off main power to system. There may be more than one disconnect switch. Tag disconnect switch with suitable warning label.

1. Turn off gas supply first, then power to unit.
2. Remove the control access panel from unit.
3. Disconnect the gas pipe from the gas valve.
4. Remove the screw attaching the gas manifold to the basepan, and partially slide out the entire burner rack assembly from unit. Save screw. The fan partition mounting bracket may be removed for easier access to the burner assembly. The bracket may be removed by removing 2 screws (located on the left side of the control compartment on the fan partition panel) and sliding the bracket forward, bottom first. See Fig. 9.
5. Disconnect the gray and brown wires from the gas valve, and remove blue wires from the rollout switch.

NOTE: To locate rollout switch, see Fig. 7.

6. Disconnect orange sparker cable from the sparker.
7. Disconnect yellow flame sensor wire from the flame sensor.

8. Remove the screw securing the brown wire from the burner assembly. Save screw.
9. Completely slide out the entire burner rack assembly from unit. Save screw.
10. Inspect the inlet of the heat exchanger tubes for presence of V-shaped NOx baffles. See Fig. 1. If baffles are present they must be removed prior to converting unit for propane gas. Using needle-nose pliers, remove NOx baffles, squeeze sides of the baffle, if necessary, to remove from the heat exchanger tubes.

IMPORTANT: If it is expected that this unit will be converted back to natural gas at a later time, these baffles should be retained for reuse. Otherwise the baffles may be discarded.

11. Using a 5/16 in. nut driver, remove the four screws securing the manifold/gas valve assembly to the burner assembly. Save these screws.
12. Remove the natural gas orifices from the manifold using a 9/16 in. wrench and install the correct propane orifices in the manifold. See Table 2 to select correct orifice size based on rated input. See Fig. 3 and 6 for orifice installation.
13. Replace the manifold/gas valve assembly into the burner assembly using the four screws saved from Step 11.
14. Remove the plug on the inlet end of the gas valve using a 3/16 in. hex wrench. See Fig. 2.
15. Install the 1/8 in. NPT x 3/4 in. (19 mm) close pipe nipple where the plug was removed. See Fig. 8. Use pipe thread dope or tape (field--supplied, must be certified for use with propane gas) for all joints, making sure not to get any excess in the pipe or valve. Next, install a 1/8 in. elbow, a 1/8 in. NPT x 3/4 in. (19 mm) close pipe nipple, 1/8 in. elbow, 1/8 in. x NPT 2 in. (51 mm) nipple, and a low gas pressure switch as shown in Fig. 8.
16. Remove regulator cover screw from the gas regulator. See Fig. 2. Save regulator cover screw.
17. Using a screwdriver, remove the plastic regulator adjust screw from the gas regulator. See Fig. 2. Save plastic regulator adjust screw.
18. Remove regulator spring (silver) from the gas regulator. See Fig. 2. Discard regulator spring.
19. Install propane gas regulator spring (white) shipped with this kit. See Fig. 2.
20. Install plastic adjust screw into the gas regulator, turn clockwise 13.5 turns. See Fig. 2.
21. Verify igniter, ignitor, flame sensor, orifice/main burner relationship prior to completing conversion. See Fig. 3. Partially slide burner rack assembly into unit.
22. Disconnect the orange wire from the combustion air pressure switch and connect it to the orange wire on the low gas pressure switch (LGPS) equipped with a 1/4 in. male

quick-connect terminal. The low gas pressure switch should have one unconnected orange wire remaining. Connect this wire to the vacant terminal on the combustion air pressure switch. See Fig. 11.

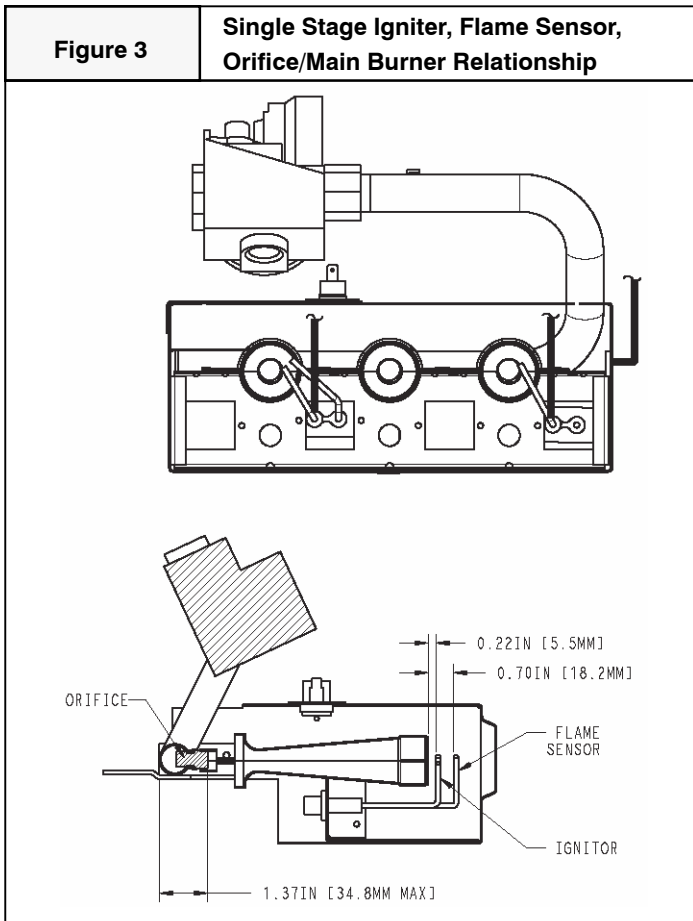
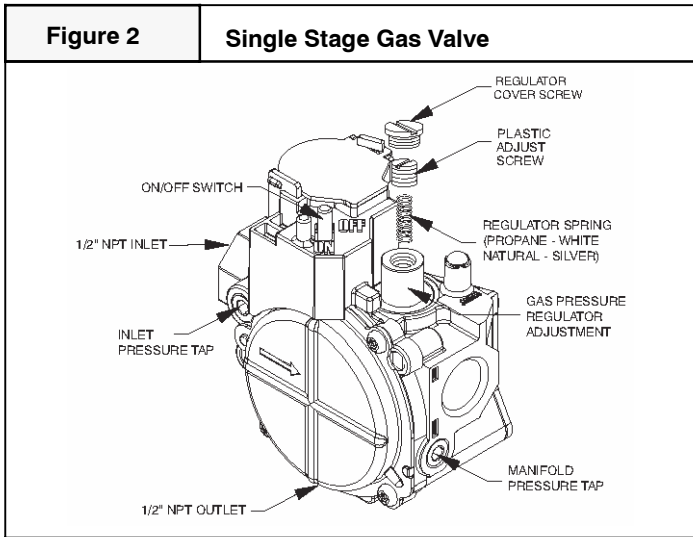

23. Reconnect the blue wires removed in item 5 to the rollout switch and reinstall the rollout switch.
24. Reconnect orange sparker cable to sparker and reconnect the yellow flame sensor wire to the flame sensor.
25. Reconnect the gray and brown wires removed in item 5 to the gas valve.
26. Reconnect the brown wire from the burner assembly to the sheet metal partition.

27. Slide burner rack assembly into base pan. Align burner rack with screws on sheet metal partition and slide assembly back tight to the partition. Replace the screw attaching the burner rack to the base pan removed in step 4. If the fan partition mounting bracket was removed, slide bracket back into place and fasten with 2 screws. See fig. 9.
28. Remove the 1/8 in. pipe plug on the gas manifold and connect a pressure manometer. See Fig. 4.
29. Reconnect electrical power and gas supply to the unit. For propane applications, the gas pressure must not be less than 11.0 IN. W.C. or greater than 13 IN. W.C. at the unit connection. A 1/8-in. NPT plugged tapping, accessible for test gauge connection, must be installed immediately upstream of the gas supply connection to the gas valve and downstream of manual equipment shutoff valve.

The newly installed low gas pressure switch is a safety device used to guard against adverse burner operating characteristics that can result from low gas supply pressure. Switch opens at not less than 6.5 IN. W.C. and closes at not greater than 10.2 IN. W.C.

This switch also prevents operation when the propane tank level is low which can result in gas with a high concentration of impurities, additives, and residues that have settled to the bottom of the tank. Operation under these conditions can cause harm to the heat exchanger system.

This normally open switch closes when gas is supplied to gas valve under normal operating pressure. The closed switch completes control circuit. Should an interruption or reduction in gas supply occur, the gas pressure at switch drops below low gas pressure switch setting, and switch opens. Any interruption in control circuit (in which low gas pressure switch is wired) quickly closes gas valve and stops gas flow to burners.

⚠ WARNING

FIRE AND EXPLOSION HAZARD

Failure to follow this warning could result in personal injury and/or death, and/or property damage.

NEVER use matches, candles, flame, or other sources of ignition to check for gas leakage. Use a soap-and-water solution to check for leaks.

IMPORTANT: Restart unit and leak check all gas connections including the main service connection, gas valve, gas spuds, and manifold pipe plug.

30. Fire unit and verify proper ignition and proper sequence of operation (Table 3). See Table 2 for proper manifold pressure setting for your unit. Adjust the gas valve setting by turning the plastic adjustment screws clockwise to increase pressure and counter-clockwise to decrease pressure. Refer to Table 4 for required rated heating input rates. Replace regulator cover screws when finished. See Fig. 2.
31. With control access panel removed, observe unit heating operation. Watch burner flames to see if they are blue in appearance, and that the flames are approximately the same for each burner. See Fig. 5.
32. Turn off unit, remove pressure manometer and replace the 1/8 in. pipe fitting on the gas manifold. See Fig. 4.
33. Attach warning label (P/N 1177092) to visible side of gas valve.
34. Attach conversion label (P/N 50CY502305) above unit rating plate on exterior of unit.
35. Attach completed conversion responsibility label (see Fig. 10, P/N 50CY502306) inside control access panel.

36. After all leaks are eliminated, replace control access panel.

IMPORTANT: Restart unit and leak check all gas connections including the main service connection, gas valve, gas spuds, and manifold pipe plug.

 <b style="font-size: 24pt; margin-left: 10px;">WARNING
<p>FIRE AND EXPLOSION HAZARD</p> <p>Failure to follow this warning could result in personal injury and/or death, and/or property damage.</p> <p>NEVER use matches, candles, flame, or other sources of ignition to check for gas leakage. Use a soap-and-water solution to check for leaks.</p>

Table 2 – Propane Gas Orifice Sizes

UNIT SERIES	PROPANE NOMINAL HEATING INPUT (BTU/hr)		ALTITUDE OF INSTALLATION ABOVE SEA LEVEL, USA*				
			0 to 2000 ft. (0 to 610 m)	2001 to 3000 ft. (611 to 914 m)	3001 to 4000 ft. (915 to 1219 m)	4001 to 5000 ft. (1220 to 1524 m)	5001 to 6000 ft. (1525 to 1829 m)
WPG3**4, PGD3, PGS3, PDD3, PDS3, PGD4, PGS4, PGN4, PGD5, PGS5, PGN5	40,000	Orifice No. Manifold Press. (in. wc.)	55 10.0	56 11.0	56 11.0	56 11.0	56 10.7
	60,000 90,000	Orifice No. Manifold Press. (in. wc.)	53 10.0	54 11.0	54 11.0	54 11.0	54 11.0
	115,000	Orifice No. Manifold Press. (in. wc.)	51 10.0	52 11.0	52 10.6	53 11.0	53 11.0
	130,000	Orifice No. Manifold Press. (in. wc.)	49 10.0	52 11.0	52 11.0	52 11.0	52 11.0

* For Canadian installations, from 2000 ft. to 4500 ft. (610m to 1372m) use USA column 2001 ft. to 3000 ft. (611m to 914m).

Table 3 – Sequence of Operations

<p>Trial-for-Ignition Sequence: The ignition sequence is to immediately energize the inducer motor on a call for heat. Within approximately 5 sec of the call for heat, the gas valve will open and the igniter will spark. Seven sec will be allowed to prove flame sense on the far burner.</p>
<p>Flame-Proving: Once flame is proven, the control will wait an additional 45 sec to energize the indoor blower motor. On removal of the call for heat, the gas valve will immediately shut down, the inducer motor will run for an additional 5 sec, and the indoor blower will run for an additional 45 sec (minimum).</p>

Figure 4

Burner Assembly

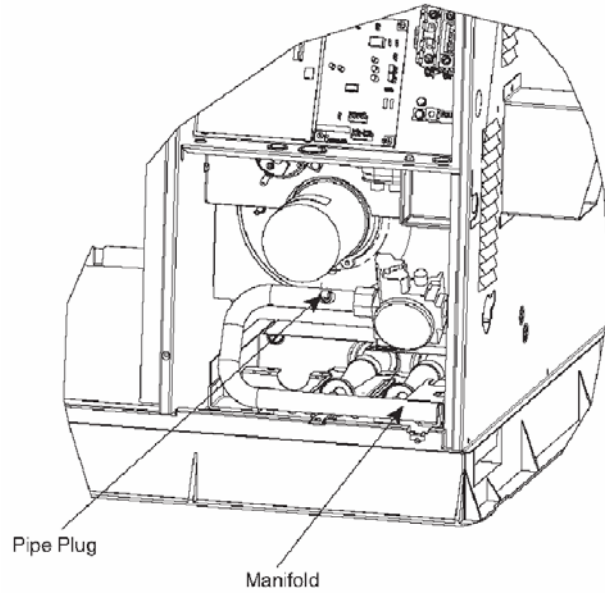

Figure 5

Monoport Burner

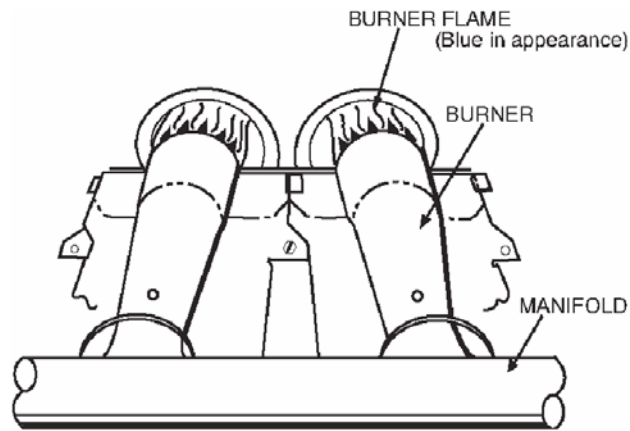

Figure 6

Orifice Installation

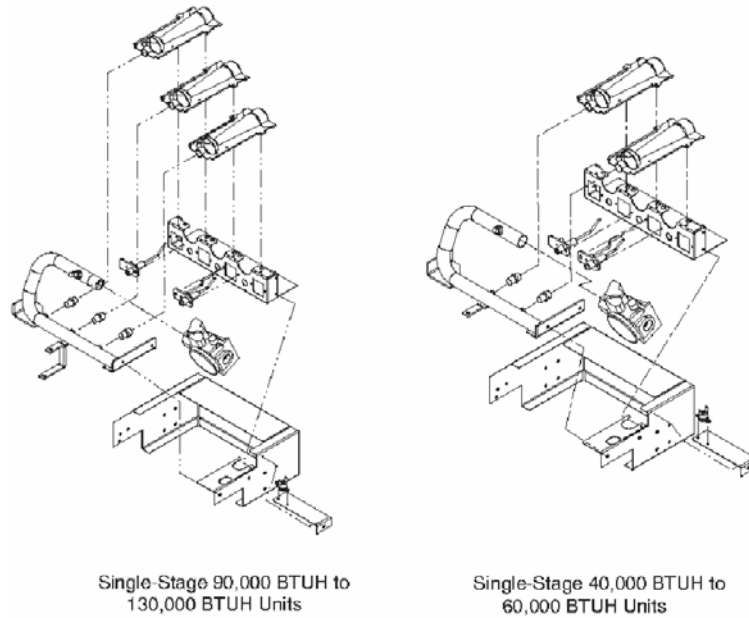

Figure 7

Burner Bracket

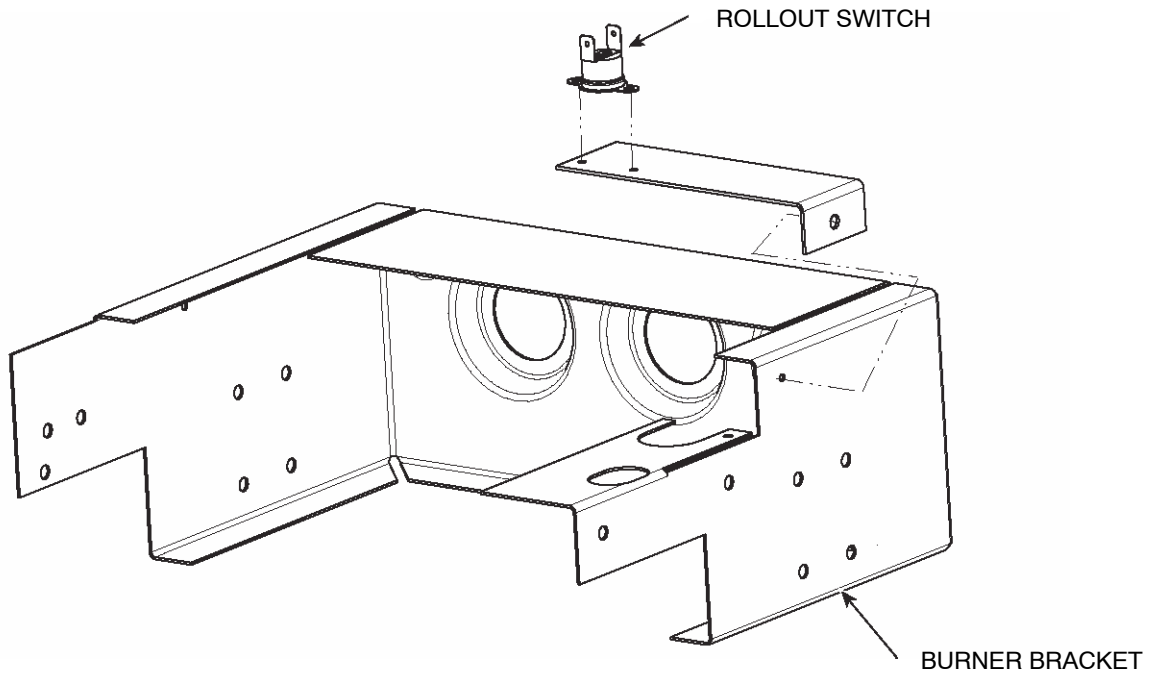

Figure 8

Installing Elbows, Nipples, and Pressure Switch

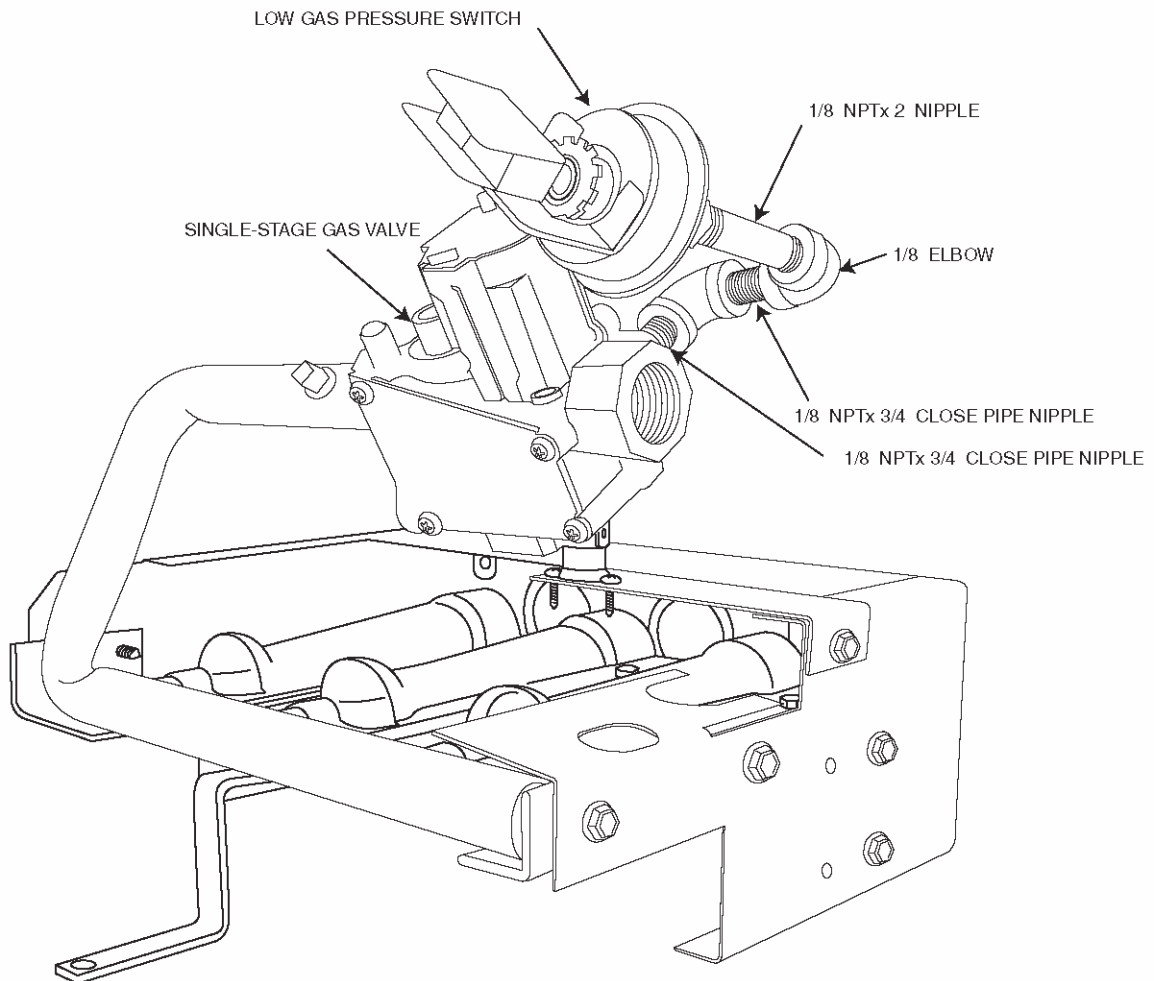

Figure 9

Fan Partition Bracket Removal

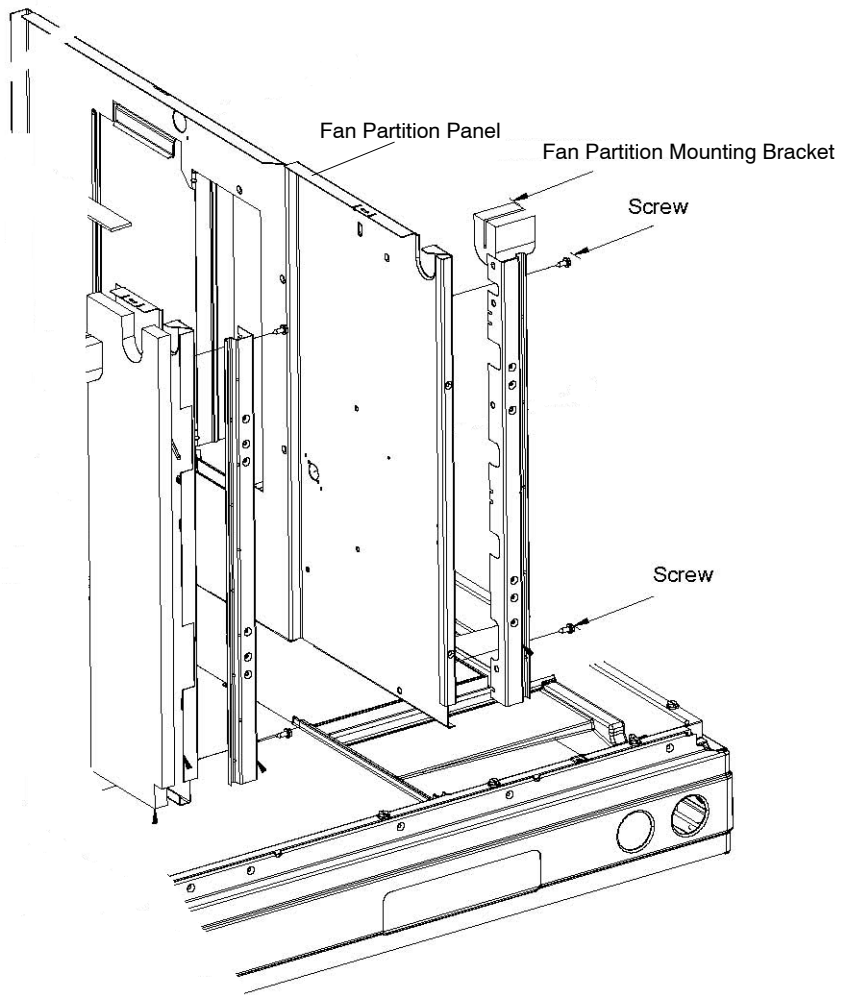

Table 4 – Rated Heating Input, Propane Gas (0-2000 ft (0-610m) Altitude

NAMEPLATE INPUT (BTU/HR)	RATED HEATING INPUT PROPANE (BTU/HR)
40,000	38,000
60,000	53,000
90,000	79,000
115,000	103,000
130,000	116,000

Figure 10	Conversion Responsibility Label
------------------	--

<p>THIS FURNACE WAS CONVERTED ON — — TO PROPANE GAS <small>(DAY - MONTH - YEAR)</small></p> <p>KIT NO. NPLPCONV013A00 (0-2000 ft. above sea level) NPLPCONV014A00 (2001-6000 ft above seal level)</p> <p>BY:</p> <p>_____</p> <p>_____</p> <p>_____</p> <p><small>(Name and address of organization making this conversion), which accepts the responsibility that this conversion has been properly made.</small></p>	<p>CE GÉNÉRATEUR D’AIR CHAUD A ÉTÉ CONVERTI LE — — POUR <small>(JOUR - MOIS - ANNÉE)</small></p> <p>DE L’ENSEMBLE N°:</p> <p>KIT NO. NPLPCONV013A00 (0-2000 ft. above sea level) NPLPCONV014A00 (2001-6000 ft above seal level)</p> <p>PAR:</p> <p>_____</p> <p>_____</p> <p>_____</p> <p><small>(nom et adresse de l’organisme qui a effectué la conversion), qui accepte l’entière responsabilité de la conversion.</small></p>
--	---

