

INSTALLATION INSTRUCTIONS

FOR NATURAL GAS TO PROPANE CONVERSION KIT

NAHA00701LP OR PART NO. 1178473

CONVERT Model "Series"	BTUH
N9MP1 "C"	40, 60, 80
N9MP2 "C"	80
N9MPD "A"	40, 60, 80
*9MPD "C"	80
*9UHX "A"	60, 80, 100
*9MPX "A"	60, 80, 100

* Denotes Brand (T, H or C)

SAFETY CONSIDERATIONS

Improper installation, adjustment, alteration, service, maintenance, or use can cause explosion, fire, electrical shock, or other conditions which may cause death, personal injury, or property damage. Consult a qualified installer, service agency, or your distributor or branch for information or assistance. The qualified installer or agency must use factory-authorized kits or accessories when modifying this product. Refer to the individual instructions packaged with the kits or accessories when installing.

Follow all safety codes. Wear safety glasses, protective clothing, and work gloves. Use quenching cloth for brazing operations. Have fire extinguisher available. Read these instructions thoroughly and follow all warnings or cautions included in literature and attached to the unit. Consult local building codes, the current editions of the National Fuel Gas Code (NFCG) NFPA 54/ANSI Z223.1, National Electrical Code (NEC) NFPA 70.

In Canada refer to the current editions of the National standards of Canada CAN/CSA-B149.1 and .2 Natural Gas and Propane Installation Codes, and Canadian Electrical Code CSA C22.1.

Recognize safety information. This is the safety-alert symbol . When you see this symbol on the unit and in instructions or manuals, be alert to the potential for personal injury. Understand these signal words; DANGER, WARNING, and CAUTION. These words are used with the safety-alert symbol. DANGER identifies the most serious hazards which **will** result in severe personal injury or death. WARNING signifies hazards which **could** result in personal injury or death. CAUTION is used to identify unsafe practices which **may** result in minor personal injury or product and property damage. NOTE is used to highlight suggestions which **will** result in enhanced installation, reliability, or operation.



General Information

This kit is for conversion of furnaces equipped with Honeywell VR8205S Series single stage gas valves certified for use with Natural Gas (and so marked) to units functionally the same as the certified furnace for use with Propane Gas. Before the furnace can be operated with Propane Gas, the low pressure switch must be installed. A gas valve conversion kit must be installed and main burner orifices must be replaced with orifices in this kit **or with properly sized orifices for high altitude (ordered separately).**

WARNING

FIRE, EXPLOSION, ELECTRIC SHOCK, AND CARBON MONOXIDE HAZARD.

This conversion kit shall be installed by a qualified service technician in accordance with the Manufacturer's instructions and all applicable codes and requirements of the authority having jurisdiction. If the information in these instructions is not followed exactly, a fire, an explosion or production of carbon monoxide could result causing property damage, personal injury or loss of life. The qualified service agency is responsible for the proper installation of this kit. The installation is not proper and complete until the operation of the converted appliance is checked as specified in the manufacturer's instructions supplied with the kit.

AVERTISSEMENT

Cette trousse de conversion doit être installée par un service d'entretien qualifié, selon les instructions du fabricant et selon toutes les exigences et tous les codes pertinents de l'autorité compétente. Assurez-vous de bien suivre les instructions dans cette notice pour réduire au minimum le risque d'incendie, d'explosion ou la production de monoxyde de carbone pouvant causer des dommages matériels, des blessures ou la mort. Le service d'entretien qualifié est responsable de l'installation de cette trousse. L'installation n'est pas adéquate ni complète tant que le bon fonctionnement de l'appareil converti n'a pas été vérifié selon les instructions du fabricant fournies avec la trousse.

This conversion kit shall be installed by a qualified service agency. Please read these instructions completely before attempting installation. Consult gas supplier and tables in National Fuel Gas Code NFPA 54/ANSI Z223.1-2009 or latest edition. In Canada, the National Standard CAN/CGA B149-1 and B149-2.

Parts List

Description	Part#	Qty.
Burner Orifice #55	1011354	6
Honeywell Conv. Kit (396221)	330733-401	1
Switch, Low Pressure(LGPS)	1008801	1
Fitting Asy.	1009775	1
Wire Asy.	1173071	1
Label, Field Conversion	1009678	1
Label, Derate	334836-101	1
Label, Conversion	336084-101	1
Label, Conversion	336085-101	1
Instructions	441 06 1082 01	1

Orifices for High Altitude Conversion (Not included in kit)

(Refer to **Table 1** – for required orifice)

Burner Orifice #56 1011355 as required

The orifices provided in this kit are stamped to indicate the size (twist drill number) and are sized for commercially pure propane gas ONLY. DO NOT use them with butane or a mixture of butane and propane gas. The parts list specifies the size orifices supplied in the kit. Compare the size marking on the orifices with the sizes as listed in the parts list. Make sure you have the correct main burner orifices.

Extreme care is used to assure that this kit contains the proper orifices. **Oversized orifices could result in hazardous conditions, especially if the venting is inadequate.** For that reason, we recommend that the installer check the size of the orifice with a new twist drill of the correct size. This procedure assures that the orifices provided are the correct size.

Installation

	WARNING
ELECTRIC SHOCK, FIRE AND EXPLOSION HAZARD.	
<p>Failure to follow this warning could result in personal injury, death, equipment damage, and/or property damage.</p>	
<p>Turn OFF gas supply at manual gas valve before turning OFF electric power supply and starting conversion.</p>	
<p>Turn OFF electric power supply at disconnect switch or service panel before starting conversion. Tag and lockout shutoff(s) with appropriate device warning labels. There may be more than one disconnect.</p>	

Disassembly

Refer to **Figure 1** and the following steps.

1. After disconnecting power and gas supply to the furnace, remove the access door, exposing gas valve and burner compartment.
2. Disconnect gas line from gas valve so manifold assembly can be removed.
3. Disconnect wiring at gas valve. Be sure to note the proper location of any and all electrical wiring disconnected.
4. Remove the four (4) screws holding the manifold and gas valve to the manifold supports. Do not discard any screws.
5. Carefully remove the manifold assembly.

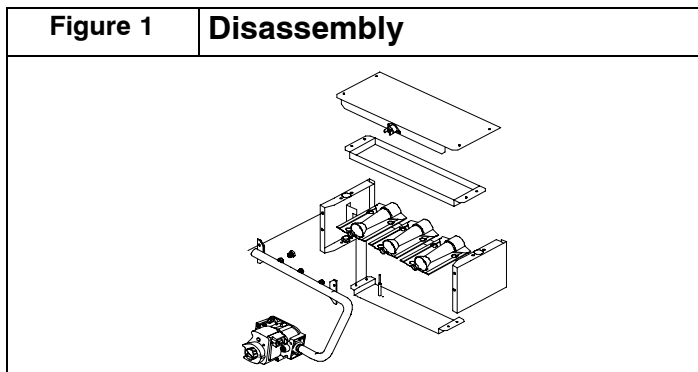

Main Burner Orifices

1. Remove the Natural gas (typically black) burner orifices from the manifold assembly and replace them with the appropriate Propane (silver) orifices furnished in the conversion kit unless converting a high altitude unit, then see **Table 1** for appropriate orifices (**Figure 2**).

2. Tighten the orifices so they are seated and gas tight about 1-1/8" (28.6mm) from the face of the orifice to the back of the manifold pipe (**Figure 2**). Make sure orifice is installed straight so that it forms a right angle (90°) to the manifold.

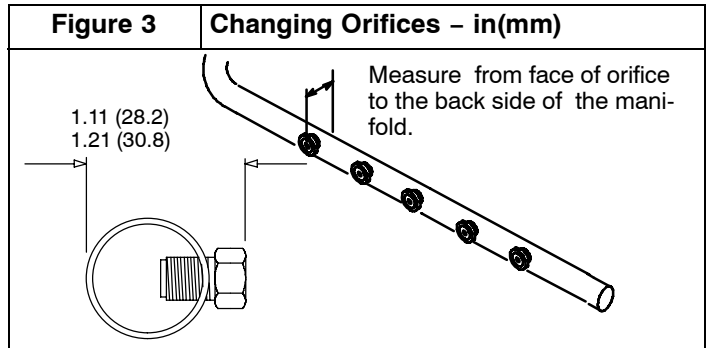
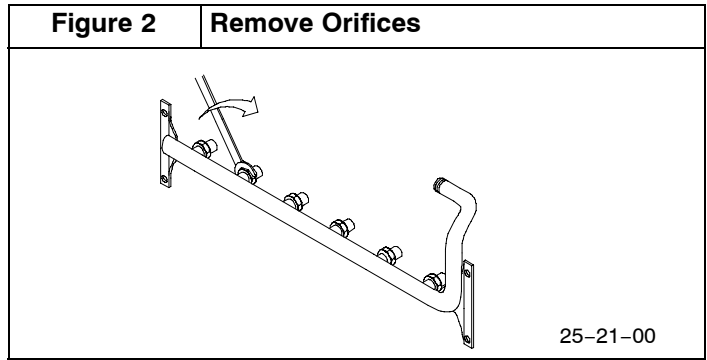

High Altitude Installation

Gas input rate on the furnace rating plate is for installation at up to 2000' (609.6m). The #55 burner orifices supplied in this kit are sized for Propane Gas at full rate ONLY, for use between 0-2000' (0 - 609.6m) elevation. Do not use them above 2000' (609.6m) except when noted by **Table 1**. Orifices for conversion at high altitude must be ordered from Service Parts.

In the USA, derating of these furnaces at 2% (Natural Gas) and 4% (Propane Gas) has been tested and design-certified by CSA.

† **In Canada**, the input rating must be derated 5% (Natural Gas) and 10% (Propane Gas) for altitudes of 2,000 to 4,500 (609.6 to 1371.6m) above sea level. Use the 2001 to 3000 (609.9 to 914.4m) column in **Table 1**.

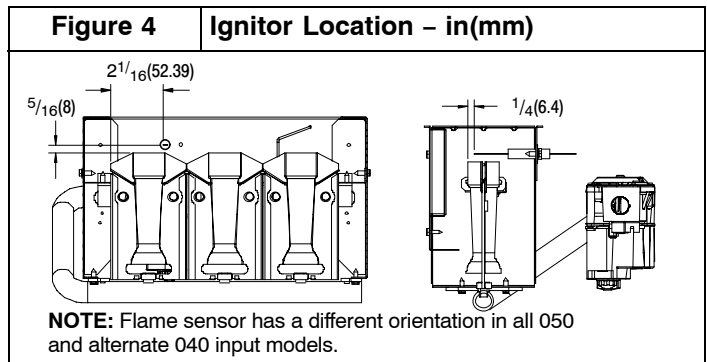

MANIFOLD PRESSURE AND ORIFICE SIZE

Table 1		PROPANE GAS MANIFOLD PRESSURE (in. w.c.) 20,000 BTUH per burner						
HEATING VALUE BTU/CU. FT.	FURNACE INPUT BTU/ BURNER	MEAN ELEVATION FEET ABOVE SEA LEVEL ft (m)						
		0 to 2000 (0 to 610)	2001 to 3000† (610.1 to 914)†	3001 to 4000 (914.1 to 1219)	4001 to 5000 (1219.1 to 1524)	5001 to 6000 (1524.1 to 1829)	6001 to 7000 (1829.1 to 2134)	7001 to 8000 (2134.1 to 2438)
2500	20000	10.0	8.9	8.4	10.0	10.0	10.0	10.0
Orifice Size		#55	#55	# 55	#56	#56	#56	#56
2500	19500‡	9.9	8.4	8.0	10.0	10.0	10.0	9.6
Orifice Size		#55	#55	# 55	#56	#56	#56	#56

‡ Applies to *9MPX 100,000 BTU models only, when installed in the downflow or horizontal applications

Conversion: 1 in. w.c. = .25 kPa
NOTE: Propane data is based on 1.53 specific gravity. For fuels with different specific gravity consult the National Fuel Gas Code ANSI Z223.1/NFPA 54–2009 or National Standard of Canada, Natural Gas and Propane Installation Code CSA B149.1–10.

In the USA, derating of these furnaces at 2% (Natural Gas) and 4% (Propane Gas) has been tested and design-certified by CSA.
 † In Canada, the input rating must be derated 5% (Natural Gas) and 10% (Propane Gas) for altitudes of 2,000 to 4,500 (609.6 to 1371.6m) above sea level. Use the 2001 to 3000 (609.9 to 914.4m) column in Table 1.

Gas Valve Conversion

Conversion of Honeywell VR8205S Gas Valve using Propane Gas Conversion Kit # 396221.

1. Remove the cap screw and pressure regulator adjusting screw. (See Figure 5 or Figure 6)
2. Remove the existing regulator spring from the regulator housing.
3. Insert the replacement spring (red color) contained in this kit into regulator housing.
4. Install the pressure regulator adjusting screw and give it eleven full clockwise turns. This will set the manifold pressure close to required setting for normal operation.
5. Replace the regulator cap screw.
6. Attach the Yellow Attention Label contained in the kit to the Gas Valve where it can be readily seen.

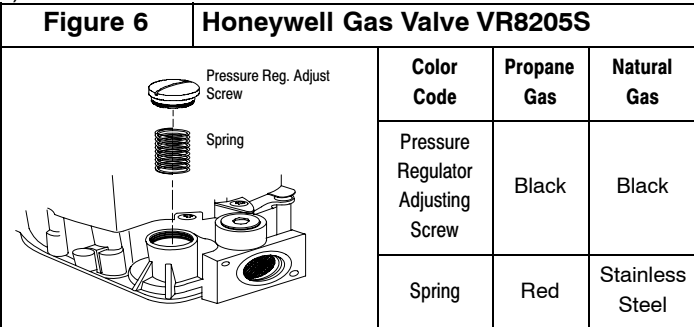
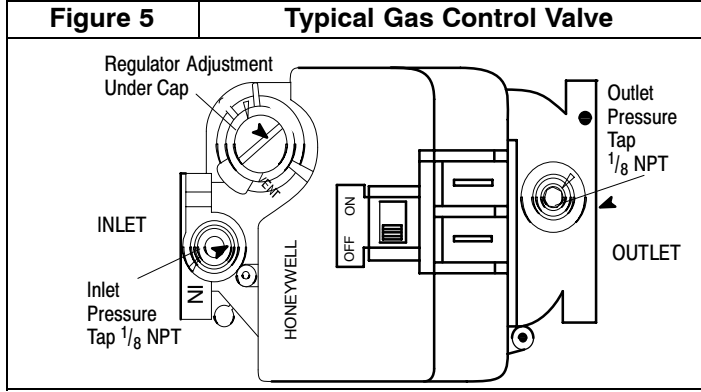

Propane Low Pressure Switch (Required)

1. Using pipe joint compound that is resistant to Propane gas, tighten the fitting assembly into the inlet side of the gas valve. (Figure 7). Position fitting assembly as shown.
 2. Screw the Propane pressure switch into the bushing. Use pipe dope on connection. Tighten securely.
- Note:** Do not block inlet port of pressure switch with pipe dope. Switch will not operate if inlet port is blocked.
3. Remove one yellow wire from the air pressure switch. Connect this wire to the male terminal of the insulated yellow wire in the wire harness provided.
 4. Connect the other yellow wire in the harness to the open termination on the air pressure switch.
 5. Connect the other end of the wire harness to the two terminals on the Propane switch.

Note: Propane switch is factory set to open if Propane gas supply pressure falls below 6 in. w.c. (1.5 kPa).
Note: See Furnace Wiring Label, to confirm wiring.

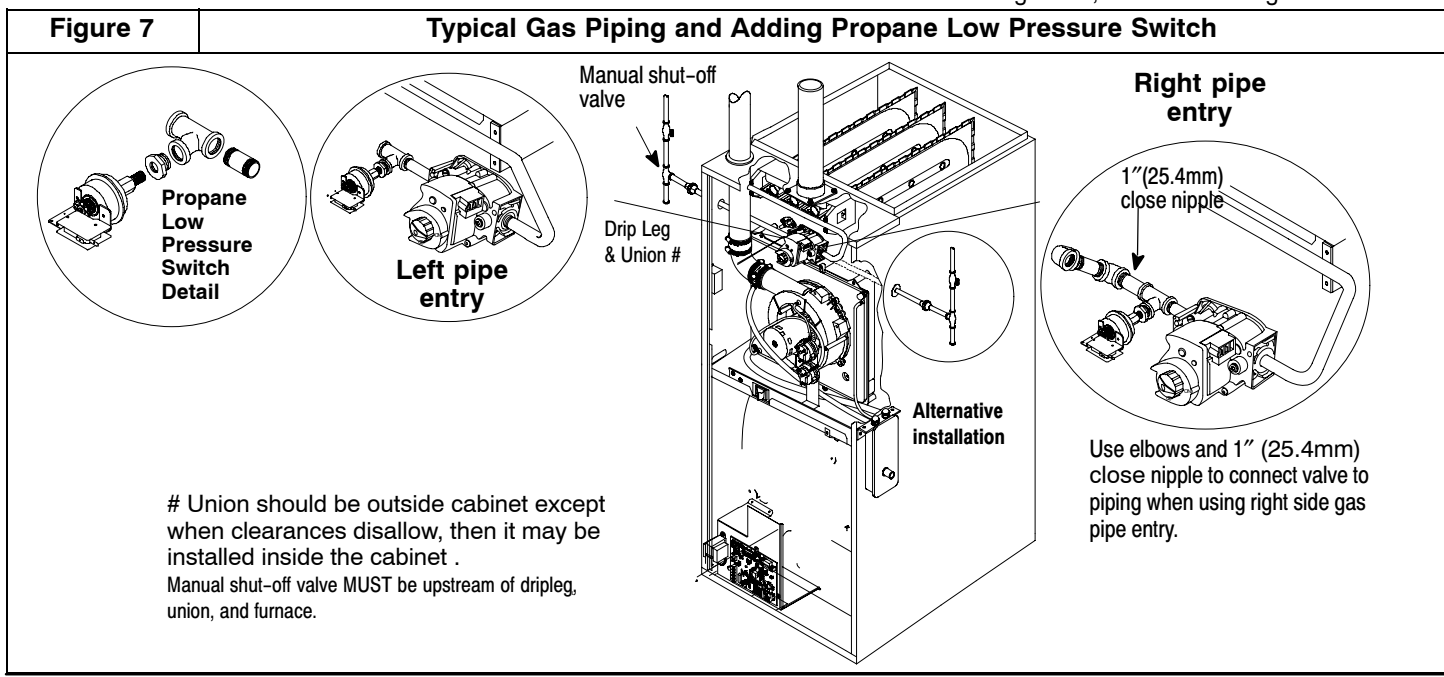

Reassembly

Reassemble all parts in reverse order as removed. Attach Propane Conversion Label next to the furnace rating plate or to the front exterior of the furnace.

- **Manifold Assembly** – Be sure to engage the main burner orifices in the proper openings in the burners.
- Verify the ignitor is in the correct location. (See **Figure 4**)
- **Testing for leaks** – After reassembly, turn the gas on and check all joints for gas leaks using a commercially available soap solution made specifically for detection of leaks. All leaks must be repaired immediately.

Gas Pressure

- Refer to the furnace rating plate for the approved gas input rating.
- Gas input to burners **MUST NOT** exceed the rated input shown on rating plate.
- **Do NOT** allow minimum gas supply pressure to vary downward. Doing so will decrease input to furnace. Refer to **Table 2** for gas supply and manifold pressures.

Table 2		Gas Pressures – in. w.c. (kPa)		
Gas Type	Supply Pressure			Manifold Pressure
	Recommended	Max.	Min.	
Propane	11 (2.75)	14 (3.5)	11 (2.75)	10 (2.5) *
* See Table 1				
Important Notes				
<ul style="list-style-type: none"> • With Propane gas, the rated input is obtained when the BTU content is 2,500 BTU per cubic foot and manifold pressure set at 10 in. w.c. (2.5 kPa). • If Propane gas has a different BTU content, orifices MUST be changed by licensed Propane installer. • Measured input can NOT exceed rated input. • Any major change in gas flow requires changing burner orifice size. 				

Start-up and Check-out

1. Remove the plug from the Inlet Pressure Tap on gas valve and install a manometer. (**Figure 5**)
2. Open manual gas line valve to unit. Check for gas leaks and correct as necessary. Check supply pressure, 11 in. w.c. (2.75 kPa) recommended, 11 in. w.c. (2.75 kPa) – minimum, 14 in. w.c. (3.5 kPa) – maximum. If not within these limitations **DO NOT OPERATE FURNACE**, contact gas supplier.
3. Close manual gas line valve to unit, remove manometer and replace inlet pressure tap plug.

Gas Valve Adjustment

1. With the gas valve knob or switch in the OFF position, remove the pressure tap plug from the outlet end of the valve, and connect a “U” tube manometer to the pressure port. (See **Figure 5**)
2. Turn the gas valve knob or switch to the ON position and restore electrical power to unit. Cycle the main burner on and off several times to stabilize the pressure regulator diaphragm. This **MUST** be done before an accurate pressure reading can be obtained.
3. With the main burner on, read the manometer. For appropriate reading see **Table 1**. Turn pressure regulator adjusting screw clockwise to increase or counterclockwise to decrease manifold pressure. Burner Input must not exceed nameplate rating. **Refer to Section “Checking Input Rate”**.
4. Turn gas valve to OFF. Remove the manometer and replace the pressure tap plug and pressure regulator cap screw.
5. Start the main burners and check pressure tap plug for gas leaks.
6. With gas valve on, observe furnace through two or more complete cycles to be sure all controls are operating.

International Comfort Products, LLC
Lewisburg, TN 37091 U.S.A.

Checking Input Rate

***High Altitude Input Rate =
Nameplate Sea Level Input Rate x (Multiplier)**

Elevation ft (m)	High Altitude Multiplier Propane Gas*
0 – 2000' (0 – 608)	1.00
2001' – 3000' (609.9 – 914.4) †	0.90
3001' – 4000' (914.7 – 1219.2)	0.86
4001' – 5000' (1219.5 – 1524)	0.82
5001' – 6000' (1524.3 – 1828.8)	0.78
6001' – 7000' (1829.1 – 2133.6)	0.74
7001' – 8000' (2133.9 – 2438.4)	0.70

* Based on mid-range of elevation.

In the USA, derating of these furnaces at 2% (Natural Gas) and 4% (Propane Gas) has been tested and design-certified by CSA.

† **In Canada**, the input rating must be derated 5% (Natural Gas) and 10% (Propane Gas) for altitudes of 2,000 to 4,500 (609.6 to 1371.6m) above sea level. Use the 2001 to 3000 (609.9 to 914.4m) column in **Table 1**.

Main Burner Flame Check

Check for the following: (See **Figure 8**)

- Stable and blue flames. Dust may cause orange tips or wisps of yellow, but flames **MUST NOT** have solid, yellow tips.
- Flames extending directly from burner into heat exchanger.
- Flames do **NOT** touch sides of heat exchanger

If any problems with main burner flames are noted, it may be necessary to adjust gas pressures or check for drafts.

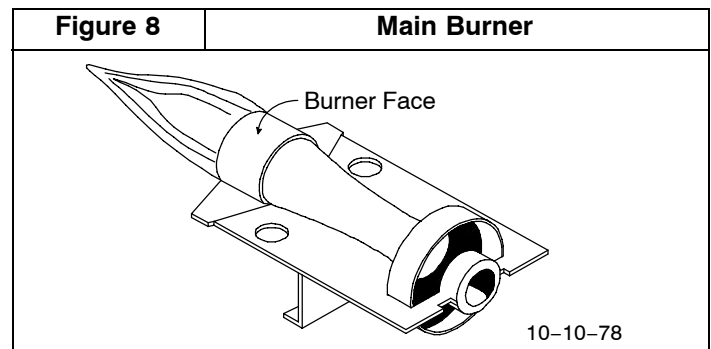

High Altitude Derated Unit Label

The derated label supplied with the conversion kit must be completed and affixed to the furnace near the rating plate. Fill in the manifold pressure, orifice size and revised input rate.

Refer to **Table 1** provided to determine the proper orifice part numbers for ordering purposes.

Verify System Operation

Upon completion of all conversion procedures, perform the following steps to attach the appropriate labels and verify the system operation.

1. Locate the Propane Conversion Label next to the furnace rating plate.
2. Fill out and attach the Field Conversion Label near the furnace rating plate or to the front exterior of the furnace.
3. Turn the thermostat to its lowest temperature setting or to OFF if equipped with a System Select Switch.
4. Turn the gas valve control knob or switch to ON.
5. Reinstall all access panels.
6. Turn ON all electrical power to the unit.
7. Set the thermostat to the desired temperature and the System Select Switch to HEAT.
8. Observe unit operation through two complete heating cycles. See “Sequence of Operation” in furnace installation instructions.