

HIGH EFFICIENCY 14 SEER HEAT PUMP ENVIRONMENTALLY SOUND R-410A REFRIGERANT

1½ THRU 5 TONS SPLIT SYSTEM
208 / 230 Volt, 1-phase, 60 Hz

REFRIGERATION CIRCUIT

- Copeland Scroll™ compressors on all models
- Crankcase Heater factory installed
- Suction line accumulator factory installed
- Bi-flow filter-drier included for field installation
- Integrated solid state control with Time-Temperature Defrost
- High and Low pressure switches
- Copper tube / aluminum fin coil

PERFORMANCE

- 2-speed Fan Motors factory wired on all models
- Compressor Sound Jacket standard

EASY TO INSTALL AND SERVICE

- Comfort Alert™ Diagnostics device on all models
- Easy Access service valves on all models
- Compressor access panel
- New, innovative control box design
- External high and low refrigerant service ports
- Fan motor in-line disconnect plug
- Only two screws to access control panel
- Factory charged with R-410A refrigerant

BUILT TO LAST

- High gloss, baked-on powder coat finish over galvanized steel
- Post-painted (black) coil fins
- SermaGard® coated cabinet screws
- Coated inlet grille with ⅜" spacing for extra protection
- Corner Posts for extra strength and style
- 7 year No-Hassle replacement limited warranty
- 10 year limited compressor, 7 year limited coil, and 5 year limited parts warranties



ARI Standard 210/240
Unitary Heat Pumps
Rated in accordance with ARI Standard 240.
Certification applies only when used with proper
components as listed with ARI.



Model Number	Size (tons)	Nominal Btu/hr	Min. Circuit Ampacity	Max. Fuse or Breaker	Operating Dimensions height x width x depth (in)	Ship / Operating Weight (lbs)
H4H418GKB	1½	18,000	12.0	20	33 ⁵ / ₁₆ x 35 x 36 ⁹ / ₁₆	224 / 195
H4H424GKC	2	24,000	16.7	25	33 ⁵ / ₁₆ x 35 x 36 ⁹ / ₁₆	267 / 233
H4H430GKC	2½	30,000	24.9	40	36 ³ / ₄ x 35 x 36 ⁹ / ₁₆	283 / 248
H4H436GKC	3	36,000	22.8	40	40 ¹ / ₈ x 35 x 36 ⁹ / ₁₆	299 / 264
H4H442GKC	3½	42,000	26.5	40	40 ¹ / ₈ x 35 x 36 ⁹ / ₁₆	327 / 292
H4H448GKC	4	48,000	30.9	50	43 ¹ / ₂ x 35 x 36 ⁹ / ₁₆	338 / 302
H4H460GKB	5	60,000	34.3	50	43 ¹ / ₂ x 35 x 36 ⁹ / ₁₆	329 / 296

Specifications subject to change without notice.

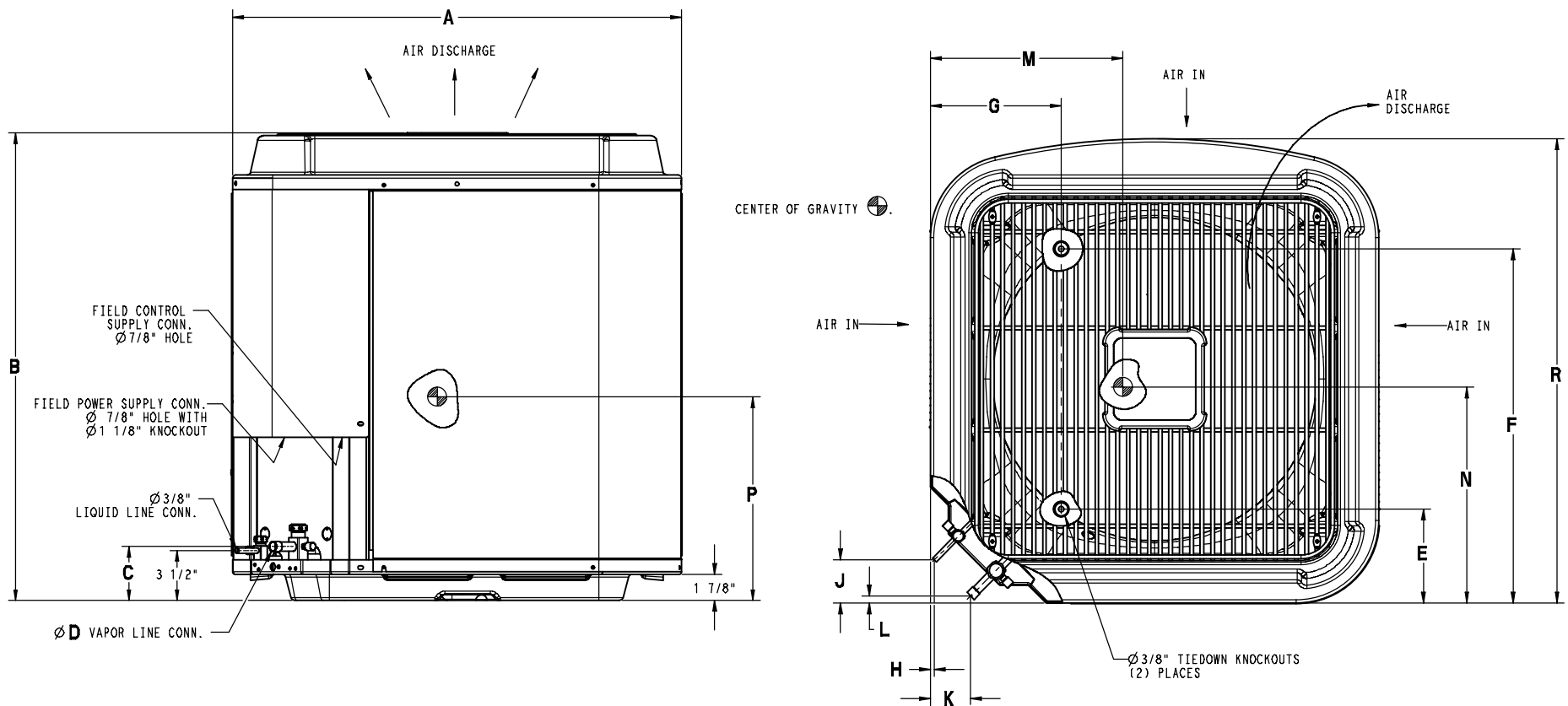

Model	All Dimensions Inches																Minimum Mounting Pad Size	Crated Dimensions B(h) x A(w) x R(d)
	A	B	C	D	E	F	G	H	J	K	L	M	N	P	R			
H4H418GKB	35	33 ⁵ / ₁₆	3 ³ / ₄	5 ⁵ / ₈	6 ⁹ / ₁₆	28 ⁷ / ₁₆	9 ¹ / ₈	1 ¹ / ₈	3 ¹³ / ₁₆	2 ¹³ / ₁₆	1/2	17 ¹ / ₄	17 ¹ / ₂	16	36 ⁹ / ₁₆	35 x 36 ¹ / ₂	37 ¹ / ₄ x 36 ¹ / ₈ x 37 ³ / ₄	
H4H424GKC	35	33 ⁵ / ₁₆	3 ³ / ₄	5 ⁵ / ₈	6 ⁹ / ₁₆	28 ⁷ / ₁₆	9 ¹ / ₈	1 ¹ / ₈	3 ¹³ / ₁₆	2 ¹³ / ₁₆	1/2	18	16 ¹ / ₂	16 ¹ / ₂	36 ⁹ / ₁₆	35 x 36 ¹ / ₂	37 ¹ / ₄ x 36 ¹ / ₈ x 37 ³ / ₄	
H4H430GKC	35	36 ³ / ₄	3 ³ / ₄	3 ³ / ₄	6 ⁹ / ₁₆	28 ⁷ / ₁₆	9 ¹ / ₈	1 ¹ / ₈	3 ¹³ / ₁₆	2 ¹³ / ₁₆	1/2	18	16 ³ / ₄	17	36 ⁹ / ₁₆	35 x 36 ¹ / ₂	40 ⁵ / ₈ x 36 ¹ / ₈ x 37 ³ / ₄	
H4H436GKC	35	40 ¹ / ₈	3 ³ / ₄	3 ³ / ₄	6 ⁹ / ₁₆	28 ⁷ / ₁₆	9 ¹ / ₈	1 ¹ / ₈	3 ¹³ / ₁₆	2 ¹³ / ₁₆	1/2	17 ¹ / ₂	16 ¹ / ₂	19 ¹ / ₂	36 ⁹ / ₁₆	35 x 36 ¹ / ₂	44 ¹ / ₁₆ x 36 ¹ / ₈ x 37 ³ / ₄	
H4H442GKC	35	40 ¹ / ₈	3 ⁷ / ₈	7 ⁷ / ₈	6 ⁹ / ₁₆	28 ⁷ / ₁₆	9 ¹ / ₈	1 ¹ / ₈	3 ¹³ / ₁₆	2 ¹⁵ / ₁₆	5 ⁵ / ₈	17 ¹ / ₂	16 ¹ / ₂	20	36 ⁹ / ₁₆	35 x 36 ¹ / ₂	44 ¹ / ₁₆ x 36 ¹ / ₈ x 37 ³ / ₄	
H4H448GKC	35	43 ¹ / ₂	3 ⁷ / ₈	7 ⁷ / ₈	6 ⁹ / ₁₆	28 ⁷ / ₁₆	9 ¹ / ₈	1 ¹ / ₈	3 ¹³ / ₁₆	2 ¹⁵ / ₁₆	5 ⁵ / ₈	17 ¹ / ₂	16 ¹ / ₂	20 ¹ / ₂	36 ⁹ / ₁₆	35 x 36 ¹ / ₂	47 ⁷ / ₁₆ x 36 ¹ / ₈ x 37 ³ / ₄	
H4H460GKB	35	43 ¹ / ₂	3 ⁷ / ₈	7 ⁷ / ₈	6 ⁹ / ₁₆	28 ⁷ / ₁₆	9 ¹ / ₈	1 ¹ / ₈	3 ¹³ / ₁₆	2 ¹⁵ / ₁₆	5 ⁵ / ₈	17 ¹ / ₄	16 ¹ / ₂	19	36 ⁹ / ₁₆	35 x 36 ¹ / ₂	47 ⁷ / ₁₆ x 36 ¹ / ₈ x 37 ³ / ₄	

Specifications subject to change without notice.

PHYSICAL DATA							
Model Size	18	24	30	36	42	48	60
Nominal Cooling Capacity (BTU/hr)	18,000	24,000	30,000	36,000	42,000	48,000	60,000
Nominal SEER	14.0	14.0	14.0	14.0	14.0	14.0	14.0
Sound Rating							
High Speed Fan (dBA)	73	74	72	72	73	73	74
Low Speed Fan (dBA)	73	70	70	71	73	71	72
PSC Fan Motor HP	1/10	1/10	1/10	1/5	1/5	1/4	1/4
Fan RPM High	825	803	805	831	825	819	820
Fan RPM Low	750	696	716	779	769	743	750
Fan CFM (High)	2595	2595	2595	3265	3265	3673	3673
Coil Face Area (ft ²)	16.26	16.26	18.30	20.33	20.33	22.36	22.40
Coil Rows–fins per inch	1–20	2–20	2–20	2–20	2–20	2–20	2–20
Low Pressure Switch							
Open Pressure (psig)	23 ± 5	23 ± 5	23 ± 5	23 ± 5	23 ± 5	23 ± 5	23 ± 5
Close Pressure (psig)	55 ± 5	55 ± 5	55 ± 5	55 ± 5	55 ± 5	55 ± 5	55 ± 5
High Pressure Switch							
Open Pressure (psig)	670 ± 10	670 ± 10	670 ± 10	670 ± 10	670 ± 10	670 ± 10	670 ± 10
Close Pressure (psig)	470 ± 25	470 ± 25	470 ± 25	470 ± 25	470 ± 25	470 ± 25	470 ± 25
Liquid Line Connection Size (in.)	3/8	3/8	3/8	3/8	3/8	3/8	3/8
Vapor Line Connection Size (in.)	5/8	5/8	3/4	3/4	7/8	7/8	7/8
Recommended Line Set Liquid Tube Diameter (in.)	3/8	3/8	3/8	3/8	3/8	3/8	3/8
Recommended Line Set Vapor Tube Diameter (in.) *	5/8 *	5/8 *	3/4 *	3/4 *	7/8 *	7/8 *	1 1/8 *
* Recommended Vapor Tube Line size is for standard installations. These recommendations may not apply to “Long Line” installations. When the total equivalent line length exceeds 80 feet or there is more than 20 feet vertical separation between indoor and outdoor units, consult the Long Line Application Guideline document before purchasing/installing line sets.							
Factory Charge R–410A (lbs.)	6.13	9.75	12.0	13.5	12.5	12.0	12.5
Required Subcooling (°F)	12	11	10	12	10	10	11
Outdoor Unit Factory Piston Size (used in Outdoor Unit for heating mode)	42	46	52	59	63	67	73
Weight, shipping (lbs.)	223	267	283	299	327	338	328
Weight, operating (lbs.)	194	233	248	264	292	302	295

ELECTRICAL DATA (208/230–1–60, voltage range 197V – 253V)							
Model Size	18	24	30	36	42	48	60
Minimum Circuit Ampacity – MCA (amps)	12.0	16.7	24.9	22.8	26.5	30.9	34.3
Maximum OverCurrent Protective device – MOCP (amps)	20	25	40	40	40	50	50
Compressor RLA (Rated Load Amps)	9.0	12.8	19.4	17.4	20.3	23.6	26.4
LRA (Locked Rotor Amps)	48.0	58.3	73.0	79.0	109.0	117.0	134.0
Fan Motor FLA (Full Load Amps)	0.7	0.7	0.7	1.1	1.1	1.3	1.3

R-410A COOLING CAPACITY LOSS FOR VARIOUS LINE LENGTHS & TUBE DIAMETERS

Model Size	Liquid Line (in.)	Acceptable Vapor Line Sizes (in.)	Cooling Capacity Loss (%) at Total Equivalent Line Length (ft.) Refer to Long Line Application Guideline to calculate equivalent length										
			Standard Application			Long Line Application (Requires Accessories)							
			25'	50'	80'	81'	100'	125'	150'	175'	200'	225'	250'
18	3/8	1/2	1	2	3	3	4	6	7	8	9	10	12
		5/8	0	0	1	1	1	1	2	2	3	3	3
24		5/8	0	1	1	1	2	3	3	4	4	5	6
		3/4	0	0	0	0	0	1	1	1	1	1	2
30		5/8	1	2	3	3	3	4	5	6	7	8	9
		3/4	0	0	1	1	1	1	2	2	2	3	3
		7/8	0	0	0	0	0	1	1	1	1	1	1
36		5/8	1	2	4	4	5	6	7	9	10	11	13
		3/4	0	0	1	1	1	2	2	3	3	4	4
		7/8	0	0	0	0	0	1	1	1	1	2	2
42		3/4	0	1	2	2	2	3	4	4	5	6	6
		7/8	0	0	1	1	1	1	2	2	2	3	3
48	3/4	0	1	2	2	3	4	5	5	6	7	8	
	7/8	0	0	1	1	1	2	2	2	3	3	4	
60	3/4	1	2	4	4	5	6	7	9	10	11	12	
	7/8	0	1	2	2	2	3	4	4	5	5	6	
	1 1/8	0	0	0	0	1	1	1	1	1	1	2	

* Applications are considered "Long Line" if the total equivalent tubing length exceeds 80 feet or there is more than 20 foot vertical separation between indoor and outdoor units). These applications require additional accessories and system modifications for reliable system operation.

Applications in shaded area may have height restrictions that limit allowable total equivalent length when outdoor unit is below indoor unit.

ACCESSORY USAGE GUIDELINES			
Accessory	REQUIRED FOR APPLICATIONS IN SNOW-BELT REGION	REQUIRED FOR LOW-AMBIENT APPLICATIONS (Below 55° F)	REQUIRED FOR LONG-LINE APPLICATIONS* (Over 80 Ft.)
Evaporator Freeze Thermostat	No	Yes	No
Accumulator	Standard (factory installed)	Standard (factory installed)	Standard (factory installed)
Low Ambient Kit (Pressure Switch)	No	Yes	No
Hard Start Kit (Capacitor & Relay)	No	Yes	Yes
Support Feet, 4" tall	Yes	Recommended	No
Liquid Line Solenoid Valve	No	No	See Long-Line Application Guideline

* For Line Set lengths between 80 and 200 ft horizontal. or more than 20 ft indoor-outdoor vertical separation, refer to the Long Line Application Guideline document.

ACCESSORIES		
Part Number	Description	Used On Model Size
NASA001SC	Start Component – PTC Device	ALL
NASA001FS	Evaporator Freeze Thermostat	ALL
NASA001LS	Liquid Line Solenoid Valve, HP, R-22 or R-410A	ALL
NASA001TD	Time Delay Relay, Indoor Blower	ALL
NASA001AC	Anti-Cycle Timer (5 minute delay)	ALL
NASA005SC	Hard Start Kit (Capacitor & Relay)	ALL
NASA401LA	Low Ambient Kit (Pressure Switch), R-410A	ALL
NASA001SF	Support Feet, 4" tall	ALL
NASA00106SS	Snow Stand Kit	ALL
AXWR01DFC	Fossil Fuel Kit	ALL
EBAC05TXVX	TXV Kit, R-410A *	18, 24, 30
EBAC06TXVX	TXV Kit, R-410A *	36, 42
EBAC07TXVX	TXV Kit, R-410A *	48, 60

* ONLY converts Fan Coils equipped with factory installed R-22 TXV.

COOLING & HEATING PERFORMANCE FOR COMBINATION RATINGS

Current Indoor Models

Outdoor Model	Current Indoor Model (‡ tested combo)	Furnace Model	Factory Installed	Cool (95 °F)			SEER				Heat (47 °F)		Heat (17 °F)		HSPF	
				BTU/hr	S / T	EER	factory	with field TDR	with field R-410A TXV	with field R-410A TXV+TDR	BTU/hr	COP	BTU/hr	COP		
H4H418GKB	‡ FEM4X18****		TDR & TXV	17,800	0.76	12.00	14.50					18,000	3.62	10,400	2.34	8.20
	ED*4X18B**		TXV	17,400	0.76	10.80		13.20				18,000	3.34	10,800	2.20	7.80
	ED*4X18B**	MV08B15****	TDR & TXV	17,700	0.76	12.00	15.00					17,600	3.54	10,200	2.34	8.10
	ED*4X24B**		TXV	17,700	0.76	11.00		13.50				18,000	3.50	10,900	2.26	8.00
	ED*4X24B**	MV08B15****	TDR & TXV	18,000	0.76	12.50	15.00					17,900	3.72	10,400	2.40	8.40
	ED*4X24F**		TXV	17,500	0.76	11.00		13.50				18,000	3.50	10,900	2.26	8.00
	ED*4X24F**	MV12F19****	TDR & TXV	18,000	0.76	12.50	15.00					18,000	3.74	10,400	2.42	8.50
	EHD4X24A**		TXV	17,700	0.76	11.00		13.50				18,000	3.54	10,900	2.28	8.10
	EHD4X24A**	MV08B15****	TDR & TXV	18,000	0.76	12.50	15.00					17,900	3.68	10,300	2.38	8.40
	EHD4X24A**	MV12F19****	TDR & TXV	18,000	0.76	12.50	15.00					17,800	3.64	10,300	2.38	8.30
	EMA4X24D**		TXV	17,700	0.76	11.00		13.50				18,000	3.54	10,900	2.26	8.10
	FEM4X24****		TDR & TXV	18,000	0.76	12.00	15.00					18,000	3.66	10,400	2.38	8.30
	FS(M,U)4X18****		TDR & TXV	17,400	0.76	10.80	13.00					18,000	3.40	10,900	2.20	7.80
	FS(M,U)4X24****		TDR & TXV	17,600	0.76	10.80	13.20					18,000	3.40	10,900	2.22	7.80
H4H424GKC	‡ FVM4X24****		TDR&TXV	23,600	0.75	12.50	15.00					24,000	4.00	15,400	2.78	9.0
	ED*4X24B**		TXV	22,600	0.75	11.00		13.20				24,000	3.60	15,700	2.54	8.2
	ED*4X24B**	*8MPV050	TDR&TXV	22,800	0.75	11.50	14.00					24,000	3.74	15,400	2.64	8.5
	ED*4X24B**	MV08B15****	TDR&TXV	23,200	0.75	12.00	15.00					24,000	3.90	15,400	2.72	9.0
	ED*4X24F**		TXV	22,600	0.75	11.00		13.20				24,000	3.60	15,700	2.54	8.2
	ED*4X24F**	*8MPV075	TDR&TXV	23,000	0.75	12.00	14.50					24,000	3.82	15,300	2.70	8.7
	ED*4X24F**	*9MPV050	TDR&TXV	22,600	0.75	12.00	14.50					24,000	3.70	15,200	2.64	8.4
	ED*4X24F**	*9MPV075	TDR&TXV	22,800	0.75	12.00	14.50					24,000	3.72	15,200	2.64	8.5
	ED*4X24F**	MV12F19****	TDR&TXV	23,400	0.75	12.00	15.00					24,000	3.92	15,300	2.76	9.0
	ED*4X30B**		TXV	23,000	0.75	11.00		13.50				24,000	3.66	16,000	2.56	8.3
	ED*4X30B**	*8MPV050	TDR&TXV	23,200	0.75	12.00	14.50					24,000	3.74	15,500	2.66	8.5
	ED*4X30B**	MV08B15****	TDR&TXV	23,600	0.75	12.00	15.00					24,000	3.90	15,400	2.76	9.0
	ED*4X30F**		TXV	23,000	0.75	11.00		13.50				24,000	3.66	16,000	2.56	8.3
	ED*4X30F**	*8MPV075	TDR&TXV	23,400	0.75	12.00	15.00					24,000	3.86	15,300	2.74	9.0
	ED*4X30F**	*9MPV050	TDR&TXV	23,000	0.75	12.00	14.50					24,000	3.74	15,200	2.66	8.5
	ED*4X30F**	*9MPV075	TDR&TXV	23,200	0.75	12.00	14.50					24,000	3.76	15,300	2.68	8.6
	ED*4X30F**	MV12F19****	TDR&TXV	23,600	0.75	12.40	15.00					24,000	3.94	15,300	2.78	9.0
	EMA4X24D**		TXV	22,600	0.75	11.00		13.20				24,000	3.68	15,800	2.56	8.4
	EHD4X24A**		TXV	22,800	0.75	11.00		13.50				24,000	3.70	15,800	2.58	8.4
	EHD4X24A**	*8MPV050	TDR&TXV	23,000	0.75	11.50	14.00					24,000	3.78	15,500	2.64	8.6
EHD4X24A**	*8MPV075	TDR&TXV	23,400	0.75	12.00	14.50					24,000	3.90	15,700	2.70	9.0	
EHD4X24A**	*8MPV100	TDR&TXV	23,400	0.75	12.00	14.50					24,000	3.96	15,500	2.74	9.0	
EHD4X24A**	*8MPV125	TDR&TXV	23,400	0.75	12.00	15.00					24,000	3.96	15,500	2.74	9.0	
EHD4X24A**	*9MPV050	TDR&TXV	23,200	0.75	11.50	14.00					24,000	3.82	15,700	2.66	8.6	
EHD4X24A**	*9MPV075	TDR&TXV	23,200	0.75	11.50	14.00					24,000	3.82	15,700	2.64	8.6	
EHD4X24A**	*9MPV100	TDR&TXV	23,400	0.75	12.00	14.50					24,000	3.90	15,600	2.70	9.0	

- continued on next page -

COOLING & HEATING PERFORMANCE FOR COMBINATION RATINGS (continued)
Current Indoor Models

Outdoor Model	Current Indoor Model (‡ tested combo)	Furnace Model	Factory Installed	Cool (95 °F)			SEER				Heat (47 °F)		Heat (17 °F)		HSPF		
				BTU/hr	S / T	EER	factory	with field TDR	with field R-410A TXV	with field R-410A TXV+TDR	BTU/hr	COP	BTU/hr	COP			
H4H424GKC (continued)	EHD4X24A**	*9MPV125	TDR&TXV	23,400	0.75	12.00	14.50					24,000	3.94	15,500	2.72	9.0	
	EHD4X24A**	MV08B15****	TDR&TXV	23,400	0.75	12.00	15.00					24,000	3.96	15,400	2.74	9.0	
	EHD4X24A**	MV12F19****	TDR&TXV	23,600	0.75	12.00	15.00					24,000	4.00	15,400	2.76	9.0	
	EHD4X24A**	MV16J22****	TDR&TXV	23,600	0.75	12.00	15.00					24,000	4.02	15,400	2.78	9.0	
	EHD4X24A**	MV20N26****	TDR&TXV	23,600	0.75	12.50	15.00					24,000	4.02	15,300	2.78	9.0	
	EHD4X30A**		TXV	23,200	0.75	11.00		13.50				24,000	3.70	16,000	2.58	8.4	
	EHD4X30A**	*8MPV050	TDR&TXV	23,200	0.75	12.00	14.50					24,000	3.78	15,500	2.66	8.6	
	EHD4X30A**	*8MPV075	TDR&TXV	23,400	0.75	12.00	15.00					24,000	3.84	15,300	2.72	8.7	
	EHD4X30A**	*8MPV100	TDR&TXV	23,600	0.75	12.00	15.00					24,000	3.92	15,400	2.76	9.0	
	EHD4X30A**	*8MPV125	TDR&TXV	23,600	0.75	12.00	15.00					24,000	3.94	15,300	2.76	9.0	
	EHD4X30A**	*9MPV050	TDR&TXV	23,400	0.75	11.00	14.00					24,000	3.82	15,700	2.68	8.7	
	EHD4X30A**	*9MPV075	TDR&TXV	23,000	0.75	12.00	14.50					24,000	3.74	15,300	2.66	8.5	
	EHD4X30A**	*9MPV100	TDR&TXV	23,400	0.75	12.00	15.00					24,000	3.84	15,400	2.72	8.7	
	EHD4X30A**	*9MPV125	TDR&TXV	23,400	0.75	12.00	15.00					24,000	3.88	15,300	2.74	9.0	
	EHD4X30A**	MV08B15****	TDR&TXV	23,600	0.75	12.00	15.00					24,000	3.96	15,400	2.76	9.0	
	EHD4X30A**	MV12F19****	TDR&TXV	23,600	0.75	12.00	15.00					24,000	3.94	15,300	2.78	9.0	
	H4H430GKC	FS(M,U)4X24****		TDR&TXV	22,600	0.75	11.00	13.20					24,000	3.60	15,800	2.54	8.2
		FS(M,U)4X30****		TDR&TXV	22,800	0.75	11.00	13.50					24,000	3.68	15,800	2.58	8.4
FEM4X24****			TDR&TXV	22,800	0.75	11.00	14.00					24,000	3.70	15,600	2.60	8.5	
FEM4X30****			TDR&TXV	23,000	0.75	11.00	14.00					24,000	3.78	15,800	2.62	8.6	
‡ FVM4X36****			TDR&TXV	29,200	0.79	13.00	15.00					28,600	3.94	17,600	2.72	9.0	
ED*4X30B**			TXV	28,200	0.79	11.20		13.50				29,200	3.60	18,200	2.52	8.2	
ED*4X30B**		*8MPV050	TDR&TXV	28,200	0.79	11.50	14.00					28,800	3.62	17,900	2.54	8.2	
ED*4X30B**		MV08B15****	TDR&TXV	28,600	0.79	12.50	15.00					28,600	3.76	17,700	2.64	8.5	
ED*4X30F**			TXV	28,200	0.79	11.20		13.50				29,200	3.60	18,200	2.52	8.2	
ED*4X30F**		*8MPV075	TDR&TXV	28,600	0.79	12.00	14.50					28,400	3.74	17,600	2.62	8.4	
ED*4X30F**		*9MPV050	TDR&TXV	28,600	0.79	11.20	13.50					29,200	3.66	18,200	2.54	8.3	
ED*4X30F**		*9MPV075	TDR&TXV	28,600	0.79	12.00	14.00					29,000	3.70	18,100	2.58	8.4	
ED*4X30F**	MV12F19****	TDR&TXV	29,000	0.79	12.50	15.00					28,600	3.88	17,700	2.70	8.7		
ED*4X36B**		TXV	28,400	0.79	11.20		13.50				29,400	3.66	18,400	2.54	8.3		
ED*4X36B**	*8MPV050	TDR&TXV	28,400	0.79	11.20	13.50					29,200	3.64	18,200	2.54	8.3		
ED*4X36B**	MV08B15****	TDR&TXV	28,800	0.79	12.50	15.00					28,600	3.80	17,700	2.66	8.6		
ED*4X36F**		TXV	28,400	0.79	11.20		13.50				29,400	3.66	18,400	2.54	8.3		
ED*4X36F**	*8MPV075	TDR&TXV	28,600	0.79	12.50	15.00					28,600	3.78	17,600	2.64	8.5		
ED*4X36F**	*9MPV050	TDR&TXV	28,400	0.79	12.00	14.50					28,400	3.66	17,600	2.58	8.3		
ED*4X36F**	*9MPV075	TDR&TXV	28,400	0.79	12.00	14.50					28,600	3.70	17,700	2.60	8.3		
ED*4X36F**	MV12F19****	TDR&TXV	29,200	0.79	12.50	15.00					28,800	3.92	17,700	2.72	9.0		
ED*4X36J**		TXV	28,400	0.79	11.20		13.50				29,400	3.66	18,400	2.54	8.3		
ED*4X36J**	*8MPV100	TDR&TXV	29,000	0.79	13.00	15.00					28,400	3.86	17,500	2.70	8.7		
ED*4X36J**	*8MPV125	TDR&TXV	29,000	0.79	13.00	15.00					28,400	3.88	17,500	2.70	8.7		
ED*4X36J**	*9MPV100	TDR&TXV	28,800	0.79	12.50	15.00					28,600	3.84	17,600	2.68	8.6		

- continued on next page -

COOLING & HEATING PERFORMANCE FOR COMBINATION RATINGS (continued)
Current Indoor Models

Outdoor Model	Current Indoor Model (‡ tested combo)	Furnace Model	Factory Installed	Cool (95 °F)			SEER				Heat (47 °F)		Heat (17 °F)		HSPF
				BTU/hr	S / T	EER	factory	with field TDR	with field R-410A TXV	with field R-410A TXV+TDR	BTU/hr	COP	BTU/hr	COP	
H4H430GKC (continued)	EMA4X36D**		TXV	28,400	0.79	11.20		13.50			29,400	3.64	18,300	2.54	8.3
	EHD4X30A**		TXV	28,400	0.79	11.20		13.50			29,200	3.64	18,300	2.54	8.3
	EHD4X30A**	*8MPV050	TDR&TXV	28,400	0.79	11.20	13.50				29,200	3.64	18,200	2.54	8.3
	EHD4X30A**	*8MPV075	TDR&TXV	28,800	0.79	12.00	14.50				29,000	3.78	18,000	2.62	8.5
	EHD4X30A**	*8MPV100	TDR&TXV	28,600	0.79	12.50	15.00				28,200	3.74	17,400	2.64	8.4
	EHD4X30A**	*8MPV125	TDR&TXV	28,600	0.79	12.50	15.00				28,200	3.74	17,400	2.64	8.4
	EHD4X30A**	*9MPV050	TDR&TXV	28,600	0.79	11.20	13.50				29,200	3.66	18,300	2.54	8.3
	EHD4X30A**	*9MPV075	TDR&TXV	28,600	0.79	11.50	14.00				29,200	3.70	18,100	2.56	8.4
	EHD4X30A**	*9MPV100	TDR&TXV	28,400	0.79	12.50	15.00				28,400	3.70	17,500	2.60	8.4
	EHD4X30A**	*9MPV125	TDR&TXV	28,600	0.79	12.50	15.00				28,200	3.72	17,400	2.62	8.4
	EHD4X30A**	MV08B15****	TDR&TXV	28,800	0.79	12.50	15.00				28,600	3.80	17,700	2.66	8.6
	EHD4X30A**	MV12F19****	TDR&TXV	29,000	0.79	12.50	15.00				28,600	3.86	17,700	2.68	8.7
	EHD4X36A**		TXV	29,000	0.79	11.20		13.50			29,600	3.78	18,500	2.58	8.5
	EHD4X36A**	*8MPV050	TDR&TXV	29,000	0.79	12.00	14.00				29,600	3.80	18,400	2.60	8.5
	EHD4X36A**	*8MPV075	TDR&TXV	29,200	0.79	12.50	15.00				28,800	3.88	17,700	2.68	8.7
	EHD4X36A**	*9MPV050	TDR&TXV	28,800	0.79	12.00	14.50				28,800	3.78	17,800	2.62	8.5
	EHD4X36A**	*9MPV075	TDR&TXV	29,000	0.79	12.00	14.50				28,800	3.80	17,800	2.62	8.5
	EHD4X36A**	*9MPV100	TDR&TXV	29,200	0.79	12.50	15.00				28,800	3.90	17,700	2.68	8.7
	EHD4X36A**	MV08B15****	TDR&TXV	29,400	0.79	13.00	15.00				29,000	3.98	17,800	2.72	9.0
	FS(M,U)4X30****		TDR&TXV	28,200	0.79	11.20	13.50				29,200	3.64	18,200	2.52	8.2
	F5U4X36****		TDR&TXV	28,400	0.79	11.00	13.20				29,400	3.64	18,400	2.52	8.2
	FEM4X30****		TDR&TXV	28,400	0.79	12.00	14.00				29,000	3.72	18,000	2.58	8.4
	F5M4X36****		TDR&TXV	29,000	0.79	11.20	13.50				29,600	3.74	18,400	2.56	8.4
FEM4X36****		TDR&TXV	29,400	0.79	12.50	15.00				29,000	3.96	17,900	2.70	9.0	
FVM4X24****		TDR&TXV	29,000	0.79	12.50	15.00				29,000	3.88	17,800	2.66	8.7	
H4H436GKC	‡ FVM4X48****		TDR&TXV	36,000	0.78	13.00	15.00				36,000	4.00	21,800	2.76	9.0
	ED*4X36B**		TXV	34,200	0.78	11.20		13.50			35,200	3.44	21,600	2.44	7.9
	ED*4X36B**	*8MPV050	TDR&TXV	34,000	0.78	11.20	13.50				34,800	3.38	21,200	2.42	7.8
	ED*4X36B**	MV08B15****	TDR&TXV	34,800	0.78	12.00	14.00				35,200	3.58	21,400	2.52	8.2
	ED*4X36F**		TXV	34,600	0.78	11.20		13.50			35,600	3.50	21,800	2.46	8.0
	ED*4X36F**	*8MPV075	TDR&TXV	35,000	0.78	11.50	14.00				35,600	3.60	21,600	2.50	8.2
	ED*4X36F**	*9MPV050	TDR&TXV	34,200	0.78	11.20	13.50				35,000	3.44	21,400	2.44	7.9
	ED*4X36F**	*9MPV075	TDR&TXV	34,600	0.78	11.20	13.50				35,600	3.52	21,800	2.46	8.1
	ED*4X36F**	MV12F19****	TDR&TXV	35,000	0.78	12.50	15.00				34,800	3.64	21,000	2.56	8.3
	ED*4X36J**		TXV	34,600	0.78	11.20		13.50			35,600	3.50	21,800	2.46	8.0
	ED*4X36J**	*8MPV100	TDR&TXV	35,200	0.78	12.50	15.00				35,000	3.68	21,200	2.58	8.4
	ED*4X36J**	*8MPV125	TDR&TXV	35,200	0.78	12.50	15.00				34,800	3.68	21,000	2.58	8.4
	ED*4X36J**	*9MPV100	TDR&TXV	35,000	0.78	12.00	14.50				35,000	3.64	21,200	2.54	8.3
	ED*4X36J**	MV16J22****	TDR&TXV	35,600	0.78	12.50	15.00				35,000	3.78	21,000	2.64	8.6
	ED*4X42J**		TXV	35,000	0.78	11.20		13.50			35,800	3.56	21,800	2.48	8.1
	ED*4X42J**	*8MPV100	TDR&TXV	35,400	0.78	12.50	15.00				35,200	3.72	21,200	2.60	8.5

- continued on next page -

COOLING & HEATING PERFORMANCE FOR COMBINATION RATINGS (continued)
Current Indoor Models

Outdoor Model	Current Indoor Model (‡ tested combo)	Furnace Model	Factory Installed	Cool (95 °F)			SEER				Heat (47 °F)		Heat (17 °F)		HSPF	
				BTU/hr	S / T	EER	factory	with field TDR	with field R-410A TXV	with field R-410A TXV+TDR	BTU/hr	COP	BTU/hr	COP		
H4H436GKC (continued)	ED*4X42J**	*8MPV125	TDR&TXV	35,400	0.78	12.50	15.00					35,000	3.74	21,000	2.60	8.5
	ED*4X42J**	*9MPV100	TDR&TXV	35,400	0.78	12.00	14.50					35,200	3.68	21,200	2.58	8.4
	ED*4X42L**		TXV	35,000	0.78	11.20		13.50				35,800	3.56	21,800	2.48	8.1
	ED*4X42L**	*9MPV125	TDR&TXV	35,400	0.78	12.50	15.00					35,000	3.72	21,200	2.60	8.5
	EMA4X36D**		TXV	34,600	0.78	11.20		13.50				35,600	3.48	21,800	2.44	8.0
	EHD4X36A**		TXV	35,400	0.78	11.50		14.00				36,000	3.64	22,000	2.50	8.3
	EHD4X36A**	*8MPV050	TDR&TXV	34,800	0.78	12.00	14.00					35,200	3.54	21,400	2.48	8.1
	EHD4X36A**	*8MPV075	TDR&TXV	35,400	0.78	12.00	15.00					35,200	3.68	21,200	2.56	8.4
	EHD4X36A**	*8MPV100	TDR&TXV	35,800	0.78	12.50	15.00					35,400	3.78	21,400	2.62	8.6
	EHD4X36A**	*8MPV125	TDR&TXV	35,800	0.78	12.50	15.00					35,200	3.78	21,200	2.62	8.6
	EHD4X36A**	*9MPV050	TDR&TXV	35,000	0.78	12.00	14.00					35,400	3.58	21,400	2.50	8.2
	EHD4X36A**	*9MPV075	TDR&TXV	35,600	0.78	11.50	14.00					36,000	3.64	22,000	2.50	8.3
	EHD4X36A**	*9MPV100	TDR&TXV	35,800	0.78	12.50	15.00					35,400	3.74	21,400	2.58	8.5
	EHD4X36A**	*9MPV125	TDR&TXV	35,800	0.78	12.50	15.00					35,200	3.76	21,200	2.60	8.5
	EHD4X36A**	MV08B15****	TDR&TXV	36,000	0.78	12.00	14.50					35,600	3.76	21,600	2.60	8.5
	EHD4X36A**	MV12F19****	TDR&TXV	35,800	0.78	12.50	15.00					35,200	3.78	21,200	2.62	8.6
	EHD4X42A**		TXV	35,800	0.78	11.50		14.00				36,000	3.68	22,000	2.52	8.4
	EHD4X42A**	*8MPV050	TDR&TXV	35,200	0.78	12.00	14.00					35,400	3.58	21,400	2.50	8.2
	EHD4X42A**	*8MPV075	TDR&TXV	35,800	0.78	12.50	15.00					35,400	3.74	21,400	2.60	8.5
	EHD4X42A**	*8MPV100	TDR&TXV	36,000	0.78	12.50	15.00					35,400	3.84	21,400	2.64	8.7
	EHD4X42A**	*9MPV050	TDR&TXV	35,400	0.78	12.00	14.00					35,400	3.62	21,600	2.52	8.3
	EHD4X42A**	*9MPV075	TDR&TXV	35,400	0.78	12.00	14.50					35,400	3.66	21,400	2.54	8.3
	EHD4X42A**	*9MPV100	TDR&TXV	36,000	0.78	12.50	15.00					35,400	3.80	21,400	2.62	8.6
	EHD4X42A**	*9MPV125	TDR&TXV	36,000	0.78	12.50	15.00					35,400	3.82	21,200	2.64	8.6
	EHD4X42A**	MV08B15****	TDR&TXV	36,000	0.78	12.50	15.00					35,800	3.82	21,600	2.62	8.6
	EHD4X42A**	MV12F19****	TDR&TXV	36,000	0.78	12.50	15.00					35,800	3.90	21,600	2.66	9.0
	F5U4X36****		TDR&TXV	34,600	0.78	11.20	13.50					35,800	3.48	21,800	2.44	8.0
	FS(M,U)4X42****		TDR&TXV	35,400	0.78	11.20	13.50					36,000	3.58	22,000	2.48	8.2
	F5M4X36****		TDR&TXV	35,400	0.78	11.20	13.50					36,000	3.60	22,000	2.50	8.2
	F5M4X36****		TDR&TXV	36,000	0.78	12.50	15.00					35,400	3.78	21,400	2.62	8.6
F5M4X42****		TDR&TXV	36,000	0.78	12.50	15.00					35,400	3.80	21,400	2.62	8.6	
F5M4X36****		TDR&TXV	35,400	0.78	12.50	15.00					35,000	3.72	21,000	2.60	8.4	
‡ F5M4X48****		TDR&TXV	42,000	0.78	13.00	15.00					42,000	3.90	26,600	2.78	9.0	
H4H442GKC	ED*4X42J**		TXV	41,500	0.78	11.20		13.50				42,000	3.52	27,000	2.58	8.1
	ED*4X42J**	*8MPV100	TDR&TXV	41,500	0.78	12.00	14.50					41,000	3.60	26,200	2.66	8.3
	ED*4X42J**	*8MPV125	TDR&TXV	41,500	0.78	12.00	14.50					41,000	3.62	26,200	2.68	8.3
	ED*4X42J**	*9MPV100	TDR&TXV	41,500	0.78	12.00	14.00					41,000	3.58	26,400	2.64	8.2
	ED*4X42J**	MV16J22****	TDR&TXV	42,000	0.78	12.50	15.00					41,500	3.72	26,400	2.72	8.5
	ED*4X42L**		TXV	41,500	0.78	11.20		13.50				42,000	3.52	27,000	2.58	8.1
	ED*4X42L**	*9MPV125	TDR&TXV	41,500	0.78	12.00	14.50					41,000	3.60	26,200	2.66	8.2
	ED*4X48F**		TXV	42,000	0.78	11.50		14.00				42,000	3.74	27,400	2.66	8.5

- continued on next page -

COOLING & HEATING PERFORMANCE FOR COMBINATION RATINGS (continued)
Current Indoor Models

Outdoor Model	Current Indoor Model (‡ tested combo)	Furnace Model	Factory Installed	Cool (95 °F)			SEER				Heat (47 °F)		Heat (17 °F)		HSPF	
				BTU/hr	S / T	EER	factory	with field TDR	with field R-410A TXV	with field R-410A TXV+TDR	BTU/hr	COP	BTU/hr	COP		
H4H442GKC (continued)	ED*4X48F**	*8MPV075	TDR&TXV	42,000	0.78	12.00	14.50					42,000	3.72	26,800	2.68	8.5
	ED*4X48F**	*9MPV075	TDR&TXV	42,000	0.78	11.50	14.00					42,000	3.64	27,000	2.64	8.3
	ED*4X48J**		TXV	42,000	0.78	11.20			13.50			42,000	3.66	27,200	2.64	8.3
	ED*4X48J**	*8MPV100	TDR&TXV	42,000	0.78	12.50	15.00					41,500	3.76	26,400	2.72	8.5
	ED*4X48J**	*8MPV125	TDR&TXV	42,000	0.78	12.50	15.00					41,500	3.76	26,400	2.72	8.5
	ED*4X48J**	*9MPV100	TDR&TXV	42,000	0.78	12.00	14.50					42,000	3.70	26,600	2.70	8.5
	ED*4X48J**	MV16J22****	TDR&TXV	42,000	0.78	13.00	15.50					41,500	3.80	26,200	2.76	8.6
	ED*4X48L**		TXV	42,000	0.78	11.20			13.50			42,000	3.66	27,200	2.64	8.3
	ED*4X48L**	*9MPV125	TDR&TXV	42,000	0.78	12.00	14.50					41,500	3.72	26,400	2.70	8.5
	EMA4X48D**		TXV	42,000	0.78	11.20			13.50			42,000	3.60	27,200	2.62	8.2
	EHD4X42A**		TXV	42,000	0.78	11.20			13.50			42,000	3.66	27,200	2.64	8.3
	EHD4X42A**	*8MPV075	TDR&TXV	42,000	0.78	12.00	14.50					41,500	3.66	26,600	2.66	8.3
	EHD4X42A**	*8MPV100	TDR&TXV	42,000	0.78	12.50	15.00					41,500	3.74	26,400	2.72	8.5
	EHD4X42A**	*8MPV125	TDR&TXV	42,000	0.78	12.50	15.00					41,500	3.74	26,400	2.72	8.5
	EHD4X42A**	*9MPV075	TDR&TXV	42,000	0.78	11.50	14.00					42,000	3.56	26,800	2.62	8.2
	EHD4X42A**	*9MPV100	TDR&TXV	42,000	0.78	12.00	14.50					41,500	3.70	26,600	2.70	8.4
	EHD4X42A**	*9MPV125	TDR&TXV	42,000	0.78	12.50	15.00					41,500	3.70	26,400	2.70	8.4
	EHD4X42A**	MV16J22****	TDR&TXV	42,000	0.78	12.50	15.00					42,000	3.86	26,600	2.78	8.7
	EHD4X48A**		TXV	42,000	0.78	12.00			14.00			42,000	3.68	27,400	2.66	8.4
	EHD4X48A**	*8MPV075	TDR&TXV	42,000	0.78	12.00	14.50					42,000	3.68	26,800	2.68	8.4
	EHD4X48A**	*8MPV100	TDR&TXV	42,000	0.78	12.50	15.00					41,500	3.76	26,600	2.72	8.6
	EHD4X48A**	*8MPV125	TDR&TXV	42,000	0.78	12.50	15.00					41,500	3.76	26,400	2.74	8.6
	EHD4X48A**	*9MPV075	TDR&TXV	42,000	0.78	12.00	14.00					42,000	3.60	27,000	2.62	8.2
	EHD4X48A**	*9MPV100	TDR&TXV	42,000	0.78	12.00	14.50					42,000	3.72	26,600	2.70	8.5
	EHD4X48A**	*9MPV125	TDR&TXV	42,000	0.78	12.50	15.00					41,500	3.72	26,400	2.72	8.5
	FS(M,U)4X42****		TDR&TXV	42,000	0.78	11.20	13.50					42,000	3.54	27,400	2.58	8.1
	FS(M,U)4X48****		TDR&TXV	42,000	0.78	11.20	13.50					42,000	3.68	27,400	2.64	8.4
FEM4X42****		TDR&TXV	42,000	0.78	12.00	14.50					41,500	3.70	26,600	2.70	8.4	
FVM4X36****		TDR&TXV	41,000	0.78	12.00	14.50					40,500	3.52	25,800	2.64	8.1	
FVM4X60****		TDR&TXV	42,000	0.78	13.00						41,500	4.00	26,600	2.84	9.0	
H4H448GKC	‡ FVM4X48****		TDR&TXV	48,000	0.76	13.00	15.00					48,000	3.82	30,000	2.74	9.0
	ED*4X48F**		TXV	47,000	0.76	12.00			14.00			48,000	3.70	30,800	2.64	8.4
	ED*4X48J**		TXV	46,500	0.76	11.20			13.50			48,000	3.64	30,800	2.60	8.3
	ED*4X48J**	*8MPV100	TDR&TXV	47,000	0.76	12.00	14.00					48,000	3.76	30,600	2.68	8.6
	ED*4X48J**	*8MPV125	TDR&TXV	47,000	0.76	12.00	14.50					48,000	3.78	30,400	2.68	8.6
	ED*4X48J**	*9MPV100	TDR&TXV	47,000	0.76	12.00	14.00					48,000	3.72	30,800	2.64	8.5
	ED*4X48J**	MV16J22****	TDR&TXV	47,500	0.76	12.50	15.00					48,000	3.84	30,000	2.74	8.7
	ED*4X48L**		TXV	46,500	0.76	11.20			13.50			48,000	3.64	30,800	2.60	8.3
	ED*4X48L**	*9MPV125	TDR&TXV	47,000	0.76	12.00	14.00					48,000	3.74	30,600	2.66	8.5
	ED*4X60J**		TXV	47,500	0.76	12.00			14.00			48,000	3.70	30,800	2.64	8.4
	ED*4X60J**	*8MPV100	TDR&TXV	48,000	0.76	12.00	14.50					48,000	3.88	30,800	2.72	9.0
	ED*4X60J**	*8MPV125	TDR&TXV	48,000	0.76	12.50	15.00					48,000	3.90	30,600	2.74	9.0
	ED*4X60J**	*9MPV100	TDR&TXV	48,000	0.76	12.00	14.50					48,000	3.82	30,800	2.70	8.7

- continued on next page -

COOLING & HEATING PERFORMANCE FOR COMBINATION RATINGS (continued)
Current Indoor Models

Outdoor Model	Current Indoor Model (‡ tested combo)	Furnace Model	Factory Installed	Cool (95 °F)			SEER				Heat (47 °F)		Heat (17 °F)		HSPF
				BTU/hr	S / T	EER	factory	with field TDR	with field R-410A TXV	with field R-410A TXV+TDR	BTU/hr	COP	BTU/hr	COP	
H4H448GKC (continued)	ED*4X60L**		TXV	47,500	0.76	12.00		14.00			48,000	3.70	30,800	2.64	8.4
	ED*4X60L**	*9MPV125	TDR&TXV	48,000	0.76	12.00	14.50				48,000	3.82	30,800	2.70	8.7
	EMA4X48D**		TXV	46,000	0.76	11.20		13.50			48,000	3.58	30,600	2.58	8.2
	EHD4X48A**		TXV	47,000	0.76	12.00		14.00			48,000	3.68	30,800	2.62	8.4
	EHD4X48A**	*8MPV100	TDR&TXV	47,500	0.76	12.00	14.50				48,000	3.80	30,600	2.68	8.6
	EHD4X48A**	*8MPV125	TDR&TXV	47,500	0.76	12.00	14.50				48,000	3.82	30,600	2.70	8.6
	EHD4X48A**	*9MPV100	TDR&TXV	47,500	0.76	12.00	14.00				48,000	3.74	30,800	2.66	8.5
	EHD4X48A**	*9MPV125	TDR&TXV	47,500	0.76	12.00	14.50				48,000	3.76	30,600	2.66	8.6
	EHD4X48A**	MV16J22****	TDR&TXV	48,000	0.76	12.50	15.00				48,000	3.86	30,200	2.74	8.7
	EHD4X48A**	MV20N26****	TDR&TXV	48,000	0.76	12.50	15.00				48,000	3.96	30,800	2.76	9.0
	EHD4X60A**		TXV	47,500	0.76	12.00		14.00			48,000	3.72	30,800	2.64	8.5
	EHD4X60A**	*8MPV100	TDR&TXV	48,000	0.76	12.50	15.00				48,000	3.90	30,800	2.74	9.0
	EHD4X60A**	*8MPV125	TDR&TXV	48,000	0.76	12.50	15.00				48,000	3.92	30,600	2.76	9.0
	EHD4X60A**	*9MPV100	TDR&TXV	48,000	0.76	12.00	14.50				48,000	3.84	30,800	2.70	8.7
	EHD4X60A**	*9MPV125	TDR&TXV	48,000	0.76	12.00	14.50				48,000	3.86	30,800	2.72	9.0
	FS(M,U)4X48****		TDR&TXV	47,000	0.76	12.00	14.00				48,000	3.64	30,800	2.60	8.3
	FS(M,U)4X60****		TDR&TXV	47,500	0.76	12.00	14.00				48,000	3.72	31,000	2.64	8.5
	FEM4X48****		TDR&TXV	48,000	0.76	13.00	15.00				48,000	3.82	30,000	2.74	8.7
FEM4X60****		TDR&TXV	48,000	0.76	12.00	14.50				48,000	3.82	30,600	2.70	8.7	
‡ FEM4X60****		TDR & TXV	60,000	0.76	11.50	14.00				59,000	3.70	37,000	2.60	8.40	
H4H460GKB	ED*4X60J**		TXV	59,000	0.76	11.20		13.50			59,500	3.54	36,800	2.52	8.00
	ED*4X60J**	*8MPV100	TDR & TXV	58,500	0.76	11.20	13.50				58,500	3.50	36,200	2.52	7.90
	ED*4X60J**	*8MPV125	TDR & TXV	59,000	0.76	11.20	13.50				59,000	3.56	36,600	2.54	8.00
	ED*4X60J**	MV16J22****	TDR & TXV	59,500	0.76	11.20	13.50				59,000	3.64	36,600	2.60	8.20
	ED*4X60L**		TXV	59,500	0.76	11.00		13.20			59,500	3.58	37,200	2.54	8.10
	EHD4X60A**		TXV	59,000	0.76	11.00		13.20			59,500	3.64	37,200	2.56	8.20
	EHD4X60A**	*8MPV100	TDR & TXV	58,500	0.76	11.20	13.50				58,500	3.54	36,200	2.54	8.00
	EHD4X60A**	*8MPV125	TDR & TXV	59,000	0.76	11.20	13.50				59,000	3.60	36,600	2.56	8.10
	EHD4X60A**	MV16J22****	TDR & TXV	59,500	0.76	11.20	13.50				59,000	3.72	36,600	2.60	8.30
	EHD4X60A**	MV20N26****	TDR & TXV	59,500	0.76	11.50	14.00				59,000	3.72	36,400	2.62	8.30
	FS(M,U)4X60****		TDR & TXV	59,500	0.76	10.80	13.00				60,000	3.56	37,800	2.50	8.00
	FVM4X60****		TDR & TXV	59,500	0.76	11.50	14.00				59,000	3.68	36,000	2.62	8.30

OUTDOOR UNIT MODEL NUMBER IDENTIFICATION GUIDE (single phase)											
Digit Position:	1	2	3	4	5, 6	7	8	9	10	11	12
Example Part Number:	H	4	H	4	18	G	K	A	1	0	0
H = Heil Mainline N = Heil Entry BRANDING											
2 = R-22 4 = R-410A REFRIGERANT											
A = Air Conditioner H = Heat Pump TYPE											
3 = 13 SEER 4 = 14 SEER 5 = 15 SEER 6 = 16 SEER 7 = 17 SEER 8 = 18 SEER NOMINAL EFFICIENCY											
18 = 18,000 BTUH = 1½ tons 24 = 24,000 BTUH = 2 tons 30 = 30,000 BTUH = 2½ tons 36 = 36,000 BTUH = 3 tons 42 = 42,000 BTUH = 3½ tons 48 = 48,000 BTUH = 4 tons 60 = 60,000 BTUH = 5 tons NOMINAL CAPACITY											
A = Standard Grille G = Coil Guard Grille C = Coastal FEATURES											
K = 208/230-1-60 VOLTAGE											
Sales Code											
Engineering Revision											
Extra Digit											
Extra Digit											

ACCESSORIES PART NUMBER IDENTIFICATION GUIDE									
Digit Position:	1	2	3	4	5	6, 7	8, 9	10, 11	
Example Part Number:	N	A	S	A	0	01	01	CH	
N = Non-Branded BRANDING									
A = Accessory PRODUCT GROUP									
S = Split System (AC & HP) KIT USAGE									
A = Original B = 2nd Generation MAJOR SERIES									
0 = Generic or Not Applicable 2 = R-22 4 = R-410A REFRIGERANT									
Product Identifier Number									
Package Quantity									
Type of Kit (Example: CH = Crankcase Heater)									