

TECHNICAL SUPPORT MANUAL

Split System Heat Pump

N2H3

Safety Labeling and Signal Words

DANGER, WARNING, CAUTION, and NOTE

The signal words **DANGER**, **WARNING**, **CAUTION**, and **NOTE** are used to identify levels of hazard seriousness. The signal word **DANGER** is only used on product labels to signify an immediate hazard. The signal words **WARNING**, **CAUTION**, and **NOTE** will be used on product labels and throughout this manual and other manuals that may apply to the product.

DANGER - Immediate hazards which **will** result in severe personal injury or death.

WARNING - Hazards or unsafe practices which **could** result in severe personal injury or death.

CAUTION - Hazards or unsafe practices which **may** result in minor personal injury or product or property damage.

NOTE - Used to highlight suggestions which **will** result in enhanced installation, reliability, or operation.

Signal Words in Manuals

The signal word **WARNING** is used throughout this manual in the following manner:



The signal word **CAUTION** is used throughout this manual in the following manner:



Signal Words on Product Labeling

Signal words are used in combination with colors and/or pictures on product labels.

TABLE OF CONTENTS

Wiring Diagrams	2 - 3
Charging Chart	4
Tech Labels (Expanded Data)	5 - 12
Cooling Multiplying Factors	13 - 16
Heating Multiplying Factors	17 - 20
Exploded Drawings	21 - 23
Parts List	24 - 26
Model Number Identification	27

WARNING

DEATH, PERSONAL INJURY, AND/OR PROPERTY DAMAGE HAZARD

Failure to carefully read and follow this warning could result in equipment malfunction, property damage, personal injury and/or death.

Installation or repairs made by unqualified persons could result in equipment malfunction, property damage, personal injury and/or death.

The information contained in this manual is intended for use by a qualified service technician familiar with safety procedures and equipped with the proper tools and test instruments.

Installation must conform with local building codes and with the National Electrical Code NFPA70 current edition or Canadian Electrical Code Part 1 CSA C.22.1.

CONNECTION DIAGRAM

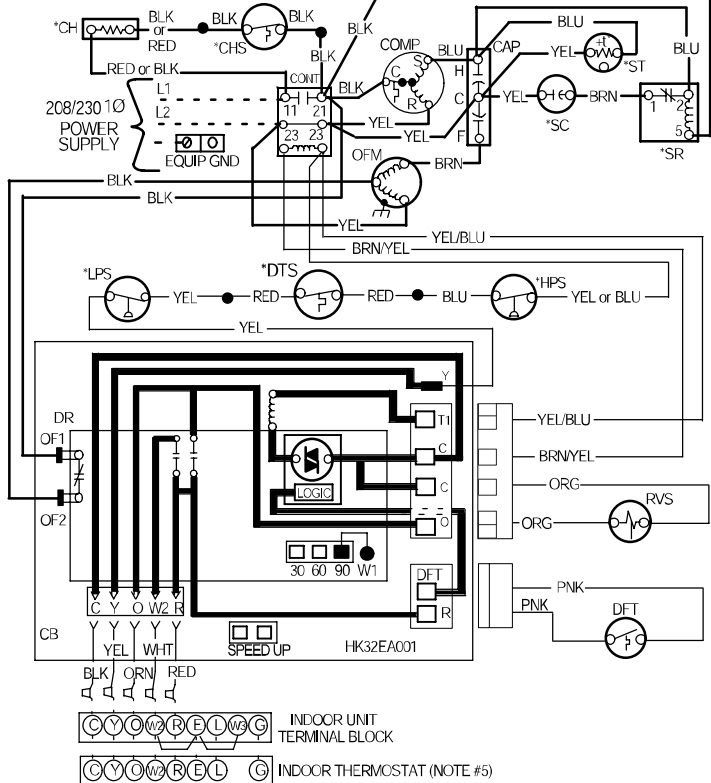

SCHEMATIC DIAGRAM (LADDER FORM)

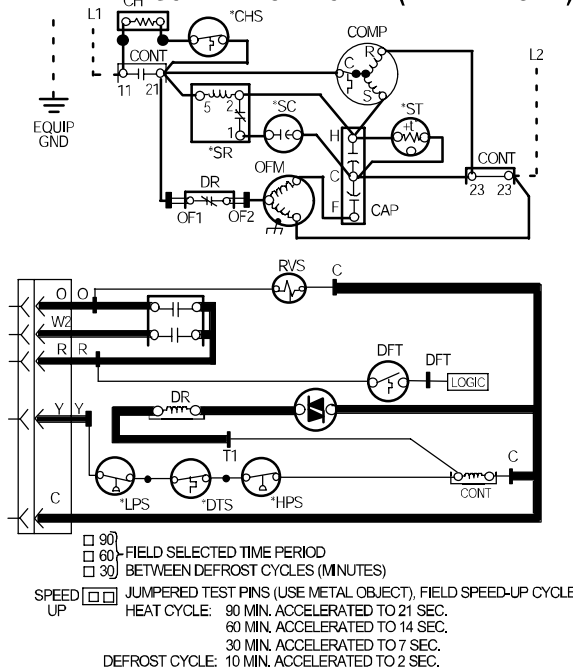

Model Sizes: 18, 24, 30, 36, 42, 48

-LEGEND-

- FACTORY POWER WIRING
- - - FIELD POWER WIRING
- FACTORY CONTROL WIRING
- - - FIELD CONTROL WIRING
- CONDUCTOR ON CIRCUIT BOARD
- COMPONENT CONNECTION
- 1/4-INCH QUICK CONNECT TERMINALS
- ⌋ FIELD SPlice
- JUNCTION
- CAP CAPACITOR (DUAL RUN)
- *CH CRANKCASE HEATER SWITCH
- COMP COMPRESSOR
- CONT CONTACTOR
- CB CIRCUIT BOARD
- DFT DEFROST THERMOSTAT
- DR DEFROST RELAY AND CIRCUITRY
- *DTS DISCHARGE TEMP. SWITCH
- *HPS HIGH PRESSURE SWITCH
- *LPS LOW PRESSURE SWITCH
- OFM OUTDOOR FAN MOTOR
- RVS REVERSING VALVE SOLENOID
- *SC START CAPACITOR
- *SR START RELAY
- *ST START THERMISTOR

* MAY BE FACTORY OR FIELD INSTALLED

1. Symbols are electrical representation only.
2. Compressor and fan motor furnished with inherent thermal protection.
3. To be wired in accordance with National Electric N.E.C. and local codes.
4. N.E.C. class 2, 24 V circuit, min. 40 VA required, 60 VA on units installed with LLS.
5. Connection for typical heat pump thermostat. For other arrangements see installation instructions.
6. Use copper conductors only. Use conductors suitable for at least 75 °C (167 °F).
7. If indoor section has a transformer with a grounded secondary, connect the grounded side to "C" on the circuit board.
8. When start capacitor and relay are installed, start thermistor (PTC) is not used.
9. CH not used on all units.
10. If any of the original wire, as supplied, must be replaced, use the same or equivalent wire.
11. Check all electrical connections inside control box for tightness.
12. Do not attempt to operate unit until service valves have been opened.
13. Do not rapid cycle compressor. Compressor must be off 3 minutes to allow pressures to equalize between high and low side before starting.

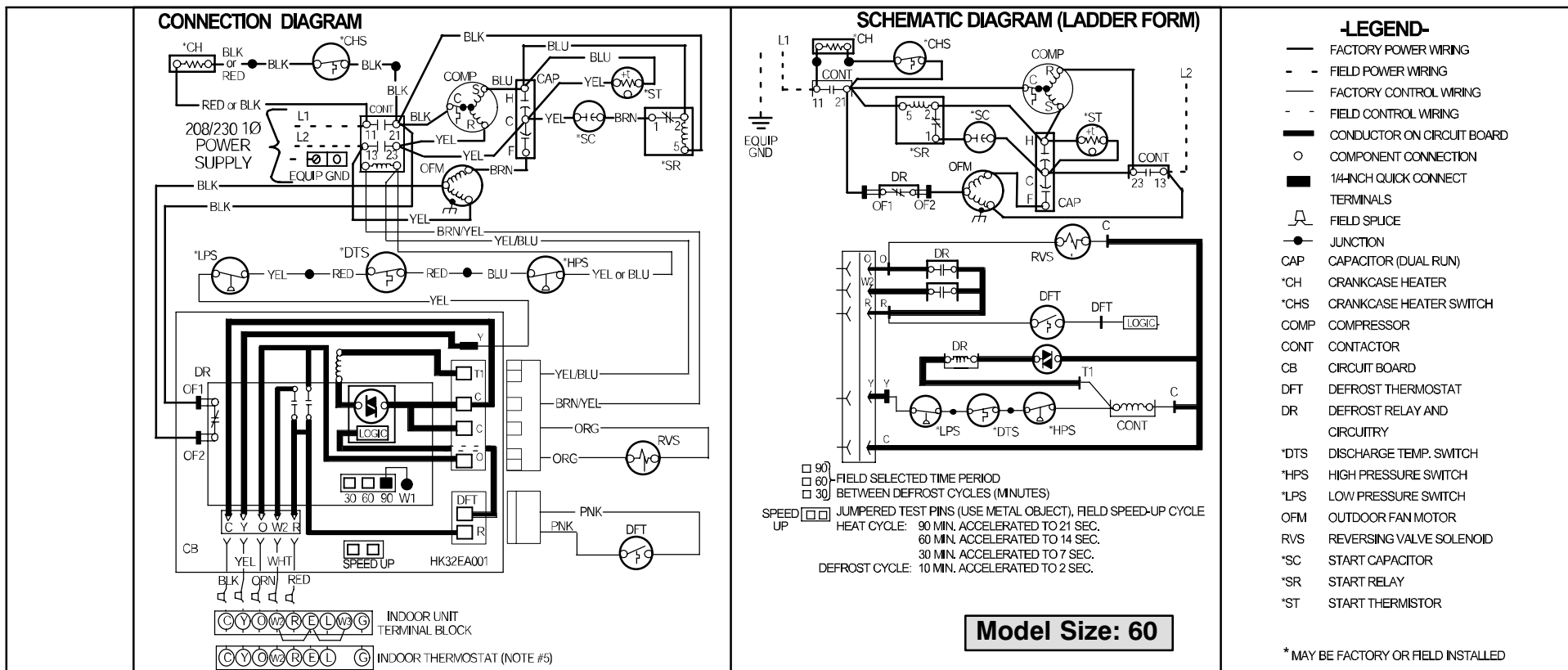

1. Symbols are electrical representation only.
2. Compressor and fan motor furnished with inherent thermal protection.
3. To be wired in accordance with National Electric N.E.C. and local codes.
4. N.E.C. class 2, 24 V circuit, min. 40 VA required, 60 VA on units installed with LLS.
5. Connection for typical heat pump thermostat. For other arrangements see installation instructions.
6. Use copper conductors only. Use conductors suitable for at least 75°C (167°F).
7. If indoor section has a transformer with a grounded secondary, connect the grounded side to "C" on the circuit board.
8. When start capacitor and relay are installed, start thermistor (PTC) is not used.
9. CH not used on all units.
10. If any of the original wire, as supplied, must be replaced, use the same or equivalent wire.
11. Check all electrical connections inside control box for tightness.
12. Do not attempt to operate unit until service valves have been opened.
13. Do not rapid cycle compressor. Compressor must be off 3 minutes to allow pressures to equalize between high and low side before starting.

R-22 CHARGING CHART

- Find the required Subcooling Temperature on the unit Rating Plate. Use the closest column on the chart below (5, 10, 15, or 20) .
- Add or remove refrigerant until both the Liquid Line Temperature and Liquid Pressure agree with chart data.

Measured Liquid Pressure (psig)	Rating Plate (required) Subcooling Temperature (°F)			
	5	10	15	20
	R-22 Required Liquid Line Temperature (°F)			
134	71	66	61	56
141	74	69	64	59
148	77	72	67	62
156	80	75	70	65
163	83	78	73	68
171	86	81	76	71
179	89	84	79	74
187	92	87	82	77
196	95	90	85	80
205	98	93	88	83
214	101	96	91	86
223	104	99	94	89
233	107	102	97	92
243	110	105	100	95
253	113	108	103	98
264	116	111	106	101
274	119	114	109	104
285	122	117	112	107
297	125	120	115	110
309	128	123	118	113
321	131	126	121	116
331	134	129	124	119
346	137	132	127	122
359	140	135	130	125

MULTIPLYING FACTORS

(Refer to pages 6-12)

- † Total capacities are net (I.D. blower heat subtracted) system capacities based on 25' line set.
If additional tubing length and/or indoor unit is located above outdoor unit, a slight variation in capacity may occur.
- †† At TVA rating indoor condition (75 °F db, 63 °F wb), all other indoor air temperatures are at 80 °F db
If additional tubing length and/or indoor unit is located above outdoor unit, a slight variation in capacity may occur.
- * System amps are total of indoor and outdoor amps.
- ‡ Chart data is for 80° F indoor dry bulb. For indoor db temperatures other than 80° F, measure Indoor db and Indoor CFM, and plug these into the formula below. Measure outdoor db and indoor wet bulb, apply these to the chart above, find MBh and S/T, and plug these into the formula below.
(Note: if indoor db is the only thing changing, total capacity, MBh, stays the same.)

$$\text{Sensible Capacity at Indoor db LOWER than } 80^{\circ}\text{F} = (\text{MBh} \times \text{S/T}) - \left(\frac{(80 - \text{Indoor db}) \times 835 \times \text{Indoor CFM}}{1000} \right)$$

$$\text{Sensible Capacity at Indoor db HIGHER than } 80^{\circ}\text{F} = (\text{MBh} \times \text{S/T}) + \left(\frac{(\text{Indoor db} - 80) \times 835 \times \text{Indoor CFM}}{1000} \right)$$

N2H318 COOLING		With FS(M,U)2X18 Indoor																								
		Outdoor Ambient Temperature - Degrees F, Dry Bulb																								
		75			85			95			105			115												
		Entering Indoor Temperature - Degrees F, Wet Bulb																								
CFM		72	67	63††	62	57	72	67	63††	62	57	72	67	63††	62	57	72	67	63††	62	57	72	67	63††	62	57
525	MBh†	20.06	18.25	16.94	16.64	16.16	19.34	17.57	16.28	16.00	15.64	18.59	16.85	15.59	15.35	15.10	17.79	16.09	14.88	14.67	14.53	16.96	15.30	14.13	13.95	13.94
	S/T‡	0.52	0.71	0.73	0.92	1.00	0.52	0.72	0.75	0.94	1.00	0.53	0.73	0.76	0.96	1.00	0.53	0.74	0.77	0.98	1.00	0.54	0.76	0.79	1.00	1.00
	AMPS*	5.19	5.17	5.15	5.15	5.15	5.79	5.76	5.75	5.74	5.74	6.45	6.43	6.41	6.40	6.40	7.19	7.16	7.14	7.14	7.13	8.01	7.97	7.94	7.94	7.94
	HI PR	162	160	159	159	159	189	188	186	186	186	220	217	216	216	215	253	250	249	248	248	289	287	285	284	284
	LO PR	86	78	72	71	69	88	80	74	73	71	89	81	75	74	73	90	82	76	75	75	92	84	78	77	77
600	MBh†	20.39	18.55	17.22	16.98	16.75	19.65	17.84	16.55	16.34	16.21	18.87	17.10	15.84	15.66	15.64	18.05	16.32	15.09	15.04	15.04	17.19	15.51	14.32	14.41	14.42
	S/T‡	0.53	0.74	0.76	0.96	1.00	0.54	0.75	0.78	0.98	1.00	0.54	0.76	0.79	1.00	1.00	0.55	0.78	0.81	1.00	1.00	0.56	0.80	0.83	1.00	1.00
	AMPS*	5.32	5.30	5.28	5.28	5.28	5.91	5.89	5.88	5.87	5.87	6.58	6.56	6.54	6.53	6.53	7.32	7.29	7.27	7.27	7.27	8.14	8.10	8.07	8.08	8.08
	HI PR	163	161	160	159	159	190	188	187	186	186	220	218	216	216	216	253	251	249	249	249	290	287	285	285	285
	LO PR	88	80	74	73	72	89	81	75	75	74	91	83	76	76	76	92	84	78	78	78	94	85	79	80	80
675	MBh†	20.63	18.77	17.44	17.27	17.24	19.87	18.05	16.74	16.67	16.68	19.07	17.28	16.01	16.08	16.08	18.23	16.49	15.25	15.46	15.46	17.35	15.66	14.47	14.80	14.81
	S/T‡	0.54	0.77	0.80	1.00	1.00	0.55	0.78	0.81	1.00	1.00	0.56	0.80	0.83	1.00	1.00	0.57	0.82	0.84	1.00	1.00	0.58	0.84	0.87	1.00	1.00
	AMPS*	5.44	5.42	5.41	5.41	5.41	6.04	6.02	6.00	6.00	6.00	6.71	6.68	6.66	6.67	6.67	7.45	7.42	7.40	7.40	7.40	8.26	8.23	8.20	8.21	8.21
	HI PR	163	161	160	160	160	190	188	187	187	187	220	218	217	217	217	254	251	250	250	250	290	288	286	286	286
	LO PR	90	82	76	75	75	91	83	77	77	77	92	84	78	78	78	94	85	79	80	80	95	87	80	82	82

N2H318 HEATING		With FS(M,U)2X18 Indoor																							
		Outdoor Ambient Temperature - Degrees F, Dry Bulb																							
		-3			7			17			27			37			47			57			67		
		Entering Indoor Temperature - Degrees F, Dry Bulb																							
CFM		65	70	75	65	70	75	65	70	75	65	70	75	65	70	75	65	70	75	65	70	75	65	70	75
525	MBh†	9.66	9.43	9.19	12.20	11.94	11.68	15.14	14.84	14.53	17.80	17.79	17.67	18.43	19.11	19.47	17.95	18.81	19.53	17.03	18.21	19.14	15.87	17.62	18.57
	T/R	13.50	13.30	13.00	17.10	16.90	16.70	21.40	21.20	20.90	25.40	25.60	25.70	26.30	27.60	28.40	25.60	27.20	28.50	24.20	26.20	27.90	22.50	25.40	27.00
	AMPS*	5.43	5.69	5.96	5.69	5.96	6.25	5.99	6.28	6.58	6.27	6.60	6.94	6.34	6.76	7.18	6.27	6.71	7.16	6.16	6.62	7.09	6.02	6.53	6.99
	HI PR	141	152	163	150	162	174	162	174	186	174	187	201	177	194	210	174	191	210	169	188	207	163	184	203
	LO PR	18	18	18	25	25	25	33	33	33	40	41	42	42	45	47	40	43	47	37	41	45	33	39	43
600	MBh†	9.85	9.62	9.38	12.42	12.15	11.89	15.39	15.10	14.78	17.70	17.82	17.81	17.72	18.44	19.06	17.05	18.00	18.78	16.00	17.34	18.15	14.42	16.32	17.76
	T/R	12.00	11.80	11.60	15.20	15.00	14.80	19.00	18.80	18.50	21.90	22.30	22.50	22.00	23.10	24.20	21.10	22.50	23.80	19.80	21.70	23.00	17.70	20.40	22.40
	AMPS*	5.51	5.76	6.03	5.73	6.01	6.29	6.01	6.29	6.59	6.23	6.56	6.90	6.23	6.63	7.05	6.15	6.57	7.00	6.05	6.49	6.92	5.89	6.37	6.85
	HI PR	138	149	160	147	158	170	157	169	181	166	180	193	166	183	200	163	180	197	158	177	194	152	172	191
	LO PR	18	18	18	25	25	25	33	33	33	39	40	42	39	42	45	36	40	43	33	38	41	28	34	39
675	MBh†	10.02	9.79	9.55	12.62	12.35	12.08	15.62	15.32	15.00	17.60	17.80	17.87	17.01	17.96	18.61	16.40	17.40	18.22	15.20	16.62	17.74	13.52	15.45	16.92
	T/R	10.80	10.70	10.50	13.70	13.50	13.40	17.10	16.90	16.70	19.30	19.70	20.00	18.60	19.90	20.80	18.00	19.30	20.40	16.60	18.40	19.80	14.70	17.00	18.90
	AMPS*	5.59	5.85	6.12	5.80	6.07	6.36	6.06	6.33	6.62	6.23	6.56	6.90	6.17	6.58	6.98	6.12	6.52	6.93	6.01	6.44	6.87	5.87	6.32	6.78
	HI PR	136	147	158	144	155	167	154	165	177	161	174	188	158	175	191	156	172	189	151	169	186	145	164	182
	LO PR	18	18	18	25	25	25	33	33	33	38	40	41	36	40	43	34	38	41	30	35	39	25	31	36

N2H324 COOLING		With FS(M,U)2X24 Indoor																															
		Outdoor Ambient Temperature - Degrees F, Dry Bulb																															
		75				85				95				105				115															
		Entering Indoor Temperature - Degrees F, Wet Bulb																															
CFM		72	67	63††	62	57	72	67	63††	62	57	72	67	63††	62	57	72	67	63††	62	57	72	67	63††	62	57							
700	MBh†	26.55	24.11	22.37	22.00	21.50	25.58	23.20	21.51	21.18	20.82	24.57	22.26	20.61	20.32	20.11	23.52	21.27	19.67	19.44	19.36	22.41	20.24	18.69	18.57	18.57							
	S/T‡	0.52	0.71	0.74	0.94	1.00	0.52	0.72	0.75	0.95	1.00	0.53	0.74	0.77	0.97	1.00	0.54	0.75	0.78	0.99	1.00	0.55	0.77	0.80	1.00	1.00							
	AMPS*	7.34	7.28	7.24	7.23	7.22	8.15	8.09	8.04	8.03	8.02	9.06	8.99	8.94	8.93	8.92	10.06	9.98	9.93	9.92	9.91	11.16	11.07	11.00	11.00	11.00							
	HI PR	171	169	167	167	166	200	197	195	195	194	231	228	225	225	225	265	262	259	259	259	302	299	296	296	296							
	LO PR	87	79	73	72	70	88	80	74	73	72	90	81	75	75	74	91	83	77	76	76	92	84	78	78	78							
800	MBh†	27.00	24.52	22.75	22.48	22.30	25.99	23.58	21.86	21.64	21.59	24.95	22.60	20.93	20.83	20.83	23.86	21.58	19.97	20.04	20.05	22.71	20.51	18.95	19.21	19.21							
	S/T‡	0.53	0.75	0.77	0.98	1.00	0.54	0.76	0.79	0.99	1.00	0.55	0.77	0.80	1.00	1.00	0.56	0.79	0.82	1.00	1.00	0.57	0.81	0.84	1.00	1.00							
	AMPS*	7.52	7.45	7.41	7.40	7.40	8.33	8.26	8.21	8.20	8.21	9.23	9.16	9.11	9.11	9.11	10.24	10.16	10.10	10.10	10.10	11.33	11.24	11.17	11.19	11.19							
	HI PR	172	170	168	168	167	200	197	195	195	195	231	228	226	226	226	266	262	260	260	260	303	299	297	297	297							
	LO PR	89	81	75	74	74	90	82	76	75	75	92	83	77	77	77	93	84	78	79	79	94	86	79	81	81							
900	MBh†	27.33	24.82	23.03	22.97	22.97	26.29	23.85	22.12	22.22	22.22	25.22	22.85	21.17	21.43	21.44	24.10	21.81	20.18	20.61	20.61	22.93	20.72	19.15	19.74	19.75							
	S/T‡	0.55	0.78	0.81	1.00	1.00	0.56	0.79	0.82	1.00	1.00	0.57	0.81	0.84	1.00	1.00	0.58	0.83	0.86	1.00	1.00	0.59	0.85	0.88	1.00	1.00							
	AMPS*	7.69	7.62	7.57	7.57	7.57	8.49	8.43	8.38	8.38	8.38	9.40	9.33	9.28	9.29	9.29	10.40	10.32	10.27	10.28	10.28	11.50	11.41	11.35	11.37	11.37							
	HI PR	172	170	168	168	168	201	198	196	196	196	232	229	227	227	227	266	263	260	261	261	304	300	297	298	298							
	LO PR	91	83	76	76	76	92	84	77	78	78	93	85	78	80	80	94	86	79	81	81	95	87	81	83	83							
N2H324 HEATING		With FS(M,U)2X24 Indoor																															
		Outdoor Ambient Temperature - Degrees F, Dry Bulb																															
		-3				7				17				27				37				47				57				67			
		Entering Indoor Temperature - Degrees F, Dry Bulb																															
CFM		65	70	75	65	70	75	65	70	75	65	70	75	65	70	75	65	70	75	65	70	75	65	70	75	65	70	75					
700	MBh†	9.96	9.70	9.40	12.42	12.19	11.93	15.20	14.92	14.65	18.29	18.01	17.71	21.61	21.41	21.10	24.08	24.16	24.24	26.42	26.65	26.78	26.97	28.10	29.06								
	T/R	13.70	13.40	13.10	17.20	17.00	16.80	21.20	21.00	20.70	25.70	25.50	25.30	30.60	30.60	30.40	34.30	34.80	35.20	37.90	38.60	39.20	38.80	40.90	42.80								
	AMPS*	6.57	6.85	7.12	6.87	7.19	7.50	7.20	7.54	7.88	7.62	7.97	8.34	8.06	8.50	8.88	8.41	8.86	9.33	8.79	9.28	9.77	8.85	9.51	10.18								
	HI PR	139	150	161	148	159	171	158	170	182	172	184	196	187	202	215	199	214	230	212	229	245	214	237	259								
	LO PR	17	17	17	24	24	24	32	32	32	40	40	41	50	50	50	57	58	60	63	65	67	65	69	73								
800	MBh†	10.14	9.88	9.59	12.62	12.38	12.13	15.43	15.15	14.88	18.54	18.26	17.96	21.54	21.54	21.36	23.60	23.80	23.92	24.52	25.64	26.17	23.37	25.56	26.68								
	T/R	12.20	11.90	11.70	15.20	15.10	14.90	18.70	18.50	18.40	22.70	22.50	22.30	26.50	26.70	26.80	29.20	29.70	30.20	30.40	32.10	33.20	28.90	32.00	33.90								
	AMPS*	6.66	6.94	7.21	6.93	7.24	7.56	7.23	7.56	7.90	7.61	7.96	8.31	7.96	8.36	8.80	8.25	8.69	9.14	8.37	8.97	9.50	8.19	8.93	9.56								
	HI PR	137	147	159	144	156	167	154	165	177	166	178	190	178	192	206	188	203	218	193	213	231	186	211	233								
	LO PR	17	17	17	24	24	24	31	32	32	40	40	41	49	50	50	54	56	58	57	61	64	53	61	65								
900	MBh†	10.31	10.05	9.76	12.80	12.56	12.31	15.63	15.36	15.08	18.77	18.48	18.18	21.32	21.47	21.48	23.08	23.41	23.62	22.88	24.03	25.00	22.24	23.70	24.91								
	T/R	11.00	10.80	10.60	13.70	13.50	13.40	16.80	16.60	16.50	20.30	20.20	20.00	23.20	23.60	23.80	25.20	25.80	26.30	25.00	26.50	27.90	24.20	26.10	27.80								
	AMPS*	6.76	7.05	7.33	7.01	7.32	7.64	7.28	7.61	7.95	7.65	7.98	8.33	7.92	8.33	8.74	8.16	8.60	9.04	8.12	8.68	9.25	8.04	8.62	9.21								
	HI PR	135	145	156	142	153	164	150	161	173	162	174	186	172	185	199	180	195	210	179	197	217	175	195	215								
	LO PR	17	17	17	24	24	24	31	32	32	40	40	40	47	49	50	52	54	56	51	56	60	49	54	59								

N2H330 COOLING		30 Size With FEM2X30**** Indoor																															
		Outdoor Ambient Temperature - Degrees F, Dry Bulb																															
		75					85					95					105					115											
		Entering Indoor Temperature - Degrees F, Wet Bulb																															
CFM		72	67	63††	62	57	72	67	63††	62	57	72	67	63††	62	57	72	67	63††	62	57	72	67	63††	62	57							
875	MBh†	34.30	31.31	29.13	28.65	27.77	33.02	30.12	28.00	27.56	26.88	31.74	28.92	26.85	26.46	25.97	30.40	27.66	25.65	25.31	25.01	29.00	26.33	24.38	24.13	24.00							
	S/T‡	0.52	0.70	0.73	0.91	1.00	0.52	0.71	0.74	0.93	1.00	0.53	0.72	0.75	0.94	1.00	0.53	0.74	0.76	0.96	1.00	0.54	0.75	0.78	0.98	1.00							
	AMPS*	8.93	8.94	8.96	8.96	8.97	10.05	10.07	10.09	10.09	10.09	11.32	11.33	11.34	11.34	11.34	12.72	12.72	12.72	12.72	12.72	14.25	14.23	14.22	14.21	14.21							
	HI PR	177	174	173	172	171	206	203	201	201	200	238	235	233	232	232	273	270	267	267	266	311	308	305	304	304							
	LO PR	87	79	73	72	69	88	80	74	73	71	90	81	75	74	73	91	83	77	76	75	92	84	78	77	77							
1000	MBh†	34.91	31.88	29.68	29.28	28.82	33.58	30.64	28.51	28.17	27.89	32.26	29.40	27.32	27.07	26.93	30.88	28.10	26.08	25.94	25.93	29.42	26.73	24.78	24.86	24.87							
	S/T‡	0.53	0.73	0.76	0.95	1.00	0.54	0.74	0.77	0.96	1.00	0.54	0.76	0.78	0.98	1.00	0.55	0.77	0.80	1.00	1.00	0.56	0.79	0.82	1.00	1.00							
	AMPS*	9.05	9.06	9.08	9.08	9.09	10.17	10.19	10.21	10.21	10.21	11.45	11.46	11.47	11.46	11.46	12.84	12.85	12.85	12.85	12.84	14.37	14.36	14.35	14.34	14.34							
	HI PR	177	175	173	173	173	206	204	202	201	201	239	236	233	233	233	274	270	268	268	268	312	308	305	306	306							
	LO PR	89	81	75	74	73	90	82	76	75	74	92	83	77	76	76	93	84	78	78	78	94	86	79	80	80							
1125	MBh†	35.38	32.33	30.11	29.85	29.71	34.01	31.05	28.91	28.75	28.73	32.65	29.78	27.69	27.73	27.73	31.24	28.44	26.42	26.68	26.68	29.74	27.05	25.09	25.57	25.58							
	S/T‡	0.54	0.76	0.79	0.98	1.00	0.55	0.77	0.80	1.00	1.00	0.56	0.79	0.81	1.00	1.00	0.57	0.81	0.83	1.00	1.00	0.58	0.83	0.85	1.00	1.00							
	AMPS*	9.17	9.18	9.20	9.20	9.20	10.30	10.31	10.33	10.33	10.33	11.57	11.58	11.59	11.58	11.58	12.97	12.97	12.97	12.97	12.97	14.49	14.48	14.47	14.48	14.48							
	HI PR	178	175	174	173	173	207	204	202	202	202	239	236	234	234	234	274	271	268	269	269	313	309	306	307	307							
	LO PR	91	83	76	76	75	92	84	77	77	77	93	85	78	79	79	94	86	80	81	81	96	87	81	83	83							
N2H330 HEATING		30 Size With FEM2X30**** Indoor																															
		Outdoor Ambient Temperature - Degrees F, Dry Bulb																															
		-3				7				17				27				37				47				57				67			
		Entering Indoor Temperature - Degrees F, Dry Bulb																															
CFM		65	70	75	65	70	75	65	70	75	65	70	75	65	70	75	65	70	75	65	70	75	65	70	75								
875	MBh†	11.46	11.09	10.71	14.39	14.07	13.73	17.50	17.22	16.91	20.88	20.57	20.29	24.62	24.29	23.95	28.18	28.09	27.90	31.36	31.34	31.28	34.55	34.61	34.62								
	T/R	13.00	12.70	12.40	16.40	16.20	15.90	20.10	20.00	19.80	24.20	24.00	23.90	28.70	28.60	28.40	33.20	33.30	33.40	37.20	37.50	37.80	41.20	41.70	42.10								
	AMPS*	8.19	8.55	8.91	8.53	8.93	9.34	8.86	9.31	9.76	9.23	9.70	10.19	9.72	10.21	10.72	10.05	10.62	11.22	10.47	11.06	11.67	10.92	11.56	12.21								
	HI PR	140	151	162	149	160	172	159	171	184	172	184	197	187	200	213	199	214	229	214	229	245	229	245	262								
	LO PR	15	16	16	22	22	22	29	29	29	37	37	37	46	46	46	54	55	56	62	63	64	70	71	73								
1000	MBh†	11.63	11.27	10.89	14.57	14.26	13.92	17.70	17.41	17.12	21.11	20.80	20.51	24.86	24.56	24.23	28.01	28.00	28.00	30.96	31.04	31.05	33.74	33.98	34.11								
	T/R	11.50	11.20	11.00	14.50	14.30	14.10	17.70	17.60	17.40	21.30	21.10	21.00	25.20	25.10	25.00	28.60	28.90	29.10	31.80	32.20	32.50	34.80	35.40	35.90								
	AMPS*	8.23	8.59	8.95	8.52	8.93	9.34	8.80	9.25	9.71	9.13	9.59	10.08	9.55	10.06	10.56	9.80	10.35	10.93	10.14	10.72	11.32	10.49	11.11	11.75								
	HI PR	138	148	159	146	157	169	155	167	179	166	178	190	180	193	206	190	204	219	202	217	232	213	230	246								
	LO PR	15	16	16	22	22	22	29	29	29	37	37	37	46	46	46	53	54	55	60	61	63	66	68	70								
1125	MBh†	11.78	11.43	11.05	14.73	14.42	14.09	17.87	17.59	17.30	21.31	21.00	20.70	25.03	24.77	24.46	27.80	27.87	27.94	30.49	30.68	30.78	31.91	32.94	33.54								
	T/R	10.30	10.10	9.90	13.00	12.80	12.60	15.80	15.70	15.60	19.00	18.90	18.80	22.50	22.40	22.30	25.10	25.40	25.70	27.60	28.10	28.40	29.00	30.30	31.10								
	AMPS*	8.28	8.64	9.01	8.54	8.95	9.37	8.79	9.23	9.69	9.09	9.54	10.02	9.41	9.96	10.47	9.65	10.19	10.74	9.93	10.50	11.09	10.08	10.77	11.44								
	HI PR	136	146	157	143	154	166	151	163	175	162	173	186	173	187	200	182	196	211	193	207	223	198	217	235								
	LO PR	15	15	16	21	22	22	29	29	29	36	37	37	45	46	46	52	53	54	58	60	61	61	65	68								

N2H336 COOLING		36 Size With FEM2X35**** Indoor																															
		Outdoor Ambient Temperature - Degrees F, Dry Bulb																															
		75				85				95				105				115															
		Entering Indoor Temperature - Degrees F, Wet Bulb																															
CFM		72	67	63††	62	57	72	67	63††	62	57	72	67	63††	62	57	72	67	63††	62	57	72	67	63††	62	57							
1050	MBh†	40.55	36.84	34.17	33.63	32.80	39.07	35.46	32.87	32.39	31.78	37.54	34.04	31.52	31.11	30.71	35.95	32.55	30.12	29.79	29.59	34.28	31.00	28.65	28.43	28.42							
	S/T‡	0.51	0.70	0.73	0.92	1.00	0.52	0.71	0.74	0.93	1.00	0.53	0.73	0.75	0.95	1.00	0.53	0.74	0.77	0.96	1.00	0.54	0.76	0.79	1.00	1.00							
	AMPS*	11.26	11.18	11.12	11.11	11.09	12.49	12.40	12.33	12.32	12.31	13.85	13.76	13.69	13.68	13.67	15.36	15.25	15.17	15.16	15.16	17.01	16.89	16.79	16.79	16.79							
	HI PR	174	172	170	170	169	203	200	198	198	197	235	232	229	229	229	269	266	263	263	263	307	303	301	300	300							
	LO PR	83	75	69	68	67	84	76	71	70	68	86	78	72	71	70	87	79	73	73	72	88	80	74	74	74							
1200	MBh†	41.29	37.51	34.80	34.40	34.04	39.75	36.08	33.46	33.15	32.96	38.16	34.60	32.07	31.86	31.84	36.51	33.07	30.62	30.66	30.66	34.79	31.47	29.11	29.42	29.43							
	S/T‡	0.53	0.73	0.76	0.95	1.00	0.54	0.75	0.77	0.97	1.00	0.54	0.76	0.79	1.00	1.00	0.55	0.78	0.80	1.00	1.00	0.56	0.79	0.82	1.00	1.00							
	AMPS*	11.44	11.35	11.29	11.28	11.27	12.66	12.57	12.50	12.50	12.49	14.03	13.93	13.86	13.86	13.86	15.54	15.43	15.35	15.35	15.35	17.18	17.06	16.97	16.99	16.99							
	HI PR	174	172	170	170	170	203	201	199	199	198	235	232	230	230	230	270	267	264	264	264	308	304	301	302	302							
	LO PR	85	77	71	70	70	86	78	72	72	71	87	79	73	73	73	89	81	75	75	75	90	82	76	77	77							
1350	MBh†	41.86	38.04	35.31	35.11	35.09	40.28	36.57	33.93	33.95	33.96	38.65	35.05	32.50	32.78	32.79	36.95	33.48	31.02	31.55	31.56	35.18	31.85	29.48	30.26	30.27							
	S/T‡	0.54	0.76	0.79	1.00	1.00	0.55	0.78	0.81	1.00	1.00	0.56	0.79	0.82	1.00	1.00	0.57	0.81	0.84	1.00	1.00	0.58	0.83	0.86	1.00	1.00							
	AMPS*	11.61	11.52	11.45	11.45	11.45	12.83	12.74	12.67	12.67	12.67	14.20	14.10	14.03	14.04	14.04	15.71	15.60	15.52	15.54	15.54	17.36	17.24	17.14	17.18	17.18							
	HI PR	175	173	171	171	171	204	201	199	199	199	236	233	230	231	231	271	267	265	265	265	308	305	302	303	303							
	LO PR	86	78	72	72	72	88	80	74	74	74	89	81	75	76	76	90	82	76	77	77	91	83	77	79	79							
N2H336 HEATING		36 Size With FEM2X35**** Indoor																															
		Outdoor Ambient Temperature - Degrees F, Dry Bulb																															
		-3				7				17				27				37				47				57				67			
		Entering Indoor Temperature - Degrees F, Dry Bulb																															
CFM		65	70	75	65	70	75	65	70	75	65	70	75	65	70	75	65	70	75	65	70	75	65	70	75								
1050	MBh†	15.24	14.91	14.56	18.79	18.48	18.17	22.78	22.45	22.10	27.24	26.88	26.51	31.58	31.59	31.35	34.86	35.04	35.12	37.45	38.56	38.80	37.85	39.22	40.54								
	T/R	13.70	13.50	13.30	17.00	16.90	16.70	20.80	20.60	20.50	25.00	24.90	24.80	29.20	29.50	29.50	32.40	32.90	33.30	35.00	36.50	37.00	35.40	37.10	38.80								
	AMPS*	9.69	10.10	10.52	10.12	10.58	11.05	10.66	11.13	11.61	11.35	11.84	12.36	11.89	12.50	13.14	12.44	13.08	13.73	12.87	13.72	14.44	12.89	13.79	14.74								
	HI PR	142	153	165	151	163	175	163	175	187	179	191	204	193	207	222	206	221	237	217	237	254	218	239	262								
	LO PR	15	15	16	21	22	22	29	29	29	37	37	37	45	46	47	51	52	54	55	59	60	56	60	63								
1200	MBh†	15.43	15.11	14.76	19.01	18.69	18.37	23.03	22.70	22.34	27.54	27.15	26.79	31.12	31.31	31.40	34.10	34.40	34.62	34.64	36.00	37.29	34.66	36.28	37.68								
	T/R	12.10	12.00	11.80	15.00	14.90	14.80	18.30	18.20	18.00	22.00	21.90	21.80	25.00	25.40	25.70	27.50	28.00	28.50	28.00	29.40	30.80	28.00	29.70	31.20								
	AMPS*	9.73	10.15	10.57	10.12	10.58	11.05	10.63	11.09	11.57	11.30	11.77	12.28	11.69	12.28	12.90	12.16	12.79	13.44	12.22	13.04	13.90	12.19	13.04	13.92								
	HI PR	139	150	162	147	159	171	159	170	182	174	186	198	184	198	213	196	211	226	198	217	238	197	217	238								
	LO PR	15	15	16	21	22	22	29	29	29	37	37	37	43	45	46	49	50	52	49	53	57	49	53	57								
1350	MBh†	15.58	15.28	14.93	19.20	18.87	18.56	23.25	22.91	22.57	27.70	27.40	27.02	30.73	30.96	31.15	32.56	33.78	34.11	32.53	34.02	35.29	32.30	34.05	35.52								
	T/R	10.80	10.70	10.60	13.40	13.30	13.20	16.30	16.30	16.10	19.60	19.60	19.50	21.80	22.20	22.60	23.20	24.30	24.80	23.20	24.50	25.70	23.00	24.50	25.90								
	AMPS*	9.80	10.22	10.64	10.16	10.61	11.08	10.65	11.10	11.57	11.20	11.77	12.26	11.59	12.16	12.76	11.85	12.61	13.25	11.83	12.62	13.42	11.79	12.60	13.43								
	HI PR	137	148	160	144	156	168	155	167	178	168	182	194	178	192	206	185	203	218	184	203	223	183	203	223								
	LO PR	15	15	15	21	22	22	29	29	29	37	37	37	42	43	45	45	49	50	45	49	52	44	48	52								

N2H342 COOLING		42 Size With FEM2X42**** Indoor																																															
		Outdoor Ambient Temperature - Degrees F, Dry Bulb																																															
		75						85						95						105						115																							
		Entering Indoor Temperature - Degrees F, Wet Bulb																																															
CFM		72	67	63††	62	57	72	67	63††	62	57	72	67	63††	62	57	72	67	63††	62	57	72	67	63††	62	57																							
1225	MBh†	49.06	44.73	41.51	40.77	39.49	47.23	43.03	39.91	39.23	38.25	45.38	41.30	38.28	37.66	36.96	43.47	39.52	36.61	36.07	35.65	41.50	37.71	34.91	34.47	34.30																							
	S/T‡	0.50	0.68	0.70	0.88	1.00	0.50	0.69	0.71	0.90	1.00	0.51	0.70	0.73	0.91	1.00	0.51	0.71	0.74	0.93	1.00	0.52	0.73	0.75	0.95	1.00																							
	AMPS*	13.88	13.76	13.66	13.64	13.61	15.26	15.13	15.03	15.01	14.98	16.81	16.67	16.56	16.54	16.51	18.53	18.37	18.26	18.24	18.22	20.43	20.28	20.15	20.13	20.13																							
	HI PR	173	171	169	169	168	202	199	197	197	196	233	230	228	228	227	268	264	262	261	261	305	302	299	298	298																							
	LO PR	87	79	73	72	69	88	80	74	73	71	89	81	75	74	73	91	83	76	76	75	92	84	78	77	77																							
1400	MBh†	49.94	45.57	42.32	41.69	41.04	48.04	43.80	40.66	40.12	39.72	46.12	42.00	38.96	38.53	38.36	44.14	40.16	37.23	36.98	36.97	42.11	38.28	35.47	35.53	35.54																							
	S/T‡	0.51	0.70	0.73	0.92	1.00	0.52	0.72	0.74	0.94	1.00	0.52	0.73	0.76	0.95	1.00	0.53	0.75	0.77	1.00	1.00	0.54	0.76	0.79	1.00	1.00																							
	AMPS*	14.13	14.00	13.90	13.89	13.87	15.50	15.37	15.27	15.26	15.24	17.05	16.91	16.80	16.79	16.78	18.77	18.62	18.50	18.49	18.49	20.67	20.52	20.40	20.40	20.40																							
	HI PR	173	171	169	169	169	202	200	198	197	197	234	231	229	228	228	269	265	262	262	262	306	302	300	300	300																							
	LO PR	89	81	75	74	73	90	82	76	75	74	91	83	77	76	76	92	84	78	78	78	94	86	79	80	80																							
1575	MBh†	50.60	46.18	42.94	42.52	42.34	48.64	44.37	41.23	40.97	40.95	46.67	42.52	39.48	39.52	39.53	44.64	40.63	37.70	38.06	38.07	42.54	38.70	35.90	36.56	36.57																							
	S/T‡	0.53	0.73	0.76	0.95	1.00	0.53	0.75	0.77	1.00	1.00	0.54	0.76	0.79	1.00	1.00	0.55	0.78	0.81	1.00	1.00	0.56	0.80	0.82	1.00	1.00																							
	AMPS*	14.36	14.23	14.14	14.13	14.12	15.74	15.61	15.50	15.50	15.50	17.29	17.15	17.04	17.04	17.04	19.01	18.85	18.74	18.76	18.76	20.91	20.75	20.63	20.67	20.67																							
	HI PR	174	172	170	170	170	203	200	198	198	198	235	231	229	229	229	269	266	263	263	263	307	303	300	301	301																							
	LO PR	90	82	76	76	75	92	84	77	77	77	93	85	78	79	79	94	86	79	80	81	95	87	81	82	82																							
N2H342 HEATING		42 Size With FEM2X42**** Indoor																																															
		Outdoor Ambient Temperature - Degrees F, Dry Bulb																																															
		-3						7						17						27						37						47						57						67					
		Entering Indoor Temperature - Degrees F, Dry Bulb																																															
CFM		65	70	75	65	70	75	65	70	75	65	70	75	65	70	75	65	70	75	65	70	75	65	70	75	65	70	75																					
1225	MBh†	17.96	17.59	17.17	22.16	21.84	21.50	26.73	26.40	26.08	31.92	31.50	31.10	37.62	37.26	36.84	41.97	41.98	41.97	46.51	46.63	46.71	48.41	49.53	50.65																								
	T/R	13.70	13.60	13.40	17.00	16.90	16.80	20.70	20.60	20.50	24.90	24.80	24.70	29.60	29.60	29.50	33.20	33.60	33.90	37.10	37.50	38.00	38.70	40.00	41.40																								
	AMPS*	11.79	12.28	12.77	12.27	12.82	13.39	12.81	13.37	13.98	13.47	14.07	14.69	14.12	14.83	15.58	14.68	15.40	16.16	15.33	16.10	16.91	15.55	16.51	17.54																								
	HI PR	140	151	163	149	160	172	159	171	183	172	185	197	186	200	215	198	213	228	212	228	244	217	236	257																								
	LO PR	15	15	15	21	22	22	29	29	29	37	37	37	45	46	46	52	53	54	59	60	62	62	65	68																								
1400	MBh†	18.21	17.84	17.43	22.41	22.09	21.76	27.04	26.66	26.36	32.29	31.84	31.44	37.48	37.43	37.18	41.37	41.50	41.50	43.78	45.12	45.87	44.28	45.82	47.15																								
	T/R	12.10	12.00	11.80	15.00	14.90	14.80	18.20	18.10	18.10	21.90	21.80	21.70	25.60	25.80	25.90	28.40	28.80	29.00	30.20	31.40	32.30	30.50	32.00	33.20																								
	AMPS*	11.88	12.36	12.86	12.31	12.85	13.42	12.80	13.35	13.95	13.42	13.99	14.61	13.92	14.59	15.30	14.40	15.10	15.83	14.69	15.59	16.46	14.70	15.63	16.59																								
	HI PR	138	148	160	145	157	168	155	166	178	167	179	191	178	191	205	188	202	217	194	213	230	195	214	233																								
	LO PR	15	15	15	21	22	22	28	29	29	36	37	37	44	45	46	50	52	53	54	57	59	54	58	61																								
1575	MBh†	18.42	18.06	17.66	22.64	22.32	21.99	27.31	26.92	26.60	32.62	32.15	31.73	37.04	37.17	37.26	40.64	40.93	41.13	41.06	42.57	43.85	41.20	42.94	44.40																								
	T/R	10.90	10.80	10.60	13.50	13.40	13.30	16.30	16.20	16.20	19.60	19.50	19.40	22.40	22.70	22.90	24.60	25.10	25.40	24.90	26.10	27.20	25.00	26.40	27.60																								
	AMPS*	11.99	12.48	12.97	12.38	12.92	13.48	12.84	13.39	13.97	13.45	13.99	14.59	13.82	14.47	15.17	14.24	14.93	15.65	14.25	15.11	16.00	14.24	15.11	16.02																								
	HI PR	135	146	158	142	154	165	151	162	175	163	175	187	171	185	199	180	194	209	181	198	217	180	198	217																								
	LO PR	15	15	15	21	21	22	28	29	29	36	37	37	43	44	45	49	50	51	49	52	55	49	53	56																								

N2H348 COOLING		48 Size With FEM2X48**** Indoor																								
		Outdoor Ambient Temperature - Degrees F, Dry Bulb																								
		75				85				95				105				115								
		Entering Indoor Temperature - Degrees F, Wet Bulb																								
CFM		72	67	63††	62	57	72	67	63††	62	57	72	67	63††	62	57	72	67	63††	62	57	72	67	63††	62	57
1400	MBh†	54.36	49.43	45.89	45.06	43.70	52.40	47.60	44.17	43.38	42.35	50.36	45.69	42.36	41.63	40.93	48.22	43.69	40.46	39.82	39.43	45.97	41.59	38.48	37.96	37.85
	S/T‡	0.51	0.70	0.73	0.91	1.00	0.52	0.71	0.74	0.93	1.00	0.52	0.72	0.75	0.95	1.00	0.53	0.73	0.76	0.97	1.00	0.54	0.75	0.78	0.99	1.00
	AMPS*	14.99	14.88	14.79	14.78	14.75	16.69	16.57	16.48	16.46	16.44	18.59	18.45	18.34	18.33	18.30	20.67	20.51	20.39	20.37	20.36	22.96	22.77	22.62	22.60	22.59
	HI PR	169	167	165	164	163	198	195	192	192	191	229	226	223	222	222	263	259	256	256	255	300	296	292	292	292
	LO PR	87	79	73	72	69	88	80	74	73	71	89	81	75	74	73	90	82	76	75	75	92	84	77	77	77
1600	MBh†	55.40	50.38	46.79	46.08	45.44	53.36	48.48	45.00	44.37	44.01	51.25	46.50	43.12	42.62	42.51	49.03	44.43	41.16	40.92	40.93	46.70	42.25	39.11	39.26	39.26
	S/T‡	0.53	0.73	0.76	0.95	1.00	0.53	0.74	0.77	0.97	1.00	0.54	0.75	0.78	0.99	1.00	0.55	0.77	0.80	1.00	1.00	0.56	0.79	0.82	1.00	1.00
	AMPS*	15.27	15.15	15.06	15.05	15.04	16.97	16.84	16.75	16.74	16.73	18.87	18.72	18.62	18.61	18.60	20.95	20.79	20.67	20.66	20.66	23.24	23.06	22.90	22.91	22.91
	HI PR	170	167	165	165	165	199	196	193	193	193	230	226	224	223	223	264	260	257	257	257	301	297	293	294	294
	LO PR	89	81	75	74	73	90	82	76	75	74	91	83	77	76	76	92	84	78	78	78	93	85	79	80	80
1800	MBh†	56.19	51.10	47.47	47.01	46.91	54.09	49.14	45.63	45.40	45.41	51.91	47.11	43.70	43.83	43.83	49.63	44.98	41.69	42.17	42.18	47.23	42.76	39.59	40.43	40.44
	S/T‡	0.54	0.76	0.79	0.99	1.00	0.55	0.77	0.80	1.00	1.00	0.56	0.79	0.82	1.00	1.00	0.57	0.81	0.83	1.00	1.00	0.58	0.83	0.86	1.00	1.00
	AMPS*	15.54	15.42	15.33	15.32	15.32	17.24	17.11	17.01	17.01	17.01	19.14	18.99	18.88	18.89	18.89	21.22	21.06	20.94	20.96	20.96	23.52	23.33	23.17	23.22	23.22
	HI PR	170	168	166	166	165	199	196	194	194	194	231	227	224	225	225	265	261	258	258	258	302	298	294	295	295
	LO PR	90	82	76	76	76	91	83	77	77	77	92	84	78	79	79	93	85	79	80	80	95	87	80	82	82

N2H348 HEATING		48 Size With FEM2X48**** Indoor																															
		Outdoor Ambient Temperature - Degrees F, Dry Bulb																															
		-3				7				17				27				37				47				57				67			
		Entering Indoor Temperature - Degrees F, Dry Bulb																															
CFM		65	70	75	65	70	75	65	70	75	65	70	75	65	70	75	65	70	75	65	70	75	65	70	75								
1400	MBh†	19.48	19.02	18.48	24.07	23.66	23.21	29.00	28.61	28.22	34.51	34.07	33.63	40.69	40.20	39.71	47.39	47.02	46.44	53.45	53.34	53.18	57.57	59.54	59.11								
	T/R	13.80	13.60	13.30	17.10	17.00	16.80	20.80	20.70	20.60	24.90	24.80	24.70	29.60	29.50	29.40	34.80	34.80	34.70	39.60	39.90	40.10	42.90	44.90	44.90								
	AMPS*	12.70	13.22	13.74	13.29	13.89	14.49	13.87	14.52	15.20	14.51	15.22	15.94	15.29	16.03	16.80	15.97	16.85	17.81	16.79	17.67	18.58	17.35	18.63	19.54								
	HI PR	139	150	161	147	158	170	157	168	181	169	181	193	183	196	209	197	212	228	213	228	243	224	247	262								
	LO PR	15	15	15	21	21	21	28	28	28	36	36	36	45	45	45	54	55	55	63	64	65	69	73	73								
1600	MBh†	19.77	19.31	18.78	24.36	23.97	23.53	29.33	28.93	28.55	34.92	34.45	34.01	41.16	40.64	40.15	46.98	47.00	46.86	51.57	52.63	52.65	51.52	53.48	55.10								
	T/R	12.20	12.00	11.80	15.10	15.00	14.80	18.30	18.20	18.10	21.90	21.80	21.70	26.00	25.90	25.80	29.90	30.20	30.40	33.00	34.10	34.40	33.00	34.60	36.10								
	AMPS*	12.80	13.32	13.85	13.33	13.93	14.53	13.84	14.49	15.17	14.43	15.12	15.83	15.14	15.85	16.61	15.63	16.44	17.30	16.18	17.19	18.08	16.09	17.21	18.37								
	HI PR	136	147	158	143	155	166	152	163	176	163	175	187	176	189	202	187	201	216	198	216	231	197	216	236								
	LO PR	14	15	15	21	21	21	28	28	28	36	36	36	44	45	45	53	54	55	59	62	63	59	63	66								
1800	MBh†	20.02	19.56	19.05	24.63	24.24	23.81	29.63	29.20	28.84	35.24	34.78	34.34	41.43	40.99	40.52	46.41	46.54	46.61	47.80	49.67	51.03	46.60	49.56	51.42								
	T/R	10.90	10.80	10.60	13.50	13.40	13.30	16.40	16.30	16.20	19.60	19.50	19.40	23.20	23.10	23.10	26.10	26.40	26.70	26.90	28.30	29.40	26.20	28.20	29.60								
	AMPS*	12.93	13.45	13.98	13.41	14.01	14.62	13.88	14.52	15.19	14.42	15.10	15.81	14.93	15.76	16.54	15.45	16.24	17.08	15.56	16.59	17.63	15.37	16.51	17.60								
	HI PR	134	145	156	141	152	163	149	160	172	159	170	183	169	183	196	180	194	208	183	201	219	178	199	218								
	LO PR	14	15	15	21	21	21	28	28	28	35	36	36	44	45	45	51	52	54	53	57	60	51	56	60								

N2H360 COOLING		60 Size With FEM2X60**** Indoor																								
		Outdoor Ambient Temperature - Degrees F, Dry Bulb																								
		75			85			95			105			115												
		Entering Indoor Temperature - Degrees F, Wet Bulb																								
CFM		72	67	63††	62	57	72	67	63††	62	57	72	67	63††	62	57	72	67	63††	62	57	72	67	63††	62	57
1750	MBh†	68.37	62.38	58.00	56.92	55.14	65.77	59.97	55.74	54.73	53.37	63.10	57.50	53.41	52.49	51.54	60.33	54.94	51.00	50.18	49.64	57.44	52.27	48.49	47.82	47.63
	S/T‡	0.52	0.71	0.74	0.93	1.00	0.52	0.72	0.75	0.95	1.00	0.53	0.73	0.76	0.96	1.00	0.53	0.74	0.77	0.98	1.00	0.54	0.76	0.79	1.00	1.00
	AMPS*	19.31	19.04	18.85	18.81	18.74	21.00	20.73	20.53	20.49	20.43	22.89	22.61	22.40	22.36	22.31	24.97	24.68	24.45	24.42	24.39	27.24	26.93	26.70	26.66	26.65
	HI PR	174	172	169	169	168	204	201	198	198	197	236	233	230	229	228	271	267	264	263	263	309	305	301	300	300
	LO PR	87	79	73	72	69	88	80	74	73	71	89	81	75	74	73	91	82	76	75	75	92	84	78	77	77
2000	MBh†	69.40	63.35	58.94	58.03	57.19	66.70	60.85	56.59	55.79	55.31	63.93	58.28	54.17	53.53	53.36	61.06	55.63	51.67	51.33	51.33	58.07	52.86	49.08	49.20	49.20
	S/T‡	0.53	0.74	0.77	0.97	1.00	0.54	0.75	0.78	0.99	1.00	0.54	0.77	0.79	0.99	1.00	0.55	0.78	0.81	1.00	1.00	0.56	0.80	0.83	1.00	1.00
	AMPS*	19.89	19.61	19.41	19.38	19.35	21.58	21.30	21.10	21.07	21.05	23.47	23.18	22.97	22.94	22.94	25.54	25.25	25.02	25.01	25.01	27.82	27.51	27.27	27.29	27.29
	HI PR	175	172	170	170	169	205	202	199	199	198	237	234	231	230	230	272	268	265	265	265	310	306	302	302	302
	LO PR	89	81	75	74	73	90	82	76	75	74	91	83	77	76	76	92	84	78	78	78	94	85	79	80	80
2250	MBh†	70.12	64.03	59.61	59.00	58.84	67.35	61.46	57.18	56.85	56.86	64.49	58.82	54.70	54.81	54.81	61.54	56.10	52.13	52.68	52.69	58.47	53.26	49.47	50.45	50.45
	S/T‡	0.55	0.77	0.80	0.99	1.00	0.55	0.78	0.81	1.00	1.00	0.56	0.80	0.83	1.00	1.00	0.57	0.82	0.85	1.00	1.00	0.58	0.84	0.87	1.00	1.00
	AMPS*	20.45	20.17	19.97	19.96	19.95	22.14	21.86	21.66	21.65	21.65	24.03	23.74	23.53	23.54	23.54	26.11	25.81	25.58	25.62	25.62	28.38	28.07	27.83	27.90	27.90
	HI PR	176	173	171	171	170	206	202	200	200	200	238	234	231	231	231	273	269	265	266	266	311	306	303	304	304
	LO PR	91	83	76	76	76	92	84	77	77	77	93	85	78	79	79	94	86	79	81	81	95	87	81	82	82
N2H360 HEATING		60 Size With FEM2X60**** Indoor																								
		Outdoor Ambient Temperature - Degrees F, Dry Bulb																								
		-3			7			17			27			37			47			57			67			
		Entering Indoor Temperature - Degrees F, Dry Bulb																								
CFM		65	70	75	65	70	75	65	70	75	65	70	75	65	70	75	65	70	75	65	70	75	65	70	75	
1750	MBh†	25.90	25.40	24.88	31.44	31.00	30.54	37.50	37.03	36.61	44.43	43.84	43.29	51.69	51.45	51.07	57.86	58.00	57.87	59.02	61.18	62.57	60.10	62.18	64.02	
	T/R	13.80	13.70	13.50	16.90	16.80	16.70	20.30	20.20	20.10	24.20	24.10	24.00	28.30	28.50	28.50	31.90	32.30	32.50	32.60	34.20	35.40	33.20	34.80	36.20	
	AMPS*	17.04	17.73	18.43	17.68	18.44	19.22	18.40	19.19	20.03	19.27	20.09	20.95	19.96	20.91	21.93	20.72	21.74	22.77	20.78	22.11	23.40	20.84	22.14	23.51	
	HI PR	139	150	161	146	158	170	156	168	180	167	180	192	177	190	204	188	203	217	189	208	227	190	209	228	
	LO PR	13	13	13	18	19	19	25	25	25	32	33	33	40	41	41	47	48	49	48	51	54	49	52	55	
2000	MBh†	26.22	25.77	25.26	31.78	31.39	30.93	37.91	37.43	37.01	45.01	44.42	43.83	51.31	51.19	51.20	54.34	55.99	57.27	54.74	56.81	58.57	53.75	57.17	59.21	
	T/R	12.20	12.10	12.00	14.90	14.80	14.70	17.80	17.80	17.70	21.30	21.20	21.10	24.40	24.60	24.80	26.00	27.00	28.00	26.20	27.50	28.60	25.70	27.60	28.90	
	AMPS*	17.20	17.89	18.59	17.77	18.53	19.31	18.43	19.22	20.05	19.28	20.10	20.92	19.78	20.70	21.68	20.08	21.24	22.42	20.06	21.26	22.51	19.90	21.23	22.50	
	HI PR	136	147	159	143	154	166	152	163	175	161	174	186	169	182	196	174	191	207	174	191	209	171	191	209	
	LO PR	13	13	13	18	19	19	25	25	25	32	33	33	39	40	41	42	45	47	43	46	49	41	46	49	
2250	MBh†	26.55	26.10	25.60	32.12	31.73	31.28	38.31	37.82	37.38	45.39	44.94	44.33	50.82	51.01	51.03	51.29	53.15	54.73	50.57	53.38	55.30	50.04	53.32	55.51	
	T/R	11.00	10.90	10.80	13.30	13.30	13.20	16.00	15.90	15.90	19.00	19.00	18.90	21.40	21.70	21.90	21.60	22.60	23.60	21.30	22.70	23.80	21.10	22.70	23.90	
	AMPS*	17.40	18.09	18.79	17.92	18.68	19.46	18.55	19.32	20.14	19.22	20.17	21.02	19.73	20.65	21.60	19.72	20.84	21.99	19.62	20.81	21.99	19.52	20.75	21.95	
	HI PR	134	145	156	140	151	163	148	160	172	156	169	182	164	177	190	164	180	196	162	179	196	161	179	196	
	LO PR	13	13	13	18	19	19	25	25	25	32	33	33	38	39	40	38	41	44	37	41	44	37	41	44	

COOLING Multiplying Factors for other Indoor Combinations

Indoor Model	Furnace Model	Capac. (MBh)	Power (AMPS)	Indoor Model	Furnace Model	Capac. (MBh)	Power (AMPS)	Indoor Model	Furnace Model	Capac. (MBh)	Power (AMPS)
N2H318											
>FS(M,U)2X18***		1.00	1.00	ED*2X24B**	MV08B15****	1.04	0.89	EP*24F****		0.95	0.98
EB*2X18B**		0.98	0.98	ED*2X24F**		1.02	1.05	EP*24F****	MV12F19****	0.98	0.90
EB*2X18B**	MV08B15****	0.99	0.89	ED*2X24F**	MV12F19****	1.04	0.90	EPP024****		0.88	0.95
EB*2X24B**		1.01	1.01	EHD2X24A**		1.02	1.02	EX*24B****		1.01	1.01
EB*2X24B**	MV08B15****	1.02	0.88	EHD2X24A**	MV08B15****	1.04	0.89	EX*24B****	MV08B15****	1.02	0.92
EB*2X24F**		1.01	1.01	EHD2X24A**	MV12F19****	1.04	0.89	EX*24F****		1.01	1.01
EB*2X24F**	MV12F19****	1.03	0.89	EL*18B****		0.90	0.97	EX*24F****	MV12F19****	1.02	0.92
EBP18****		0.95	0.98	EL*18B****	MV08B15****	0.92	0.89	FEM2X18****		1.02	0.94
EBP24****		1.01	0.99	EL*24B****		0.95	0.98	FEM2X24****		1.03	0.93
EBV24****		1.05	0.91	EL*24B****	MV08B15****	0.98	0.90	FS(M,U)2X24***		1.01	1.01
EBV36****		1.02	0.99	EMA2X24D**		1.02	1.02	FSA2X18****		1.00	0.98
EBX18****		1.01	0.99	EMH24F****		0.95	0.98	FSA2X24****		1.01	0.99
EBX24****		1.01	0.98	EP*18B****		0.90	0.97	FVM2X24****			
ED*2X18B**		0.99	0.99	EP*18B****	MV08B15****	0.92	0.89	FWM18****		0.96	0.94
ED*2X18B**	MV08B15****	1.01	0.91	EP*24B****		0.95	0.98	FWM24****		1.00	0.98
ED*2X24B**		1.02	1.02	EP*24B****	MV08B15****	0.98	0.90				
N2H324											
>FS(M,U)2X24***		1.00	1.00	ED*2X30F**		1.01	1.01	EP*24F****		0.94	1.01
EB*2X24B**		1.00	1.00	ED*2X30F**	*9MPV050	1.03	0.96	EP*24F****	*9MPV050	0.95	0.95
EB*2X24B**	*8MPV050	1.01	0.97	ED*2X30F**	*9MPV075	1.03	0.96	EP*24F****	*9MPV075	0.95	0.95
EB*2X24B**	MV08B15****	1.02	0.94	ED*2X30F**	MV12F19****	1.03	0.95	EP*24F****	MV12F19****	0.96	0.92
EB*2X24F**		1.00	1.00	EHD2X24A**		1.01	1.01	EP*30B****		0.96	1.03
EB*2X24F**	*9MPV050	1.01	0.97	EHD2X24A**	*8MPV050	1.02	0.98	EP*30B****	*8MPV050	0.96	0.96
EB*2X24F**	*9MPV075	1.01	0.95	EHD2X24A**	*9MPV050	1.02	0.98	EP*30B****	MV08B15****	0.96	0.93
EB*2X24F**	MV12F19****	1.03	0.95	EHD2X24A**	*9MPV075	1.02	0.98	EP*30F****		0.96	1.03
EB*2X30B**		1.00	1.00	EHD2X24A**	MV08B15****	1.03	0.95	EP*30F****	*9MPV050	0.96	0.95
EB*2X30B**	*8MPV050	1.02	0.98	EHD2X24A**	MV12F19****	1.03	0.95	EP*30F****	*9MPV075	0.96	0.95
EB*2X30B**	MV08B15****	1.03	0.95	EHD2X24A**	MV16J22****	1.04	0.96	EP*30F****	MV12F19****	0.97	0.94
EB*2X30F**		1.00	1.00	EHD2X24A**	MV20N26****	1.03	0.95	EPP024****		0.87	1.04
EB*2X30F**	*9MPV050	1.02	0.96	EHD2X30A**		1.01	1.01	EPP030****		0.92	1.05
EB*2X30F**	*9MPV075	1.02	0.96	EHD2X30A**	*8MPV050	1.03	0.99	EX*24B****		0.99	1.02
EB*2X30F**	MV12F19****	1.02	0.94	EHD2X30A**	*9MPV050	1.03	0.96	EX*24B****	*8MPV050	1.01	0.97

> Indicates Tested Indoor Model

- continued on next page -

COOLING Multiplying Factors for other Indoor Combinations (continued)

Indoor Model	Furnace Model	Capac. (MBh)	Power (AMPS)	Indoor Model	Furnace Model	Capac. (MBh)	Power (AMPS)	Indoor Model	Furnace Model	Capac. (MBh)	Power (AMPS)
EBP24****		0.99	1.02	EHD2X30A**	*9MPV075	1.02	0.96	EX*24B****	MV08B15****	1.02	0.96
EBP30****		1.00	1.00	EHD2X30A**	MV08B15****	1.03	0.95	EX*24F****		0.99	1.02
EBV24****		1.04	0.97	EHD2X30A**	MV12F19****	1.03	0.95	EX*24F****	*9MPV050	1.01	0.97
EBV36****		1.04	0.97	EHD2X30A**	MV20N26****	1.03	0.95	EX*24F****	*9MPV075	1.01	0.97
EBX18****		0.99	1.02	EL*24B****		0.93	1.00	EX*24F****	MV12F19****	1.01	0.95
EBX24****		1.00	1.03	EL*24B****	*8MPV050	0.95	0.97	FEM2X24****		1.02	0.96
ED*2X24B**		1.01	1.01	EL*24B****	MV08B15****	0.96	0.92	FEM2X30****		1.03	0.96
ED*2X24B**	*8MPV050	1.02	0.98	EL*30B****		0.96	1.03	FS(M,U)2X30***		1.01	1.01
ED*2X24B**	MV08B15****	1.03	0.95	EL*30B****	*8MPV050	0.96	0.96	FSA2X24****		1.00	1.03
ED*2X24F**		1.01	1.01	EL*30B****	MV08B15****	0.96	0.93	FSA2X30****		1.00	1.00
ED*2X24F**	*9MPV050	1.02	0.98	EMA2X24D**		1.01	1.01	FVM2X24****		1.03	0.92
ED*2X24F**	*9MPV075	1.02	0.96	EMH24F****		0.94	1.01	FVM2X36****		1.03	0.92
ED*2X24F**	MV12F19****	1.04	0.96	EMH30F****		0.96	1.03	FWM24****		0.98	1.06
ED*2X30B**		1.01	1.01	EP*24B****		0.94	1.01	FWM30****		1.00	1.03
ED*2X30B**	*8MPV050	1.03	0.99	EP*24B****	*8MPV050	0.95	0.97				
ED*2X30B**	MV08B15****	1.04	0.96	EP*24B****	MV08B15****	0.96	0.92				
N2H330											
>FEM2X30****		1.00	1.00	ED*2X36B**	MV08B15****	1.01	0.99	EHD2X36A**	*8MPV050	1.02	1.02
EB*2X30B**	MV08B15****	1.00	0.98	ED*2X36F**	*8MPV075	1.00	0.98	EHD2X36A**	*8MPV075	1.02	0.98
EB*2X30F**	*8MPV075	0.99	0.98	ED*2X36F**	*9MPV050	0.99	0.99	EHD2X36A**	*8MPV100	1.02	0.98
EB*2X30F**	*9MPV075	0.99	0.99	ED*2X36F**	*9MPV075	0.99	0.99	EHD2X36A**	*8MPV125	1.02	0.96
EB*2X30F**	MV12F19****	1.01	0.98	ED*2X36F**	MV12F19****	1.02	0.98	EHD2X36A**	*9MPV050	1.01	1.00
EB*2X36B**	MV08B15****	1.01	0.99	ED*2X36J**	*8MPV100	1.01	0.98	EHD2X36A**	*9MPV075	1.01	1.00
EB*2X36F**	*8MPV075	1.00	0.98	ED*2X36J**	*8MPV125	1.01	0.98	EHD2X36A**	*9MPV100	1.02	0.98
EB*2X36F**	*9MPV050	0.99	0.99	ED*2X36J**	*9MPV100	1.01	0.99	EHD2X36A**	*9MPV125	1.02	0.98
EB*2X36F**	*9MPV075	0.99	0.99	ED*2X36J**	MV16J22****	1.02	0.96	EHD2X36A**	MV08B15****	1.02	0.98
EB*2X36F**	MV12F19****	1.02	0.98	EHD2X30A**	*8MPV075	1.00	0.98	EHD2X36A**	MV12F19****	1.02	0.96
EB*2X36J**	*8MPV100	1.01	0.98	EHD2X30A**	*8MPV100	1.00	0.98	EHD2X36A**	MV16J22****	1.02	0.96
EB*2X36J**	*8MPV125	1.01	0.98	EHD2X30A**	*8MPV125	1.00	0.96	EHD2X36A**	MV20N26****	1.02	0.96
EB*2X36J**	*9MPV100	1.01	0.99	EHD2X30A**	*9MPV100	0.99	0.98	FEM2X35****		1.01	1.01
EB*2X36J**	MV16J22****	1.02	0.96	EHD2X30A**	*9MPV125	0.99	0.98	FEM2X36****		1.02	1.00
ED*2X30B**	MV08B15****	1.00	0.98	EHD2X30A**	MV08B15****	1.01	1.00	FVM2X24****		0.99	0.96
ED*2X30F**	*8MPV075	0.99	0.98	EHD2X30A**	MV12F19****	1.01	0.98	FVM2X36****		1.00	0.96

> Indicates Tested Indoor Model

- continued on next page -

COOLING Multiplying Factors for other Indoor Combinations (continued)

Indoor Model	Furnace Model	Capac. (MBh)	Power (AMPS)	Indoor Model	Furnace Model	Capac. (MBh)	Power (AMPS)	Indoor Model	Furnace Model	Capac. (MBh)	Power (AMPS)
ED*2X30F**	*9MPV075	0.99	0.99	EHD2X30A**	MV16J22****	1.01	0.98	FVM2X48****		1.02	0.92
ED*2X30F**	MV12F19****	1.01	0.98	EHD2X30A**	MV20N26****	1.01	0.98				
N2H336											
>FEM2X35****		1.00	1.00	ED*2X36J**	*9MPV100	0.99	0.99	EHD2X36A**	MV16J22****	1.03	1.00
EB*2X36F**	MV12F19****	1.00	1.00	ED*2X36J**	MV16J22****	0.98	0.95	EHD2X36A**	MV20N26****	1.03	1.00
EB*2X36J**	*8MPV100	1.00	0.98	ED*2X42F**	*8MPV075	1.00	1.00	EHD2X42A**	*8MPV075	1.02	1.00
EB*2X36J**	*8MPV125	1.00	0.98	ED*2X42F**	MV12F19****	1.02	1.02	EHD2X42A**	*8MPV100	1.03	0.99
EB*2X36J**	*9MPV100	0.99	0.99	ED*2X42J**	*8MPV100	1.01	0.99	EHD2X42A**	*8MPV125	1.03	0.99
EB*2X36J**	MV16J22****	1.01	0.98	ED*2X42J**	*8MPV125	1.01	0.99	EHD2X42A**	*9MPV075	1.01	1.01
EB*2X42F**	*8MPV075	1.00	1.00	ED*2X42J**	*9MPV100	1.00	1.00	EHD2X42A**	*9MPV100	1.02	1.00
EB*2X42F**	MV12F19****	1.02	1.02	ED*2X42J**	MV16J22****	1.02	0.98	EHD2X42A**	*9MPV125	1.03	0.99
EB*2X42J**	*8MPV100	1.01	0.99	ED*2X42L**	*9MPV125	1.01	0.99	EHD2X42A**	MV08B15****	1.03	1.01
EB*2X42J**	*8MPV125	1.01	0.99	EHD2X36A**	*8MPV075	1.01	0.99	EHD2X42A**	MV12F19****	1.03	1.02
EB*2X42J**	*9MPV100	1.00	1.00	EHD2X36A**	*8MPV100	1.02	1.00	EHD2X42A**	MV16J22****	1.03	1.00
EB*2X42J**	MV16J22****	1.02	0.98	EHD2X36A**	*8MPV125	1.02	0.98	EHD2X42A**	MV20N26****	1.03	1.00
EB*2X42L**	*9MPV125	1.01	0.99	EHD2X36A**	*9MPV100	1.02	1.00	FEM2X36****		1.02	1.00
ED*2X36F**	MV12F19****	1.00	1.00	EHD2X36A**	*9MPV125	1.02	1.00	FEM2X42****		1.02	1.00
ED*2X36J**	*8MPV100	1.00	0.98	EHD2X36A**	MV08B15****	1.02	1.02	FVM2X24****		0.98	0.98
ED*2X36J**	*8MPV125	1.00	0.98	EHD2X36A**	MV12F19****	1.03	1.01	FVM2X36****		0.99	0.95
N2H342											
>FEM2X42****		1.00	1.00	ED*2X42J**	*9MPV100	0.98	0.98	EHD2X42A**	MV16J22****	1.02	0.99
EB*2X42J**	*8MPV100	0.98	0.98	ED*2X42J**	MV16J22****	0.99	0.97	EHD2X42A**	MV20N26****	1.00	0.96
EB*2X42J**	*8MPV125	0.98	0.96	ED*2X42L**	*9MPV125	0.98	0.98	EHD2X48A**	*8MPV075	1.00	1.00
EB*2X42J**	*9MPV100	0.98	0.98	ED*2X48F**	*8MPV075	0.99	0.99	EHD2X48A**	*8MPV100	1.00	0.96
EB*2X42J**	MV16J22****	0.99	0.97	ED*2X48J**	*8MPV100	1.00	0.98	EHD2X48A**	*8MPV125	1.00	0.96
EB*2X42L**	*9MPV125	0.98	0.98	ED*2X48J**	*8MPV125	1.00	0.96	EHD2X48A**	*9MPV100	1.00	0.98
EB*2X48F**	*8MPV075	0.99	0.99	ED*2X48J**	*9MPV100	0.99	0.99	EHD2X48A**	*9MPV125	1.00	0.98
EB*2X48J**	*8MPV100	1.00	0.98	ED*2X48J**	MV16J22****	1.01	0.98	EHD2X48A**	MV16J22****	1.01	0.98
EB*2X48J**	*8MPV125	1.00	0.96	ED*2X48L**	*9MPV125	0.99	0.97	EHD2X48A**	MV20N26****	1.01	0.98
EB*2X48J**	*9MPV100	0.99	0.99	EHD2X42A**	*8MPV075	0.99	0.99	FEM2X48****		1.02	0.99
EB*2X48J**	MV16J22****	1.01	0.98	EHD2X42A**	*8MPV100	1.00	0.98	FVM2X36****		0.96	0.95
EB*2X48L**	*9MPV125	0.99	0.97	EHD2X42A**	*8MPV125	1.00	0.96	FVM2X48****		1.01	0.98
ED*2X42J**	*8MPV100	0.98	0.98	EHD2X42A**	*9MPV100	1.00	0.98				

> Indicates Tested Indoor Model

- continued on next page -

COOLING Multiplying Factors for other Indoor Combinations (continued)											
Indoor Model	Furnace Model	Capac. (MBh)	Power (AMPS)	Indoor Model	Furnace Model	Capac. (MBh)	Power (AMPS)	Indoor Model	Furnace Model	Capac. (MBh)	Power (AMPS)
ED*2X42J**	*8MPV125	0.98	0.96	EHD2X42A**	*9MPV125	1.00	0.98				
N2H348											
>FEM2X48****		1.00	1.00	ED*2X48J**	*8MPV125	0.97	0.97	EHD2X48A**	MV16J22****	0.99	0.95
EB*2X48J**	*8MPV100	0.97	0.97	ED*2X48J**	MV16J22****	0.98	0.94	EHD2X48A**	MV20N26****	1.00	0.96
EB*2X48J**	*8MPV125	0.97	0.97	ED*2X48L**	*9MPV125	0.97	0.97	EHD2X60A**	*8MPV100	1.01	0.97
EB*2X48J**	MV16J22****	0.99	0.97	ED*2X60J**	*8MPV100	1.00	0.98	EHD2X60A**	*8MPV125	1.01	0.97
EB*2X48L**	*9MPV125	0.97	0.97	ED*2X60J**	*8MPV125	1.00	0.96	EHD2X60A**	*9MPV100	1.00	0.98
EB*2X60J**	*8MPV100	1.00	0.98	ED*2X60J**	*9MPV100	0.99	0.99	EHD2X60A**	*9MPV125	1.00	0.98
EB*2X60J**	*8MPV125	1.00	0.96	ED*2X60J**	MV16J22****	1.00	0.96	EHD2X60A**	MV16J22****	1.01	0.91
EB*2X60J**	*9MPV100	0.99	0.99	ED*2X60L**	*9MPV125	0.99	0.97	EHD2X60A**	MV20N26****	1.02	0.98
EB*2X60J**	MV16J22****	1.00	0.96	EHD2X48A**	*8MPV100	0.98	0.98	FEM2X60****		1.02	0.98
EB*2X60L**	*9MPV125	0.99	0.97	EHD2X48A**	*8MPV125	0.98	0.96	FVM2X48****		0.99	0.95
ED*2X48J**	*8MPV100	0.97	0.97	EHD2X48A**	*9MPV125	0.98	0.98	FVM2X60****		1.01	0.91
N2H360											
>FEM2X60****		1.00	1.00	EHD2X60A**	MV20N26****	1.01	1.01	FVM2X60****		1.00	1.00
EHD2X60A**	MV16J22****	1.01	1.01								

> Indicates Tested Indoor Model

HEATING Multiplying Factors for other Indoor Combinations

Indoor Model	Furnace Model	Capac. (MBh)	Power (AMPS)	Indoor Model	Furnace Model	Capac. (MBh)	Power (AMPS)	Indoor Model	Furnace Model	Capac. (MBh)	Power (AMPS)
N2H318											
>FS(M,U)2X18**		1.00	1.00	ED*2X24B**	MV08B15****	0.86	0.83	EP*24F****		1.00	1.04
EB*2X18B**		1.00	1.02	ED*2X24F**		0.87	0.93	EP*24F****	MV12F19****	0.99	0.95
EB*2X18B**	MV08B15****	1.00	0.94	ED*2X24F**	MV12F19****	0.85	0.83	EPP024****		1.11	1.21
EB*2X24B**		0.87	0.92	EHD2X24A**		0.82	0.89	EX*24B****		0.76	0.89
EB*2X24B**	MV08B15****	0.85	0.82	EHD2X24A**	MV08B15****	0.83	0.82	EX*24B****	MV08B15****	0.75	0.80
EB*2X24F**		0.87	0.92	EHD2X24A**	MV12F19****	0.84	0.83	EX*24F****		0.76	0.89
EB*2X24F**	MV12F19****	0.84	0.82	EL*18B****		1.10	1.18	EX*24F****	MV12F19****	0.76	0.80
EBP18****		1.14	1.11	EL*18B****	MV08B15****	1.08	1.09	FEM2X18****		0.97	0.91
EBP24****		0.99	0.98	EL*24B****		1.00	1.04	FEM2X24****		0.86	0.85
EBV24****		0.77	0.79	EL*24B****	MV08B15****	0.98	0.94	FS(M,U)2X24*		0.89	0.95
EBV36****		0.74	0.85	EMA2X24D**		0.89	0.92	FSA2X18****		1.00	1.00
EBX18****		0.99	0.98	EMH24F****		1.00	1.04	FSA2X24****		0.87	0.93
EBX24****		0.88	0.93	EP*18B****		1.11	1.19	FVM2X24****			
ED*2X18B**		1.01	1.03	EP*18B****	MV08B15****	1.08	1.09	FWM18****		1.14	1.09
ED*2X18B**	MV08B15****	1.01	0.95	EP*24B****		1.00	1.04	FWM24****		1.00	1.00
ED*2X24B**		0.87	0.93	EP*24B****	MV08B15****	0.98	0.94				
N2H324											
>FS(M,U)2X24**		1.00	1.00	ED*2X30F**		0.87	0.94	EP*24F****		1.03	1.07
EB*2X24B**		0.99	0.98	ED*2X30F**	*9MPV050	0.86	0.87	EP*24F****	*9MPV050	1.01	1.02
EB*2X24B**	*8MPV050	0.97	0.93	ED*2X30F**	*9MPV075	0.87	0.87	EP*24F****	*9MPV075	1.01	1.02
EB*2X24B**	MV08B15****	0.97	0.90	ED*2X30F**	MV12F19****	0.88	0.86	EP*24F****	MV12F19****	1.00	0.98
EB*2X24F**		0.99	0.98	EHD2X24A**		0.97	0.96	EP*30B****		1.02	1.04
EB*2X24F**	*9MPV050	0.97	0.92	EHD2X24A**	*8MPV050	0.97	0.92	EP*30B****	*8MPV050	1.00	0.99
EB*2X24F**	*9MPV075	0.98	0.93	EHD2X24A**	*9MPV050	0.96	0.92	EP*30B****	MV08B15****	0.99	0.96
EB*2X24F**	MV12F19****	0.97	0.88	EHD2X24A**	*9MPV075	0.97	0.92	EP*30F****		1.02	1.04
EB*2X30B**		0.87	0.93	EHD2X24A**	MV08B15****	0.95	0.88	EP*30F****	*9MPV050	1.00	0.98
EB*2X30B**	*8MPV050	0.87	0.88	EHD2X24A**	MV12F19****	0.96	0.88	EP*30F****	*9MPV075	1.00	0.98
EB*2X30B**	MV08B15****	0.86	0.85	EHD2X24A**	MV16J22****	0.94	0.86	EP*30F****	MV12F19****	0.99	0.95

> Indicates Tested Indoor Model

- continued on next page -

HEATING Multiplying Factors for other Indoor Combinations (continued)

Indoor Model	Furnace Model	Capac. (MBh)	Power (AMPS)	Indoor Model	Furnace Model	Capac. (MBh)	Power (AMPS)	Indoor Model	Furnace Model	Capac. (MBh)	Power (AMPS)
EB*2X30F**		0.87	0.93	EHD2X24A**	MV20N26****	0.96	0.88	EPP024****		1.02	1.18
EB*2X30F**	*9MPV050	0.85	0.86	EHD2X30A**		0.85	0.92	EPP030****		1.03	1.10
EB*2X30F**	*9MPV075	0.86	0.86	EHD2X30A**	*8MPV050	0.83	0.87	EX*24B****		0.88	0.95
EB*2X30F**	MV12F19****	0.87	0.85	EHD2X30A**	*9MPV050	0.84	0.86	EX*24B****	*8MPV050	0.88	0.91
EBP24****		1.04	1.02	EHD2X30A**	*9MPV075	0.86	0.87	EX*24B****	MV08B15****	0.86	0.86
EBP30****		1.00	1.00	EHD2X30A**	MV08B15****	0.84	0.84	EX*24F****		0.88	0.95
EBV24****		0.93	0.89	EHD2X30A**	MV12F19****	0.83	0.83	EX*24F****	*9MPV050	0.87	0.91
EBV36****		0.83	0.86	EHD2X30A**	MV20N26****	0.82	0.82	EX*24F****	*9MPV075	0.88	0.91
EBX18****		1.04	1.02	EL*24B****		1.03	1.08	EX*24F****	MV12F19****	0.88	0.87
EBX24****		1.00	1.00	EL*24B****	*8MPV050	1.02	1.02	FEM2X24****		0.98	0.93
ED*2X24B**		1.00	0.99	EL*24B****	MV08B15****	1.00	0.99	FEM2X30****		0.93	0.90
ED*2X24B**	*8MPV050	0.98	0.93	EL*30B****		1.02	1.04	FS(M,U)2X30*		0.95	0.97
ED*2X24B**	MV08B15****	0.98	0.91	EL*30B****	*8MPV050	1.00	0.99	FSA2X24****		1.00	1.00
ED*2X24F**		1.00	0.99	EL*30B****	MV08B15****	0.99	0.96	FSA2X30****		0.99	0.99
ED*2X24F**	*9MPV050	0.98	0.93	EMA2X24D**		1.00	0.96	FVM2X24****		0.95	0.88
ED*2X24F**	*9MPV075	0.99	0.93	EMH24F****		1.03	1.07	FVM2X36****		0.87	0.86
ED*2X24F**	MV12F19****	0.97	0.89	EMH30F****		1.02	1.04	FWM24****		1.04	1.03
ED*2X30B**		0.87	0.94	EP*24B****		1.03	1.07	FWM30****		1.00	1.00
ED*2X30B**	*8MPV050	0.87	0.89	EP*24B****	*8MPV050	1.02	1.02				
ED*2X30B**	MV08B15****	0.87	0.86	EP*24B****	MV08B15****	1.00	0.99				

N2H330

>FEM2X30****		1.00	1.00	ED*2X36B**	MV08B15****	0.97	0.97	EHD2X36A**	*8MPV050	0.96	0.99
EB*2X30B**	MV08B15****	0.99	0.99	ED*2X36F**	*8MPV075	0.98	0.98	EHD2X36A**	*8MPV075	0.96	0.96
EB*2X30F**	*8MPV075	0.99	0.99	ED*2X36F**	*9MPV050	0.99	1.01	EHD2X36A**	*8MPV100	0.95	0.94
EB*2X30F**	*9MPV075	0.99	1.02	ED*2X36F**	*9MPV075	0.99	1.01	EHD2X36A**	*8MPV125	0.95	0.93
EB*2X30F**	MV12F19****	0.98	0.96	ED*2X36F**	MV12F19****	0.96	0.95	EHD2X36A**	*9MPV050	0.96	0.98
EB*2X36B**	MV08B15****	0.97	0.97	ED*2X36J**	*8MPV100	0.97	0.96	EHD2X36A**	*9MPV075	0.96	0.98
EB*2X36F**	*8MPV075	0.98	0.98	ED*2X36J**	*8MPV125	0.96	0.95	EHD2X36A**	*9MPV100	0.95	0.95
EB*2X36F**	*9MPV050	0.99	1.01	ED*2X36J**	*9MPV100	0.97	0.97	EHD2X36A**	*9MPV125	0.95	0.94

> Indicates Tested Indoor Model

HEATING Multiplying Factors for other Indoor Combinations (continued)

Indoor Model	Furnace Model	Capac. (MBh)	Power (AMPS)	Indoor Model	Furnace Model	Capac. (MBh)	Power (AMPS)	Indoor Model	Furnace Model	Capac. (MBh)	Power (AMPS)
EB*2X36F**	*9MPV075	0.98	1.00	ED*2X36J**	MV16J22****	0.96	0.93	EHD2X36A**	MV08B15****	0.94	0.93
EB*2X36F**	MV12F19****	0.96	0.95	EHD2X30A**	*8MPV075	0.98	0.99	EHD2X36A**	MV12F19****	0.94	0.92
EB*2X36J**	*8MPV100	0.97	0.96	EHD2X30A**	*8MPV100	0.98	0.98	EHD2X36A**	MV16J22****	0.94	0.91
EB*2X36J**	*8MPV125	0.96	0.95	EHD2X30A**	*8MPV125	0.98	0.98	EHD2X36A**	MV20N26****	0.94	0.90
EB*2X36J**	*9MPV100	0.97	0.97	EHD2X30A**	*9MPV100	0.98	0.99	FEM2X35****		0.98	1.00
EB*2X36J**	MV16J22****	0.96	0.93	EHD2X30A**	*9MPV125	0.98	0.99	FEM2X36****		0.94	0.97
ED*2X30B**	MV08B15****	0.99	0.99	EHD2X30A**	MV08B15****	0.98	0.98	FVM2X24****		1.00	0.98
ED*2X30F**	*8MPV075	0.99	0.99	EHD2X30A**	MV12F19****	0.97	0.96	FVM2X36****		0.97	0.97
ED*2X30F**	*9MPV075	0.99	1.02	EHD2X30A**	MV16J22****	0.97	0.96	FVM2X48****		0.84	0.89
ED*2X30F**	MV12F19****	0.97	0.96	EHD2X30A**	MV20N26****	0.97	0.95				

N2H336

>FEM2X35****		1.00	1.00	ED*2X36J**	*9MPV100	1.01	1.01	EHD2X36A**	MV16J22****	0.88	0.90
EB*2X36F**	MV12F19****	0.99	1.00	ED*2X36J**	MV16J22****	0.98	0.96	EHD2X36A**	MV20N26****	0.87	0.89
EB*2X36J**	*8MPV100	0.99	0.99	ED*2X42F**	*8MPV075	0.99	0.99	EHD2X42A**	*8MPV075	0.89	0.93
EB*2X36J**	*8MPV125	1.00	0.99	ED*2X42F**	MV12F19****	0.94	0.95	EHD2X42A**	*8MPV100	0.86	0.90
EB*2X36J**	*9MPV100	1.01	1.01	ED*2X42J**	*8MPV100	0.96	0.96	EHD2X42A**	*8MPV125	0.87	0.90
EB*2X36J**	MV16J22****	0.98	0.96	ED*2X42J**	*8MPV125	0.96	0.96	EHD2X42A**	*9MPV075	0.92	0.96
EB*2X42F**	*8MPV075	0.99	0.99	ED*2X42J**	*9MPV100	0.97	0.98	EHD2X42A**	*9MPV100	0.87	0.91
EB*2X42F**	MV12F19****	0.94	0.95	ED*2X42J**	MV16J22****	0.93	0.93	EHD2X42A**	*9MPV125	0.87	0.91
EB*2X42J**	*8MPV100	0.96	0.96	ED*2X42L**	*9MPV125	0.97	0.97	EHD2X42A**	MV08B15****	0.85	0.91
EB*2X42J**	*8MPV125	0.96	0.96	EHD2X36A**	*8MPV075	0.94	0.96	EHD2X42A**	MV12F19****	0.83	0.89
EB*2X42J**	*9MPV100	0.97	0.98	EHD2X36A**	*8MPV100	0.91	0.93	EHD2X42A**	MV16J22****	0.83	0.87
EB*2X42J**	MV16J22****	0.93	0.93	EHD2X36A**	*8MPV125	0.92	0.93	EHD2X42A**	MV20N26****	0.83	0.87
EB*2X42L**	*9MPV125	0.97	0.97	EHD2X36A**	*9MPV100	0.92	0.94	FEM2X36****		0.89	0.93
ED*2X36F**	MV12F19****	0.99	1.00	EHD2X36A**	*9MPV125	0.92	0.93	FEM2X42****		0.88	0.92
ED*2X36J**	*8MPV100	0.99	0.99	EHD2X36A**	MV08B15****	0.89	0.94	FVM2X24****		1.05	1.01
ED*2X36J**	*8MPV125	1.00	0.99	EHD2X36A**	MV12F19****	0.09	0.09	FVM2X36****		1.01	1.00

N2H342

>FEM2X42****		1.00	1.00	ED*2X42J**	*9MPV100	1.02	1.03	EHD2X42A**	MV16J22****	0.98	0.95
--------------	--	------	------	------------	----------	------	------	------------	-------------	------	------

> Indicates Tested Indoor Model

HEATING Multiplying Factors for other Indoor Combinations (continued)

Indoor Model	Furnace Model	Capac. (MBh)	Power (AMPS)	Indoor Model	Furnace Model	Capac. (MBh)	Power (AMPS)	Indoor Model	Furnace Model	Capac. (MBh)	Power (AMPS)
EB*2X42J**	*8MPV100	1.02	1.02	ED*2X42J**	MV16J22****	1.01	0.99	EHD2X42A**	MV20N26****	0.99	0.95
EB*2X42J**	*8MPV125	1.01	1.01	ED*2X42L**	*9MPV125	1.02	1.03	EHD2X48A**	*8MPV075	1.00	1.00
EB*2X42J**	*9MPV100	1.02	1.03	ED*2X48F**	*8MPV075	0.95	0.97	EHD2X48A**	*8MPV100	0.99	0.97
EB*2X42J**	MV16J22****	1.01	0.99	ED*2X48J**	*8MPV100	0.96	0.96	EHD2X48A**	*8MPV125	0.99	0.97
EB*2X42L**	*9MPV125	1.02	1.03	ED*2X48J**	*8MPV125	0.96	0.96	EHD2X48A**	*9MPV100	0.99	0.98
EB*2X48F**	*8MPV075	0.95	0.97	ED*2X48J**	*9MPV100	0.98	0.98	EHD2X48A**	*9MPV125	0.99	0.97
EB*2X48J**	*8MPV100	0.96	0.96	ED*2X48J**	MV16J22****	0.94	0.93	EHD2X48A**	MV16J22****	0.98	0.94
EB*2X48J**	*8MPV125	0.96	0.96	ED*2X48L**	*9MPV125	0.98	0.97	EHD2X48A**	MV20N26****	0.98	0.94
EB*2X48J**	*9MPV100	0.98	0.98	EHD2X42A**	*8MPV075	1.00	1.00	FEM2X48****		0.93	0.93
EB*2X48J**	MV16J22****	0.94	0.93	EHD2X42A**	*8MPV100	1.00	0.98	FVM2X36****		1.02	1.05
EB*2X48L**	*9MPV125	0.98	0.97	EHD2X42A**	*8MPV125	1.00	0.98	FVM2X48****		0.91	0.93
ED*2X42J**	*8MPV100	1.02	1.02	EHD2X42A**	*9MPV100	1.00	0.99				
ED*2X42J**	*8MPV125	1.01	1.01	EHD2X42A**	*9MPV125	1.00	0.99				
N2H348											
>FEM2X48****		1.00	1.00	ED*2X48J**	*8MPV125	1.01	1.05	EHD2X48A**	MV16J22****	1.00	1.02
EB*2X48J**	*8MPV100	1.01	1.05	ED*2X48J**	MV16J22****	1.00	1.03	EHD2X48A**	MV20N26****	1.01	1.00
EB*2X48J**	*8MPV125	1.01	1.05	ED*2X48L**	*9MPV125	1.01	1.06	EHD2X60A**	*8MPV100	0.98	1.00
EB*2X48J**	MV16J22****	1.01	1.01	ED*2X60J**	*8MPV100	0.91	0.99	EHD2X60A**	*8MPV125	0.98	1.00
EB*2X48L**	*9MPV125	1.01	1.06	ED*2X60J**	*8MPV125	0.91	0.98	EHD2X60A**	*9MPV100	0.99	1.02
EB*2X60J**	*8MPV100	0.91	0.99	ED*2X60J**	*9MPV100	0.92	1.00	EHD2X60A**	*9MPV125	0.99	1.02
EB*2X60J**	*8MPV125	0.91	0.98	ED*2X60J**	MV16J22****	0.92	0.96	EHD2X60A**	MV16J22****	0.98	0.98
EB*2X60J**	*9MPV100	0.92	1.00	ED*2X60L**	*9MPV125	0.94	1.00	EHD2X60A**	MV20N26****	0.94	0.96
EB*2X60J**	MV16J22****	0.92	0.96	EHD2X48A**	*8MPV100	1.01	1.05	FEM2X60****		0.89	0.93
EB*2X60L**	*9MPV125	0.94	1.00	EHD2X48A**	*8MPV125	1.01	1.04	FVM2X48****		0.99	1.01
ED*2X48J**	*8MPV100	1.01	1.05	EHD2X48A**	*9MPV125	1.01	1.06	FVM2X60****		0.97	0.97
N2H360											
>FEM2X60****		1.00	1.00	EHD2X60A**	MV20N26****	1.01	1.00	FVM2X60****		1.00	0.99
EHD2X60A**	MV16J22****	1.01	1.00								

> Indicates Tested Indoor Model

NOTE: This illustration is for reference only. Your unit may differ in appearance or may not include all components shown. Please refer to Parts List for exact parts listing.

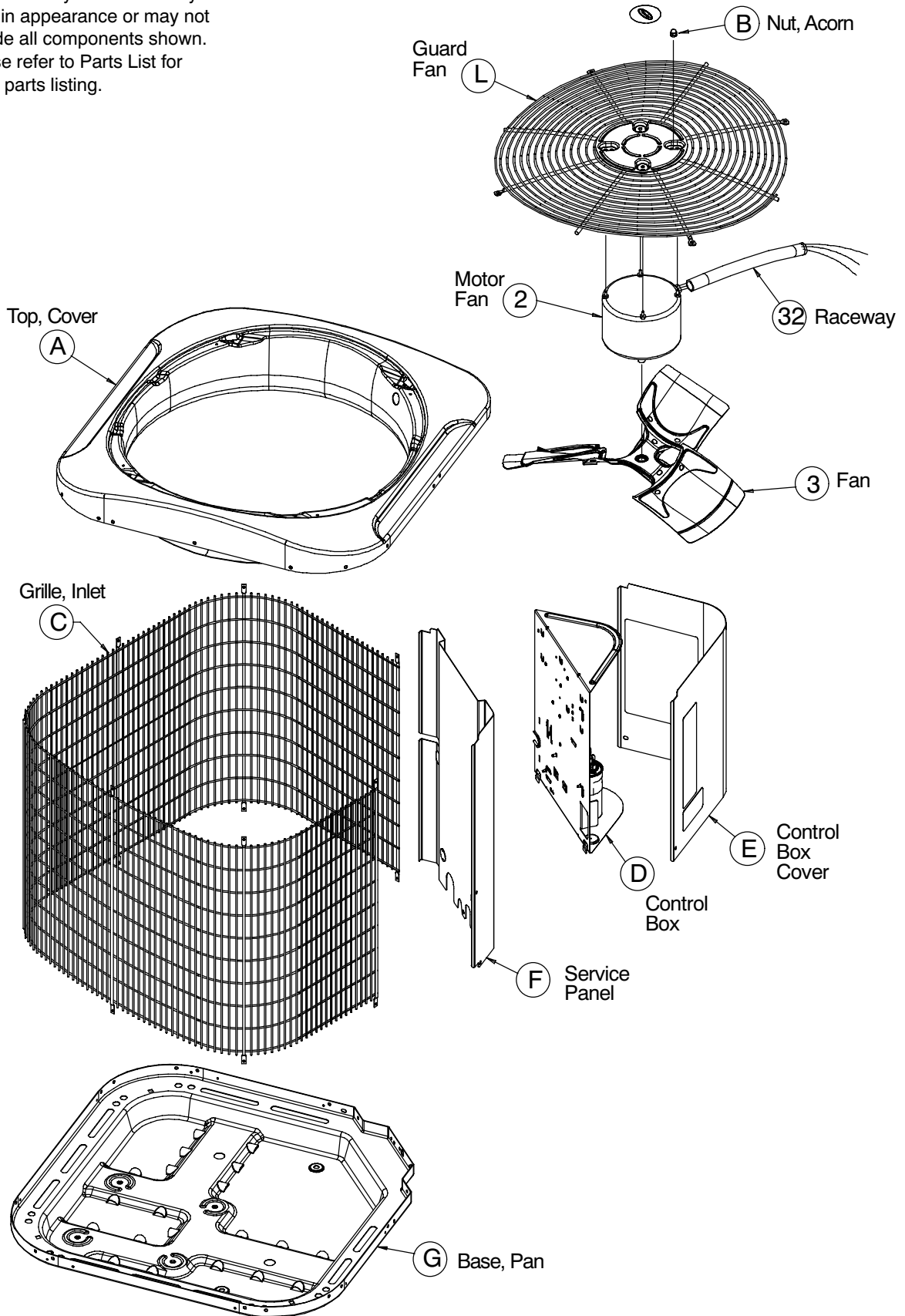

NOTE: This illustration is for reference only. Your unit may differ in appearance or may not include all components shown. Please refer to Parts List for exact parts listing.

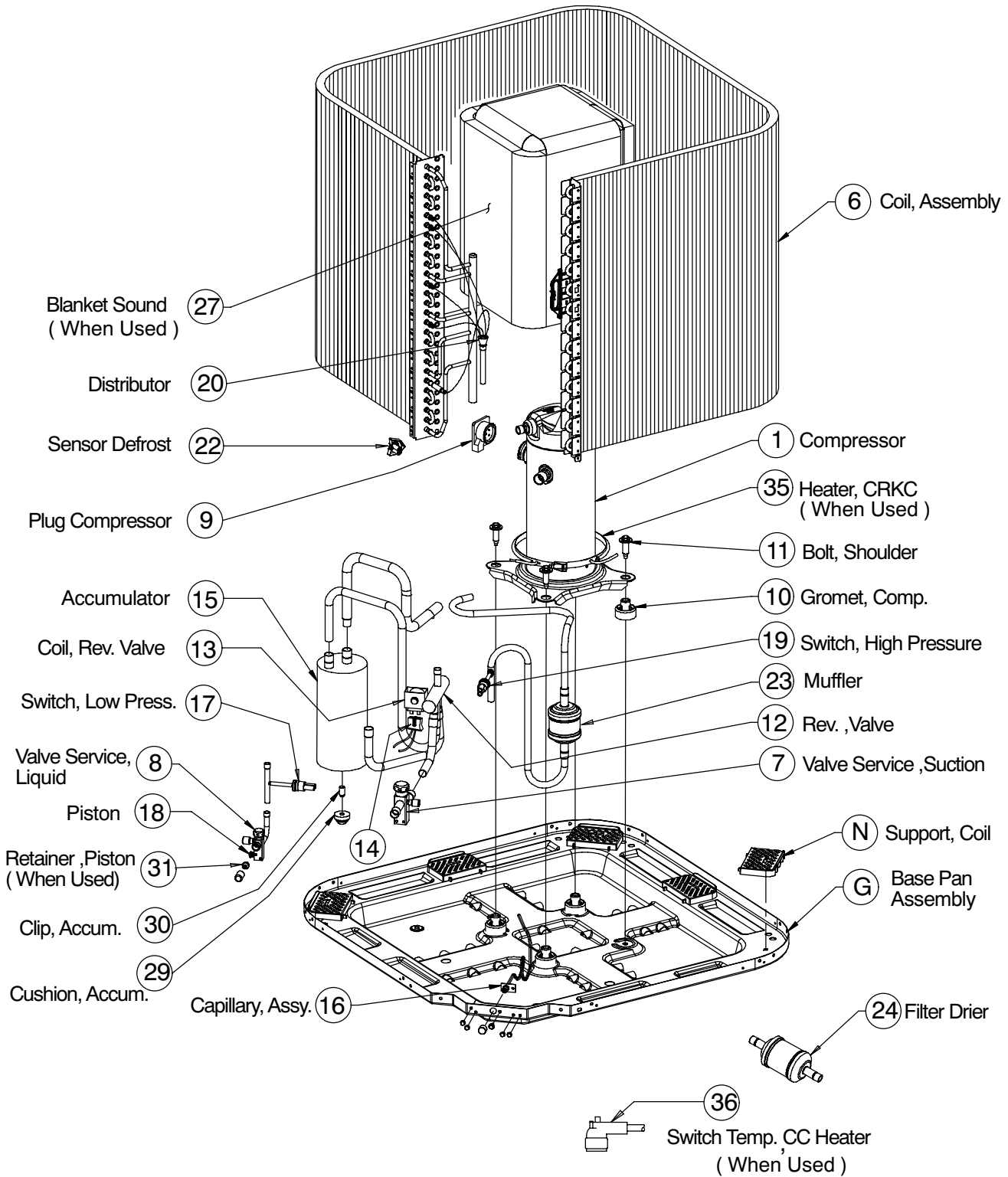

NOTE: This illustration is for reference only. Your unit may differ in appearance or may not include all components shown. Please refer to Parts List for exact parts listing.

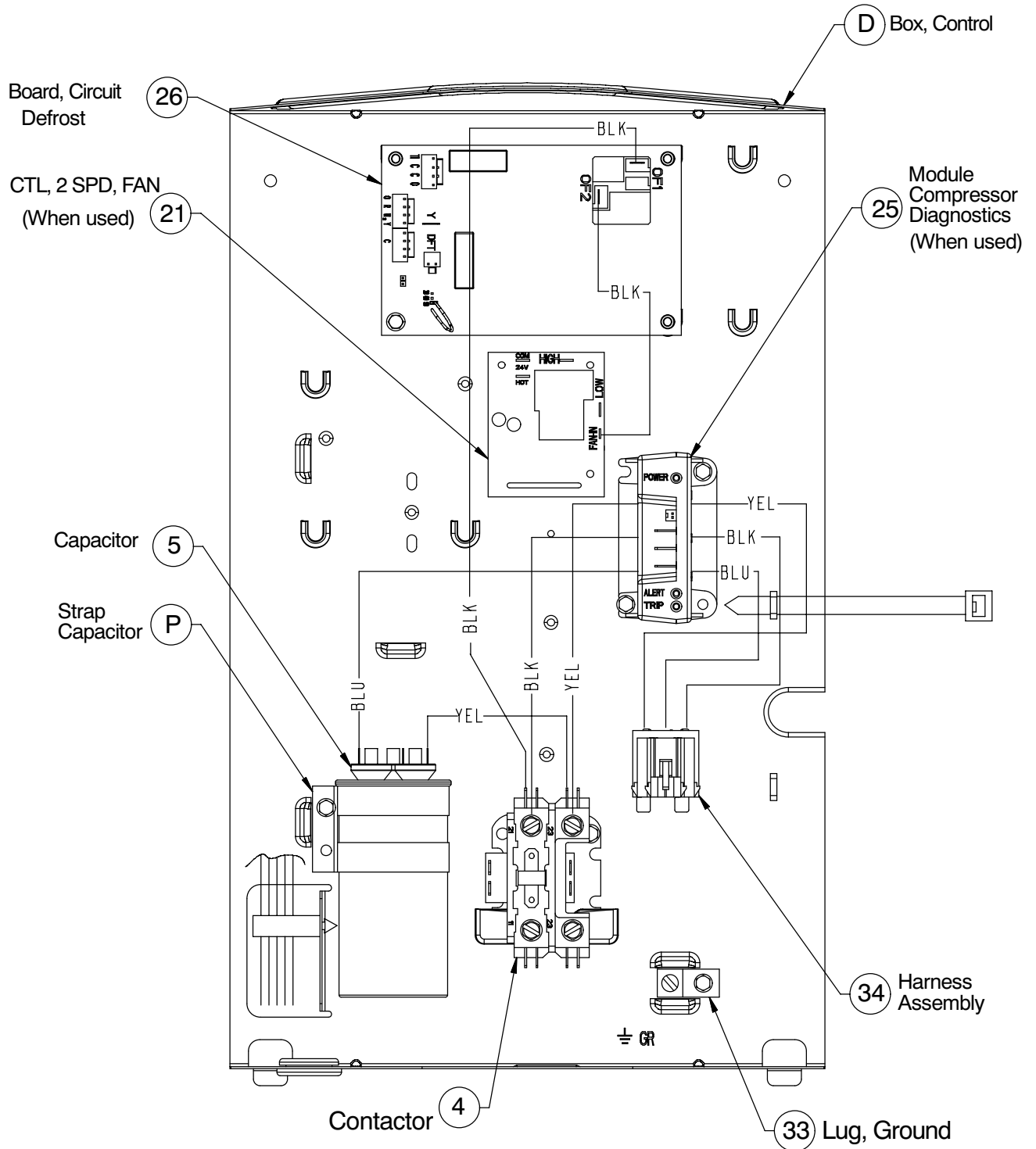

N2H3 PARTS LIST																
KEY NO.	DESCRIPTION	PART NO.	N2H318AKA100	N2H318GKA100	N2H324AKA100	N2H324GKA100	N2H330AKB100	N2H330GKB100	N2H336AKB100	N2H336GKB100	N2H342AKB100	N2H342GKB100	N2H348AKB100	N2H348GKB100	N2H360AKB100	N2H360GKB100
1	Compressor	ZR16K4PFV130	1	1	-	-	-	-	-	-	-	-	-	-	-	-
1		ZR22K4PFV130	-	-	1	1	-	-	-	-	-	-	-	-	-	-
1		ZR28K3PFV130	-	-	-	-	1	1	-	-	-	-	-	-	-	-
1		ZR34K3PFV130	-	-	-	-	-	-	-	1	1	-	-	-	-	-
1		ZR40K3PFV130	-	-	-	-	-	-	-	-	-	-	1	1	-	-
1		ZR45K3PFV135	-	-	-	-	-	-	-	-	-	-	-	-	1	1
1		ZR57K3PFV130	-	-	-	-	-	-	1	1	-	-	-	-	-	-
2	Motor, Condenser Fan	1173716	1	1	-	-	-	-	-	-	-	-	-	-	-	-
2		1173646	-	-	1	1	1	1	-	-	-	-	-	-	-	-
2		1173717	-	-	-	-	-	-	-	-	1	1	-	-	-	-
2		1173660	-	-	-	-	-	-	-	-	-	-	1	1	-	-
2		1173665	-	-	-	-	-	-	1	1	-	-	-	-	1	1
3	Fan Blade	1173721	1	1	-	-	-	-	-	-	-	-	-	-	-	-
3		1173874	-	-	1	1	1	1	-	-	-	-	-	-	-	-
3		1173720	-	-	-	-	-	-	-	-	1	1	-	-	-	-
3		1173661	-	-	-	-	-	-	-	-	-	-	1	1	-	-
3		1172716	-	-	-	-	-	-	1	1	-	-	-	-	1	1
4	Contactora, 30 Amp	1172472	1	1	1	1	1	1	-	-	1	1	1	1	1	1
4	40 Amp	1172786	-	-	-	-	-	-	1	1	-	-	-	-	-	-
5	Capacitor, 370V 30+5 Mfd	1172109	1	1	-	-	-	-	-	-	-	-	-	-	-	-
5	370V 35+5 Mfd	1172110	-	-	1	1	-	-	-	-	-	-	-	-	-	-
5	370V 45+5 Mfd	1172124	-	-	-	-	1	1	-	-	-	-	-	-	-	-
5	370V 50+5 Mfd	1172111	-	-	-	-	-	-	-	-	1	1	-	-	-	-
5	370V 55+5 Mfd	1172123	-	-	-	-	-	-	-	-	-	-	1	1	-	-
5	370V 60+7.5 Mfd	1172299	-	-	-	-	-	-	-	-	-	-	-	-	1	1
5	370V 80+7.5 Mfd	1172296	-	-	-	-	-	-	1	1	-	-	-	-	-	-
6	Condenser Coil	1173648	1	1	-	-	-	-	-	-	-	-	-	-	-	-
6		1174089	-	-	1	1	-	-	-	-	-	-	-	-	-	-
6		1175918	-	-	-	-	1	1	-	-	-	-	-	-	-	-
6		1175016	-	-	-	-	-	-	1	1	-	-	-	-	-	-
6		1175511	-	-	-	-	-	-	-	-	1	1	-	-	-	-
6		1175510	-	-	-	-	-	-	-	-	-	-	1	1	-	-
6		1175512	-	-	-	-	-	-	-	-	-	-	-	-	1	1
7	Service Valve, Suction	1172725	1	1	1	1	-	-	-	-	-	-	-	-	-	-
7		1172726	-	-	-	-	1	1	-	-	1	1	-	-	-	-
7		1172727	-	-	-	-	-	-	1	1	-	-	1	1	1	1
8	Service Valve, Liquid	1173681	1	1	1	1	1	1	1	1	1	1	1	1	1	1
9	Plug, Compressor Harness	1172729	1	1	1	1	-	-	-	-	-	-	-	-	-	-
9		1172793	-	-	-	-	1	1	1	1	-	-	-	-	-	-
9		1172731	-	-	-	-	-	-	-	-	-	-	1	1	-	-
9		1172730	-	-	-	-	-	-	-	-	1	1	-	-	1	1
9		1172732	-	-	-	-	-	-	-	-	-	-	-	-	-	-
10	Grommet, Compressor	1171270	4	4	4	4	4	4	4	4	4	4	4	4	4	4
11	Bolt, Compressor Mounting	1173630	4	4	4	4	4	4	4	4	4	4	4	4	4	4
12	Valve, Reversing	1173649	1	1	1	1	-	-	-	-	-	-	-	-	-	-

- continued on next page -

N2H3 PARTS LIST (continued)																
KEY NO.	DESCRIPTION	PART NO.	N2H318AKA100	N2H318GKA100	N2H324AKA100	N2H324GKA100	N2H330AKB100	N2H330GKB100	N2H336AKB100	N2H336GKB100	N2H342AKB100	N2H342GKB100	N2H348AKB100	N2H348GKB100	N2H360AKB100	N2H360GKB100
12		1172617	-	-	-	-	1	1	-	-	1	1	-	-	-	-
12		1172618	-	-	-	-	-	-	1	1	-	-	1	1	1	1
13	Coil, Rev. Valve 24V	1172619	1	1	1	1	1	1	1	1	1	1	1	1	1	1
14	Harness Assy Rev. Valve Coil	1173988	1	1	1	1	1	1	1	1	1	1	1	1	1	1
15	Accumulator	1173718	1	1	1	1	-	-	-	-	-	-	-	-	-	-
15		1172018	-	-	-	-	1	1	-	-	-	-	-	-	-	-
15		1174939	-	-	-	-	-	-	1	1	-	-	-	-	-	-
15		1173713	-	-	-	-	-	-	-	-	1	1	-	-	-	-
15		1173714	-	-	-	-	-	-	-	-	-	-	1	1	-	-
15		1173719	-	-	-	-	-	-	-	-	-	-	-	-	1	1
16	Capillary Assy	1173632	1	1	1	1	-	-	-	-	-	-	-	-	-	-
16		1174096	-	-	-	-	1	1	1	1	1	1	1	1	1	1
17	Switch, Low Pressure	1173677	1	1	1	1	-	-	-	-	-	-	-	-	-	-
17		1174859	-	-	-	-	1	1	1	1	1	1	1	1	1	1
18	Piston .040	1173990	1	1	-	-	-	-	-	-	-	-	-	-	-	-
18	.049	1173868	-	-	1	1	-	-	-	-	-	-	-	-	-	-
18	.057	1173658	-	-	-	-	1	1	-	-	1	1	-	-	-	-
18	.061	1173663	-	-	-	-	-	-	-	-	-	-	-	-	-	-
18	.065	1173873	-	-	-	-	-	-	-	-	-	-	1	1	-	-
18	.070	1173869	-	-	-	-	-	-	-	-	-	-	-	-	1	1
18	.073	1174017	-	-	-	-	-	-	-	-	-	-	-	-	-	-
18	.078	1174094	-	-	-	-	-	-	1	1	-	-	-	-	-	-
20	Distributor	1172021	1	1	-	-	-	-	-	-	-	-	-	-	-	-
20		1172022	-	-	1	1	1	1	-	-	1	1	-	-	-	-
20		1173998	-	-	-	-	-	-	-	-	-	-	1	1	-	-
20		1173667	-	-	-	-	-	-	-	-	-	-	-	-	1	1
20		1174018	-	-	-	-	-	-	1	1	-	-	-	-	-	-
22	Defrost Sensor	1173637	1	1	1	1	1	1	1	1	1	1	1	1	1	1
23	Muffler	1173638	1	1	1	1	1	1	1	1	1	1	1	1	-	-
23		1173668	-	-	-	-	-	-	-	-	-	-	-	-	1	1
24	Drier	1173639	1	1	1	1	1	1	1	1	1	1	1	1	1	1
26	Board, Defrost Control	1173636	1	1	1	1	1	1	1	1	1	1	1	1	1	1
28	Cap Flare	1172410	1	1	1	1	1	1	1	1	1	1	1	1	1	1
29	Cushion, Accumulator	1172806	1	1	1	1	1	1	1	1	1	1	1	1	1	1
30	Clip, Accumulator	1173640	1	1	1	1	1	1	1	1	1	1	1	1	1	1
31	Retainer, Piston	1173993	1	1	1	1	1	1	1	1	1	1	1	1	1	1
32	Raceway	1173651	1	1	1	1	-	-	-	-	-	-	-	-	-	-
32		1173664	-	-	-	-	-	-	-	-	1	1	1	1	1	1
32		1171428	-	-	-	-	1	1	1	1	-	-	-	-	-	-
32		1175919	-	-	-	-	-	-	1	1	-	-	-	-	-	-
33	Lug, Ground	1172300	1	1	1	1	1	1	1	1	1	1	1	1	1	1
35	Heater, Crankcase	1173944	-	-	-	-	1	1	-	-	-	-	1	1	1	1
35		1173670	-	-	-	-	-	-	1	1	-	-	-	-	-	-
36	Switch, Temp. CC Htr	1173669	-	-	-	-	1	1	1	1	-	-	1	1	1	1
)(Adapter Assy	1173994	1	1	1	1	1	1	1	1	1	1	1	1	1	1

- continued on next page -

N2H3 PARTS LIST (continued)																
KEY NO.	DESCRIPTION	PART NO.	N2H318AKA100	N2H318GKA100	N2H324AKA100	N2H324GKA100	N2H330AKB100	N2H330GKB100	N2H336AKB100	N2H336GKB100	N2H342AKB100	N2H342GKB100	N2H348AKB100	N2H348GKB100	N2H360AKB100	N2H360GKB100
)	Harness Assy.	1174744	-	-	-	-	1	1	1	1	1	1	1	1	1	1
)	O'Ring Piston Retainer	1174951	-	-	-	-	1	1	1	1	1	1	1	1	1	1
A	Panel, Top	1174075	1	1	1	1	1	1	1	1	-	-	-	-	-	-
A		1174079	-	-	-	-	-	-	-	-	1	1	1	1	1	1
B	Nut, Hex	1172740	4	4	4	4	4	4	4	4	4	4	4	4	4	4
C	Grille, Inlet	1173652	1	-	1	-	1	-	-	-	-	-	-	-	-	-
C		1173653	-	1	-	1	-	1	-	-	-	-	-	-	-	-
C		1173674	-	-	-	-	-	-	1	-	-	-	-	-	-	-
C		1173675	-	-	-	-	-	-	-	1	-	-	-	-	-	-
C		1174092	-	-	-	-	-	-	-	-	-	-	-	-	1	-
C		1174095	-	-	-	-	-	-	-	-	-	-	-	-	-	1
C		1172798	-	-	-	-	-	-	-	-	1	-	-	-	-	-
C		1172802	-	-	-	-	-	-	-	-	-	1	-	-	-	-
C		1172746	-	-	-	-	-	-	-	-	-	-	1	-	-	-
C		1172752	-	-	-	-	-	-	-	-	-	-	-	1	-	-
D	Box, Control	1173643	1	1	1	1	1	1	1	1	1	1	1	1	1	1
E	Cover, Control Box	1174097	1	1	1	1	1	1	-	-	-	-	-	-	-	-
E		1175502	-	-	-	-	-	-	-	-	1	1	-	-	-	-
E		1175505	-	-	-	-	-	-	-	-	-	-	1	1	-	-
E		1175508	-	-	-	-	-	-	1	1	-	-	-	-	1	1
F	Panel, Service	1174066	1	1	1	1	1	1	-	-	-	-	-	-	1	1
F		1174085	-	-	-	-	-	-	-	-	-	-	-	-	-	-
F		1174080	-	-	-	-	-	-	1	1	-	-	-	-	-	-
F		1174077	-	-	-	-	-	-	-	-	-	-	1	1	-	-
F		1174071	-	-	-	-	-	-	-	-	1	1	-	-	-	-
G	Pan, Base	1174076	1	1	1	1	1	1	1	1	-	-	-	-	-	-
G		1174081	-	-	-	-	-	-	-	-	1	1	1	1	1	1
L	Guard, Fan	1172764	1	1	1	1	1	1	1	1	-	-	-	-	-	-
L		1172765	-	-	-	-	-	-	1	1	1	1	1	1	1	1
N	Support, Coil	1174068	5	5	5	5	5	5	5	5	5	5	5	5	5	5
P	Strap, Capacitor	1172734	1	1	1	1	1	1	-	-	1	1	1	1	1	1
P		1172735	-	-	-	-	-	-	1	1	-	-	-	-	-	-
)	Screw, Gray Hex 10AB 3/8	1174676	-	-	-	-	14	14	14	14	14	14	14	14	14	14
)	Screw, Gray Hex 10AB 3/8	1174677	-	-	-	-	13	13	13	13	11	11	11	11	11	11
)	Screw, Gray Hex 10AB 3/8	1174678	-	-	-	-	4	4	4	4	4	4	4	4	4	4
)	Manual, Installation	42801500001	1	1	1	1	1	1	1	1	1	1	1	1	1	1
)	Manual, Owners	42802500000	1	1	1	1	1	1	1	1	1	1	1	1	1	1
)	Warranty	40106401002	1	1	1	1	1	1	1	1	1	1	1	1	1	1

