

INSTALLATION INSTRUCTIONS

R-22 Split System Heat Pump

Model Series: N2H3, H2H3, C2H3, T2H3, N2H4

These instructions must be read and understood completely before attempting installation.

Safety Labeling and Signal Words

DANGER, WARNING, CAUTION, and NOTE

The signal words **DANGER**, **WARNING**, **CAUTION**, and **NOTE** are used to identify levels of hazard seriousness. The signal word **DANGER** is only used on product labels to signify an immediate hazard. The signal words **WARNING**, **CAUTION**, and **NOTE** will be used on product labels and throughout this manual and other manuals that may apply to the product.

DANGER – Immediate hazards which **will** result in severe personal injury or death.

WARNING – Hazards or unsafe practices which **could** result in severe personal injury or death.

CAUTION – Hazards or unsafe practices which **may** result in minor personal injury or product or property damage.

NOTE – Used to highlight suggestions which **will** result in enhanced installation, reliability, or operation.

Signal Words in Manuals

The signal word **WARNING** is used throughout this manual in the following manner:



The signal word **CAUTION** is used throughout this manual in the following manner:



Signal Words on Product Labeling

Signal words are used in combination with colors and/or pictures on product labels.

TABLE OF CONTENTS

Inspect New Unit	2
Safety Considerations	2
Location	2
Clearances	2 – 3
Unit Support	4
Refrigeration System	4 – 9
Electrical Wiring	9 – 10
Defrost System	11
Start-up Procedure	12
Refrigerant Charge	12
Sequence of Operation	13
Troubleshooting	13
Maintenance	13



DEATH, PERSONAL INJURY, AND/OR PROPERTY DAMAGE HAZARD

Failure to carefully read and follow this warning could result in equipment malfunction, property damage, personal injury and/or death.

Installation or repairs made by unqualified persons could result in equipment malfunction, property damage, personal injury and/or death.

The information contained in this manual is intended for use by a qualified service technician familiar with safety procedures and equipped with the proper tools and test instruments.

Installation must conform with local building codes and with the National Electrical Code NFPA70 current edition or Canadian Electrical Code Part 1 CSA C.22.1.

INSPECT NEW UNIT

After uncrating unit, inspect thoroughly for hidden damage. If damage is found, notify the transportation company immediately and file a concealed damage claim.

SAFETY CONSIDERATIONS

Consult a qualified installer, service agency, or the dealer/distributor for information and assistance. The qualified installer must use factory authorized kits and accessories when modifying this product. Refer to the individual instructions packaged with the kit or accessory when installing.

The weight of the product requires careful and proper handling procedures when lifting or moving to avoid personal injury. Use care to avoid contact with sharp or pointed edges.

Follow all safety codes. Wear safety glasses, protective clothing, and work gloves. Use a heat sinking material – such as a wet rag – during brazing operations. Keep a fire extinguisher available. Consult local codes and the National Electric Code (NEC) for special requirements.

LOCATION

Check local codes for regulations concerning zoning, noise, platforms, and other issues.

Locate unit away from fresh air intakes, vents, or bedroom windows. Noise may carry into the openings and disturb people inside.

Locate unit in a well drained area, or support unit high enough so that water runoff will not enter the unit.

Locate unit away from areas where heat, lint, or exhaust fumes will be discharged onto unit (as from dryer vents).

CLEARANCES

Nominal minimum clearances are 48 inches above unit for discharge air and 18 inches on each side of the coil for intake air. Clearance on any **one** side of the coil (normally between unit and structure) may be reduced to 6 inches. Nominal minimum clearances are based on a solid parallel object such as a wall or roof overhang.

The clearance may be reduced for a single object with small surface area, such as the end of a wall, outside corner of a wall, fence section, post, etc. As a general rule, the minimum clearance from the unit should equal the width of the object. For example, a 6 inch fence post should be a minimum of 6 inches from the unit.

Do not install unit under roof overhangs unless gutters are present. A minimum vertical clearance of 48 inches is required to the overhang.

Improper installation, adjustment, alteration, service or maintenance can void the warranty.



WARNING

ELECTRICAL SHOCK HAZARD

Failure to turn off the main (remote) electrical disconnect device could result in personal injury or death.

Before installing, modifying or servicing system, turn OFF the main (remote) electrical disconnect device. There may be more than one disconnect device.

Locate unit away from recessed or confined areas where recirculation of discharge air may occur (refer to CLEARANCES section of this document).

Roof-top installation is acceptable providing the roof will support the unit and provisions are made for water drainage and noise/vibration dampening.

NOTE: Roof mounted units exposed to wind may require wind baffles. Consult the manufacturer for additional information.

Inside corner locations on single story structures require evaluation. Large overhanging soffits may cause air recirculation in a corner area even though recommended minimum clearances are maintained. As a guide, locate the unit far enough out so that half of the discharge grille is out from under the soffit.

When placing two or more units side-by-side, provide a minimum of 18 inches between units.

Provide minimum service clearance of 24 inches from control box corner and side service panel.

Refer to Figure 1.

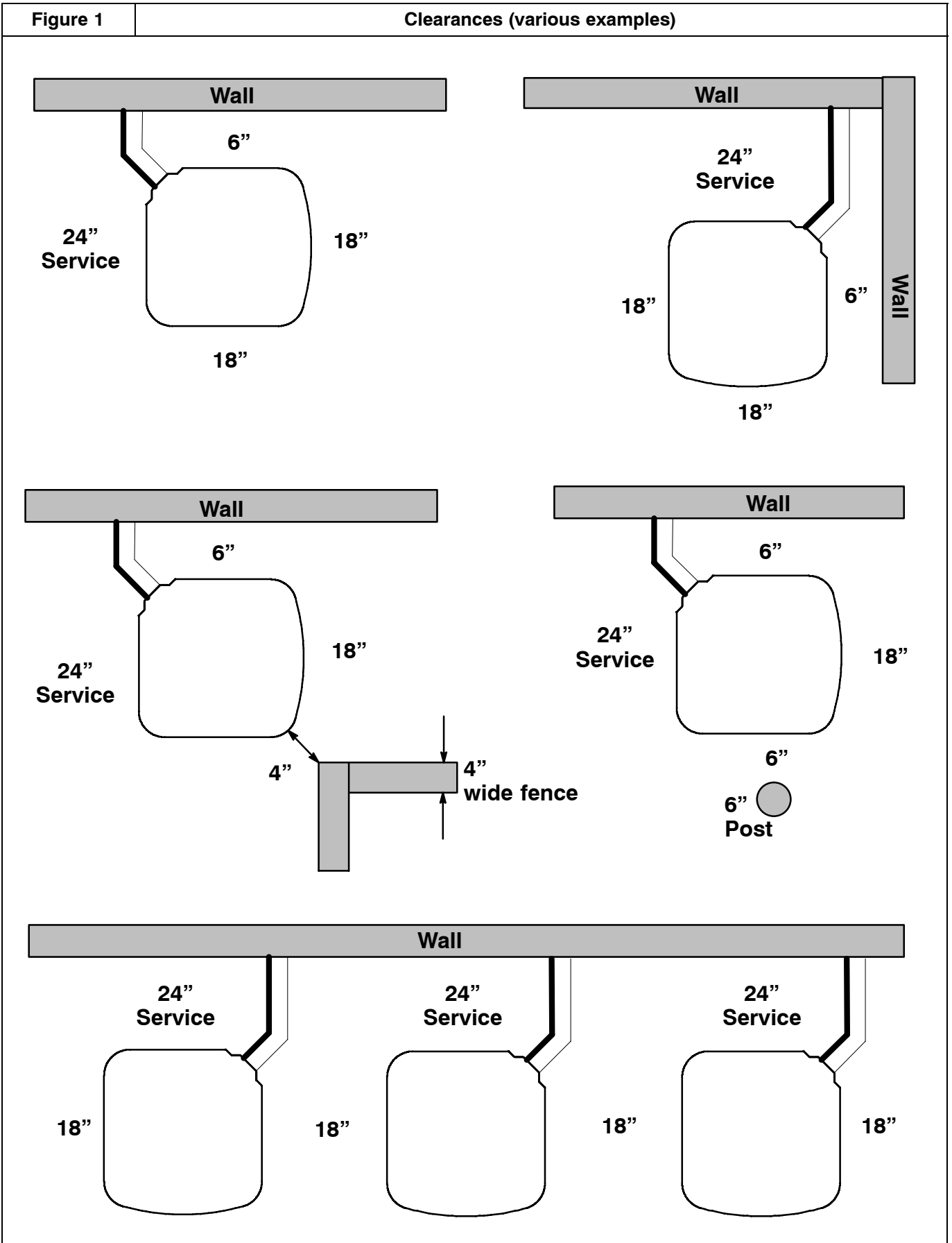

UNIT SUPPORT

NOTE: Unit must be level ± 2 degrees ($\frac{3}{8}$ inch rise or fall per foot of run) or compressor may not function properly.

A. GROUND LEVEL INSTALLATION

The unit must be level and supported above grade by beams, platform, or a pad. Platform or pad can be of open or solid construction but should be of permanent materials such as concrete, bricks, blocks, steel, or pressure-treated timbers approved for ground contact. Soil conditions must be considered so that the platform or pad does not shift or settle and leave the unit partially supported. Minimum pad dimensions are shown in Figure 2.

If beams or an open platform are used for support, it is recommended that the soil be treated or area be graveled to reduce the growth of grasses and weeds.

To minimize vibration or noise transmission, it is recommended that supports not be in contact with the building structure. However, slabs on grade constructions with an extended pad are normally acceptable.

⚠ CAUTION

PROPERTY DAMAGE HAZARD

Failure to follow this caution may result in property damage.

Top surface of platform must be above estimated snowfall level to prevent snow blocking coil and to allow water melt to drain from unit.

B. ROOF TOP INSTALLATION

This type of installation is not recommended on wood frame structures where low noise levels are required.

Supporting structure or platform for the unit must be level. If installation is on a flat roof, locate unit minimum 6 inches above roof level.

Place the unit over one or more load bearing walls. If there are several units, mount them on platforms that are self-supporting and span several load bearing walls. These suggestions are to minimize noise and vibration transmission through the structure. If the structure is a home or apartment, avoid locating the unit over bedrooms or study.

NOTE: When unit is to be installed on a bonded guaranteed roof, a release must be obtained from the building owner to free the installer from all liabilities.

C. FASTENING UNIT DOWN

If conditions or local codes require the unit be attached in place, remove the knockouts in the base pan and install tie down bolts through the holes (refer to Figure 2).

Contact local distributor for hurricane hold-down details and the P.E. (Professional Engineer) certification, when required.

⚠ CAUTION

PROPERTY DAMAGE HAZARD

Failure to follow this caution may result in property damage.

Inadequate unit support may cause excessive vibration, noise, and/or stress on the refrigerant lines, leading to refrigerant line failure.

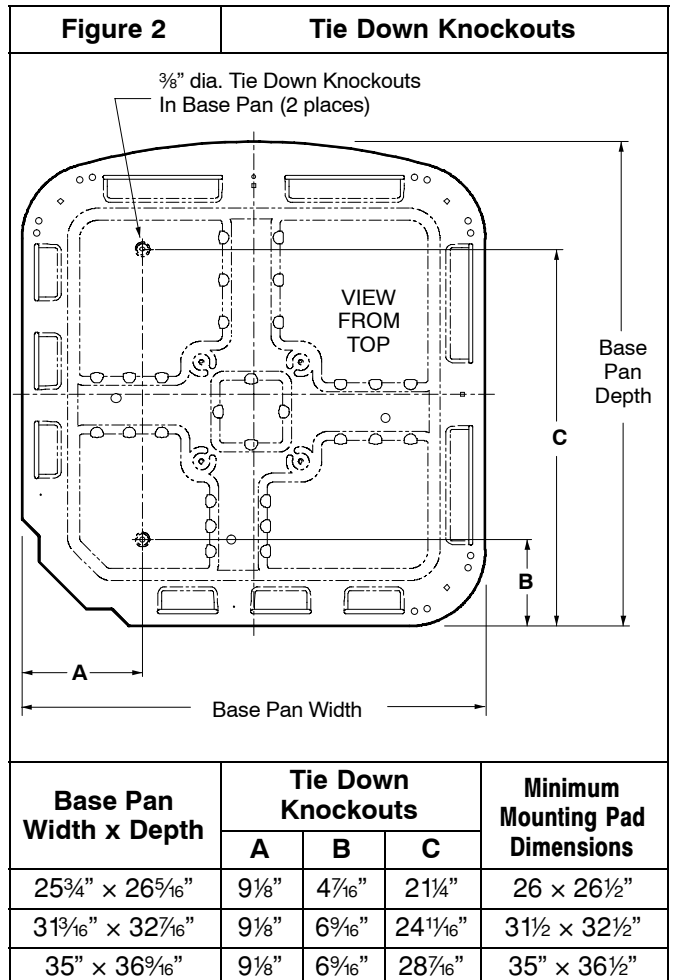

REFRIGERATION SYSTEM

A. COMPONENT MATCHES

Check to see that the proper system components are in place, especially the indoor coil.

R-22 outdoor units can only be used with R-22 specific indoor coils. If there is a refrigerant mis-match, consult the indoor coil manufacturer to determine if a refrigerant conversion kit is available for the indoor coil.

This outdoor unit is designed for use only with indoor coils that utilize a hard shut-off TXV refrigerant metering device. If any other type of metering device is installed on the indoor coil, consult the indoor coil manufacturer to determine if a hard shut-off TXV conversion kit is available.

⚠ CAUTION

PRODUCT DAMAGE HAZARD
 Failure to follow this caution may result in product damage.

Indoor coil and outdoor unit must be listed as a certified combination (match) in the ARI Unitary Directory of Certified Products.
 Indoor coil must have R-22 specific, hard shut-off TXV refrigerant metering device.

When installing a hard shut-off TXV on an indoor coil, follow the instructions provided with the new TXV.

A typical hard shut-off TXV installation is shown in Figure 3.

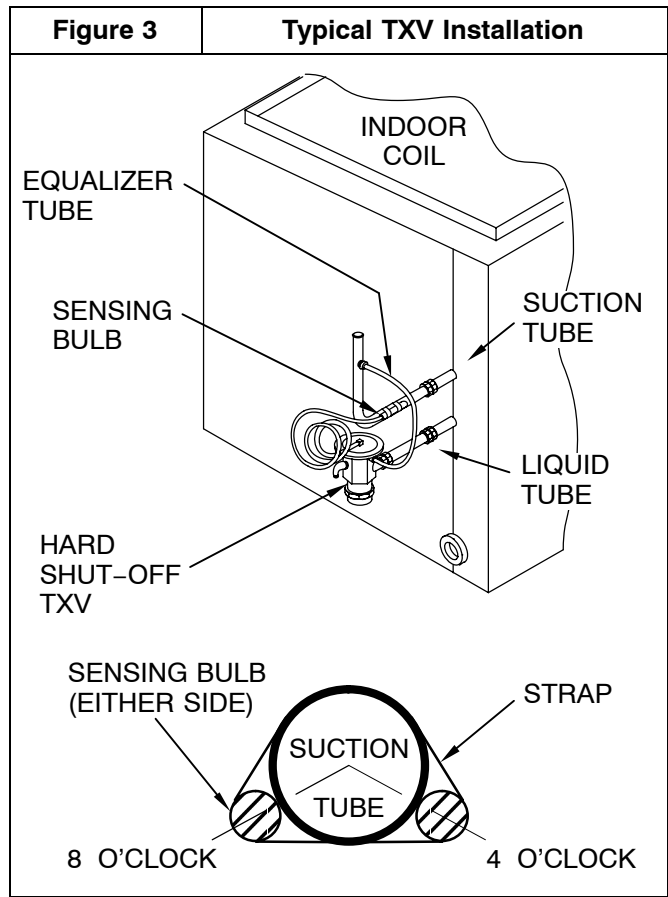

B. REFRIGERANT LINE SETS

The refrigerant line set must be properly sized to assure maximum efficiency and proper oil circulation. Select line set tube diameters as specified in Figure 4.

NOTE: Total line set length must not exceed 200 feet.

NOTE: A crankcase heater must be used when the refrigerant line length exceeds 80 feet.

If outdoor unit is more than 10 feet higher than the indoor coil, refer to the Extended Length Refrigeration Piping Manual for instructions.

NOTE: When the outdoor unit is higher than the indoor coil, the vertical separation must not exceed 100 feet.

NOTE: When the outdoor unit is lower than the indoor coil, the vertical separation must not exceed 50 feet.

If it is necessary to add refrigerant line in the field, use dehydrated or dry, sealed, deoxidized, copper refrigeration tubing. Do not use copper water pipe.

Do not remove rubber plugs or caps from copper tubing until connections are ready to be made.

Be extra careful when bending refrigeration tubing. Tubing can “kink” easily, and if this occurs, the entire length of tubing must be replaced.

⚠ WARNING

PERSONAL INJURY HAZARD
 Failure to relieve system pressure could result in personal injury and/or death.

Relieve pressure and recover all refrigerant before servicing existing equipment, and before final unit disposal. Use all service ports and open all flow-control devices, including solenoid valves.

⚠ CAUTION

UNIT OPERATION HAZARD
 Failure to follow this caution may result in improper product operation.

Do not leave system open to atmosphere any longer than absolutely required for installation. Internal system components – especially refrigerant oils – are extremely susceptible to moisture contamination. Keep ends of tubing sealed during installation until the last possible moment.

Figure 4 Model Size	R-22 Line Set Tube Diameter (Liquid Tube Always 3/8" dia.)			
	Service Valve Fittings		Line Set < 80 feet long	Line Set 80 – 200 feet long
	Liquid	Suction	Suction Line Diameter	Suction Line Diameter
18 (1½ ton), 24 (2 ton)	3/8"	5/8"	5/8"	3/4"
30 (2½ ton)	3/8"	3/4"	3/4"	3/4"
36 (3 ton)	3/8"	3/4"	3/4"	7/8"
42 (3½ ton), 48 (4 ton)	3/8"	7/8"	7/8"	1 1/8"
60 (5 ton)	3/8"	7/8"	1 1/8"	1 1/8"

NOTE: If the line set length exceeds 80 feet, also refer to Extended Length Refrigeration Piping Manual for additional information.

C. ROUTING AND SUSPENDING REFRIGERANT LINES

Run refrigerant lines as straight and direct as possible, avoiding unnecessary bends and turns. Always insulate the entire suction line. Both lines should be insulated when routed through an attic or when routed through an underground raceway.

When routing refrigerant lines through a foundation or wall, do not allow refrigerant lines to come in direct contact with the building structure. Make openings large

enough so that lines can be wrapped with extra insulation. Fill all gaps with RTV caulk. This will prevent noise transmission between the tubing and the foundation or wall.

Along floor or ceiling joists, suspend refrigerant lines so that they do not contact the building structure, water pipes, or ductwork. Use insulated or suspension type hangers. Metal straps must be at least 1" wide to avoid cutting into the tube insulation. Keep the liquid and suction lines separate. Refer to Figure 5.

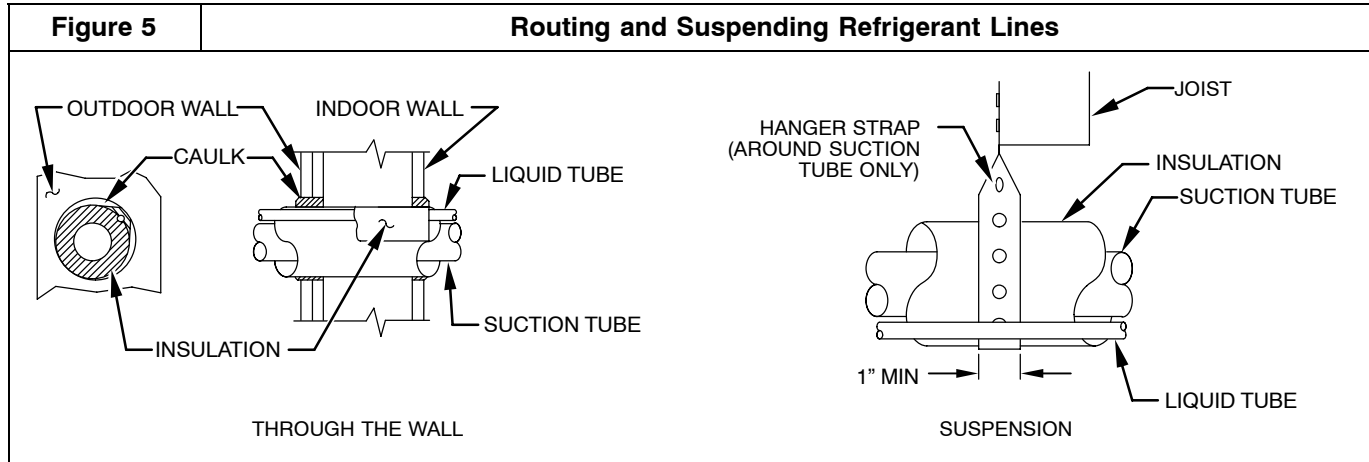

⚠ CAUTION

UNIT OPERATION HAZARD
 Failure to follow this caution may result in improper product operation.
 Do not bury more than 36" of line set underground. Refrigerant may migrate to cooler buried section during extended periods of unit shut-down, causing refrigerant slugging and possible compressor damage at start-up.
 If ANY section of the line set is buried underground, provide a minimum 6" vertical rise at the service valve.

D. OUTDOOR UNIT HIGHER THAN INDOOR UNIT

Proper oil return to the compressor should be maintained with suction gas velocity. If velocities drop below 1500 fpm (feet per minute), oil return will be decreased. To maintain suction gas velocity, do not upsize vertical suction risers. Use the "<80 feet" suction line sizes shown Figure 4.

Install oil traps every 20 feet of vertical suction line riser (refer to Figure 6).

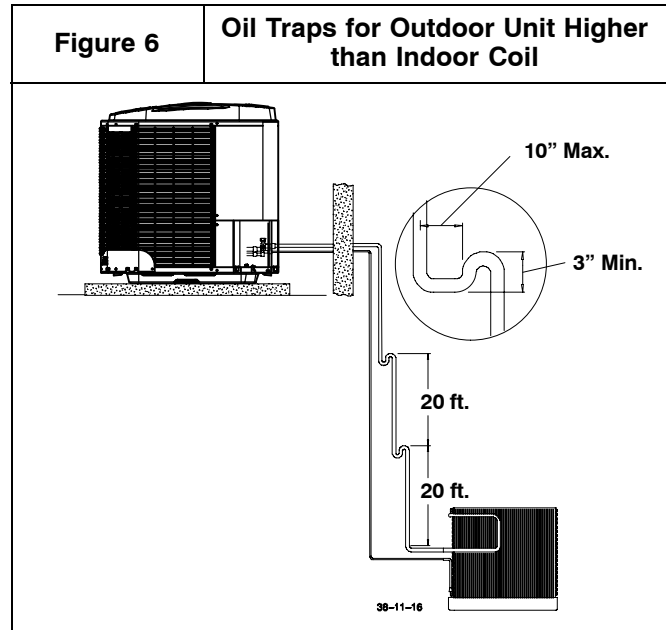

E. LIQUID LINE FILTER-DRIER

Outdoor units are shipped with an appropriate filter-drier for installation in the liquid line. Leave the plugs in the tube ends until the filter-drier is installed. The optimal location for the filter-drier is close to the indoor coil. Heat pump filter-driers are "bi-flow" type. Either end can be pointed towards indoor coil. Refer to Figure 7.

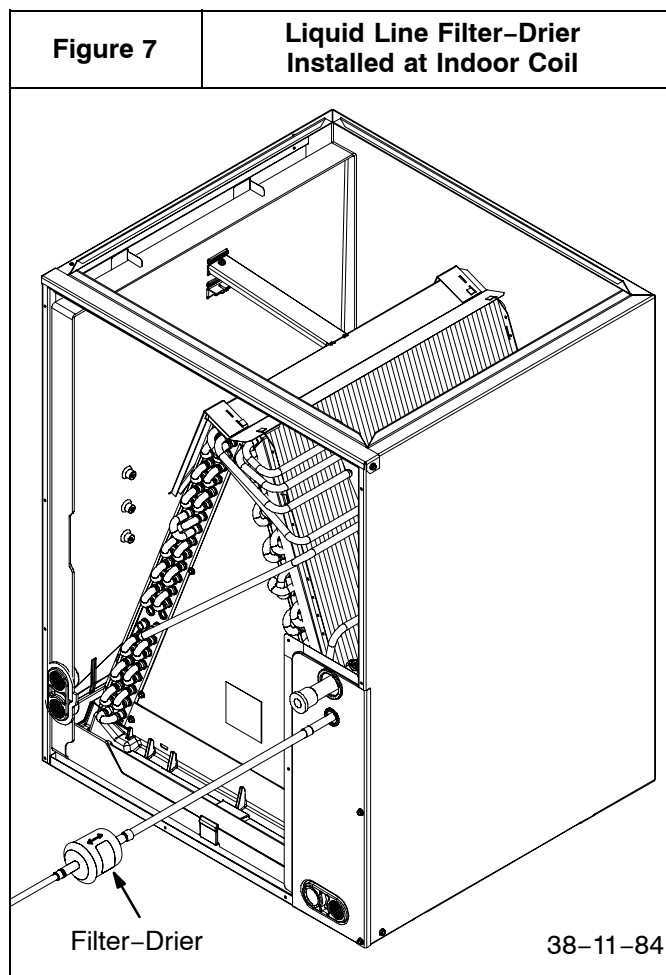

F. SERVICE VALVES

Service valves are closed and plugged from the factory. Outdoor units are shipped with a refrigerant charge sealed in the unit. Leave the service valves closed until all other refrigeration system work is complete or the charge will be lost. Leave the plugs in place until line set tubing is ready to be inserted.

Heat pumps require a piston metering device in the liquid service valve for proper heating operation. Piston and retainer are shipped in the piston body of the liquid service valve, temporarily held in place with a plastic cap. Do not remove the plastic cap until line set tubing is ready to be installed.

Refer to Figure 8 and follow these steps for piston installation:

1. Remove plastic cap holding piston and retainer in piston body of liquid service valve.

2. Check that piston size (stamped on side of piston) matches with number listed on unit rating plate. Return piston to piston body of liquid service valve (either direction). Return retainer to piston body. **NOTE:** Small end of retainer fits inside piston body, with O-ring sealing against inside of piston body
3. Find plastic bag taped to unit containing copper adapter tube with brass nut.
4. Install adapter tube against retainer and thread brass nut onto liquid service valve. Tighten nut finger tight, then wrench additional 1/2 turn only.

Service valve bodies are brass and suction tube stub is copper.

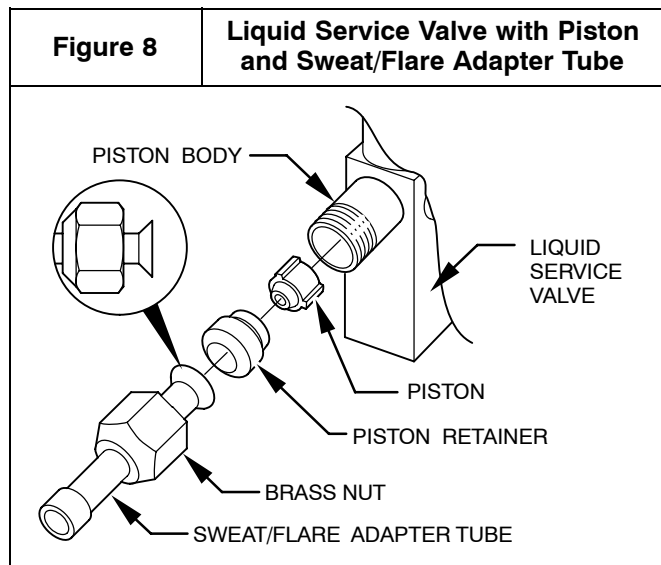

G. BRAZING CONNECTIONS

	WARNING
FIRE HAZARD	
Failure to remove refrigerant and oil charge before brazing could result in personal injury, death, and/or property damage.	
Refrigerant and oil mixture could ignite and burn as it escapes and contacts brazing torch. Make sure the refrigerant charge is properly removed from both the high and low sides of the system before brazing any component or lines.	

Clean line set tube ends with emery cloth or steel brush. Remove any grit or debris.

Insert line set tube ends into service valve tube stubs.

Apply heat absorbing paste or heat sink product between service valve and joint. Wrap service valves with a heat sinking material such as a wet cloth.

Braze joints using a Sil-Fos or Phos-copper alloy.

⚠ CAUTION

PRODUCT DAMAGE HAZARD

Failure to follow this caution may result in product damage.

Braze with Sil-Fos or Phos-copper alloy on copper-to-copper joints and wrap a wet cloth around rear of fitting to prevent damage to TXV.

H. EVACUATING LINE SET AND INDOOR COIL

The unit is shipped with a factory refrigerant charge. The liquid line and suction line service valves have been closed after final testing at the factory. Do not disturb these valves until the line set and indoor coil have been evacuated and leak checked, or the charge in the unit may be lost.

NOTE: Do not use any portion of the factory charge for purging or leak testing. The factory charge is for filling the system only after a complete evacuation and leak check has been performed.

⚠ CAUTION

PRODUCT DAMAGE HAZARD

Failure to follow this caution may result in product damage.

Never use the outdoor unit compressor as a vacuum pump. Doing so may damage the compressor.

Line set and indoor coil should be evacuated using the recommended deep vacuum method of 500 microns. If deep vacuum equipment is not available, the alternate triple evacuation method may be used by following the specified procedure.

If vacuum must be interrupted during the evacuation procedure, always break vacuum with dry nitrogen.

Deep Vacuum Method

The deep vacuum method requires a vacuum pump capable of pulling a vacuum to 500 microns and a vacuum gauge capable of accurately measuring this vacuum level. The deep vacuum method is the most positive way of assuring a system is free of air and water.

Watch the vacuum gauge as the system is pulling down. The response of the gauge is an indicator of the condition of the system (refer to Figure 9).

With no leaks in the system, allow the vacuum pump to run for 30 minutes minimum at the deep vacuum level.

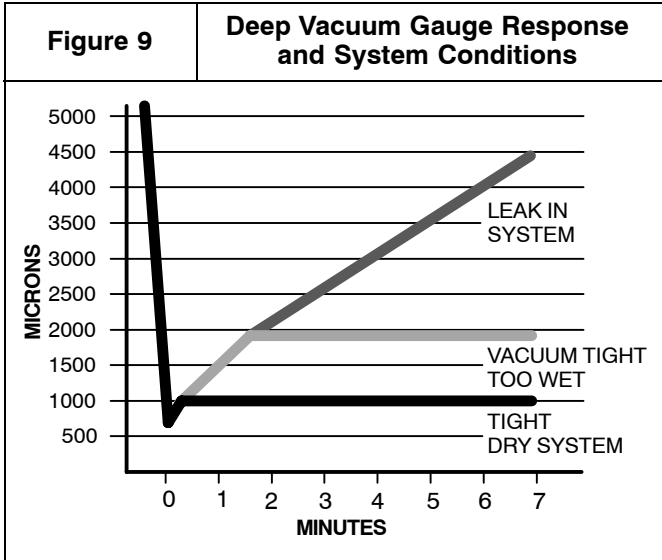

Triple Evacuation Method

The triple evacuation method should only be used when system does not contain any water in liquid form and vacuum pump is only capable of pulling down to 28 inches of mercury. Refer to Fig. 10 and proceed as follows:

1. Pull system down to 28 inches of mercury and allow pump to continue operating for an additional 15 minutes.
2. Close manifold valves or valve at vacuum pump and shut off vacuum pump.
3. Connect a nitrogen cylinder and regulator to system and fill with nitrogen until system pressure is 2 psig.
4. Close nitrogen valve and allow system to stand for 1 hour. During this time, dry nitrogen will diffuse throughout the system absorbing moisture.
5. Repeat this procedure as indicated in Figure 10.
6. After the final evacuate sequence, confirm there are no leaks in the system. If a leak is found, repeat the entire process after repair is made.

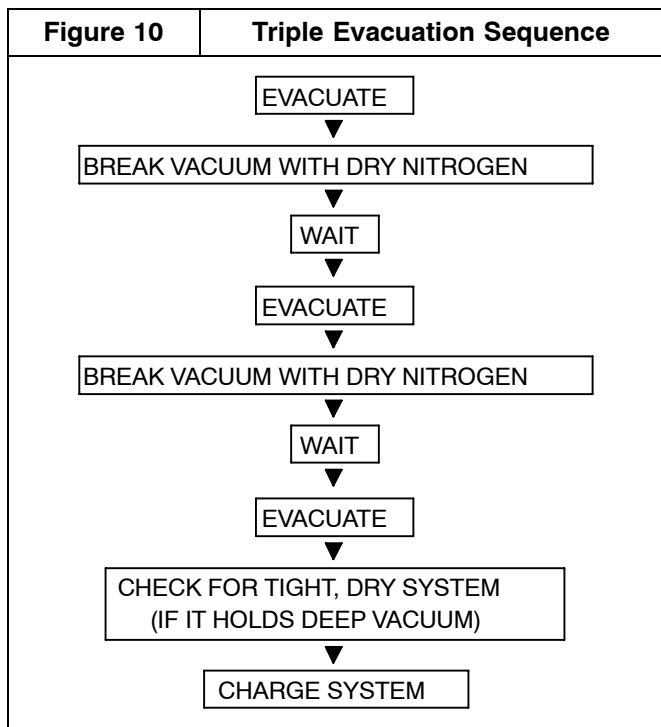

I. OPENING SERVICE VALVES

Outdoor units are shipped with a refrigerant charge sealed in the unit. Opening the service valves releases this charge into the system.

NOTE: Open the Suction service valve first. If the Liquid service valve is opened first, oil from the compressor may be drawn into the indoor coil TXV, restricting refrigerant flow and affecting operation of the system.

Remove Suction service valve cap and insert a hex wrench into the valve stem. Hold the valve body steady with an end-wrench and back out the stem by turning the hex wrench counterclockwise. Turn the stem until it just contacts the rolled lip of the valve body.

After the refrigerant charge has bled into the system, open the Liquid service valve.

NOTE: These are not back-seating valves. It is not necessary to force the stem tightly against the rolled lip.

The service valve cap is a primary seal for the valve and must be properly tightened to prevent leaks. Make sure cap is clean and apply refrigerant oil to threads and sealing surface on inside of cap.

Tighten cap finger tight and then tighten additional 1/8 of a turn (1 wrench flat) to properly seat the sealing surfaces.

J. GAUGE PORTS

Check for leaks at the schrader ports and tighten valve cores if necessary. Install plastic caps finger tight.

ELECTRICAL WIRING

⚠ WARNING

ELECTRICAL SHOCK HAZARD

Failure to turn off the main (remote) electrical disconnect device could result in personal injury or death.

Before installing, modifying or servicing system, turn OFF the main (remote) electrical disconnect device. There may be more than one disconnect device.

Supply voltage must be 208/230 volts (197 volt minimum to 253 volts maximum) 60 Hz single phase.

Outdoor units are approved for use with copper conductors only. Do not use aluminum wire.

Refer to unit rating plate for minimum circuit ampacity and circuit protection requirements.

Grounding

Permanently ground unit in accordance with the National Electrical Code and local codes or ordinances. Use a copper conductor of the correct size from the grounding lug in control box to a grounded connection in the service panel or a properly driven and electrically grounded ground rod.

Wiring Connections

Make all outdoor electrical supply (Line Voltage) connections with raintight conduit and fittings. Most codes require a disconnect switch outdoors within sight of the unit. Consult local codes for special requirements.

Route electrical supply (Line Voltage) wiring through knockout hole in bottom of Control Box. Connect wires to Contactor and Ground Lug according to Wiring Diagram on unit. Also refer to Figure 11.

Route thermostat wiring through rubber grommet in bottom of Control Box. Low voltage lead wires are provided in the control box for connection to thermostat wires (use wire nuts). Refer to Wiring Diagram on unit and Figure 12 for low voltage wiring examples.

NOTE: Use No. 18 AWG (American Wire Gage) color-coded, insulated (35 °C minimum) wire. If thermostat is located more than 100 feet (30.5 m) from unit as measured along the control voltage wires, use No. 16 AWG color-coded wires to avoid excessive voltage drop.

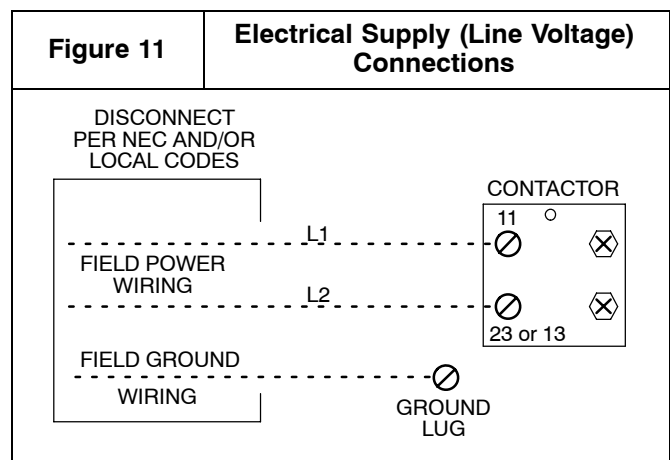

Figure 12

Typical Thermostat (Control Circuit) Connections

NOTE: WHEN USING OUTDOOR THERMOSTATS, W₂ MUST BE ENERGIZED WHEN REQUESTING SUPPLEMENTAL HEAT.

SYSTEMS WITH ONE OUTDOOR THERMOSTAT

SYSTEMS WITH TWO OUTDOOR THERMOSTATS

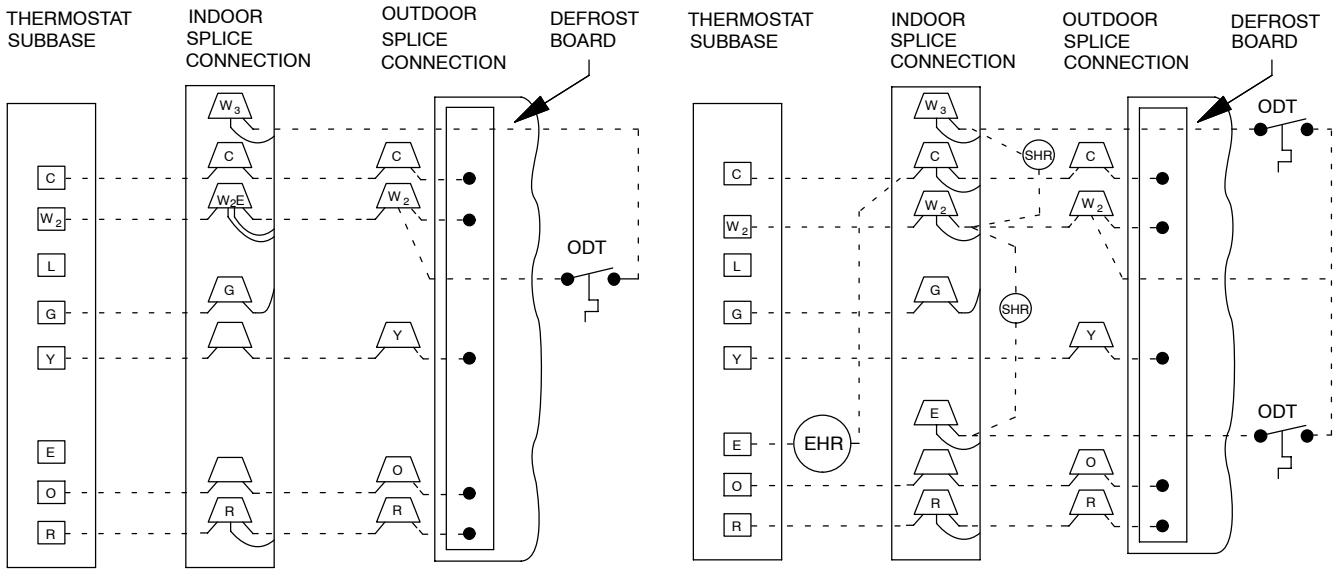

REMOVE WIRES FROM CRIMP NUT IN INDOOR FAN COIL WHEN INSTALLING OUTDOOR THERMOSTATS.

SYSTEMS WITHOUT OUTDOOR THERMOSTATS

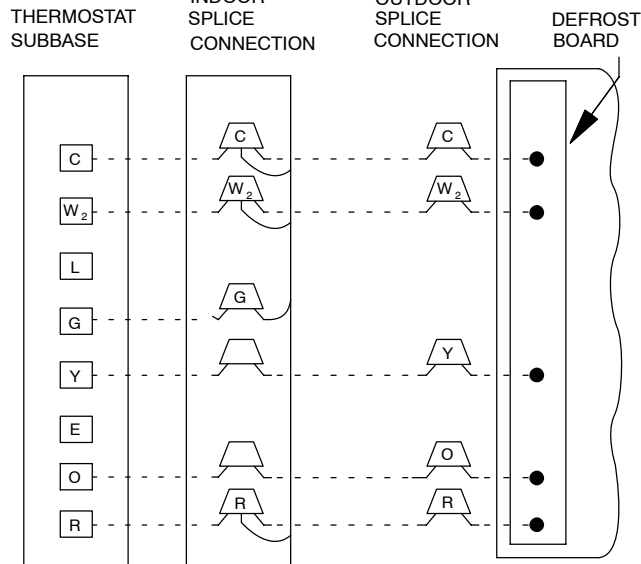

LEGEND

- 24-V FACTORY WIRING
- - - - - 24-V FIELD WIRING
- FIELD SPLICE CONNECTION
- OUTDOOR THERMOSTAT
- EMERGENCY HEAT RELAY
- SUPPLEMENTAL HEAT RELAY

DEFROST SYSTEM

A. DEFROST THERMOSTAT

The defrost thermostat is factory installed on a short tube stub extending from the coil end plate. Refer to Figure 13 and confirm that the thermostat is securely fastened in place on the tube stub.

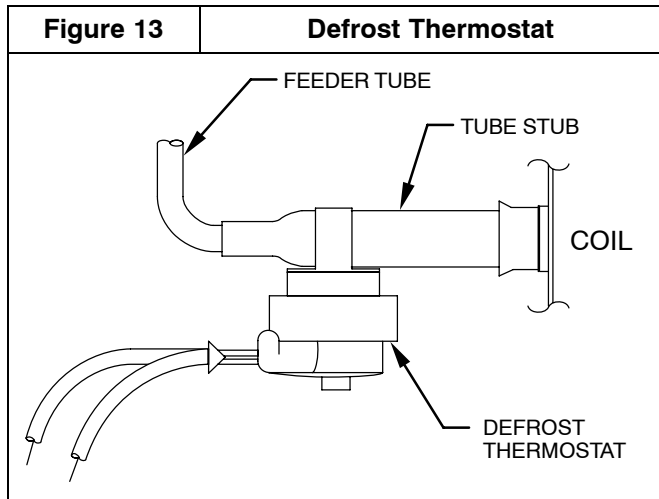

B. DEFROST CONTROL BOARD

The defrost board is a time/temperature control which includes a field-selectable time period between defrost cycles of 30, 60, or 90 minutes (quick-connects located at board edge, factory set at 90 minutes).

Defrost mode is identical to cooling mode except that outdoor-fan motor stops and second-stage heat is turned on to continue warming conditioned space.

Initially, the defrost cycle timer starts when the contactor is energized and a 24 VAC signal is present on the T1 terminal. Then the defrost cycle begins when the defrost thermostat is closed and the cycle timer times out (30, 60, 90 or minutes).

To initiate a forced defrost cycle, the defrost thermostat must be closed. This can be accomplished as follows:

1. Turn off power to outdoor unit.
2. Disconnect outdoor fan-motor lead from OF2 on control board (refer to Figure 14). Tape lead to prevent grounding.
3. Restart unit in heating mode, allowing frost to accumulate on outdoor coil.
4. After a few minutes in heating mode, liquid line temperature should drop below closing point of defrost thermostat (approximately 32 °F).
5. Short between speed-up terminals with a flat-bladed screwdriver (refer to Figure 14). This reduces the timing sequence to 7, 14, or 21 seconds (30, 60, or 90 minute defrost selection, respectively).
6. When you hear reversing valve change position, remove screwdriver immediately; otherwise, control will terminate normal 10-minute defrost cycle in approximately 2 seconds.

NOTE: Length of defrost cycle is dependent upon length of time it takes to remove screwdriver from test pins after reversing valve has shifted.

7. Unit will remain in defrost for remainder of defrost-cycle time or until defrost thermostat reopens at approximately 65 °F coil temperature of liquid line.
8. Turn off power to outdoor unit and reconnect fan-motor lead to OF2 on control board (refer to Figure 14).

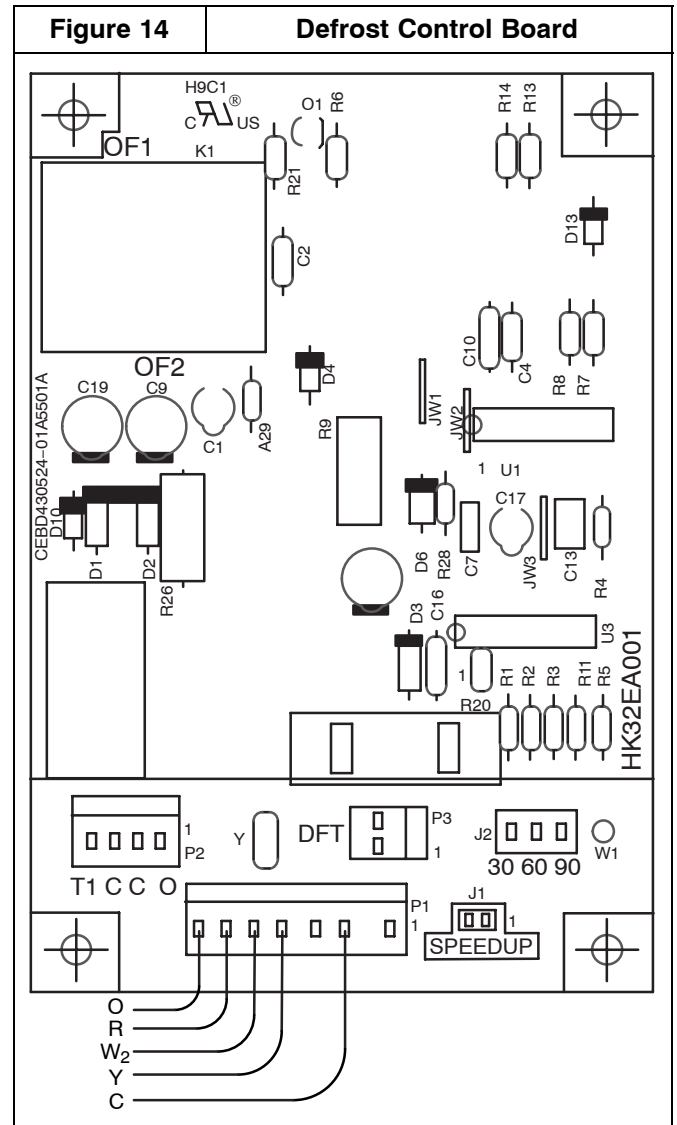

START-UP PROCEDURE

1. Set indoor thermostat selector switch to OFF.
2. Turn ON all electrical disconnect devices.
3. If unit has a crankcase heater, energize the heater and wait 24 hours before proceeding.
4. Set indoor thermostat at desired temperature. Be sure setpoint is below indoor ambient temperature to call for cooling, or above indoor ambient to call for heating.
5. Set indoor thermostat selector switch to COOL or HEAT. Operate unit for minimum 10 minutes, then check the system refrigerant charge.

REFRIGERANT CHARGE

A. COOLING MODE

Outdoor units are shipped with a refrigerant charge to match a specific indoor coil and 15 feet of refrigerant line. If shorter or longer refrigerant lines or a different indoor coil are used, the charge will have to be adjusted.

For different line lengths, add or remove charge based on 0.6 ounces charge per foot of difference. For example, a 25 foot line set is 10 feet longer than the specified 15 feet. Add 0.6 ounces charge for each of the extra 10 feet:

$$10 \times 0.6 = 6.0 \text{ ounces additional charge}$$

This outdoor unit is designed for use only with indoor coils that utilize a hard shut-off TXV refrigerant metering device. With a hard shut-off indoor TXV, use the subcooling method to make final charge adjustments:

1. Operate unit a minimum of 10 minutes before checking charge.
NOTE: If outdoor unit has a 2-speed fan motor, motor will operate in low speed when outdoor ambient temperature is below 82 °F. Pull one of the yellow low voltage wires off the fan control and the unit will default to high speed fan for servicing. Reconnect wire after servicing.
2. Measure liquid service valve pressure by attaching an accurate gauge to service port.
3. Measure liquid line temperature by attaching an accurate thermistor type sensor or electronic thermometer to liquid line near outdoor coil.
4. Refer to unit rating plate for required subcooling temperature.
5. Refer to Figure 15. Find the required liquid line temperature where the rating plate subcooling temperature intersects measured liquid service valve pressure.
6. If the measured liquid line temperature is higher than the chart number, add refrigerant to lower the measured temperature.
NOTE: When adding refrigerant, charge in liquid form, using a flow restricting device, into the suction port.
If the measured liquid line temperature is lower than the chart number, reclaim refrigerant to raise the measured temperature.
Tolerance is ± 3 °F.

on chart, system refrigerant charge may not be correct. Do not use chart to adjust refrigerant charge.

NOTE: When charging is necessary during heating season, charge must be weighed in accordance with unit rating plate ± 0.6 ounces per foot of $\frac{3}{8}$ inch liquid line above or below 15 feet respectively.

Figure 15	R-22 Required Liquid Line Temperature (°F) – Cooling Mode			
	Rating Plate (required) Subcooling Temperature (°F)			
Measured Liquid Pressure (psig)	5	10	15	20
134	71	66	61	56
141	74	69	64	59
148	77	72	67	62
156	80	75	70	65
163	83	78	73	68
171	86	81	76	71
179	89	84	79	74
187	92	87	82	77
196	95	90	85	80
205	98	93	88	83
214	101	96	91	86
223	104	99	94	89
233	107	102	97	92
243	110	105	100	95
253	113	108	103	98
264	116	111	106	101
274	119	114	109	104
285	122	117	112	107
297	125	120	115	110
309	128	123	118	113
321	131	126	121	116
331	134	129	124	119
346	137	132	127	122
359	140	135	130	125

B. HEATING MODE

To check system operation during heating cycle, refer to the Tech Label on outdoor unit. This chart indicates whether a correct relationship exists between system operating pressure and air temperature entering indoor and outdoor units. If pressure and temperature do not match

SEQUENCE OF OPERATION

A. COOLING MODE

On a call for cooling, the thermostat makes circuits R-O, R-Y, and R-G. Circuit R-O energizes reversing valve, switching it to cooling position. Circuit R-Y energizes contactor, starting outdoor fan motor and compressor. Circuit R-G energizes indoor unit blower relay, starting indoor blower motor.

When thermostat is satisfied, its contacts open, de-energizing contactor and blower relay. Compressor and motors stop.

NOTE: If indoor unit is equipped with a time-delay relay circuit, the blower runs an additional length of time to increase system efficiency. (Applies to both cooling and heating modes.)

B. HEATING MODE

On a call for heating, the thermostat makes circuits R-Y and R-G (circuit R-O is NOT made, and the reversing valve stays in the de-energized, heating position). Circuit R-Y energizes contactor, starting outdoor fan motor and compressor. Circuit R-G energizes indoor blower relay, starting blower motor. If the room temperature continues to fall, circuit R-W2 is made through the second-stage room thermostat bulb. Circuit R-W2 energizes a sequencer, bringing on the first bank supplemental electric heat and providing electrical potential to the second heater sequencer (if used). If outdoor temperature falls below the setting of the outdoor thermostat (field-installed option), contacts close to complete the circuit and bring on the second bank of supplemental electric heat.

When the thermostat is satisfied, its contacts open, de-energizing contactor, blower relay, and sequencer. Compressor, motors, and heaters stop.

TROUBLESHOOTING

Some models are factory equipped with the Comfort Alert™ Diagnostics device in the control box (refer to Figure 16). Comfort Alert provides around-the-clock monitoring for common electrical problems, compressor defects, and broad system faults. If trouble is detected, an alert code is displayed with a flashing LED indicator. Alert codes are listed in Figure 17.

The device is factory wired and requires no modification. Low voltage lead wires are provided in the control box for connection to thermostat wires (use wire nuts).

The Comfort Alert device operates by monitoring the compressor power leads and the thermostat demand signal (Y terminal). It draws constant 24 VAC power at the R and C terminals.

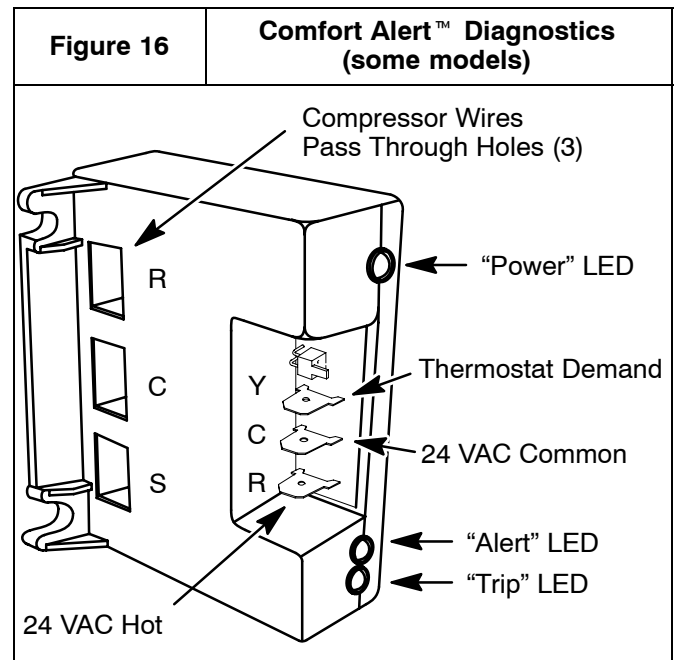

MAINTENANCE

Condensate Drain

During the cooling season, check monthly for free flow of drainage and clean if necessary.

Cleanliness

These tips will help keep the air conditioner looking better and working more efficiently:

1. Free flow of air is essential. Keep fences, shrubs, trash cans, and other obstructions at least 18 inches from all coil inlets.

2. Keep the coil free of grass clippings, leaves, weeds, and other debris.

NOTE: Coil may occasionally require cleaning with a liquid solution. The coil must be cold when cleaning. Use an alkaline based cleaner only. Cleaning a hot coil or using an acid based cleaner will remove the paint from the fins and may clog the coil.

3. Never use a weather cover over the outdoor unit unless it is a ventilated type or made of breathable fabric that will allow moisture to evaporate rapidly. A cover that holds moisture in the unit will cause more rust build-up and damage than normal exposure to weather.

Figure 17		Comfort Alert™ Diagnostics (some models)	
Status LED	Status LED Description	Status LED Troubleshooting Information	
Green “POWER”	Module has power	Supply voltage is present at module terminals	
Red “TRIP”	Thermostat demand signal Y1 is present, but the compressor is not running	<ol style="list-style-type: none"> 1. Compressor protector is open 2. Outdoor unit power disconnect is open 3. Compressor circuit breaker or fuse(s) is open 4. Broken wire or connector is not making contact 5. Low pressure switch open if present in system 6. Compressor contactor has failed open 	
Yellow “ALERT” Flash Code 1	Long Run Time Compressor is running extremely long run cycles	<ol style="list-style-type: none"> 1. Low refrigerant charge 2. Evaporator blower is not running 3. Evaporator coil is frozen 4. Faulty metering device 5. Condenser coil is dirty 6. Liquid line restriction (filter drier blocked if present in system) 7. Thermostat is malfunctioning 	
Yellow “ALERT” Flash Code 2	System Pressure Trip Discharge or suction pressure out of limits or compressor overloaded	<ol style="list-style-type: none"> 1. High head pressure 2. Condenser coil poor air circulation (dirty, blocked, damaged) 3. Condenser fan is not running 4. Return air duct has substantial leakage 5. If low pressure switch present in system, check Flash Code 1 information 	
Yellow “ALERT” Flash Code 3	Short Cycling Compressor is running only briefly	<ol style="list-style-type: none"> 1. Thermostat demand signal is intermittent 2. Time delay relay or control board defective 3. If high pressure switch present go to Flash Code 2 information 4. If low pressure switch present go to Flash Code 1 information 	
Yellow “ALERT” Flash Code 4	Locked Rotor	<ol style="list-style-type: none"> 1. Run capacitor has failed 2. Low line voltage (contact utility if voltage at disconnect is low) 3. Excessive liquid refrigerant in compressor 4. Compressor bearings are seized 	
Yellow “ALERT” Flash Code 5	Open Circuit	<ol style="list-style-type: none"> 1. Outdoor unit power disconnect is open 2. Compressor circuit breaker or fuse(s) is open 3. Compressor contactor has failed open 4. High pressure switch is open and requires manual reset 5. Open circuit in compressor supply wiring or connections 6. Unusually long compressor protector reset time due to extreme ambient temperature 7. Compressor windings are damaged 	
Yellow “ALERT” Flash Code 6	Open Start Circuit Current only in run circuit	<ol style="list-style-type: none"> 1. Run capacitor has failed 2. Open circuit in compressor start wiring or connections 3. Compressor start winding is damaged 	
Yellow “ALERT” Flash Code 7	Open Run Circuit Current only in start circuit	<ol style="list-style-type: none"> 1. Open circuit in compressor run wiring or connections 2. Compressor run winding is damaged 	
Yellow “ALERT” Flash Code 8	Welded Contactor Compressor always runs	<ol style="list-style-type: none"> 1. Compressor contactor has failed closed 2. Thermostat demand signal not connected to module 	
Yellow “ALERT” Flash Code 9	Low Voltage Control circuit < 17VAC	<ol style="list-style-type: none"> 1. Control circuit transformer is overloaded 2. Low line voltage (contact utility if voltage at disconnect is low) 	

- Flash Code number corresponds to a number of LED flashes, followed by a pause and then repeated.
- TRIP and ALERT LEDs flashing at same time means control circuit voltage is too low for operation.
- Reset ALERT Flash code by removing 24VAC power from module.
- Last ALERT Flash code is displayed for 1 minute after module is powered on.