

INSTALLATION INSTRUCTIONS

R-410A Split System Air Conditioner

CSA6, HSA6, TSA6

These instructions must be read and understood completely before attempting installation.

Safety Labeling and Signal Words

DANGER, WARNING, CAUTION, and NOTE

The signal words **DANGER**, **WARNING**, **CAUTION**, and **NOTE** are used to identify levels of hazard seriousness. The signal word **DANGER** is only used on product labels to signify an immediate hazard. The signal words **WARNING**, **CAUTION**, and **NOTE** will be used on product labels and throughout this manual and other manuals that may apply to the product.

DANGER – Immediate hazards which **will** result in severe personal injury or death.

WARNING – Hazards or unsafe practices which **could** result in severe personal injury or death.

CAUTION – Hazards or unsafe practices which **may** result in minor personal injury or product or property damage.

NOTE – Used to highlight suggestions which **will** result in enhanced installation, reliability, or operation.

Signal Words in Manuals

The signal word **WARNING** is used throughout this manual in the following manner:



The signal word **CAUTION** is used throughout this manual in the following manner:



Signal Words on Product Labeling

Signal words are used in combination with colors and/or pictures on product labels.

TABLE OF CONTENTS

Safety Considerations	2
Installation Requirements	2
Installation	2
Start-up Procedure	7
General Sequence of Operation	8
Control Functions & Sequence of Operation	8
Troubleshooting	9
Status Codes	10



ELECTRICAL SHOCK HAZARD

Failure to follow this warning could result in personal injury and/or death.

Before installing, modifying, or servicing system, main electrical disconnect switch must be in the OFF position. There may be more than 1 disconnect switch. Lock out and tag switch with a suitable warning label.



CUT HAZARD

Failure to follow this caution may result in personal injury

Sheet metal parts may have sharp edges or burrs. Use care and wear appropriate protective clothing and gloves when handling parts.

SAFETY CONSIDERATIONS

Improper installation, adjustment, alteration, service, maintenance, or use can cause explosion, fire, electrical shock, or other conditions which may cause death, personal injury, or property damage. Consult a qualified installer, service agency, or your distributor or branch for information or assistance. The qualified installer or agency must use factory-authorized kits or accessories when modifying this product. Refer to the individual instructions packaged with the kits or accessories when installing.

Follow all safety codes. Wear safety glasses, protective clothing, and work gloves. Use quenching cloth for brazing operations. Have fire extinguisher available. Read these instructions thoroughly and follow all warnings or cautions included in literature and attached to the unit. Consult local building codes and current editions of the National Electrical Code (NEC) NFPA 70. In Canada, refer to current editions of the Canadian electrical code CSA 22.1.

Recognize safety information. This is the safety-alert symbol

⚠ When you see this symbol on the unit and in instructions or manuals, be alert to the potential for personal injury. Understand these signal words; DANGER, WARNING, and CAUTION. These words are used with the safety-alert symbol. DANGER identifies the most serious hazards which will result in severe personal injury or death. WARNING signifies hazards which could result in personal injury or death. CAUTION is used to identify unsafe practices which would result in minor personal injury or product and property damage. NOTE is used to highlight suggestions which will result in enhanced installation, reliability, or operation.

INSTALLATION RECOMMENDATIONS

NOTE: In some cases noise in the living area has been traced to gas pulsations from improper installation of equipment.

1. Locate unit away from windows, patios, decks, etc. where unit operation sound may disturb customer.
2. Ensure that vapor and liquid tube diameters are appropriate for unit capacity.
3. Run refrigerant tubes as directly as possible by avoiding unnecessary turns and bends.
4. Leave some slack between structure and unit to absorb vibration.
5. When passing refrigerant tubes through the wall, seal opening with RTV or other pliable silicon-based caulk. (See Fig. 1.)
6. Avoid direct tubing contact with water pipes, duct work, floor joists, wall studs, floors, and walls.
7. Do not suspend refrigerant tubing from joists and studs with a rigid wire or strap which comes in direct contact with tubing. (See Fig. 1.)
8. Ensure that tubing insulation is pliable and completely surrounds vapor tube.
9. When necessary, use hanger straps which are 1 in. (25.4 mm) wide and conform to shape of tubing insulation. (See Fig. 1.)
10. Isolate hanger straps from insulation by using metal sleeves bent to conform to shape of insulation.

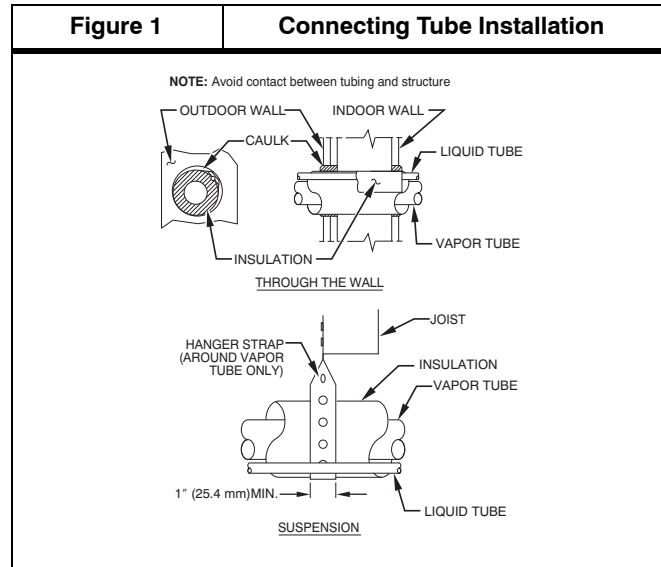

Outdoor unit contains system refrigerant charge for operation with AHRI rated indoor unit when connected by 15 ft. (4.57 m) of field-supplied or factory accessory tubing. For proper unit operation, check refrigerant charge using charging information located on control box cover and/or in the Check Charge section of this instruction.

IMPORTANT: Maximum liquid-line size is 3/8-in. OD for all residential applications including long line.

IMPORTANT: Always install the factory-supplied liquid-line filter drier. Obtain replacement filter driers from your distributor or branch.

INSTALLATION

⚠ WARNING

UNIT OPERATION AND SAFETY HAZARD

Failure to follow this warning could result in personal injury or equipment damage.

R-410A refrigerant systems operate at higher pressures than standard R-22 systems. Do not use R-22 service equipment or components on R-410A refrigerant equipment.

Specifications for this unit in residential new construction market require the outdoor unit, indoor unit, refrigerant tubing sets, metering device, and filter drier listed in presale literature. There can be no deviation.

Check Equipment and Job Site

Unpack Unit

Move to final location. Remove carton taking care not to damage unit.

Inspect Equipment

File claim with shipping company prior to installation if shipment is damaged or incomplete. Locate unit rating plate on unit corner panel. It contains information needed to properly install unit. Check rating plate to be sure unit matches job specifications.

Install on a Solid, Level Mounting Pad

If conditions or local codes require the unit be attached to pad, tie down bolts should be used and fastened through knockouts provided in unit base pan. Refer to unit mounting pattern in Fig. 2 to determine base pan size and knockout hole location.

For hurricane tie downs – contact your local distributor for details and PE (Professional Certification), if required by local authorities.

On rooftop applications, mount on level platform or frame. Place unit above a load-bearing wall and isolate unit and tubing set from structure. Arrange supporting members to adequately support unit and minimize transmission of vibration to building. Consult local codes governing rooftop applications.

Roof mounted units exposed to winds may require wind baffles. Consult the Low-Ambient pressure switch installation instructions for wind baffle construction.

NOTE: Unit must be level to within $\pm 2^\circ$ ($\pm 3/8$ in./ft..) per compressor manufacturer specifications.

Clearance Requirements

When installing, allow sufficient space for airflow clearance, wiring, refrigerant piping, and service. Allow 30 in. (762 mm) clearance to service end of unit and 48 in. (1219.2 mm) above unit. For proper airflow, a 6 in. (152.4 mm) clearance on one side of unit and 12 in. (304.8 mm) on all remaining sides must be maintained. Maintain a distance of 24 in. (609.6 mm) between units. Position so water, snow, or ice from roof or eaves cannot fall directly on unit.

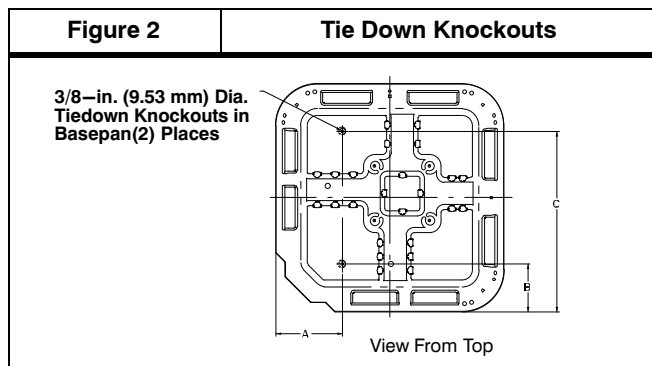

UNIT BASE PAN Dimension	TIEDOWN KNOCKOUT LOCATIONS in. (mm)		
	A	B	C
31-1/2 X 31-1/2	9-1/8 (231.8)	6-9/16 (166.7)	24-11/16 (627.1)
35 X 35	9-1/8 (231.8)	6-9/16 (166.7)	28-7/16 (722.3)

On rooftop applications, locate unit at least 6 in. (152.4 mm) above roof surface.

Operating Ambient

The minimum outdoor operating ambient in cooling mode is 55°F (12.78°C) without low ambient cooling enabled, and the maximum outdoor operating ambient in cooling mode is 125°F (51.67°C).

Make Piping Connections

⚠ WARNING

PERSONAL INJURY AND ENVIRONMENTAL HAZARD

Failure to follow this warning could result in personal injury or death.

Relieve pressure and recover all refrigerant before system repair or final unit disposal.

Use all service ports and open all flow-control devices, including solenoid valves.

⚠ CAUTION

UNIT DAMAGE HAZARD

Failure to follow this caution may result in equipment damage or improper operation.

Do not leave system open to atmosphere any longer than minimum required for installation. POE oil in compressor is extremely susceptible to moisture absorption. Always keep ends of tubing sealed during installation.

If ANY refrigerant tubing is buried, provide a 6 in. (152.4 mm) vertical rise at service valve. Refrigerant tubing lengths up to 36 in. (914.4 mm) may be buried without further special consideration. Do not bury lines more than 36 in. (914.4 mm).

Outdoor units may be connected to indoor section using accessory tubing package or field-supplied refrigerant grade tubing of correct size and condition. For tubing requirements beyond 80 ft/24.38 m, substantial capacity and performance losses can occur. Following the recommendations in the Long Line Applications Guideline for Split-System Air Conditioners and Heat Pumps will reduce these losses. Refer to Table 1 for accessory requirements. Refer to Table 2 for field tubing diameters.

There are no buried-line applications greater than 36 in. (914.4 mm).

If refrigerant tubes or indoor coil are exposed to atmosphere, they must be evacuated to 500 microns to eliminate contamination and moisture in the system.

Outdoor Unit Connected to Factory Approved Indoor Unit

Outdoor unit contains correct system refrigerant charge for operation with factory approved AHRI rated indoor unit when connected by 15 ft. (4.57 m) of field-supplied or factory-accessory tubing, and factory supplied filter drier. Check refrigerant charge for maximum efficiency.

Table 1 – Accessory Usage

Accessory	REQUIRED FOR LOW-AMBIENT COOLING APPLICATIONS (Below 55°F / 12.8°C)	REQUIRED FOR LONG LINE APPLICATIONS* (Over 80 ft. / 24.38 m)
Crankcase Heater	Yes	Yes
Compressor Start Assist Capacitor and Relay	Yes	Yes
Evaporator Freeze Thermostat	Yes	No
Liquid Line Solenoid Valve	No	See Long Line Applications Guideline
Low-ambient Pressure Switch	Yes	No
Support Feet	Recommended	No
Thermal Expansion Valve (TXV) Hard Shutoff	Yes	Yes
Winter Start Control	Yes	No

* For tubing line sets between 80 and 200 ft. (24.38 and 60.96 m) and/or 20 ft. (6.09 m) vertical differential, refer to Long Line Applications Guideline.

Table 2 – Refrigerant Connections and Recommended Liquid and Vapor Tube Diameters (In.)

UNIT SIZE	LIQUID	RATED VAPOR up to 80 ft. (24.38 m)*	
	Connection and Tube Diameter	Connection Diameter	Rated Tube Diameter
18, 24, 30,	3/8	3/4	3/4
36, 42, 48	3/8	7/8	7/8
60	3/8	7/8	1-1/8

* Units are rated with 25 ft. (7.6 m) of lineset. See Specification sheet for performance data when using different size and length linesets.

Notes:

1. Do not apply capillary tube or fixed orifice indoor coils to these units.
2. For Tubing Set lengths between 80 and 200 ft. (24.38 and 60.96 m) horizontal or 35 ft. (10.7 m) vertical differential 250 ft. (76.2 m) Total Equivalent Length), refer to the Long Line Applications Guideline.



Use of the AHRI Certified TM Mark indicates a manufacturer's participation in the program. For verification of certification for individual products, go to www.ahridirectory.org.



This product has been designed and manufactured to meet Energy Star® criteria for energy efficiency when matched with appropriate coil components. However, proper refrigerant charge and proper air flow are critical to achieve rated capacity and efficiency. Installation of this product should follow all manufacturing refrigerant charging and air flow instructions. **Failure to confirm proper charge and air flow may reduce energy efficiency and shorten equipment life.**

Install Liquid Line Filter Drier Indoor

⚠ CAUTION

UNIT DAMAGE HAZARD

Failure to follow this caution may result in equipment damage or improper operation.

Installation of filter drier in liquid line is required. Filter drier must be wrapped in a heat-sinking material such as a wet cloth while brazing.

Refer to Fig. 3 and install filter drier as follows:

1. Braze 5 in. (127 mm) liquid tube to the indoor coil.
2. Wrap filter drier with damp cloth.
3. Braze filter drier to above 5 in. (127 mm) liquid tube. Flow arrow must point towards indoor coil.
4. Connect and braze liquid refrigerant tube to the filter drier.

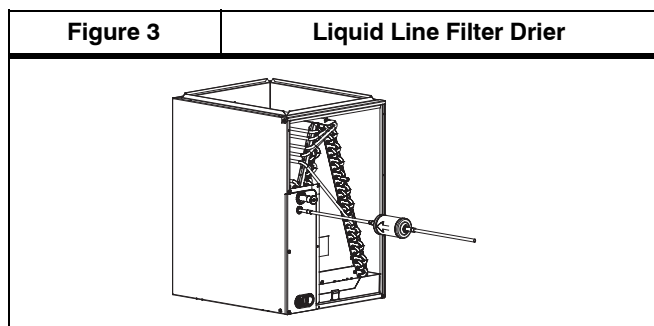

Refrigerant Tubing Connection Outdoor

Connect vapor tube to fitting on outdoor unit vapor service valves (see Table 2.) Connect and braze the 3/8" coupling (provided with the filter drier) to the liquid service valve and connect and braze the liquid tubing to the other end of this coupling. Use refrigerant grade tubing.

Sweat Connection

⚠ CAUTION

UNIT DAMAGE HAZARD

Failure to follow this caution may result in equipment damage or improper operation.

Service valves must be wrapped in a heat-sinking material such as a wet cloth.

Service valves are closed from factory and ready for brazing. After wrapping service valve with a wet cloth, braze sweat connections using industry accepted methods and materials. Consult local code requirements. Refrigerant tubing and indoor coil are now ready for leak testing. This check should include all field and factory joints.

Evacuate Refrigerant Tubing and Indoor Coil

⚠ CAUTION

UNIT DAMAGE HAZARD

Failure to follow this caution may result in equipment damage or improper operation.

Never use the system compressor as a vacuum pump.

Refrigerant tubes and indoor coil should be evacuated using the recommended deep vacuum method of 500 microns. An alternate triple evacuation method may be used. See triple evacuation method in Service Manual.

IMPORTANT: Always break a vacuum with dry nitrogen.

Deep Vacuum Method

The deep vacuum method requires a vacuum pump capable of pulling a vacuum of 500 microns and a vacuum gage capable of accurately measuring this vacuum depth. The deep vacuum method is the most positive way of assuring a system is free of air and liquid water. (See Fig. 4)

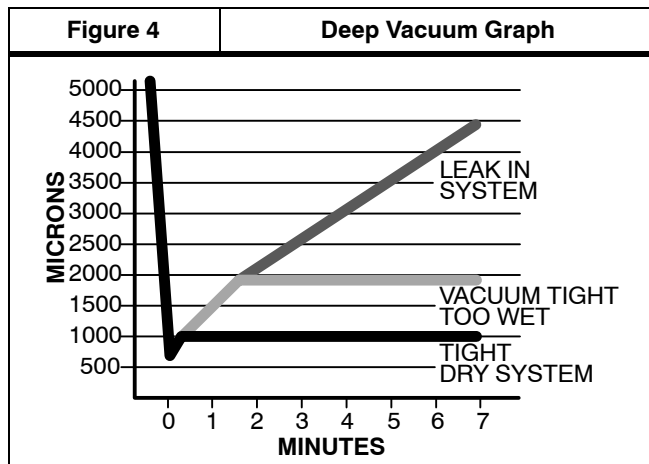

Final Tubing Check

IMPORTANT: Check to be certain factory tubing on both indoor and outdoor unit has not shifted during shipment. Ensure tubes are not rubbing against each other or any sheet metal. Pay close attention to feeder tubes, making sure wire ties on feeder tubes are secure and tight.

Make Electrical Connections

⚠ WARNING

ELECTRICAL SHOCK HAZARD

Failure to follow this warning could result in personal injury or death.

Do not supply power to unit with compressor terminal box cover removed.

Be sure field wiring complies with local and national fire, safety, and electrical codes, and voltage to system is within limits shown on unit rating plate. Contact local power company for correction of improper voltage. See unit rating plate for recommended circuit protection device.

NOTE: Operation of unit on improper line voltage constitutes abuse and could affect unit reliability. See unit rating plate. Do not install unit in system where voltage may fluctuate above or below permissible limits.

NOTE: Use copper wire only between disconnect switch and unit.

NOTE: Install branch circuit disconnect of adequate size per NEC to handle unit starting current. Locate disconnect within sight from and readily accessible from unit, per Section 440-14 of NEC.

Route Ground and Power Wires

Remove access panel to gain access to unit wiring. Extend wires from disconnect through power wiring hole provided and into unit control box.



WARNING

ELECTRICAL SHOCK HAZARD

Failure to follow this warning could result in personal injury or death.

The unit cabinet must have an uninterrupted or unbroken ground to minimize personal injury if an electrical fault should occur. The ground may consist of electrical wire or metal conduit when installed in accordance with existing electrical codes.

Connect Ground and Power Wires

Connect ground wire to ground connection in control box for safety. Connect power wiring to contactor as shown in Fig. 5.

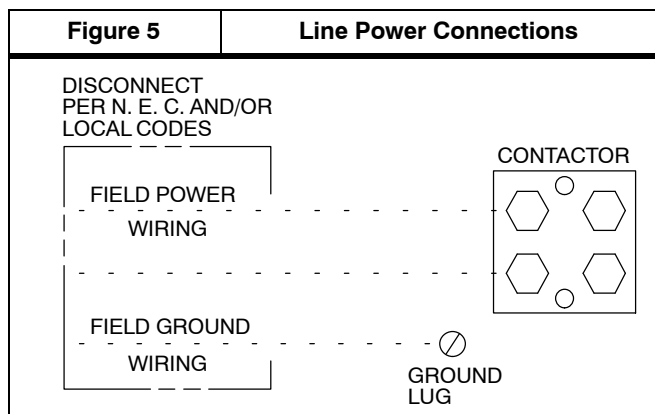

Connect Control Wiring

Route 24-v control wires through control wiring grommet and connect leads to control wiring. (See Fig. 10 & Fig. 11)

Use No. 18 AWG color-coded, insulated (35°C minimum) wire. If thermostat is located more than 100 ft. (30.48 m) from unit, as measured along the control voltage wires, use No. 16 AWG color-coded, insulated wire to avoid excessive voltage drop.

All wiring must be NEC Class 1 and must be separated from incoming power leads.

Use furnace transformer, fan coil transformer, or accessory transformer for control power, 24-v/40-va minimum.

NOTE: Use of available 24-v accessories may exceed the minimum 40-va power requirement. Determine total transformer load and increase the transformer capacity or split the load with an accessory transformer as required.

Final Wiring Check

IMPORTANT: Check factory wiring and field wire connections to ensure terminations are secured properly. Check wire routing to ensure wires are not in contact with tubing, sheet metal, etc.

Compressor Crankcase Heater

When equipped with a crankcase heater, furnish power to heater a minimum of 24 hr before starting unit. To furnish power to heater only, set thermostat to OFF and close electrical disconnect to outdoor unit.

A crankcase heater is required for low-ambient cooling or if refrigerant tubing is longer than 80 ft. (24.38 m). Refer to the Long Line Applications Guideline – Residential Split-System Air Conditioners and Heat Pumps Using R-410A Refrigerant.

Install Electrical Accessories

Refer to the individual instructions packaged with kits or accessories when installing.

Check OAT Thermistor and OCT Thermistor Attachments

Outdoor Air Temperature (OAT) Thermistor is factory installed by inserting the nibs on either sides of the thermistor body through a keyhole in the bottom shelf of the control box and locking it in place by turning it 90 degrees, such that the spherical end of a nib faces the front of the control box.

Check to make sure the OAT is locked in place. See Fig. 6.

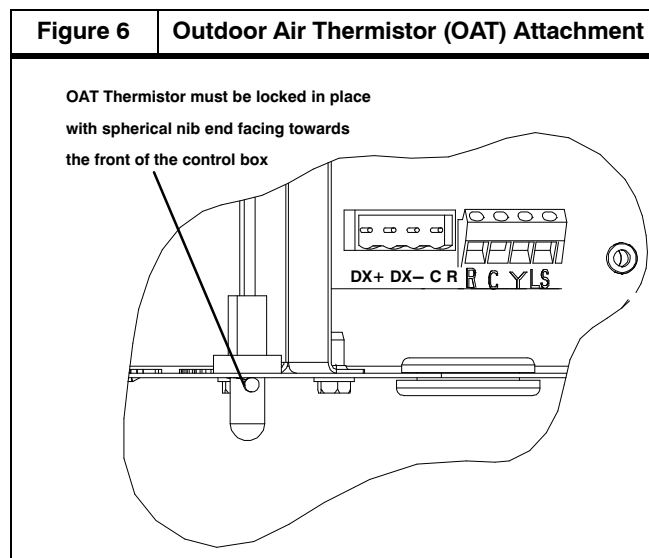

The Outdoor Coil Temperature (OCT) Thermistor is factory installed on the liquid tube between the coil assembly and the liquid service valve. See Fig. 7.

Check to make sure the thermistor is securely attached on the liquid tube with the clip as shown in Fig. 7.

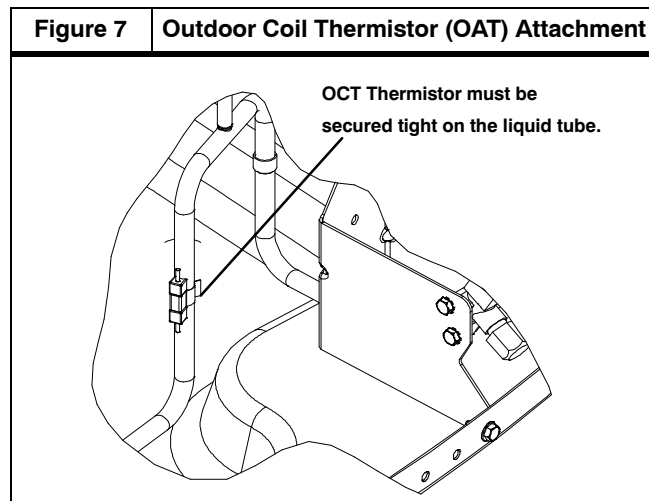

Start-Up

 **CAUTION**

UNIT OPERATION AND SAFETY HAZARD

Failure to follow this caution may result in minor personal injury, equipment damage or improper operation.

To prevent compressor damage or personal injury, observe the following:

- Do not overcharge system with refrigerant.
- Do not operate unit in a vacuum or at negative pressure.
- Do not disable low pressure switch in scroll compressor applications.
- Dome temperatures may be hot.

 **CAUTION**

PERSONAL INJURY HAZARD

Failure to follow this caution may result in personal injury.

Wear safety glasses, protective clothing, and gloves when handling refrigerant and observe the following:

- Front seating service valves are equipped with Schrader valves.

 **CAUTION**

ENVIRONMENTAL HAZARD

Failure to follow this caution may result in environmental damage.

Federal regulations require that you do not vent refrigerant to the atmosphere. Recover during system repair or final unit disposal.

Follow these steps to properly start up the system:

1. After system is evacuated, fully open liquid and vapor service valves.
2. Unit is shipped with valve stem(s) front seated (closed) and caps installed.
Replace stem caps after system is opened to refrigerant flow. Replace caps finger-tight and tighten with wrench an additional 1/12 turn
3. Close electrical disconnects to energize system.
4. Set room thermostat at desired temperature. Be sure set point is below indoor ambient temperature.
5. Set room thermostat to COOL and fan control to ON or AUTO mode, as desired. Operate unit for 15 minutes. Check system refrigerant charge.

Check Charge

Factory charge amount and desired subcooling are shown on unit rating plate. Charging method is shown on information plate inside unit. To properly check or adjust charge, conditions must be favorable for subcooling charging. Favorable conditions exist when the outdoor temperature is between 70°F and 100°F (21.11°C and 37.78°C), and the indoor temperature is between 70°F and 80°F (21.11°C and 26.67°C). Follow the procedure below:

Unit is factory charged for 15ft (4.57 m) of lineset. Adjust charge by adding or removing 0.6 oz/ft of 3/8 liquid line above or below 15ft (4.57 m) respectively.

For standard refrigerant line lengths (80 ft/24.38 m or less), allow system to operate in cooling mode at least 15 minutes. When operating with the Observer Wall Control in communicating mode, make sure that indoor airflow is set to "efficiency" during charging. If conditions are favorable, check system charge by subcooling method. If any adjustment is necessary, adjust charge slowly and allow system to operate for 15 minutes to stabilize before declaring a properly charged system.

If the indoor temperature is above 80°F (26.67°C), and the outdoor temperature is in the favorable range, adjust system charge by weight based on line length and allow the indoor temperature to drop to 80°F (26.67°C) before attempting to check system charge by subcooling method as described above.

If the indoor temperature is below 70°F (21.11°C), or the outdoor temperature is not in the favorable range, adjust charge for line set length above or below 15ft (4.57 m) only. Charge level should then be appropriate for the system to achieve rated capacity. The charge level could then be checked at another time when the both indoor and outdoor temperatures are in a more favorable range.

NOTE: If line length is beyond 80 ft (24.38 m) or greater than 20 ft (6.10 m) vertical separation, See Long Line Applications Guideline for special charging requirements.

Major Components

Control Board

The AC control board controls the following functions:

- Compressor contactor operation
- Outdoor fan motor operation
- Compressor external protection
- Pressure switch monitoring
- Time Delays

Field Connections

When using communicating control, 4 field wires are required to be connected to the factory wires already wired to the DX+DX-C R terminal (see Fig. 10). Unit as provided by manufacturer is set up for communicating control.

When used with a standard non-communicating thermostat, it is recommended to use 3 thermostat control wires to be connected to R, Y and C. When using 3 wires, all diagnostic and time delay features are enabled (See Fig. 11). Disconnect factory provided wires from DX+, DX-, C & R terminals. Using factory provided wires, connect to R, C, and Y on the control board for 3 wire thermostat control. Connect field 24V wires to factory provided wires now connected to R, C, and Y and cap both sides or remove unused factory provided wires.

When only 2 thermostat control wires are available, units will function, but some control features are lost. (See Fig. 12). With only 2 wires connected, the circuit board will be powered down whenever there is no call for cooling, and the following will result:

- Compressor time delay is reduced from 5 minutes to 10 seconds
- When the thermostat is not calling for cooling, the amber status light will be off, and no diagnostics codes will be available
- All system counters will be reset on each new call for cooling

Disconnect factory provided wires from DX+, DX-, C and R terminals. Using factory provided wires, connect to C and Y on the control board for 2 wire thermostat control. A field installed jumper wire is also required between R and Y (See Fig. 12). Connect field 24V wires to factory provided wires now connected to C and Y and cap both sides or remove unused factory provided wires.

Compressor Internal Relief

The compressor is protected by an Internal Pressure Relief (IPR) which relieves discharge gas into the compressor shell when differential between suction and discharge pressure exceeds 550–625 psi. The compressor is also protected by an internal overload attached to motor windings.

GENERAL SEQUENCE OF OPERATION STANDARD THERMOSTAT

Turn on power to indoor and outdoor units. Transformer is energized.

On a call for cooling, thermostat makes circuits R–Y and R–G. Circuit R–Y energizes contactor, starting outdoor fan motor and compressor circuit. R–G energizes indoor unit blower relay, starting indoor blower motor on high speed.

NOTE: To achieve the rated system performance, the indoor unit or the thermostat must be equipped with a time delay relay circuit.

When thermostat is satisfied, its contacts open, de-energizing contactor and blower relay. Compressor and motors stop. If indoor unit is equipped with a time-delay relay circuit, the indoor blower will run an additional 90 sec to increase system efficiency.

CONTROL FUNCTIONS AND SEQUENCE OF OPERATION

The outdoor unit control system has special functions. The following is an overview of the control functions.

SEQUENCE OF OPERATION

Cooling Operation

This product utilizes either a standard indoor thermostat or Observer™ Communicating Wall Control. With a call for cooling, the outdoor fan and compressor are energized. When the cooling demand is satisfied, the compressor and fan will shut off.

NOTE: The outdoor fan motor will continue to operate for one minute after compressor shuts off, when the outdoor ambient is greater than or equal to 100°F (37.78°C).

Communication and Status Function Lights

Green Communications (COMM) Light (Communicating Control only):

A green LED (COMM light) on the outdoor board indicates successful communication with the other system products. The green LED will remain OFF until communications is established. Once a valid command is received, the green LED will turn ON continuously. If no communication is received within 2 minutes, the LED will be turned OFF until the next valid communication.

Amber Status Light

An amber colored STATUS light is used to display the operation mode and fault codes as specified in the troubleshooting section. See Table 3 for codes and definitions.

NOTE: Only one fault code will be displayed on the outdoor unit control board (the most recent, with the highest priority).

Crankcase Heater Operation

The crankcase heater (when applicable) is energized during the off cycle below 65°F (37.78°C)

Outdoor Fan motor Operation

The outdoor unit control energizes outdoor fan any time the compressor is operating. The outdoor fan remains energized for 15 minutes if a pressure switch or compressor thermal protector should open. Outdoor fan motor will continue to operate for one minute after the compressor shuts off when the outdoor ambient is greater than or equal to 100°F (37.78°C).

Time Delays

The unit time delays include:

- Five minute time delay to start cooling operation when there is a call from the thermostat or communicating wall control.
- When operating the unit with 2 wires, this delay is shortened to 10 seconds.
- Five minute compressor recycle delay on return from a brown out condition
- Two minute time delay to return to standby operation from last valid communications (with communicating only)
- One minute time delay of outdoor fan at termination of cooling mode when outdoor ambient is greater than or equal to 100°F (37.78°C).

Utility Interface

With Non-Communicating Thermostats

Utility curtailment will only work when the unit is operating with a non-communicating thermostat.

When the utility curtailment interface is applied with a non-communicating thermostat, the utility relay should be wired in series with the Y input.

Low Ambient Cooling

When this unit is required to operate below 55°F (12.78°C) to a minimum of 0°F (-17.78°C) outdoor temperature, provisions must be made for low ambient operation.

Low ambient applications **require** the installation of accessory kits:

- Low Ambient Pressure Switch Kit
- Evaporator Freeze Thermostat
- Hard Start kit
- Crankcase Heater

Support feet are recommended for low ambient cooling. See Product Specification sheet for kit part numbers on appropriate unit size and series unit.

For low ambient cooling with the Observer Communicating Wall Control the cooling lockout must be set to “Off” in the Wall Control setup.

Liquid Line Solenoid

When operating in communicating mode the standard thermostat terminals will not function. A terminal on the non-communicating thermostat bus labeled “LS” on the AC control board is provided for wiring liquid line solenoids when in communicating mode. For operation in communicating mode wire solenoid valve kit NASA401LS across LS and C terminals. For operation in non-communicating mode wire solenoid valve kit NASA401LS across C and Y terminals.

TROUBLESHOOTING

SYSTEMS COMMUNICATION FAILURE

If communication between outdoor unit, control board, and indoor wall control has failed, the control will flash the appropriate fault code. (See table 3) Check the wiring to the wall control, indoor and outdoor units.

PRESSURE SWITCH PROTECTION

The outdoor unit is equipped with high- and low-pressure switches. If the control senses the opening of a high or low-pressure switch, it will de-energize the compressor contactor, keep the outdoor fan operating for 15 minutes and display the appropriate fault code. (See table 3)

After a 15 minute delay, if there is still a call for cooling, and the LPS or HPS is reset, the compressor contactor is energized. If the LPS or HPS has not closed after a 15 minute delay, the outdoor fan is turned off. If the open switch closes anytime after the 15-minute delay, then the unit will resume operation with a call for cooling.

If the LPS or HPS trips for five consecutive cycles, then unit operation is locked out for 4 hours and the appropriate fault code (See table 3) is displayed.

In the event of a high-pressure switch trip or high-pressure lockout, check the refrigerant charge, outdoor fan operation and outdoor coil for airflow restrictions.

In the event of a low-pressure switch trip or low-pressure lockout, check the refrigerant charge and indoor airflow.

CONTROL FAULT

If the outdoor unit control board has failed, the control will flash the appropriate fault code. (See table 3) The control board should be replaced.

24V BROWN OUT PROTECTION

If the control voltage is less than 15.5volts for at least 4 seconds, the compressor contactor and fan relay are de-energized. Compressor and fan operation are not allowed until control voltage is a minimum of 17.5volts. The control will flash the appropriate fault code. (See table 3) Verify the control voltage is in the allowable range of 18-30volts.

COMPRESSOR VOLTAGE SENSING

The input terminals labeled VR and VS on the control board (see Fig. 9) are used to detect compressor voltage status, and alert the user of potential problems. The control continuously monitors the high voltage on the run capacitor of the compressor motor. Voltage should be present any time the compressor contactor is energized, and voltage should not be present when the contactor is de-energized.

COMPRESSOR THERMAL CUTOUT OR LOSS OF 230V POWER

If the control senses the compressor voltage after start-up, and is then absent for 10 consecutive seconds while cooling demand exists, it will de-energize the compressor contactor, keep the outdoor fan operating for 15 minutes (if 230v power present) and display the appropriate fault code. (See table 3) Possible causes are compressor internal overload trip or loss of high voltage (230V) to compressor without loss of control voltage.

After a 15 minute delay, if there is still a call for cooling, the compressor contactor is energized. If the thermal protector has not re-set, the outdoor fan is turned off. If the call for cooling continues, the control will energize the compressor contactor every 15 minutes. If the thermal protector closes, (at the next 15 minute interval check), the unit will resume operation.

If the thermal cutout trips for three consecutive cycles, then unit operation is locked out for 4 hours and the appropriate fault code (See Table 3) is displayed.

CONTACTOR SHORTED DETECTION

If there is compressor voltage sensed when there is no demand for compressor operation, the contactor may be stuck closed. The control will flash the appropriate fault code. Check the contactor and control box wiring.

NO 230V AT COMPRESSOR

If the compressor voltage is not sensed when the compressor should be starting, the contactor may be stuck open or the unit disconnect or circuit breaker may be open. The control will flash the appropriate fault code. Check the contactor, unit disconnect or circuit breaker and control box wiring.

TEMPERATURE THERMISTORS

Thermistors are electronic devices which sense temperature. As the temperature increases, the resistance decreases. Thermistors are used to sense outdoor air (OAT) and coil temperature (OCT).

If the outdoor air or coil thermistor should fail, the control will flash the appropriate fault code. (See table 3).

IMPORTANT: The outdoor air thermistor and coil thermistor are factory mounted in the correct locations. Do not re-locate thermistor sensors.

THERMISTOR SENSOR COMPARISON

The control continuously monitors and compares the outdoor air temperature sensor and outdoor coil temperature sensor to ensure proper operating conditions. The comparison is, if the outdoor air sensor indicates $\geq 10^{\circ}\text{F}$ ($\geq -12.22^{\circ}\text{C}$) warmer than the coil sensor (or) the outdoor air sensor indicates $\geq 20^{\circ}\text{F}$ ($\geq -6.67^{\circ}\text{C}$) cooler than the coil sensor, the sensors are out of range.

If the sensors are out of range, the control will flash the appropriate fault code. (See Table 3).

FAILED THERMISTOR DEFAULT OPERATION

Factory defaults have been provided in the event of failure of outdoor air thermistor and/or coil thermistor.

Thermistor Curve: The resistance vs. temperature chart shown in Figure 8 enables the technician to check the outdoor air and outdoor coil thermistors for proper resistance. Unplug the thermistor assembly from the circuit board and measure resistance across each thermistor. For example, if the outdoor temperature is 60°F (15.56°C), the resistance reading across the outdoor air thermistor should be around 16,000 Ohms.

STATUS CODES

Table 3 shows the status codes flashed by the amber status light. Most system problems can be diagnosed by reading the status code as flashed by the amber status light on the control board.

The codes are flashed by a series of short and long flashes of the status light. The short flashes indicate the first digit in the status code, followed by long flashes indicating the second digit of the error code. The short flash is 0.25 second ON and the long flash is 1.0 second ON. Time between flashes is 0.25 second. Time between short flash and first long flash is 1.0 second. Time between code repeating is 2.5 seconds with LED OFF.

Count the number of short and long flashes to determine the appropriate flash code. Table 3 gives possible causes and actions related to each error.

Example: 3 short flashes followed by 2 long flashes indicates a 32 code. Table 3 shows this to be low pressure switch open.

Table 3 – Status Codes

OPERATION	FAULT	AMBER LED FLASH CODE	Possible Cause and Action
Standby – no call for unit operation	None	On solid, no flash	Normal operation – with communicating Control
Standby – no call for unit operation	None	Off	Normal operation – No call for cooling with 2-wire connection or indoor unit not powered.
Cooling Operation	None	1, pause	Normal operation
	System Communications Failure	16	Communication with wall control lost. Check wiring to wall control, indoor and outdoor units
	High Pressure Switch Open	31	High pressure switch trip. Check refrigerant charge, outdoor fan operation and coils for airflow restrictions.
	Low Pressure Switch Open	32	Low pressure switch trip. Check refrigerant charge and indoor air flow
	Control Fault	45	Outdoor unit control board has failed. Control board needs to be replaced.
	Brown Out (24 v)	46	The control voltage is less than 15.5v for at least 4 seconds. Compressor and fan operation not allowed until control voltage is a minimum of 17.5v. Verify control voltage.
	Outdoor Air Temp Sensor Fault	53	Outdoor air sensor not reading or out of range. Ohm out sensor and check wiring
	Outdoor Coil Sensor Fault	55	Coil sensor not reading or out of range. Ohm out sensor and check wiring
	Thermistors out of range	56	Improper relationship between coil sensor and outdoor air sensor. Ohm out sensors and check wiring.
	Thermal Cutout	72	Compressor voltage sensed after start-up, then absent for 10 consecutive seconds while cooling demand exists. Possible causes are internal compressor overload trip or loss of high voltage to compressor without loss of control voltage. The control will continue fan operation and wait 15 minutes to attempt a restart. Fault will clear when restart is successful, or low voltage power is cycled.
	Contactors Shorted	73	Compressor voltage sensed when no demand for compressor operation exists. Contactor may be stuck closed or there is a wiring error.
	No 230V at Compressor	74	Compressor voltage not sensed when compressor should be starting. Disconnect may be open or contactor may be stuck open or there is a wiring error.
	Thermal Lockout	82	Thermal cutout occurs in three consecutive cycles. Unit operation locked out for 4 hours or until 24v power recycled.
	Low Pressure Lockout	83	Low pressure switch trip has occurred during 3 consecutive cycles. Unit operation locked out for 4 hours or until 24v power recycled.
	High Pressure Lockout	84	High pressure switch trip has occurred during 3 consecutive cycles. Unit operation locked out for 4 hours or until 24v power recycled.

Figure 8

Resistance vs Temperature Chart

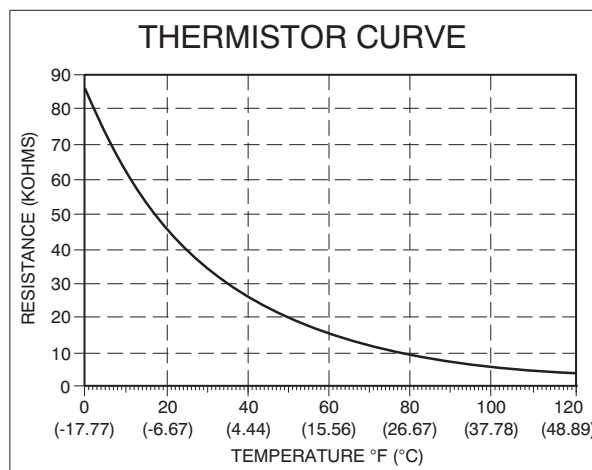

Figure 9

Single Stage Control Board

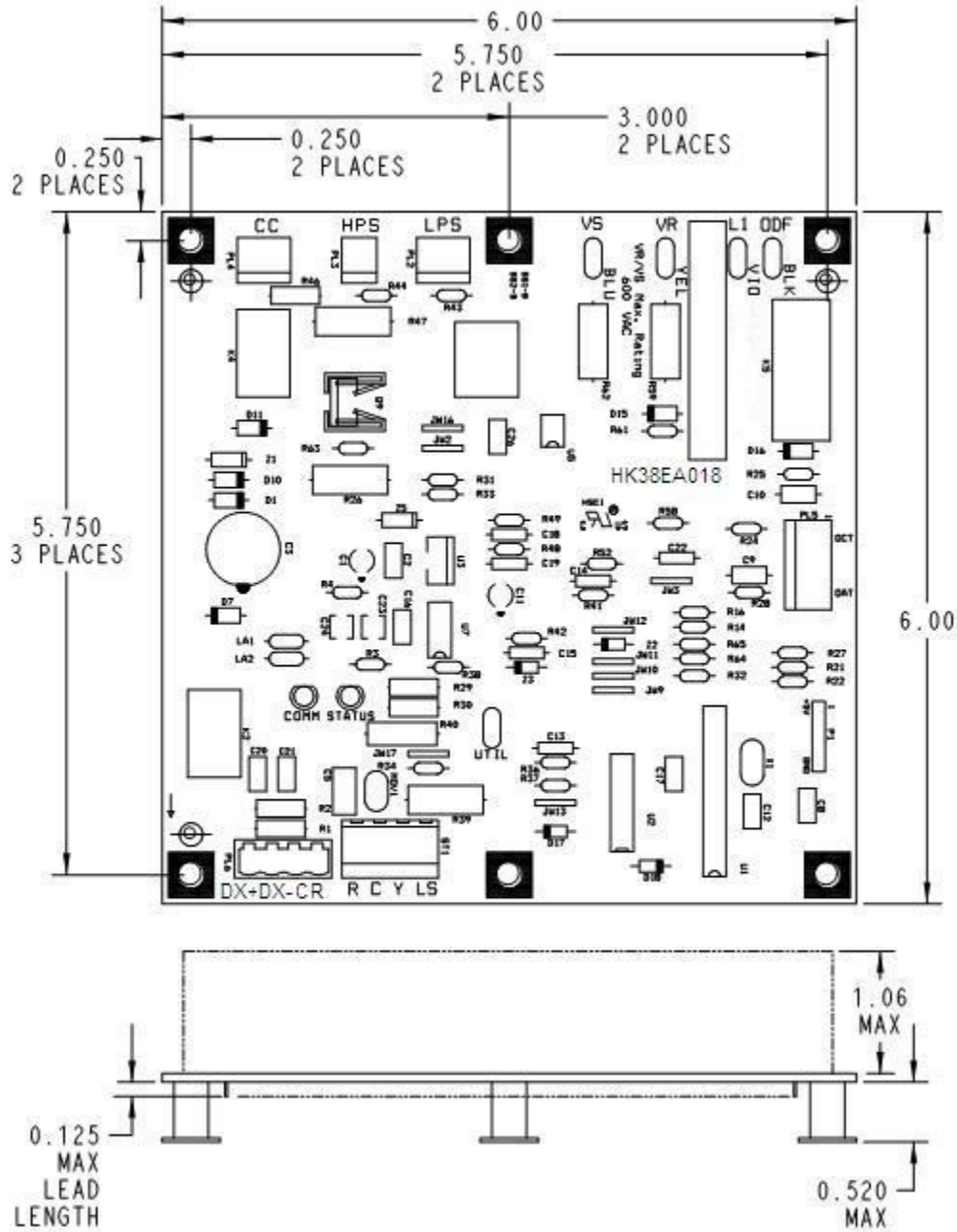

Figure 10

Observer Communicating Wall Control Four-Wire Connection Wiring Diagrams
(See Thermostat Installation Instructions for specific unit combinations)

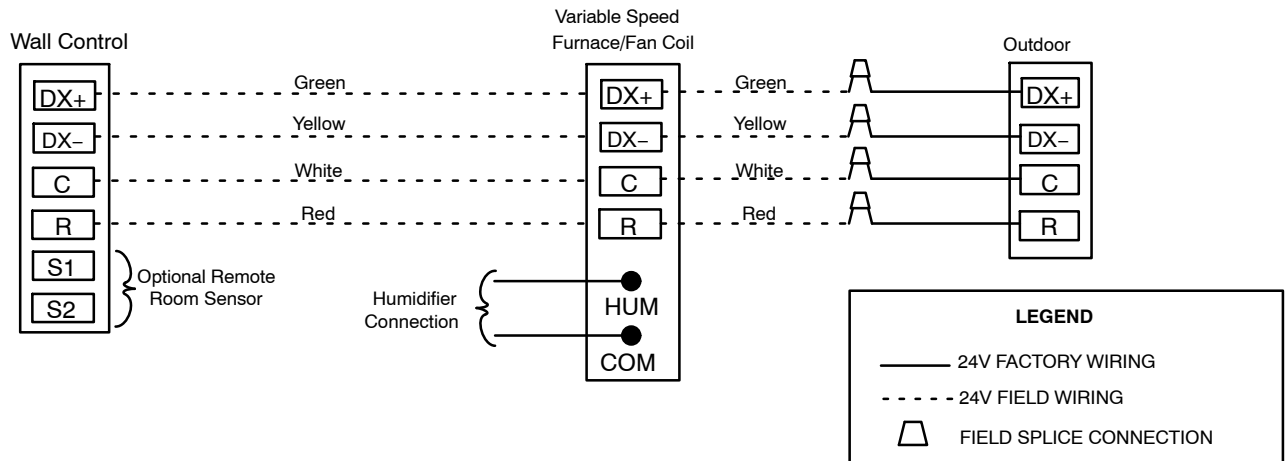
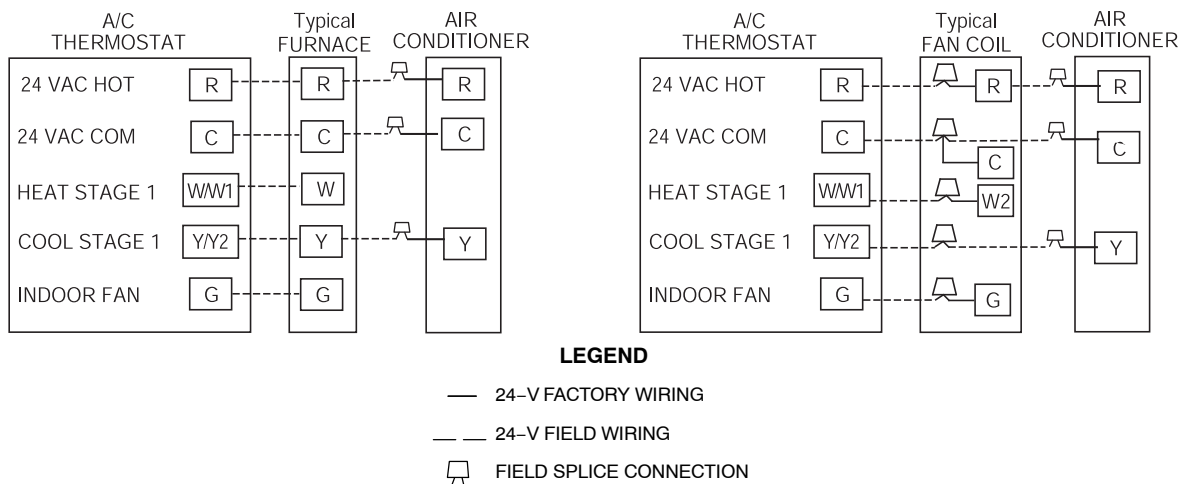

Figure 11

Non-Communicating Standard Thermostat 3-Wire 24V Circuit Connections
(See Thermostat Installation Instructions for Specific Unit combinations)



⚠ CAUTION

ELECTRICAL OPERATION HAZARD
Failure to follow this caution may result in equipment damage or improper operation.
A minimum of three wire thermostat wiring is required for the system to operate.

Figure 12

**Non-Communicating Standard Thermostat
2-Wire 24V Circuit Connections**

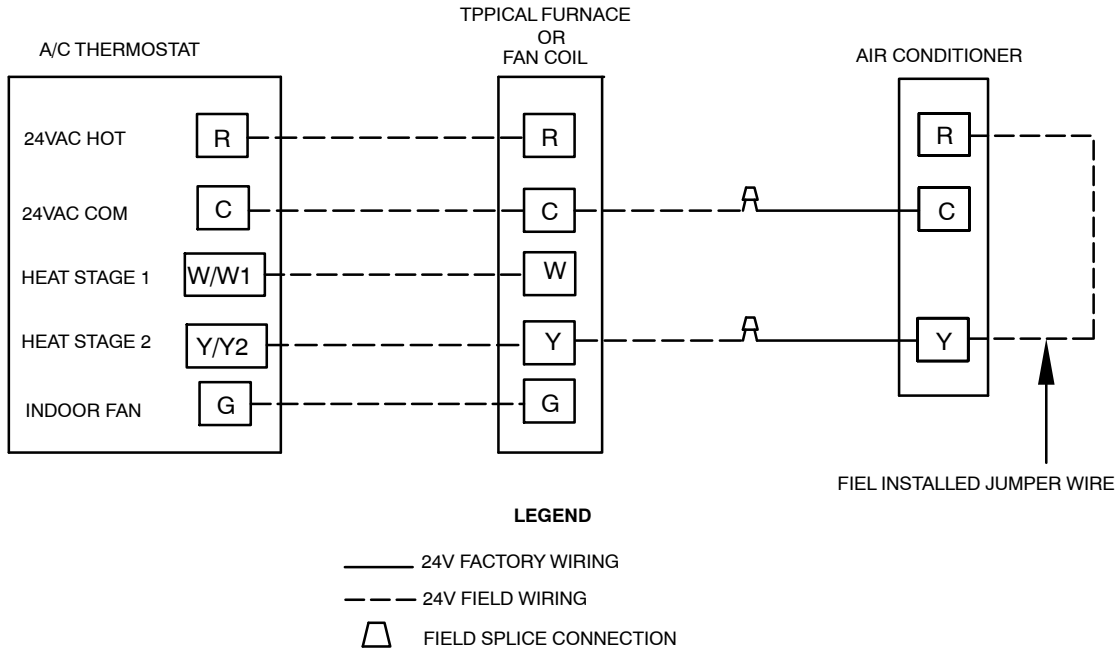

NOTE: Wiring must conform to NEC or local codes.

Figure 13

Non-Communicating Indoor with Observer Communicating Wall Control

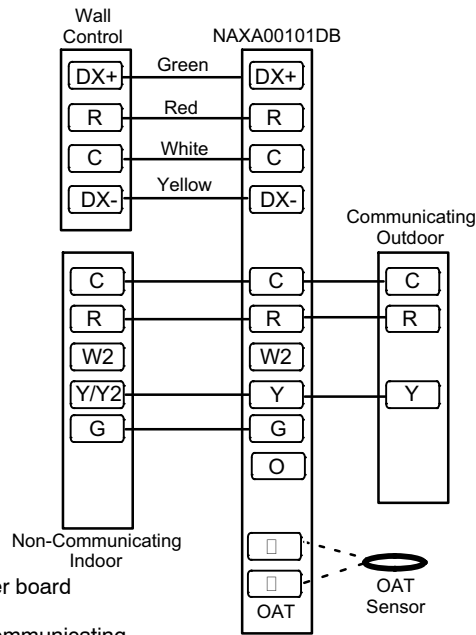

NOTE: This installation requires the daughter board accessory, NAXA00101DB.
NOTE: This installation does not allow for communicating feature functionality.

R-410A QUICK REFERENCE GUIDE

- R-410A refrigerant operates at 50% – 70% higher pressures than R-22. Be sure that servicing equipment and replacement components are designed to operate with R-410A.
- R-410A refrigerant cylinders are rose colored.
- Recovery cylinder service pressure rating must be 400 psig, DOT 4BA400 or DOT BW400.
- R-410A systems should be charged with liquid refrigerant. Use a commercial type metering device in the manifold hose.
- Manifold sets should be 750 psig high-side and 200 psig low-side with 520 psig low-side retard.
- Use hoses with 750 psig service pressure rating.
- Leak detectors should be designed to detect HFC refrigerant.
- R-410A, as with other HFC refrigerants, is only compatible with POE oils.
- Vacuum pumps will not remove moisture from oil.
- Do not use liquid line filter-driers with rated working pressures less than 600 psig.
- Do not install a suction line filter-drier in liquid line.
- POE oils absorb moisture rapidly. Do not expose oil to atmosphere.
- POE oils may cause damage to certain plastics and roofing materials.
- Wrap all filter-driers and service valves with wet cloth when brazing.
- A liquid line filter-drier is required on every unit.
- Do not use with an R-22 TXV.
- If indoor unit is equipped with an R-22 TXV, it must be changed to an R-410A TXV.
- Never open system to atmosphere while it is under a vacuum.
- When system must be opened for service, break vacuum with dry nitrogen and replace all filter-driers.
- Do not vent R-410A into the atmosphere.
- Do not use capillary tube indoor coils.
- Observe all **WARNINGS, CAUTIONS, NOTES**, and **bold** text.