



# PHX3

## Product Specifications

### 13 SEER R-410A PACKAGE HEAT PUMP UNIT (3 Phase) 3 - 5 TONS

#### REFRIGERATION CIRCUIT

- All models are equipped with high efficiency 2 stage Copeland scroll compressor.
- Thermostatic Expansion Valve (TXV) controls refrigerant flow for cooling, piston controls heating.
- High Efficiency X-13 indoor motors.
- High and Low pressure switches for excellent compressor protection.



#### BUILT TO LAST

- Galvanized-painted cabinet. One piece weather resistant top. Access panels for easy service. Side by side supply and return. Heavy gauge base rails.
- Triple-coated steel, consisting of a polyester top coat, a urethane primer coat preceded by an oxide pretreatment.
- Integral base rails with fork-lift access on three sides. Holes provided for lifting lugs makes rooftop installation easier.
- The condenser coil has a sturdy wire inlet grille and UV rated vinyl mesh installed on the surface of the coil for additional protection.
- Advanced Air Management System for quieter operation.

#### EASY TO INSTALL AND SERVICE

- Combination electric cooling/heating with field installed electric heat, self contained for year-round comfort. Systems installed on rooftop or ground level. The unit is shipped in the horizontal position and can easily be converted to downflow.
- Externally-mounted gauge ports allow for more accurate reading of operating conditions while servicing.
- Electrical controls located behind one exterior panel for easier maintenance.
- Pre-wired for economizer.

#### ELECTRIC HEAT

- Slip in electrical heat from 10 to 20 kW.

#### WARRANTY

- 5 year limited compressor warranty
- 1 year limited parts warranty



As an Energy Star® Partner, International Comfort Products has determined that this product meets the ENERGY STAR® guidelines for energy efficiency.

#### UNIT PERFORMANCE DATA

Model Number	COOLING		HEATING		Voltage/Phase/Hz	Unit Dimensions H x W x L	Ship Weight
	Rated Capacity BTUH	S.E.E.R	Nominal Capacity BTUH	HSPF			
PHX336000H00A	34,600	13.5	34,000	7.7	208/230-3-60	32-1/2 X 47-5/16 X 47-5/16	449
PHX336000L00A	34,600	13.5	34,000	7.7	460-3-60	32-1/2 X 47-5/16 X 47-5/16	449
PHX342000H00A	40,000	13.0	39,000	7.7	208/230-3-60	36 X 47-5/16 X 73	570
PHX342000L00A	40,000	13.0	39,000	7.7	460-3-60	36 X 47-5/16 X 73	570
PHX348000H00A	45,000	13.5	45,000	7.7	208/230-3-60	36 X 47-5/16 X 73	640
PHX348000L00A	45,000	13.5	45,000	7.7	460-3-60	36 X 47-5/16 X 73	640
PHX360000H00A	57,000	13.5	55,000	7.7	208/230-3-60	36 X 47-5/16 X 73	646
PHX360000L00A	57,000	13.5	55,000	7.7	460-3-60	36 X 47-5/16 X 73	646

516 51 1802 02

6/26/08

## UNIT SPECIFICATIONS

MODEL NUMBER	Electrical Data			Condenser Data									Sound Ratings (db)
	Voltage 3 Phase 60 Hz.	HACR	MCA	Coil			Fan Motor		Fan				
				Total Face Area (Sq. Ft.)	Fins Per In. / Rows	Tube Dia. (In.)	H.P.	Full Load Amps	Size Diameter (In.)	RPM Max.	CFM (Max.)		
PHX336000H00A	208/230	30 amps.	22.0	11.40	18 / 2	3/8	1/4	1.4	20	1100	2200	75	
PHX336000L00A	460	15 amps.	12.4	11.40	18 / 2	3/8	1/4	0.8	20	1100	2200	75	
PHX342000H00A	208/230	35 amps.	24.2	12.99	18 / 2	3/8	1/4	1.4	22	1100	2200	77	
PHX342000L00A	460	20 amps.	14.4	12.99	18 / 2	3/8	1/4	0.8	22	1100	2200	77	
PHX348000H00A	208/230	40 amps.	27.0	12.99	18 / 2	3/8	1/4	1.4	22	1100	2400	77	
PHX348000L00A	460	20 amps.	16.5	12.99	18 / 2	3/8	1/4	0.8	22	1100	2400	77	
PHX360000H00A	208/230	45 amps.	31.1	17.12	18 / 2	3/8	1/4	1.4	22	1100	3000	78	
PHX360000L00A	460	25 amps.	20.5	17.12	18 / 2	3/8	1/4	1.5	22	1100	3000	78	

MODEL NUMBER	Evaporator Coil											R410A Factory Refrigerant Charge (lbs)	Shipping Weight (Lbs)
	Coil			Motor			Blower			Compressor			
	Total Face Area (Sq. Ft.)	Fins Per In. / Rows	Tube Diameter (In.)	H.P.	Full Load Amps	No. of Speed Taps	Size	RPM (Max.)	CFM Rated	Rated Load Amps	Locked Rotor Amps		
PHX336000H00A	3.56	14 / 4	3/8	3/4	6.0	4	11 x 9	1050	1200	11.7	58.0	10.0	449
PHX336000L00A	3.56	14 / 4	3/8	3/4	6.0	4	11 x 9	1050	1200	4.5	29.0	10.0	449
PHX342000H00A	5.14	14 / 3	3/8	3/4	6.0	5	11 x 9	1050	1400	13.5	88.0	11.5	570
PHX342000L00A	5.14	14 / 3	3/8	3/4	6.0	5	11 x 9	1050	1400	6.1	44.0	11.5	570
PHX348000H00A	5.14	14 / 3	3/8	1.0	7.7	5	11 x 10	1050	1600	14.3	88.0	12.3	640
PHX348000L00A	5.14	14 / 3	3/8	1.0	7.7	5	11 x 10	1050	1600	6.4	88.0	12.3	640
PHX360000H00A	8.22	14 / 3	3/8	1.0	7.7	5	11 x 10	1050	2000	17.6	123.0	15.0	646
PHX360000L00A	8.22	14 / 3	3/8	1.0	7.7	5	11 x 10	1050	2000	9.0	62.0	15.0	646

## PERFORMANCE DATA: COOLING & HEATING

MODEL NUMBER	Cooling Data			Heating Data						Evaporator Rated Airflow (SCFM)
	Rated Capacity <sup>1</sup> BTUH Cooling	S.E.E.R.	E.E.R.	Rated Capacity BTUH @ 47°F	Rated Capacity BTUH @ 17°F	HSPF	S / T Ratio	COP		
								@ 47°F	17°F	
PHX336000H00A	34,600	13.5	10.0	34,000	18,600	7.7	.76	3.3	2.2	1200
PHX336000L00A	34,600	13.5	10.0	34,000	18,600	7.7	.76	3.3	2.2	1200
PHX342000H00A	40,000	13.0	10.0	39,000	21,600	7.7	.78	3.1	2.2	1400
PHX342000L00A	40,000	13.0	10.0	39,000	21,600	7.7	.78	3.1	2.2	1400
PHX348000H00A	45,000	13.5	10.2	45,000	24,400	7.7	.78	3.3	2.2	1600
PHX348000L00A	45,000	13.5	10.2	45,000	24,400	7.7	.78	3.3	2.2	1600
PHX360000H00A	57,000	13.5	10.0	55,000	30,200	7.7	.79	3.1	2.2	2000
PHX360000L00A	57,000	13.5	10.0	55,000	30,200	7.7	.79	3.1	2.2	2000

<sup>1</sup> Rated Capacity @ ARI standard conditions, 95° Amb, 80° DB/67° WB, 230 Volts. For applications at 208 volts deduct 1000 BTUH.

## BLOWER PERFORMANCE DATA

Model Number	PHX336					PHX342					PHX348					PHX360																										
	18.59		24.00		34.35		52.94		-		19.06		23.06		34.12		41.88		44.00		26.98		32.00		51.14		59.92		80.00		30.12		31.06		55.84		73.10		80.00			
	1	2	3	4	5	1	2	3	4	5	1	2	3	4	5	1	2	3	4	5	1	2	3	4	5	1	2	3	4	5	1	2	3	4	5							
Air Delivery in CFM @ Varying External Static Pressure (in. w.c.)	0.1	876	1026	1276	1630	-	973	1028	1302	1481	1569	1173	1304	1680	1831	2103	1300	1368	1839	2091	2188	0.2	841	994	1242	1588	-	900	969	1260	1448	1537	1127	1256	1650	1797	2051	1263	1321	1807	2056	2140
	0.3	794	949	1209	1526	-	853	924	1219	1412	1500	1085	1216	1614	1763	2001	1214	1283	1772	2023	2096	0.4	756	913	1179	1477	-	797	881	1179	1374	1463	1027	1167	1578	1732	1942	1169	1231	1735	1987	2039
	0.5	694	871	1150	1415	-	749	838	1138	1336	1423	983	1126	1544	1696	1878	1117	1197	1702	1935	1974	0.6	651	841	1117	1354	-	702	789	1103	1298	1389	927	1077	1507	1661	1809	1073	1144	1667	1878	1905
	0.7	598	793	1086	1287	-	642	731	1060	1263	1353	881	1026	1470	1621	1723	1026	1105	1629	1811	1827	0.8	543	735	1045	1216	-	581	680	1015	1226	1317	821	979	1427	1559	1632	975	1038	1590	1729	1745
	0.9	499	683	998	1145	-	529	617	963	1186	1276	764	921	1373	1446	1526	926	969	1535	1640	1642	1	464	638	946	1070	-	476	562	923	1143	1208	710	875	1289	1339	1388	862	913	1460	1536	1537

Notes: Air Delivery @ listed external static pressure are taken at 230Volts with Dry coil, no filter and approved heater. For wet coil add .05 in. wc. to Static Pressure measurement. Note for 208 Volts applications, reduce airflow by 15%.

MODEL	Blower Speed Tap Settings		
	Low Capacity Airflow	Rated Airflow	High Capacity Airflow
PHX336	Speed Tap 1	Speed Tap 3	Speed Tap 5
PHX342	Speed Tap 1	Speed Tap 4	Speed Tap 5
PHX348	Speed Tap 1	Speed Tap 3	Speed Tap 5
PHX360	Speed Tap 1	Speed Tap 3	Speed Tap 5

SPECIFICATIONS SUBJECT TO CHANGE WITHOUT NOTICE

**PHX3 ELECTRIC HEATER USAGE CHART**

	240v - 3ph - 60hz					480v - 3ph - 60hz			
	EHBA Heater Model No's (Example: EHBA10HN)					EHBA Heater Model No's (Example: EHBA10LN)			
Without Circuit Breakers	10HN		15HN			10LN	15LN	20LN	21LN
With Circuit Breakers		10HB		15HB	20HB				
Unit kW	10kW		15kW		20kW	10kW	15kW	20kW	
PHX3	USED ON					USED ON			
36	X	X		X	X	X	X	X	
42	X	X		X	X	X	X	X	
48	X	X		X	X	X	X		X
60		X		X	X	X	X		X

**PHX3 - ELECTRICAL DATA: ELECTRIC HEAT ACCESSORY**

Heater Model EHBA	Used With	Supply Voltage	KW Rating	Nom. Heating BTUH	Supply Circuit No.	Heater Amps	Min. Circuit Ampacity	Max Overcurrent Protective Device
10HN	3-4 Ton	240-3	10.0	34130	L4-L5-L6	24.1	30.1	30
		208-3	7.5	25598	L4-L5-L6	20.8	26.0	30
10HB	3-5 Ton	240-3	10.0	34130	L4-L5-L6	24.1	30.1	30
		208-3	7.5	25598	L4-L5-L6	20.8	26.0	30
15HB	3-5 Ton	240-3	15.0	51195	L4-L5-L6	36.1	45.1	45
		208-3	11.3	38567	L4-L5-L6	31.4	39.3	40
20HB	3-5 Ton	240-3	19.8	67577	L4-L5-L6	47.9	59.9	60
		208-3	14.9	50854	L4-L5-L6	41.4	51.8	60
10LN	3-5 Ton	480-3	10.0	34130	L4-L5-L6	12.0	15.0	15
15LN	3-5 Ton	480-3	15.0	51195	L4-L5-L6	18.0	22.5	25
20LN	3-3 1/2 Ton	480-3	20.0	68260	L4-L5-L6	24.1	30.1	30
21LN	4-5 Ton	480-3	20.0	68260	L4-L5-L6	24.1	30.1	30

**PHX3 - PERFORMANCE DATA: ELECTRIC HEAT ACCESSORY**

Heater Model EHBA	Used With	Supply Voltage	KW Rating	Nom. Heating BTUH	Temperature Rise F @ CFM					
					1200	1400	1600	1800	2000	2200
10HN	3-4 Ton	240-3	10.0	34130	26.4	22.6	19.8	17.6	15.8	14.4
		208-3	7.5	25598	19.8	17.0	14.8	13.1	11.9	10.7
10HB	3-5 Ton	240-3	10.0	34130	26.4	22.6	19.8	17.6	15.8	14.4
		208-3	7.5	25598	19.8	17.0	14.8	13.1	11.9	10.7
15HB	3-5 Ton	240-3	15.0	51195	39.5	33.9	29.6	26.4	23.7	21.2
		208-3	11.3	38567	27.3	25.4	22.2	19.8	17.8	16.1
20HB	3-5 Ton	240-3	19.8	67577	52.2	44.6	39.1	34.7	31.3	28.4
		208-3	14.9	50854	39.2	33.7	29.4	26.2	23.5	21.1
10LN	3-5 Ton	480-3	10.0	34130	26.4	22.6	19.8	17.6	15.8	14.4
15LN	3-5 Ton	480-3	15.0	51195	39.5	33.9	29.6	26.4	23.7	21.2
20LN	3-3 1/2 Ton	480-3	20.0	68260	52.7	45.1	39.5	35.1	31.6	28.7
21LN	4-5 Ton	480-3	20.0	68260	52.7	45.1	39.5	35.1	31.6	28.7

**EXPANDED PERFORMANCE DATA: COOLING**

**PHX336 (High Stage)**

OD Ambient (°F)	ID Airflow (SCFM)	1030					1200					1350				
		Entering Indoor Temperature - Degrees F, Wet Bulb														
		57	62	63 <sup>++</sup>	67	72	57	62	63 <sup>++</sup>	67	72	57	62	63 <sup>++</sup>	67	72
75	MBh <sup>+</sup>	35.8	37.2	37.9	41.0	45.1	37.6	38.3	38.9	42.0	46.2	39.1	39.3	39.7	42.9	47.1
	S/T	0.98	0.91	0.72	0.69	0.51	0.98	0.95	0.75	0.73	0.52	0.98	0.99	0.79	0.76	0.54
	kW*	2.40	2.41	2.42	2.44	2.47	2.56	2.57	2.58	2.60	2.63	2.73	2.73	2.73	2.76	2.79
85	MBh <sup>+</sup>	34.4	35.4	36.0	39.0	43.0	36.1	36.5	36.9	39.9	44.0	37.5	37.6	37.7	40.7	44.8
	S/T	0.98	0.93	0.74	0.71	0.51	0.98	0.98	0.77	0.74	0.53	0.98	0.98	0.81	0.78	0.55
	kW*	2.69	2.70	2.70	2.73	2.76	2.85	2.85	2.86	2.89	2.92	3.01	3.01	3.01	3.04	3.08
95	MBh <sup>+</sup>	33.0	33.6	34.1	36.9	40.7	34.5	34.6	34.9	37.8	41.7	35.9	35.9	35.6	38.5	42.4
	S/T	0.98	0.96	0.75	0.73	0.52	0.98	0.98	0.79	0.76	0.54	0.98	0.98	0.83	0.80	0.56
	kW*	2.99	3.00	3.01	3.04	3.07	3.16	3.16	3.17	3.19	3.23	3.32	3.32	3.32	3.35	3.39
105	MBh <sup>+</sup>	31.4	31.7	32.1	34.8	38.4	32.9	32.9	32.9	35.6	39.3	34.1	34.2	33.5	36.3	39.9
	S/T	0.98	0.98	0.77	0.74	0.53	0.98	0.98	0.81	0.79	0.55	0.98	0.98	0.85	0.83	0.57
	kW*	3.33	3.33	3.34	3.37	3.41	3.50	3.50	3.50	3.53	3.57	3.66	3.66	3.65	3.68	3.72
115	MBh <sup>+</sup>	29.8	29.8	30.0	32.6	36.0	31.1	31.2	30.7	33.3	36.8	32.3	32.3	31.2	33.9	37.3
	S/T	0.98	0.98	0.80	0.77	0.54	0.98	0.98	0.84	0.81	0.57	0.98	0.98	0.88	0.86	0.59
	kW*	3.69	3.69	3.70	3.73	3.77	3.86	3.86	3.85	3.89	3.93	4.02	4.02	4.01	4.04	4.08
125	MBh <sup>+</sup>	28.0	28.1	27.8	30.2	33.5	29.3	29.3	28.4	30.9	34.1	30.3	30.4	28.9	31.4	34.6
	S/T	0.98	0.98	0.83	0.80	0.56	0.98	0.98	0.87	0.85	0.58	0.98	0.98	0.92	0.89	0.61
	kW*	4.08	4.08	4.08	4.11	4.15	4.25	4.25	4.23	4.27	4.31	4.41	4.41	4.39	4.43	4.47

**PHX336 (Low Stage)**

OD Ambient (°F)	ID Airflow (SCFM)	750					850					950				
		Entering Indoor Temperature - Degrees F, Wet Bulb														
		57	62	63 <sup>++</sup>	67	72	57	62	63 <sup>++</sup>	67	72	57	62	63 <sup>++</sup>	67	72
75	MBh <sup>+</sup>	25.2	26.0	26.5	28.8	31.9	26.4	26.8	27.2	29.5	32.7	27.5	27.6	27.8	30.2	33.3
	S/T	0.98	0.92	0.73	0.71	0.51	0.98	0.97	0.77	0.74	0.53	0.98	0.98	0.80	0.77	0.55
	kW*	1.23	1.19	1.17	1.07	0.94	1.20	1.18	1.17	1.07	0.93	1.18	1.17	1.17	1.06	0.92
85	MBh <sup>+</sup>	24.1	24.6	25.0	27.2	30.2	25.2	25.3	25.6	27.9	30.9	26.2	26.3	26.2	28.4	31.5
	S/T	0.98	0.95	0.75	0.72	0.52	0.98	0.99	0.79	0.76	0.54	0.98	0.98	0.82	0.79	0.56
	kW*	1.48	1.46	1.44	1.34	1.22	1.45	1.45	1.44	1.34	1.21	1.44	1.43	1.44	1.34	1.21
95	MBh <sup>+</sup>	22.9	23.1	23.5	25.6	28.4	24.0	24.0	24.1	26.2	29.1	24.9	25.0	24.5	26.7	29.6
	S/T	0.98	0.98	0.77	0.74	0.53	0.98	0.98	0.81	0.78	0.55	0.98	0.98	0.84	0.82	0.57
	kW*	1.75	1.74	1.73	1.64	1.51	1.73	1.73	1.73	1.64	1.51	1.72	1.72	1.73	1.64	1.51
105	MBh <sup>+</sup>	21.7	21.8	22.0	24.0	26.6	22.7	22.8	22.5	24.5	27.2	23.6	23.6	22.9	24.9	27.7
	S/T	0.98	0.98	0.80	0.77	0.54	0.98	0.98	0.84	0.81	0.56	0.98	0.98	0.87	0.85	0.59
	kW*	2.05	2.05	2.04	1.96	1.84	2.03	2.03	2.05	1.96	1.84	2.02	2.02	2.05	1.96	1.84
115	MBh <sup>+</sup>	20.5	20.5	20.4	22.3	24.8	21.4	21.4	20.8	22.7	25.3	22.2	22.2	21.2	23.1	25.7
	S/T	0.98	0.98	0.82	0.79	0.56	0.98	0.98	0.87	0.84	0.58	0.98	0.98	0.91	0.88	0.61
	kW*	2.38	2.37	2.38	2.30	2.19	2.36	2.36	2.39	2.30	2.19	2.35	2.35	2.40	2.31	2.19
125	MBh <sup>+</sup>	19.2	19.2	18.7	20.5	22.8	20.0	20.0	19.1	20.9	23.3	20.7	20.8	19.5	21.3	23.6
	S/T	0.98	0.98	0.86	0.83	0.57	0.98	0.98	0.91	0.88	0.60	0.98	0.98	0.95	0.92	0.63
	kW*	2.73	2.72	2.74	2.67	2.56	2.71	2.71	2.75	2.68	2.57	2.71	2.71	2.76	2.68	2.57

Notes: When the required data fall between the published data, interpolation may be performed. Extrapolation is not an acceptable practice.

+Total capacities are net capacities. Blower heat has been subtracted.

++ At TVA rating indoor condition (75 F db/ 63 F wb), All other indoor air temperatures are at 80 F db

\* System kW is total unit kW

Standard Rating =

S/T are based on 80°F db entering air at the indoor coil. For sensible capacities at other than 80°5 db, deduct 83° Btuh per 1000 cfm of indoor coil air from (MBh x S/T) for each degree below 80°F, or add 835 Btuh per 1000 cfm of indoor coil air from (MBh x S/T) for each degree above 80°F.

**EXPANDED PERFORMANCE DATA: COOLING**

**PHX342 (High Stage)**

OD Ambient (°F)	ID Airflow (SCFM)	1225					1400					1575				
		Entering Indoor Temperature - Degrees F, Wet Bulb														
		57	62	63 <sup>++</sup>	67	72	57	62	63 <sup>++</sup>	67	72	57	62	63 <sup>++</sup>	67	72
75	MBh <sup>+</sup>	41.3	42.5	43.2	46.5	50.7	43.2	43.7	44.3	47.6	51.8	44.9	44.9	45.2	48.4	52.7
	S/T	0.98	0.92	0.73	0.70	0.51	0.98	0.97	0.76	0.74	0.53	0.98	0.98	0.80	0.78	0.55
	kW*	2.80	2.81	2.82	2.85	2.89	2.92	2.92	2.93	2.96	3.01	2.99	2.99	3.00	3.03	3.08
85	MBh <sup>+</sup>	39.7	40.6	41.3	44.4	48.4	41.6	41.7	42.2	45.4	49.4	43.1	43.2	43.0	46.1	50.1
	S/T	0.98	0.94	0.74	0.72	0.52	0.98	0.99	0.78	0.76	0.54	0.98	0.98	0.82	0.79	0.56
	kW*	3.08	3.09	3.10	3.13	3.17	3.20	3.20	3.21	3.24	3.29	3.28	3.28	3.27	3.31	3.35
95	MBh <sup>+</sup>	38.1	38.6	39.2	42.1	45.9	39.8	39.9	40.0	43.0	46.8	41.2	41.3	40.7	43.7	47.4
	S/T	0.98	0.97	0.76	0.73	0.53	0.98	0.98	0.80	0.78	0.55	0.98	0.98	0.84	0.82	0.57
	kW*	3.39	3.40	3.40	3.44	3.48	3.51	3.51	3.51	3.55	3.59	3.58	3.59	3.58	3.61	3.66
105	MBh <sup>+</sup>	36.4	36.5	37.0	39.7	43.3	37.9	38.0	37.7	40.5	44.0	39.2	39.3	38.4	41.1	44.6
	S/T	0.98	0.99	0.78	0.75	0.54	0.98	0.98	0.82	0.80	0.56	0.98	0.98	0.87	0.84	0.59
	kW*	3.73	3.73	3.74	3.77	3.82	3.85	3.85	3.85	3.88	3.93	3.92	3.93	3.91	3.95	4.00
115	MBh <sup>+</sup>	34.4	34.5	34.6	37.1	40.4	35.8	35.9	35.3	37.8	41.1	37.0	37.1	35.8	38.4	41.6
	S/T	0.98	0.98	0.80	0.78	0.55	0.98	0.98	0.85	0.83	0.58	0.98	0.98	0.90	0.88	0.61
	kW*	4.10	4.10	4.10	4.14	4.18	4.22	4.22	4.21	4.25	4.29	4.29	4.29	4.28	4.31	4.36
125	MBh <sup>+</sup>	32.3	32.3	31.9	34.3	37.2	33.5	33.6	32.5	34.9	37.7	34.5	34.6	33.0	35.3	38.2
	S/T	0.98	0.98	0.84	0.81	0.57	0.98	0.98	0.89	0.87	0.60	0.98	0.98	0.94	0.92	0.63
	kW*	4.50	4.50	4.49	4.53	4.57	4.61	4.62	4.60	4.64	4.68	4.69	4.69	4.67	4.70	4.74

**PHX342 (Low Stage)**

OD Ambient (°F)	ID Airflow (SCFM)	800					900					1000				
		Entering Indoor Temperature - Degrees F, Wet Bulb														
		57	62	63 <sup>++</sup>	67	72	57	62	63 <sup>++</sup>	67	72	57	62	63 <sup>++</sup>	67	72
75	MBh <sup>+</sup>	30.7	31.4	32.0	34.7	38.4	32.1	32.3	32.8	35.6	39.3	33.3	33.4	33.4	36.3	40.0
	S/T	0.98	0.94	0.75	0.72	0.52	0.98	0.99	0.78	0.75	0.54	0.98	0.98	0.81	0.78	0.55
	kW*	1.35	1.32	1.29	1.16	0.99	1.31	1.30	1.28	1.15	0.97	1.29	1.29	1.28	1.15	0.97
85	MBh <sup>+</sup>	29.3	29.6	30.2	32.8	36.3	30.6	30.6	30.9	33.5	37.1	31.7	31.8	31.5	34.1	37.7
	S/T	0.98	0.97	0.77	0.74	0.53	0.98	0.98	0.80	0.77	0.55	0.98	0.98	0.83	0.80	0.57
	kW*	1.65	1.64	1.61	1.49	1.33	1.62	1.61	1.60	1.48	1.31	1.60	1.60	1.61	1.49	1.32
95	MBh <sup>+</sup>	27.8	27.9	28.3	30.8	34.1	29.0	29.1	28.9	31.5	34.8	30.1	30.2	29.5	32.0	35.4
	S/T	0.98	0.98	0.79	0.76	0.54	0.98	0.98	0.82	0.79	0.56	0.98	0.98	0.86	0.83	0.58
	kW*	1.98	1.98	1.96	1.85	1.69	1.95	1.95	1.96	1.84	1.68	1.94	1.93	1.97	1.85	1.69
105	MBh <sup>+</sup>	26.3	26.4	26.4	28.8	31.9	27.5	27.5	26.9	29.4	32.5	28.5	28.5	27.4	29.9	33.0
	S/T	0.98	0.98	0.81	0.78	0.55	0.98	0.98	0.85	0.82	0.58	0.98	0.98	0.89	0.86	0.60
	kW*	2.34	2.34	2.34	2.23	2.08	2.31	2.31	2.34	2.22	2.07	2.30	2.30	2.35	2.24	2.08
115	MBh <sup>+</sup>	24.8	24.8	24.4	26.7	29.6	25.8	25.9	24.9	27.2	30.2	26.7	26.8	25.4	27.6	30.6
	S/T	0.98	0.98	0.85	0.81	0.57	0.98	0.98	0.89	0.86	0.59	0.98	0.98	0.93	0.90	0.62
	kW*	2.73	2.72	2.74	2.64	2.50	2.70	2.70	2.75	2.64	2.50	2.70	2.70	2.76	2.66	2.51
125	MBh <sup>+</sup>	23.1	23.2	22.4	24.5	27.2	24.1	24.1	22.8	24.9	27.7	24.9	24.9	23.2	25.3	28.1
	S/T	0.98	0.98	0.88	0.85	0.59	0.98	0.98	0.93	0.90	0.62	0.98	0.98	0.98	0.95	0.64
	kW*	3.15	3.14	3.18	3.09	2.95	3.13	3.13	3.19	3.09	2.95	3.12	3.12	3.20	3.10	2.97

Notes: When the required data fall between the published data, interpolation may be performed. Extrapolation is not an acceptable practice.

+Total capacities are net capacities. Blower heat has been subtracted.

++ At TVA rating indoor condition (75 F db/ 63 F wb), All other indoor air temperatures are at 80 F db

\* System kW is total unit kW

Standard Rating =

S/T are based on 80°F db entering air at the indoor coil. For sensible capacities at other than 80°5 db, deduct 83° Btuh per 1000 cfm of indoor coil air from (MBh x S/T) for each degree below 80°F, or add 835 Btuh per 1000 cfm of indoor coil air from (MBh x S/T) for each degree above 80°F.

**EXPANDED PERFORMANCE DATA: COOLING**

**PHX348 (High Stage)**

OD Ambient (°F)	ID Airflow (SCFM)	1400					1600					1800				
		Entering Indoor Temperature - Degrees F, Wet Bulb														
		57	62	63 <sup>++</sup>	67	72	57	62	63 <sup>++</sup>	67	72	57	62	63 <sup>++</sup>	67	72
75	MBh <sup>+</sup>	47.6	49.0	49.8	53.7	58.7	49.9	50.4	51.0	54.9	60.0	51.8	51.9	52.0	56.0	61.1
	S/T	0.98	0.93	0.73	0.71	0.51	0.98	0.98	0.77	0.74	0.53	0.98	0.98	0.80	0.78	0.55
	kW*	3.53	3.55	3.56	3.60	3.67	3.68	3.69	3.70	3.75	3.81	3.83	3.83	3.83	3.88	3.94
85	MBh <sup>+</sup>	45.8	46.8	47.5	51.3	56.1	48.0	48.2	48.7	52.4	57.3	49.8	49.9	49.6	53.4	58.2
	S/T	0.98	0.95	0.75	0.72	0.52	0.98	0.98	0.78	0.76	0.54	0.98	0.98	0.82	0.80	0.56
	kW*	3.86	3.87	3.88	3.93	4.00	4.02	4.02	4.03	4.08	4.14	4.16	4.16	4.16	4.21	4.28
95	MBh <sup>+</sup>	44.0	44.5	45.2	48.8	53.4	46.0	46.1	46.2	49.8	54.5	47.7	47.8	47.1	50.7	55.3
	S/T	0.98	0.97	0.76	0.74	0.53	0.98	0.98	0.80	0.78	0.55	0.98	0.98	0.84	0.82	0.57
	kW*	4.22	4.23	4.24	4.30	4.36	4.38	4.38	4.39	4.44	4.51	4.53	4.53	4.52	4.57	4.64
105	MBh <sup>+</sup>	42.1	42.2	42.7	46.2	50.5	44.0	44.0	43.7	47.1	51.5	45.5	45.6	44.5	47.9	52.3
	S/T	0.98	0.98	0.78	0.76	0.54	0.98	0.98	0.83	0.80	0.56	0.98	0.98	0.87	0.84	0.58
	kW*	4.62	4.63	4.64	4.69	4.76	4.78	4.78	4.78	4.84	4.90	4.93	4.93	4.91	4.97	5.03
115	MBh <sup>+</sup>	40.0	40.1	40.2	43.4	47.5	41.7	41.8	41.0	44.2	48.3	43.2	43.2	41.7	44.9	49.0
	S/T	0.98	0.98	0.81	0.78	0.55	0.98	0.98	0.85	0.83	0.57	0.98	0.98	0.90	0.87	0.60
	kW*	5.06	5.06	5.06	5.12	5.19	5.22	5.22	5.21	5.26	5.33	5.36	5.36	5.34	5.39	5.46
125	MBh <sup>+</sup>	37.8	37.8	37.4	40.3	44.1	39.3	39.4	38.1	41.0	44.8	40.6	40.6	38.7	41.7	45.3
	S/T	0.98	0.98	0.83	0.81	0.56	0.98	0.98	0.88	0.86	0.59	0.98	0.98	0.93	0.91	0.62
	kW*	5.54	5.54	5.53	5.58	5.65	5.69	5.69	5.67	5.73	5.79	5.83	5.84	5.80	5.86	5.92

**PHX348 (Low Stage)**

OD Ambient (°F)	ID Airflow (SCFM)	950					1100					1250				
		Entering Indoor Temperature - Degrees F, Wet Bulb														
		57	62	63 <sup>++</sup>	67	72	57	62	63 <sup>++</sup>	67	72	57	62	63 <sup>++</sup>	67	72
75	MBh <sup>+</sup>	33.7	35.0	35.6	38.6	42.6	35.7	36.2	36.7	39.8	43.8	37.3	37.4	37.6	40.7	44.8
	S/T	0.98	0.92	0.73	0.70	0.51	0.98	0.97	0.76	0.73	0.53	0.98	0.98	0.80	0.77	0.55
	kW*	2.03	2.00	1.99	1.92	1.82	2.01	2.00	1.99	1.91	1.81	2.03	2.03	2.03	1.95	1.85
85	MBh <sup>+</sup>	32.4	33.2	33.9	36.8	40.6	34.2	34.4	34.9	37.8	41.7	35.8	35.8	35.7	38.7	42.6
	S/T	0.98	0.94	0.74	0.71	0.52	0.98	0.99	0.78	0.75	0.54	0.98	0.98	0.82	0.79	0.56
	kW*	2.33	2.31	2.29	2.22	2.13	2.31	2.31	2.29	2.22	2.13	2.33	2.33	2.33	2.26	2.16
95	MBh <sup>+</sup>	31.0	31.5	32.1	34.8	38.5	32.7	32.8	33.0	35.8	39.6	34.2	34.3	33.7	36.6	40.3
	S/T	0.98	0.97	0.76	0.73	0.53	0.98	0.98	0.80	0.77	0.55	0.98	0.98	0.84	0.81	0.57
	kW*	2.65	2.64	2.63	2.56	2.47	2.64	2.64	2.63	2.57	2.47	2.66	2.66	2.68	2.61	2.51
105	MBh <sup>+</sup>	29.6	29.7	30.2	32.9	36.4	31.2	31.3	31.1	33.8	37.3	32.6	32.6	31.7	34.5	38.0
	S/T	0.98	0.99	0.78	0.75	0.53	0.98	0.98	0.82	0.80	0.56	0.98	0.98	0.87	0.84	0.58
	kW*	3.01	3.01	3.00	2.94	2.85	3.00	3.00	3.00	2.94	2.85	3.03	3.03	3.05	2.99	2.89
115	MBh <sup>+</sup>	28.1	28.1	28.3	30.8	34.2	29.6	29.7	29.1	31.6	35.0	30.9	30.9	29.7	32.3	35.6
	S/T	0.98	0.98	0.80	0.77	0.55	0.98	0.98	0.85	0.82	0.57	0.98	0.98	0.90	0.87	0.60
	kW*	3.41	3.41	3.41	3.35	3.27	3.40	3.40	3.42	3.36	3.27	3.43	3.43	3.46	3.40	3.32
125	MBh <sup>+</sup>	26.5	26.6	26.3	28.7	31.8	27.9	27.9	27.0	29.4	32.5	29.0	29.1	27.5	30.0	33.1
	S/T	0.98	0.98	0.83	0.80	0.56	0.98	0.98	0.89	0.86	0.59	0.98	0.98	0.94	0.91	0.62
	kW*	3.85	3.85	3.86	3.81	3.73	3.85	3.85	3.87	3.82	3.73	3.88	3.88	3.92	3.86	3.78

Notes: When the required data fall between the published data, interpolation may be performed. Extrapolation is not an acceptable practice.

+Total capacities are net capacities. Blower heat has been subtracted.

++ At TVA rating indoor condition (75 F db/ 63 F wb), All other indoor air temperatures are at 80 F db

\* System kW is total unit kW

Standard Rating =

S/T are based on 80°F db entering air at the indoor coil. For sensible capacities at other than 80°5 db, deduct 83° Btuh per 1000 cfm of indoor coil air from (MBh x S/T) for each degree below 80°F, or add 835 Btuh per 1000 cfm of indoor coil air from (MBh x S/T) for each degree above 80°F.

**EXPANDED PERFORMANCE DATA: COOLING**

**PHX360 (High Stage)**

OD Ambient (°F)	ID Airflow (SCFM)	1750					2000					2250				
		Entering Indoor Temperature - Degrees F, Wet Bulb														
		57	62	63 <sup>++</sup>	67	72	57	62	63 <sup>++</sup>	67	72	57	62	63 <sup>++</sup>	67	72
75	MBh <sup>+</sup>	60.5	62.0	63.0	67.2	72.8	63.2	63.6	64.4	68.6	74.1	65.4	65.5	65.5	69.7	75.2
	S/T	0.98	0.93	0.73	0.71	0.51	0.98	0.99	0.77	0.75	0.53	0.98	0.98	0.81	0.79	0.56
	kW*	4.77	4.79	4.81	4.89	5.01	5.08	5.08	5.10	5.18	5.30	5.26	5.26	5.26	5.34	5.46
85	MBh <sup>+</sup>	58.2	59.1	60.0	64.0	69.2	60.6	60.7	61.2	65.3	70.5	62.7	62.8	62.3	66.3	71.4
	S/T	0.98	0.96	0.75	0.73	0.52	0.98	0.98	0.79	0.77	0.54	0.98	0.98	0.83	0.81	0.57
	kW*	5.22	5.23	5.25	5.34	5.45	5.53	5.53	5.54	5.62	5.73	5.71	5.71	5.70	5.78	5.90
95	MBh <sup>+</sup>	55.6	56.0	56.8	60.6	65.6	57.9	58.0	57.9	61.7	66.6	59.8	59.9	58.8	62.6	67.5
	S/T	0.98	0.98	0.77	0.74	0.53	0.98	0.98	0.81	0.79	0.55	0.98	0.98	0.85	0.83	0.58
	kW*	5.71	5.71	5.73	5.81	5.92	6.01	6.02	6.01	6.10	6.21	6.20	6.20	6.17	6.26	6.37
105	MBh <sup>+</sup>	52.9	52.9	53.4	57.0	61.6	55.0	55.0	54.4	58.0	62.5	56.7	56.7	55.3	58.8	63.3
	S/T	0.98	0.98	0.79	0.77	0.54	0.98	0.98	0.83	0.81	0.57	0.98	0.98	0.88	0.86	0.60
	kW*	6.23	6.23	6.24	6.33	6.43	6.54	6.54	6.53	6.61	6.72	6.72	6.72	6.69	6.77	6.88
115	MBh <sup>+</sup>	49.8	49.9	49.7	53.0	57.2	51.7	51.7	50.6	53.9	58.0	53.2	53.3	51.3	54.6	58.6
	S/T	0.98	0.98	0.81	0.79	0.55	0.98	0.98	0.87	0.85	0.59	0.98	0.98	0.92	0.90	0.62
	kW*	6.80	6.79	6.79	6.87	6.97	7.10	7.10	7.07	7.15	7.25	7.28	7.28	7.23	7.31	7.41
125	MBh <sup>+</sup>	46.3	46.4	45.6	48.5	52.3	47.9	48.0	46.3	49.3	52.9	49.2	49.3	47.0	49.9	53.5
	S/T	0.98	0.98	0.85	0.83	0.57	0.98	0.98	0.91	0.89	0.61	0.98	0.98	0.96	0.95	0.64
	kW*	7.39	7.39	7.37	7.44	7.54	7.69	7.69	7.65	7.72	7.81	7.86	7.86	7.80	7.88	7.97

**PHX360 (Low Stage)**

OD Ambient (°F)	ID Airflow (SCFM)	1125					1300					1475				
		Entering Indoor Temperature - Degrees F, Wet Bulb														
		57	62	63 <sup>++</sup>	67	72	57	62	63 <sup>++</sup>	67	72	57	62	63 <sup>++</sup>	67	72
75	MBh <sup>+</sup>	42.6	44.2	45.0	48.2	52.4	44.8	45.5	46.3	49.5	53.7	46.7	46.8	47.2	50.5	54.6
	S/T	0.98	0.91	0.72	0.70	0.51	0.98	0.96	0.76	0.73	0.53	0.98	0.98	0.79	0.77	0.55
	kW*	2.85	2.83	2.82	2.78	2.74	2.87	2.86	2.86	2.82	2.78	2.90	2.90	2.90	2.86	2.81
85	MBh <sup>+</sup>	41.0	42.2	43.0	46.0	50.0	43.1	43.4	44.1	47.2	51.1	44.9	44.9	45.0	48.0	52.0
	S/T	0.98	0.93	0.74	0.71	0.52	0.98	0.98	0.77	0.75	0.54	0.98	0.98	0.81	0.79	0.56
	kW*	3.24	3.23	3.22	3.18	3.14	3.26	3.26	3.25	3.22	3.17	3.30	3.30	3.30	3.26	3.21
95	MBh <sup>+</sup>	39.4	40.1	40.8	43.7	47.4	41.3	41.4	41.8	44.7	48.4	42.9	43.0	42.6	45.5	49.2
	S/T	0.98	0.95	0.75	0.73	0.53	0.98	0.98	0.79	0.77	0.55	0.98	0.98	0.83	0.81	0.57
	kW*	3.67	3.66	3.65	3.62	3.57	3.70	3.70	3.69	3.65	3.61	3.73	3.73	3.73	3.69	3.65
105	MBh <sup>+</sup>	37.6	37.9	38.5	41.2	44.7	39.3	39.4	39.4	42.1	45.6	40.8	40.9	40.1	42.8	46.3
	S/T	0.98	0.98	0.77	0.75	0.54	0.98	0.98	0.81	0.79	0.56	0.98	0.98	0.86	0.84	0.59
	kW*	4.14	4.14	4.13	4.09	4.04	4.17	4.17	4.17	4.13	4.08	4.20	4.20	4.21	4.17	4.12
115	MBh <sup>+</sup>	35.6	35.6	36.0	38.5	41.8	37.2	37.2	36.8	39.3	42.6	38.5	38.6	37.4	40.0	43.2
	S/T	0.98	0.98	0.79	0.77	0.55	0.98	0.98	0.84	0.82	0.58	0.98	0.98	0.89	0.87	0.61
	kW*	4.65	4.65	4.64	4.61	4.55	4.68	4.68	4.68	4.64	4.59	4.71	4.71	4.72	4.68	4.63
125	MBh <sup>+</sup>	33.3	33.4	33.3	35.6	38.6	34.8	34.8	33.9	36.3	39.2	35.9	36.0	34.5	36.8	39.7
	S/T	0.98	0.98	0.82	0.80	0.56	0.98	0.98	0.88	0.86	0.60	0.98	0.98	0.93	0.91	0.63
	kW*	5.20	5.19	5.20	5.16	5.10	5.22	5.22	5.24	5.19	5.13	5.25	5.25	5.28	5.23	5.17

Notes: When the required data fall between the published data, interpolation may be performed. Extrapolation is not an acceptable practice.

+Total capacities are net capacities. Blower heat has been subtracted.

++ At TVA rating indoor condition (75 F db/ 63 F wb), All other indoor air temperatures are at 80 F db

\* System kW is total unit kW

Standard Rating =

S/T are based on 80°F db entering air at the indoor coil. For sensible capacities at other than 80°5 db, deduct 83° Btuh per 1000 cfm of indoor coil air from (MBh x S/T) for each degree below 80°F, or add 835 Btuh per 1000 cfm of indoor coil air from (MBh x S/T) for each degree above 80°F.

# HEATING EXPANDED PERFORMANCE

Return Air (F db)		CFM (Standard Air)	PHX336 (High Capacity)																			
			Air Temperature Entering Outdoor Coil (F)																			
			-10		0		10		17		20		30		40		47		50		60	
60	1050	TC	9.8	9.0	14.4	13.3	21.8	20.0	26.0	23.7	25.5	23.2	28.8	25.2	31.9	31.9	34.1	34.1	36.1	36.1	43.9	43.9
		kW	2.71		2.74		2.77		2.80		2.84		2.77		2.70		2.67		2.69		2.80	
	1200	TC	8.8	8.1	13.9	12.8	19.1	17.5	26.0	23.7	27.6	25.0	31.2	27.3	34.3	34.3	36.6	36.6	38.6	38.6	46.5	46.5
		kW	2.86		2.88		2.89		2.92		2.90		2.83		2.76		2.71		2.72		2.79	
	1350	TC	3.4	3.2	9.6	8.9	15.8	14.5	22.0	20.1	26.0	23.6	32.4	28.4	36.4	36.4	38.7	38.7	40.6	40.6	48.6	48.6
		kW	2.93		2.94		2.94		2.95		2.94		2.88		2.80		2.74		2.74		2.78	
70	1050	TC	6.5	6.0	11.2	10.3	15.8	14.5	22.6	20.6	23.2	21.0	26.4	23.2	29.4	29.4	31.7	31.7	33.5	33.5	41.0	41.0
		kW	3.05		3.08		3.12		3.16		3.15		3.09		3.01		2.98		2.99		3.11	
	1200	TC	7.9	7.3	12.8	11.7	17.6	16.2	24.2	22.1	25.7	23.3	28.5	25.0	31.7	31.7	34.0	34.0	35.9	35.9	43.3	43.3
		kW	3.16		3.18		3.20		3.22		3.21		3.15		3.07		3.02		3.03		3.10	
	1350	TC	4.3	4.0	10.0	9.2	15.6	14.3	21.3	19.4	25.4	23.0	30.4	26.6	33.7	33.7	36.1	36.1	38.0	38.0	45.4	45.4
		kW	3.23		3.24		3.26		3.27		3.25		3.19		3.11		3.05		3.06		3.09	
80	1050	TC	5.2	4.8	9.7	8.9	14.1	12.9	20.8	18.9	21.3	19.3	24.0	21.0	27.1	27.1	29.4	29.4	31.2	31.2	38.4	38.4
		kW	3.34		3.38		3.42		3.49		3.48		3.43		3.36		3.31		3.33		3.46	
	1200	TC	7.0	6.5	11.6	10.7	16.1	14.8	22.4	20.5	23.8	21.6	26.5	23.2	29.2	29.2	31.6	31.6	33.4	33.4	40.6	40.6
		kW	3.42		3.45		3.45		3.55		3.54		3.49		3.42		3.36		3.37		3.45	
	1350	TC	3.9	3.6	9.2	8.5	14.5	13.3	20.8	19.0	22.4	20.3	28.4	24.8	31.5	31.5	33.6	33.6	35.5	35.5	42.6	42.6
		kW	3.50		3.52		3.55		3.56		3.57		3.53		3.46		3.40		3.40		3.44	

Return Air (F db)		CFM (Standard Air)	PHX336 (Low Capacity)																			
			Air Temperature Entering Outdoor Coil (F)																			
			-10		0		10		17		20		30		40		47		50		60	
60	750	TC	9.0	8.3	12.0	11.1	16.0	14.7	19.7	18.0	20.5	18.6	23.0	20.2	24.7	24.7	25.2	25.2	27.1	27.1	33.8	33.8
		kW	2.15		2.11		2.08		2.02		2.00		1.93		1.83		1.75		1.71		1.57	
	850	TC	11.9	11.0	15.9	14.7	17.7	16.3	21.5	19.6	22.4	20.3	24.6	21.6	26.1	26.1	26.5	26.5	28.3	28.3	35.3	35.3
		kW	2.20		2.17		2.13		2.07		2.05		1.97		1.85		1.76		1.70		1.54	
	950	TC	11.4	10.5	15.0	13.8	19.9	18.3	23.4	21.4	24.4	22.1	26.5	23.2	27.8	27.8	28.0	28.0	29.8	29.8	37.0	37.0
		kW	2.30		2.27		2.24		2.17		2.16		2.07		1.94		1.83		1.77		1.57	
70	750	TC	11.2	10.4	11.2	10.3	13.1	12.0	16.6	15.2	17.5	15.9	20.0	17.6	22.0	22.0	22.7	22.7	24.4	24.4	30.9	30.9
		kW	2.34		2.30		2.31		2.27		2.26		2.22		2.14		2.08		2.03		1.90	
	850	TC	10.5	9.7	14.0	12.9	14.7	13.5	18.2	16.6	19.2	17.5	21.7	19.0	23.3	23.3	23.9	23.9	25.6	25.6	32.2	32.2
		kW	2.39		2.35		2.36		2.32		2.32		2.26		2.16		2.08		2.03		1.87	
	950	TC	11.2	10.4	12.4	11.4	16.5	15.1	20.2	18.4	21.0	19.0	23.5	20.6	25.0	25.0	25.3	25.3	27.1	27.1	33.7	33.7
		kW	2.49		2.46		2.46		2.42		2.42		2.37		2.25		2.16		2.10		1.91	
80	750	TC	6.0	5.5	6.6	6.1	8.8	8.1	11.8	10.7	15.1	13.7	17.3	15.1	19.3	19.3	20.1	20.1	21.8	21.8	28.0	28.0
		kW	2.58		2.54		2.54		2.53		2.54		2.52		2.47		2.43		2.39		2.27	
	850	TC	8.6	7.9	9.5	8.8	12.7	11.7	15.1	13.8	16.2	14.7	18.7	16.4	20.6	20.6	21.3	21.3	23.0	23.0	29.2	29.2
		kW	2.63		2.59		2.59		2.58		2.59		2.58		2.50		2.44		2.39		2.23	
	950	TC	9.5	8.8	10.5	9.7	13.9	12.7	16.4	15.0	17.6	15.9	20.3	17.8	22.2	22.2	22.8	22.8	24.4	24.4	30.7	30.7
		kW	2.73		2.69		2.69		2.68		2.69		2.68		2.60		2.52		2.46		2.27	

**LEGEND:**

- TC - Heating Capacity (1000 Btuh) (Includes Indoor-Fan Motor Heat)
- db - Dry Bulb
- kW - Total Power Input (Includes Compressor Motor Power Input)

**NOTES:**

- 1  Indicates integrated ratings
- 2  Integrated capacity is maximum (instantaneous) capacity less the effect of frost on the outdoor coil and the heat required to defrost it



## HEATING EXPANDED PERFORMANCE

Return Air (F db)		CFM (Standard Air)		PHX342 (High Capacity)																		
				Air Temperature Entering Outdoor Coil (F)																		
				-10		0		10		17		20		30		40		47		50		60
60	1225	TC	17.8	16.5	17.8	16.4	20.8	19.1	23.6	21.5	24.9	22.5	29.5	25.8	34.6	34.6	39.2	39.2	41.6	41.6	51.3	51.3
		kW	2.83		2.83		2.86		2.87		2.91		3.04		3.20		3.34		3.38		3.57	
	1400	TC	18.1	16.7	18.1	16.6	23.2	21.2	26.1	23.8	27.1	24.5	31.8	27.8	37.1	37.1	41.6	41.6	44.0	44.0	53.8	53.8
		kW	2.90		2.90		2.92		2.94		2.97		3.10		3.24		3.36		3.39		3.54	
	1575	TC	18.2	16.8	18.2	16.8	22.9	21.0	27.3	24.8	29.1	26.4	34.0	29.8	39.3	39.3	43.7	43.7	46.2	46.2	56.0	56.0
		kW	2.94		2.94		2.96		2.98		3.01		3.14		3.27		3.38		3.39		3.51	

Return Air (F db)		CFM (Standard Air)		PHX342 (Low Capacity)																		
				Air Temperature Entering Outdoor Coil (F)																		
				-10		0		10		17		20		30		40		47		50		60
60	800	TC	8.9	8.2	12.5	11.5	18.4	16.9	23.7	21.6	24.7	22.4	28.2	24.7	29.9	29.9	29.4	29.4	31.8	31.8	40.6	40.6
		kW	2.36		2.48		2.51		2.51		2.48		2.39		2.30		2.26		2.26		2.30	
	900	TC	12.4	11.5	14.2	13.1	20.3	18.6	25.5	23.3	26.5	24.0	29.6	25.9	31.1	31.1	30.4	30.4	32.9	32.9	42.0	42.0
		kW	2.35		2.47		2.51		2.50		2.47		2.36		2.26		2.20		2.20		2.21	
	1000	TC	15.2	14.1	16.8	15.5	22.0	20.2	27.1	24.7	28.3	25.7	30.2	26.5	32.1	32.1	31.4	31.4	33.9	33.9	43.2	43.2
		kW	2.34		2.47		2.50		2.49		2.46		2.33		2.22		2.15		2.15		2.15	
70	800	TC	9.6	8.8	9.6	8.8	14.9	13.7	19.6	17.9	20.9	18.9	24.5	21.5	26.6	26.6	26.5	26.5	28.8	28.8	37.3	37.3
		kW	2.64		2.64		2.72		2.74		2.72		2.63		2.55		2.50		2.51		2.56	
	900	TC	10.6	9.8	11.2	10.3	16.7	15.3	21.4	19.5	22.6	20.5	27.0	23.6	27.7	27.7	27.5	27.5	29.9	29.9	38.6	38.6
		kW	2.42		2.63		2.71		2.73		2.70		2.60		2.50		2.44		2.45		2.47	
	1000	TC	13.0	12.0	12.6	11.6	18.4	16.9	23.2	21.2	24.4	22.1	27.3	23.9	28.7	28.7	28.3	28.3	30.8	30.8	39.7	39.7
		kW	2.41		2.63		2.71		2.72		2.69		2.58		2.46		2.40		2.39		2.40	
80	800	TC	6.4	5.9	6.8	6.2	11.5	10.5	15.9	14.5	16.9	15.4	20.8	18.2	23.3	23.3	23.6	23.6	25.9	25.9	34.1	34.1
		kW	2.47		2.79		2.94		2.98		2.97		2.90		2.82		2.78		2.80		2.86	
	900	TC	8.3	7.7	8.4	7.7	19.0	17.4	17.7	16.1	18.7	17.0	22.2	19.4	24.4	24.4	24.6	24.6	26.9	26.9	35.3	35.3
		kW	2.46		2.79		2.93		2.97		2.95		2.87		2.77		2.72		2.72		2.76	
	1000	TC	7.9	7.3	10.5	9.7	14.8	13.6	19.4	17.7	20.4	18.5	23.5	20.6	25.4	25.4	25.4	25.4	27.7	27.7	36.4	36.4
		kW	2.35		2.78		2.93		2.97		2.95		2.85		2.74		2.67		2.67		2.69	

**LEGEND:**

- TC** - Heating Capacity (1000 Btuh) (Includes Indoor-Fan Motor Heat)
- db** - Dry Bulb
- kW** - Total Power Input (Includes Compressor Motor Power Input)

**NOTES:**

- 1  Indicates integrated ratings
- 2 Integrated capacity is maximum (instantaneous) capacity less the effect of frost on the outdoor coil and the heat required to defrost it

## HEATING EXPANDED PERFORMANCE

Return Air (F db)		CFM (Standard Air)	PHX348 (High Capacity)																			
			Air Temperature Entering Outdoor Coil (F)																			
			-10		0		10		17		20		30		40		47		50		60	
60	1400	TC	14.4	13.3	18.3	16.8	21.4	19.6	24.4	22.3	26.0	23.6	32.1	28.2	39.3	39.3	45.6	45.6	48.4	48.4	59.3	59.3
		kW	2.77		2.85		2.86		2.88		2.94		3.14		3.34		3.52		3.55		3.71	
	1600	TC	14.9	13.8	19.9	18.3	23.8	21.8	26.5	24.2	28.2	25.6	34.7	30.4	42.1	42.1	48.4	48.4	51.2	51.2	62.2	62.2
		kW	2.91		2.91		2.92		2.94		3.00		3.20		3.39		3.55		3.57		3.69	
	1800	TC	13.3	12.3	17.7	16.3	25.5	23.4	28.9	26.4	30.2	27.4	36.9	32.4	44.6	44.6	50.9	50.9	53.7	53.7	64.8	64.8
		kW	2.93		2.93		2.96		2.98		3.04		3.24		3.43		3.57		3.59		3.68	
70	1400	TC	12.1	11.2	16.3	15.0	19.1	17.5	22.1	20.2	23.7	21.5	29.5	25.8	36.3	36.3	42.3	42.3	45.0	45.0	55.3	55.3
		kW	3.12		3.12		3.16		3.16		3.22		3.43		3.66		3.85		3.88		4.04	
	1600	TC	13.9	12.9	18.6	17.1	21.5	19.7	24.2	22.1	25.7	23.3	31.9	28.0	39.0	39.0	45.0	45.0	47.6	47.6	58.0	58.0
		kW	3.18		3.18		3.24		3.22		3.28		3.50		3.71		3.88		3.90		4.02	
	1800	TC	13.9	12.8	18.5	17.0	24.0	22.1	26.5	24.1	27.8	25.2	34.1	29.8	41.5	41.5	47.5	47.5	50.1	50.1	60.6	60.6
		kW	3.22		3.22		3.28		3.27		3.33		3.54		3.75		3.90		3.92		4.01	
80	1400	TC	9.4	8.7	12.6	11.6	16.8	15.4	19.9	18.1	21.3	19.4	26.9	23.6	33.4	33.4	39.2	39.2	41.7	41.7	51.6	51.6
		kW	3.49		3.49		3.49		3.51		3.56		3.77		4.02		4.22		4.25		4.42	
	1600	TC	12.6	11.7	16.8	15.5	19.2	17.7	21.7	19.8	22.4	20.3	29.2	25.6	36.0	36.0	41.8	41.8	44.3	44.3	54.3	54.3
		kW	3.47		3.47		3.56		3.58		3.64		3.84		4.07		4.25		4.28		4.40	
	1800	TC	13.0	12.0	17.3	15.9	21.7	19.9	24.0	21.9	25.3	23.0	31.2	27.3	38.3	38.3	44.3	44.3	46.7	46.7	56.7	56.7
		kW	3.50		3.50		3.59		3.63		3.67		3.88		4.11		4.28		4.29		4.39	

Return Air (F db)		CFM (Standard Air)	PHX348 (Low Capacity)																			
			Air Temperature Entering Outdoor Coil (F)																			
			-10		0		10		17		20		30		40		47		50		60	
60	950	TC	8.5	7.8	10.7	9.8	15.0	13.7	18.5	16.9	19.9	18.0	24.2	21.2	29.0	29.0	32.5	32.5	35.0	35.0	38.5	38.5
		kW	2.29		2.30		2.30		2.27		2.29		2.34		2.39		2.43		2.41		2.13	
	1100	TC	11.7	10.9	12.2	11.2	16.8	15.5	20.6	18.8	21.8	19.8	26.0	22.8	30.6	30.6	34.1	34.1	36.6	36.6	46.1	46.1
		kW	2.29		2.30		2.30		2.26		2.28		2.32		2.34		2.36		2.33		2.26	
	1250	TC	11.5	10.6	14.5	13.3	18.5	17.0	21.2	19.3	23.6	21.4	27.8	24.3	32.2	32.2	35.5	35.5	38.1	38.1	47.8	47.8
		kW	2.25		2.30		2.30		2.27		2.28		2.31		2.32		2.31		2.28		2.18	
70	950	TC	7.3	6.8	8.4	7.7	12.3	11.3	15.6	14.2	17.0	15.4	21.0	18.4	25.7	25.7	29.2	29.2	31.5	31.5	40.3	40.3
		kW	2.45		2.52		2.52		2.50		2.54		2.62		2.69		2.75		2.73		2.70	
	1100	TC	10.3	9.5	9.9	9.1	14.0	12.9	17.5	16.0	18.7	16.9	22.8	20.0	27.4	27.4	30.7	30.7	33.1	33.1	42.1	42.1
		kW	2.44		2.51		2.52		2.50		2.53		2.60		2.65		2.68		2.65		2.58	
	1250	TC	10.8	10.0	13.4	12.3	14.9	13.7	16.4	15.0	17.5	15.9	21.5	18.8	26.2	26.2	34.5	34.5	43.7	43.7	43.7	43.7
		kW	2.41		2.52		2.52		2.50		2.53		2.60		2.62		2.64		2.60		2.50	
80	950	TC	6.1	5.6	6.0	5.5	9.6	8.8	12.6	11.5	13.9	12.6	17.9	15.7	22.5	22.5	25.9	25.9	28.1	28.1	36.6	36.6
		kW	2.59		2.79		2.77		2.76		2.81		2.93		3.03		3.11		3.09		3.08	
	1100	TC	7.1	6.6	7.6	7.0	11.3	10.3	14.5	13.2	15.7	14.2	19.7	17.2	24.0	24.0	27.4	27.4	29.6	29.6	38.3	38.3
		kW	2.78		2.78		2.77		2.76		2.80		2.91		2.99		3.04		3.01		2.96	
	1250	TC	9.7	9.0	9.9	9.1	12.8	11.7	16.1	14.7	17.4	15.7	21.4	18.7	25.5	25.5	28.8	28.8	31.1	31.1	39.8	39.8
		kW	2.57		2.78		2.77		2.76		2.80		2.91		2.96		2.99		2.96		2.87	

**LEGEND:**

- TC** - Heating Capacity (1000 Btuh) (Includes Indoor-Fan Motor Heat)
- db** - Dry Bulb
- kW** - Total Power Input (Includes Compressor Motor Power Input)

**NOTES:**

- 1  Indicates integrated ratings
- 2 Integrated capacity is maximum (instantaneous) capacity less the effect of frost on the outdoor coil and the heat required to defrost it

## HEATING EXPANDED PERFORMANCE

Return Air (F db)		CFM (Standard Air)		PHX360 (High Capacity)																		
				Air Temperature Entering Outdoor Coil (F)																		
				-10		0		10		17		20		30		40		47		50		60
60	1750	TC	11.7	10.8	15.6	14.3	20.7	19.0	27.7	25.2	30.5	27.7	36.8	32.2	46.9	46.9	55.7	55.7	58.9	58.9	71.4	71.4
		kW	3.29		3.29		3.30		3.31		3.43		3.85		4.32		4.70		4.77		5.06	
	2000	TC	8.4	7.8	11.3	10.4	15.2	13.9	20.3	18.5	27.8	25.2	40.3	35.3	49.2	49.2	57.8	57.8	61.1	61.1	74.4	74.4
		kW	2.93		3.00		3.06		3.13		3.31		3.74		4.19		4.54		4.59		4.81	
	2250	TC	8.6	7.9	11.4	10.5	15.2	13.9	20.2	18.4	27.5	25.0	39.6	34.7	52.6	52.6	61.5	61.5	64.5	64.5	76.8	76.8
		kW	3.22		3.25		3.28		3.31		3.45		3.84		4.24		4.57		4.62		4.77	
70	1750	TC	11.0	10.1	14.6	13.5	19.5	17.9	26.0	23.7	28.8	26.1	34.6	30.3	44.1	44.1	52.6	52.6	55.7	55.7	68.2	68.2
		kW	3.60		3.61		3.62		3.63		3.76		4.21		4.73		5.14		5.21		5.49	
	2000	TC	8.0	7.4	10.7	9.9	14.4	13.2	19.2	17.5	26.4	23.9	38.2	33.5	46.9	46.9	54.8	54.8	57.9	57.9	71.0	71.0
		kW	3.29		3.35		3.41		3.47		3.65		4.11		4.58		4.97		5.02		5.24	
	2250	TC	8.0	7.4	10.6	9.8	14.1	13.0	18.8	17.1	25.6	23.2	36.9	32.3	50.1	50.1	59.0	59.0	61.8	61.8	73.5	73.5
		kW	3.56		3.59		3.61		3.64		3.78		4.21		4.64		5.00		5.04		5.20	
80	1750	TC	10.3	9.5	13.7	12.6	18.2	16.7	24.3	22.2	27.0	24.4	33.1	29.0	41.3	41.3	49.5	49.5	52.6	52.6	65.5	65.5
		kW	3.93		3.95		3.96		3.97		4.12		4.61		5.18		5.63		5.70		5.97	
	2000	TC	7.5	6.9	10.1	9.3	13.5	12.4	18.1	16.5	24.8	22.5	35.9	31.5	45.1	45.1	52.5	52.5	55.4	55.4	68.2	68.2
		kW	3.67		3.73		3.78		3.84		4.02		4.52		5.03		5.44		5.49		5.72	
	2250	TC	7.2	6.6	9.5	8.8	12.7	11.6	16.8	15.3	22.9	20.8	33.1	29.0	47.4	47.4	56.5	56.5	59.5	59.5	70.4	70.4
		kW	3.82		3.86		3.90		3.95		4.12		4.60		5.09		5.46		5.50		5.66	

Return Air (F db)		CFM Standard Air		PHX360 (Low Capacity)																		
				Air Temperature Entering Outdoor Coil (F)																		
				-10		0		10		17		20		30		40		47		50		60
60	1125	TC	11.8	10.9	15.8	14.5	19.7	18.1	23.0	21.0	24.4	22.2	29.9	26.2	36.4	36.4	41.8	41.8	44.6	44.6	55.4	55.4
		kW	2.95		2.90		2.85		2.82		5.54		14.59		23.83		30.62		30.85		31.96	
	1300	TC	12.3	11.3	16.4	15.0	21.8	20.0	25.0	22.8	26.3	23.9	31.6	27.7	38.1	38.1	43.6	43.6	46.5	46.5	57.7	57.7
		kW	2.93		2.88		2.83		2.79		5.47		14.25		23.03		29.36		29.48		30.16	
	1475	TC	14.5	13.4	16.8	15.5	25.7	23.6	27.0	24.6	28.4	25.7	33.4	29.3	39.7	39.7	45.2	45.2	48.1	48.1	59.6	59.6
		kW	2.94		2.89		2.83		2.78		5.43		14.04		22.48		28.46		28.49		28.87	
70	1125	TC	11.0	10.1	14.6	13.4	17.3	15.9	20.4	18.6	21.8	19.8	27.1	23.8	33.4	33.4	38.5	38.5	41.2	41.2	51.6	51.6
		kW	3.28		3.24		3.20		3.17		6.23		16.44		26.88		34.55		34.81		36.02	
	1300	TC	15.1	14.0	20.2	18.6	19.4	17.8	22.5	20.5	23.8	21.6	28.8	25.2	35.0	35.0	40.2	40.2	43.0	43.0	53.7	53.7
		kW	3.30		3.24		3.18		3.14		6.16		16.09		26.03		33.20		33.34		34.10	
	1475	TC	14.0	13.0	18.7	17.2	25.0	22.9	24.5	22.4	25.8	23.4	30.6	26.8	36.5	36.5	41.7	41.7	44.6	44.6	55.6	55.6
		kW	3.30		3.24		3.19		3.13		6.13		15.88		25.45		32.25		32.30		32.71	
80	1125	TC	10.5	9.7	13.9	12.8	14.8	13.6	17.8	16.3	19.1	17.3	24.3	21.3	30.4	30.4	35.2	35.2	37.7	37.7	47.7	47.7
		kW	3.63		3.61		3.58		3.55		7.00		18.49		30.28		38.93		39.21		40.66	
	1300	TC	6.3	5.9	8.5	7.8	19.0	17.4	15.0	13.7	19.9	18.0	25.9	22.7	32.0	32.0	36.8	36.8	39.5	39.5	49.9	49.9
		kW	3.49		3.48		3.48		3.48		6.86		18.12		29.37		37.49		37.64		38.59	
	1475	TC	13.6	12.6	18.1	16.7	24.2	22.2	23.0	21.0	23.1	21.0	27.8	24.3	33.5	33.5	38.4	38.4	41.1	41.1	51.6	51.6
		kW	3.67		3.62		3.57		3.52		6.90		17.92		28.76		36.47		36.53		37.05	

**LEGEND:**

- TC** - Heating Capacity (1000 Btuh) (Includes Indoor-Fan Motor Heat)
- db** - Dry Bulb
- kW** - Total Power Input (Includes Compressor Motor Power Input)

**NOTES:**

- 1  Indicates integrated ratings
- 2 Integrated capacity is maximum (instantaneous) capacity less the effect of frost on the outdoor coil and the heat required to defrost it

## ACCESSORIES

### ROOF CURBS

Model Number	Height (K)	Use With Model Size
AXB020CLA	8"	36
AXB020CMA	14"	
AXB020CHA	24"	
AXB030CLA	8"	42, 48, 60
AXB030CMA	14"	
AXB030CHA	24"	

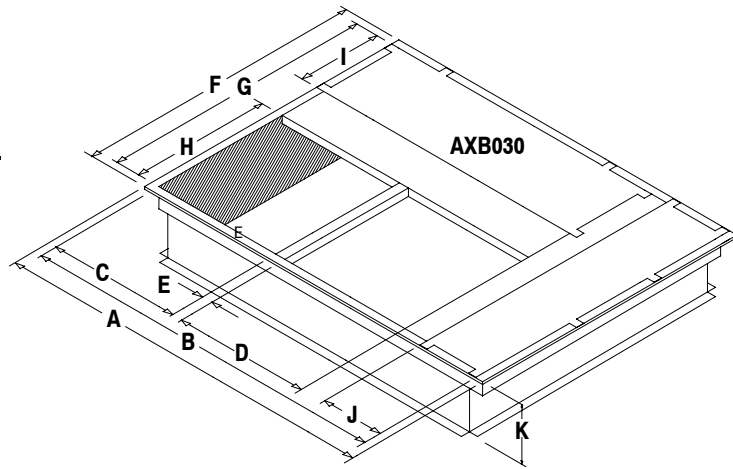
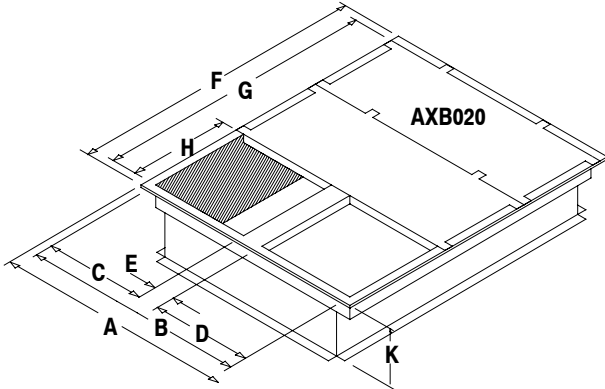

### ROOF CURB DIMENSIONS (inches)

Model Number	A	B	C	D	E	F	G	H	I	J	K (LA)	K (MA)	K (HA)
AXB020(L,M,H)A	42-3/4	39-3/4	18	18	3-3/4	42-3/4	39-3/4	18	-	-	8	14	24
AXB030(L,M,H)A	67-3/4	64-3/4	23	23	2-1/2	42-3/4	39-3/4	23	12	12	8	14	24

### SQUARE to ROUND TRANSITION

Model Number	Round Size	Use With Roof Curb	Use With Model Size
AXB020CTA	16"	AXB020CLA, AXB020CMA, AXB020CHA	36
AXB030CTA	18"	AXB030CLA, AXB030CMA, AXB030CHA	42, 48, 60

### CONCENTRIC GRILLE - FLUSH MOUNT

Model Number	Use With Roof Curb	Use With Model Size
AXB020CFA	AXB020CLA, AXB020CMA, AXB020CHA	36
AXB030CFA	AXB030CLA, AXB030CMA, AXB030CHA	42, 48, 60

### CONCENTRIC GRILLE - STEP DOWN

Model Number	Use With Roof Curb	Use With Model Size
AXB020CSA	AXB020CLA, AXB020CMA, AXB020CHA	36
AXB030CSA	AXB030CLA, AXB030CMA, AXB030CHA	42, 48, 60

## ACCESSORIES

### ECONOMIZERS (ALL FULLY MODULATING)\*

Part Number	Application	Motion	Control	Use With Model Size
AXB020HED	Horizontal	Fully Modulating w/ Return Air Damper w/ Relief Damper	Enthalpy	36
AXB030HED				42, 48, 60
AXB020EMD	Downflow			36
AXB030EME				42, 48, 60
AXB020HPE	Horizontal	Fully Modulating w/ Return Air Damper w/ Relief Damper	Dry Bulb Only	36
AXB030HPE				42, 48, 60
AXB020EPE	Downflow			36
AXB030EPF				42, 48, 60

\* Three position economizers no longer available.

### 0% - 25% FRESH AIR DAMPERS (use in DOWNFLOW application only) \*

Model Number	Control	Use With Model Size
AXB020FAC	Manual	36
AXB030FAC		42, 48, 60
AXB020FMC	Motorized	36
AXB030FMC		42, 48, 60

\* Unit must have internal filters to protect evaporator coil when Fresh Air Damper is installed.

### FILTER RACK and FILTER \*

Model Number	Application	Filter Location	Filter Size	Use With Model Size
AXB020FKA	Downflow	Internal	18 x 25 x 1	36
AXB020FHC	Horizontal	External	20 x 25 x 1	

\* Model size 36 shipped WITHOUT Filter Racks or Filters.

Model sizes 42, 48, and 60 shipped WITH Internal Filter Racks with (2) - 20 x 30 x 2 filters.

### LOW AMBIENT CONTROL

FAST Part Number	Description	Use With Model Size
1148232	Freeze 'stat, opens 30°F, closes 50°F	ALL
ALA14CU0A	R-410A Low Ambient Control	ALL

### COIL PROTECTION

FAST Part Number	Description	Use With Model Size
1149485	Coil Guard, black, two-piece	36
1068133	Hail Guard, black, two-piece	36
1149486	Coil Guard, black, three-piece	42, 48, 60
1068134	Hail Guard, black, three-piece	42, 48, 60

### OUTDOOR THERMOSTAT

Model Number	Description	Use With Model Size
AMF002OTA	2 Stage, Electronic	ALL

# UNIT DIMENSIONS

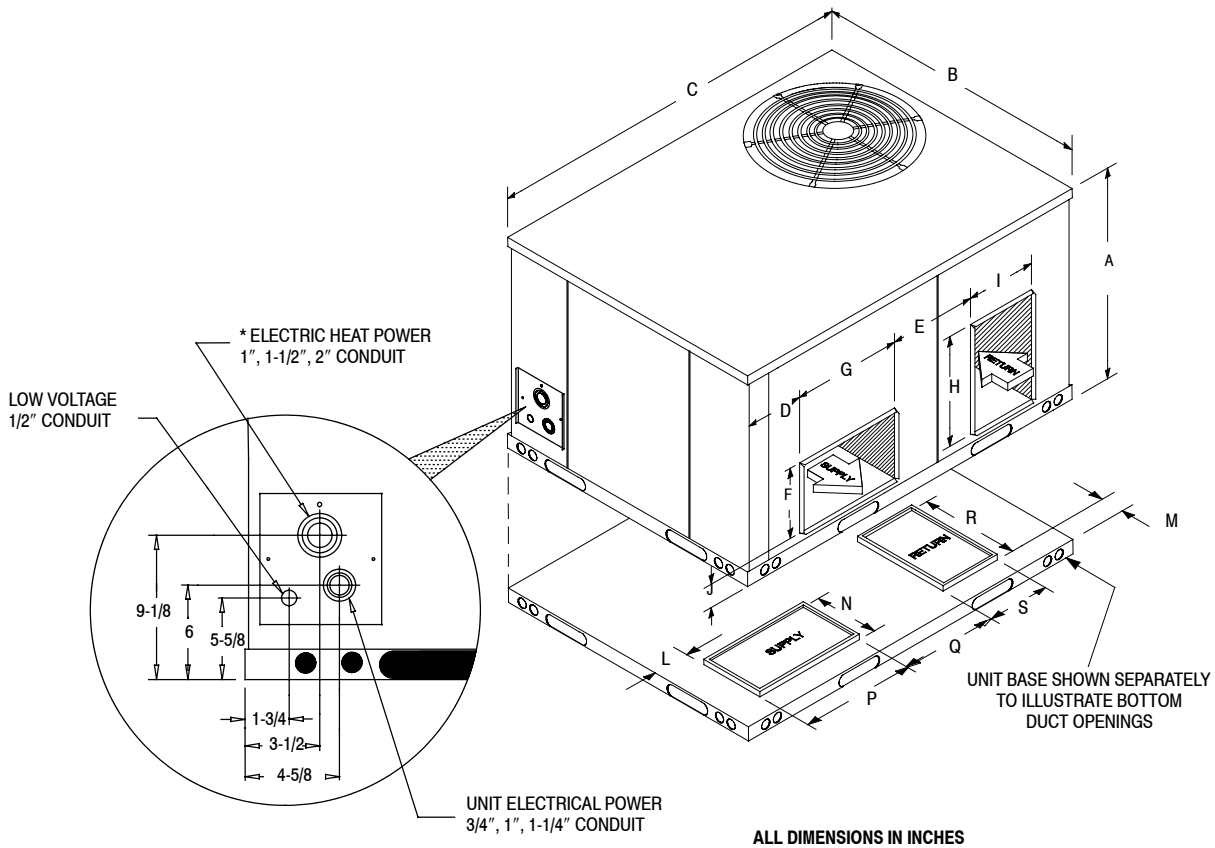

Model Size	A	B	C	D	E	F	G	H	I	J	K	L	M	N**	P**	Q	R	S	Bottom L x W * Inside Base Rail
3 Ton	32-1/2	47-3/8	47-3/8	3-1/8	11-1/8	12	14-1/4	14-1/4	12	4	*	4-1/4	4-3/8	14-1/2	12-1/4	12-1/8	14-1/4	12-1/4	43-1/8 x 43-1/8
3 1/2, 4, 5 Ton	36	47-3/8	73	4-5/8	15	12	18-3/4	18-3/4	12	4	*	4-1/4	5-1/4	12-1/4	19	15	19	12-1/4	68-3/4 x 43-1/8

\*\* The supply opening in the drawing is shown for the orientation in the 3-1/2 to 5 Ton units. The opening for the 3 Ton unit is rotated 90°, so the N and P dimensions are correct.

## MODEL NUMBER IDENTIFICATION GUIDE

Product Family	SEER	Nominal Cooling Capacity Btuh	Heating Input Btuh	Voltage	Option Code	Design Code	Eng. Rev. Code
PHX - Package Air Conditioner, R-410A	3 = 13	36 = 36,000 42 = 42,000 48 = 48,000 60 = 60,000	000 = N/A	H = 208/230-3-60 L = 460-3-60	00 = N/A	A	1
Example: PHX	3	36	000	H	00	A	1

## GUIDE SPECIFICATIONS

### CABINET

The cabinet is made of G-90 galvanized steel, phosphate coated with a tough acrylic finish coat for long lasting weatherproof construction. The base rails are 18 gauge steel with fork lift slots and holes provided for lifting shackles. The unit is designed with convertible airflow for either horizontal or downflow applications with conversion accomplished by relocating two panels. Indoor blower compartment interior cabinet surfaces are insulated with a minimum 3/4" thick, flexible glass insulation, coated on the air side.

### COOLING SECTION

The unit is factory charged and operationally ready upon delivery. The unit refrigerant circuit has a high efficiency fully hermetic compressor with internal overload protection, and copper tube / aluminum fin evaporator and condenser coils. The unit is designed for cooling operation to 40° F and will be capable of being wired for field installed economizer type accessories.

### COILS

The evaporator and condenser coils are fabricated with aluminum fins mechanically bonded to copper tubing. Both coils are pressure tested prior to assembly into the unit and electronically leak tested after assembly into the unit.

### CONDENSER FAN

The unit has a single direct-drive propeller-fan / motor assembly. The assembly is mounted directly to a vertical-discharge grille that is easily removed for service. Motors are 1100 RPM with sleeve or ball bearings and internal overload protection.

### EVAPORATOR BLOWER

All units have a direct-drive evaporator blower motor as a standard. The direct-drive evaporator blower motor has sleeve bearings and internal overload protection.

## INSTALLATION CLEARANCES

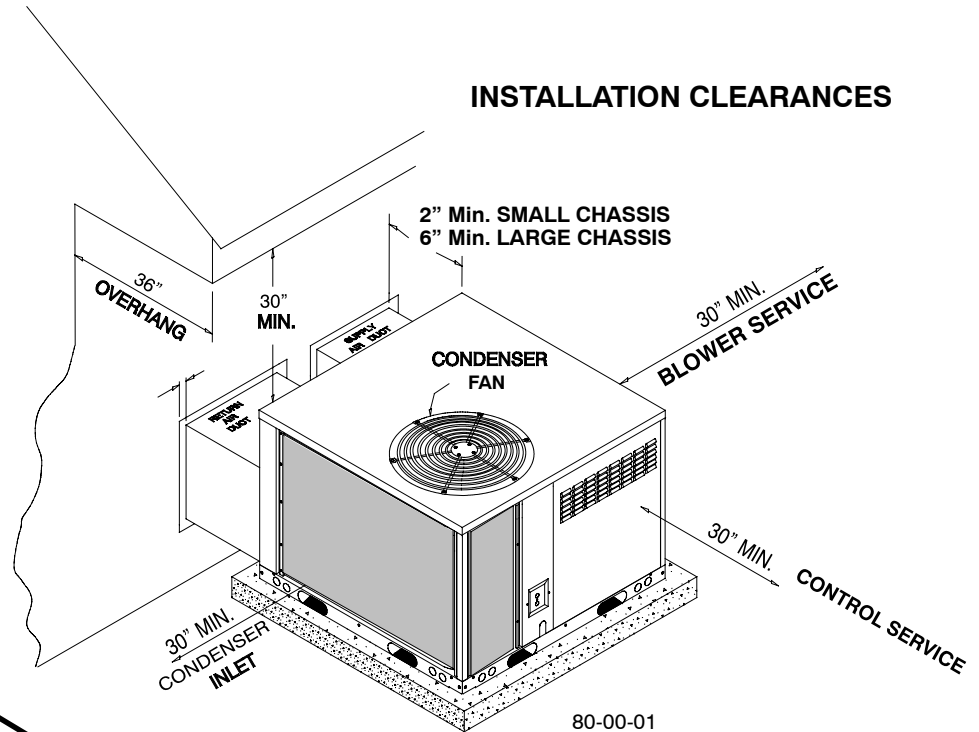

## RIGGING DETAILS

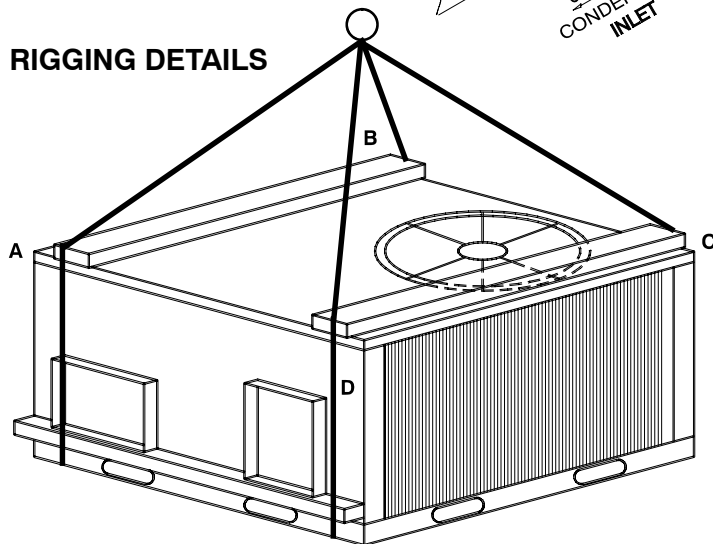

## OPERATING WEIGHTS (LBS)

MODEL	OPERATING WEIGHT TOTAL
PHX336	439
PHX342	560
PHX348	630
PHX360	646