

Electric Heat Accessory

Installation Instructions

EHK05AKN/B, EHK07AKN/B, EHK10AKN/B, EHK15AKF/B, EHK20AKF/B,
EHK15AHN, EHK18AHN, EHK09AKCN, EHK25AHCF, EHK30AHCF

Safety Labeling and Signal Words

DANGER, WARNING, CAUTION, and NOTE

The signal words **DANGER**, **WARNING**, **CAUTION**, and **NOTE** are used to identify levels of hazard seriousness. The signal word **DANGER** is only used on product labels to signify an immediate hazard. The signal words **WARNING**, **CAUTION**, and **NOTE** will be used on product labels and throughout this manual and other manuals that may apply to the product.

DANGER – Immediate hazards which **will** result in severe personal injury or death.

WARNING – Hazards or unsafe practices which **could** result in severe personal injury or death.

CAUTION – Hazards or unsafe practices which **may** result in minor personal injury or product or property damage.

NOTE – Used to highlight suggestions which **will** result in enhanced installation, reliability, or operation.

Signal Words in Manuals

The signal word **WARNING** is used throughout this manual in the following manner:



WARNING

The signal word **CAUTION** is used throughout this manual in the following manner:



CAUTION

Signal Words on Product Labeling

Signal words are used in combination with colors and/or pictures on product labels.

WARNING

ELECTRICAL SHOCK HAZARD.

Failure to follow this warning could result in death and/or personal injury.

Installation or repairs made by unqualified persons can result in hazards to you and others. Installation must conform with local building codes or, in the absence of local codes, with National Electrical Code ANSI/NFPA 70-1996 or current edition.

The information contained in this manual is intended for use by a qualified service technician familiar with safety procedures and equipped with the proper tools and test instruments.

Shut OFF electric power at unit disconnect and/or service panel before beginning the following procedures.



CAUTION

UNIT DAMAGE HAZARD.

Failure to follow this caution may result in property damage.

Before installation of heater, the black and yellow pigtail leads must be removed from the fan coil board or wire harness to prevent possible damage to the product. Electrical power will be provided to the board through the heater circuit plug.

INSTALLATION

INSTALL ELECTRIC HEATER ASSEMBLY

NOTE: Ensure heater coils are not deformed or damaged during heater installation.

1. Make sure power to unit is off.
2. Remove blower access panel of fan coil unit.

3. Disconnect 2 power wires (black and yellow pigtail leads) from fan control board or wire harness (if applicable) and discard. Wires may be part of a plug assembly or attached to terminals L1 and L2. Remove cooling control plate from fan coil (if equipped). For 18kW, 24kW, and 30kW heaters, remove adapter plate. (See Figure 1)
4. Insert heater assembly into front of fan coil so that element rods engage holes in rear heat shield.
5. Attach heater control plate to fan coil using 2 screws provided. For 18kW, 24kW, and 30kW heater models, attach front of heater to fan deck using third screw. (See Figure 1)

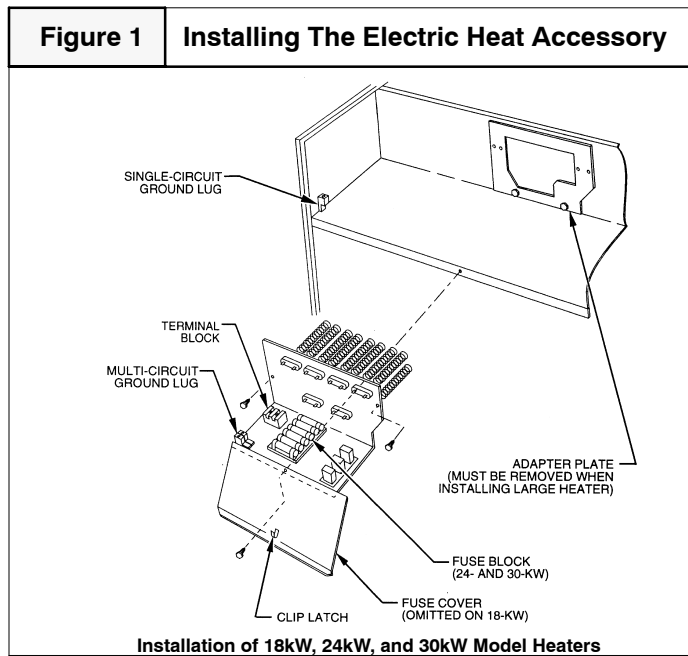

Table 1 - Accessory Heater Usage

Part Number	Description	Use with Model Sizes
EHK05AKN	5 kW, single phase, no internal circuit protection	ALL
EHK05AKB	5 kW, single phase, with circuit breakers	ALL
EHK07AKN	8 kW, single phase, no internal circuit protection	ALL
EHK07AKB	8 kW, single phase, with circuit breakers	ALL
EHK09AKCN	9 kW, supplied as single phase, field convertible to 3-phase, no internal circuit protection	3600, 4800, 6000
EHK10AKN	10 kW, single phase, no internal circuit protection	ALL
EHK10AKB	10 kW, single phase, with circuit breakers	ALL
EHK15AKF	15 kW, single phase, with fuses	ALL
EHK15AKB*	15 kW, single phase, with circuit breakers	ALL†
EHK15AHN	15 kW, 3-phase, no internal circuit protection	ALL†
EHK18AHN	18 kW, 3-phase, no internal circuit protection	4800, 6000
EHK20AKF	20 kW, single phase, with fuses	ALL†
EHK20AKB*	20 kW, single phase, with circuit breakers	ALL†
EHK25AHCF	24 kW, supplied as 3-phase, field convertible to single phase, with fuses	4800, 6000
EHK30AHCF	30 kW, supplied as 3-phase, field convertible to single phase, with fuses	4800, 6000

* EHK15AKB & EHK20AKB are not approved for use in Canada (must use fused heaters and certified single point wiring kit).

† 15kW & 20kW are not recommended for specific heat pump applications, see AIRFLOW DELIVERY (CFM)

Minimum CFM when using Electric Heat (motor speed Low except as noted)

EBP, EBX, EBXX, EBW FEM, FSM, FSU Model Size	Heater kW								
	5	8	9	10	15	18	20	24	30
1800	525*	525*	-	600☆	-	-	-	-	-
2400	700‡	700‡	-	700‡	775‡	-	-	-	-
3000	875	875	-	875	875	-	1060*	-	-
3500 & 3600	1050	970	970	970	920	-	1040	-	-
4200	-	1225	1225	1225	1225	1225	1225	-	-
4800	-	1400	1400	1400	1400	1400	1400	1400	1400
6000	-	1750	1750	1750	1750	1750	1750	1750	1750

☆ Indicates High speed (Black wire) for 2-speed motor.

* Indicates Medium speed (Blue wire) for 3-speed motor or High speed (Black wire) for 2-speed motor

‡ Indicates Medium speed (Blue wire) for 3-speed motor or Low speed (Red wire) for 2-speed motor

STATIC PRESSURE CORRECTION FOR ELECTRIC HEATERS (EBP, EBW, EBX, EBXX, EBV, FEM, FSM, FSU, FVM)

Due to higher static pressure drop with additional electric heater elements in some application, an adjustment table to the static pressure is provided in the Installation and Operations Manual or the Product Specifications.

AIRFLOW DELIVERY (CFM)													
EBV/FVM Model Size	Outdoor Unit Capacity (BTUH)	Electric Heater kW Range											
		0 - 5			0 - 10			0 - 15			0 - 20		
		LO	NOM	HI	LO	NOM	HI	LO	NOM	HI	LO	NOM	HI
2400	18	625	625	625	675	675	675	*	*	*	*	*	*
	24	650	725	835	*	725	835	875	875	875	*	*	*
	30	815	905	1040	*	905	1040	900	900	1040	1100	1100	1100
	36	980	1085	1250	980	1085	1250	980	1085	1250	1100	1100	1250
3600	24	675	725	835	875	875	*	*	*	*	*	*	*
	30	815	905	1040	875	905	1040	1100	1100	1100	*	*	*
	36	980	1085	1250	980	1085	1250	1100	1100	1250	1225	1225	1250
	42	1140	1270	1460	1140	1270	1460	1140	1270	1460	1225	1270	1460
		0 - 10			0 - 15			0 - 20			0 - 30		
4800	30	975	975	1040	1100	1100	1100	*	*	*	*	*	*
	36	980	1085	1250	1100	1100	1250	1250	1250	1250	*	*	*
	42	1140	1270	1460	1140	1270	1460	1250	1270	1460	*	*	*
	48	1305	1450	1665	1305	1450	1665	1305	1450	1665	1500	1500	1665
6000	36	1100	1100	1250	1350	1350	1350	*	*	*	*	*	*
	42	1140	1270	1460	1350	1350	1460	1525	1525	1525	*	*	*
	48	1305	1450	1665	1350	1450	1665	1525	1525	1665	1750	1750	1750
	60	1630	1810	2085	1630	1810	2085	1630	1810	2085	1750	1810	2085

* Airflow not recommended for heater/system size

NOTE: LO, NOM, and HI refer to AC/HP CFM ADJUST selection on the control board.

HEAT PUMP MINIMUM CFM WHEN USING ELECTRIC HEAT (CFM)						
EBV/FVM Model Size	Outdoor Unit Size	Heater Size kW				
		5	8, 9, 10	15	18, 20	24, 30
2400	18	625	625	--	--	--
	24	650	725	875	--	--
	30	800	875	875	1040	--
	36	970	970	970	1040	--
3600	24	675	875	--	--	--
	30	800	875	1100	1150	--
	36	975	975	1100	1225	--
	42	1125	1125	1125	1225	--
4800	30	800	875	875	1150	--
	36	975	975	1100	1225	--
	42	1125	1125	1125	1225	--
	48	1305	1305	1305	1305	1400
6000	36	1100	1100	1350	1350	--
	42	1125	1125	1350	1350	--
	48	1300	1300	1350	1465	1750
	60	1625	1625	1625	1750	1750

A/C MINIMUM CFM WHEN USING ELECTRIC HEAT (CFM)

FVM Model Size	Heater Only	Heater Size kW				
		5	8, 9, 10	15	18, 20	24, 30
2400		625	625	725	875	--
3600		675	700	850	1050	--
4800		675	700	850	1050	1400
6000		1050	1050	1050	1050	1750

NOTES:

1. Heater Only-Air conditioner with electric heater application.

2. These airflows are minimum acceptable airflows as UL listed. Actual airflow delivered will be per airflow delivery chart for Electric Heating Modes.

ATTACH FUSE BOX OR CIRCUIT BREAKER BOX

1. For 15kW and 20kW fused models:

After installing heater assembly, attach fuse assembly to side of fan coil unit by inserting fuse box tab between insulation and to left side of unit and fan deck. Mount front of assembly to side flange with two (2) screws provided. On fan coil units size 4200 and larger, remove wire tie that shortens wire length between heater and fuses. Fuse cover is closed by engaging dimples in fuse box. (See Figure 2)

2. For 24kW and 30kW fused models:

Fuse assembly is mounted on heater. Be sure fuse cover is closed by engaging clip latch on unit top panel. (See Figure 1)

⚠ WARNING

ELECTRICAL SHOCK.

Failure to follow this warning could result in death and/or personal injury.

Close fuse box before power is turned to ON position.

3. For 5kW through 20kW circuit breaker models:

After installing heater assembly, attach circuit breaker assembly to unit with screws provided. (See Figure. 3) On fan coil units size 4200 and larger, remove wire tie that shortens wire length between heater and circuit breaker assembly to allow mounting of circuit breaker assembly. (See Figure 3)

4. Circuit breaker models require installing a bezel in unit door to provide safe access to circuit breakers. Bezel mounts on inside of blower door. (See Figure 4)

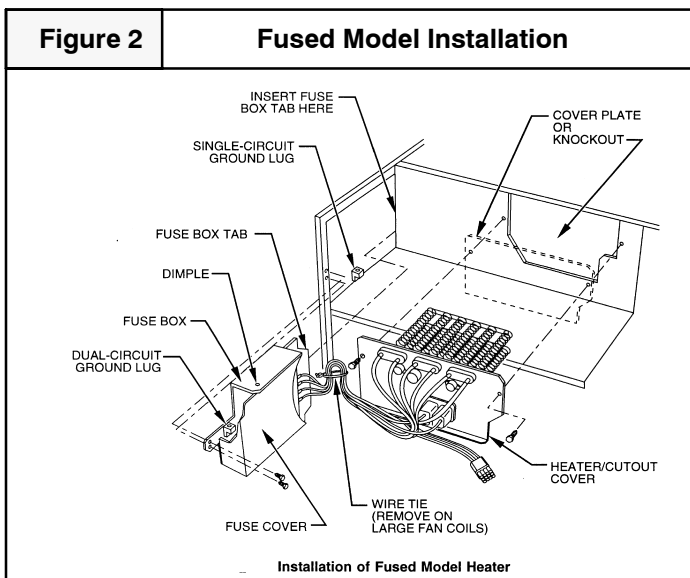

- a. Cut insulation away from access hole in blower access panel. Slide bezel flanges under insulation. Lip on bezel must protrude inward toward unit.

- b. Secure bezel to panel with two (2) No. 6 hex head screws. Insert screws through original cover plate holes on access panel and drive into engagement holes on bezel flanges.

ELECTRICAL CONNECTIONS

Refer to unit instructions for recommended wiring procedures. Install wiring in accordance with all applicable local and national codes.

Connect heater wiring harness plug to receptacle on fan control board or wire harness. A positive connection must be made between plug and receptacle. Plug will interlock with receptacle when properly seated. Harness contains both 24V control and high-voltage wiring. Blower power is provided through heater harness.

NOTE: Units with or without electric heaters require a minimum CFM. Refer to unit wiring label to ensure the fan speed selected with electric heaters is equal to or greater than the minimum fan speed indicated. The minimum CFM for cooling is determined by the outdoor unit requirements. Use the higher of the two for year-round operation.

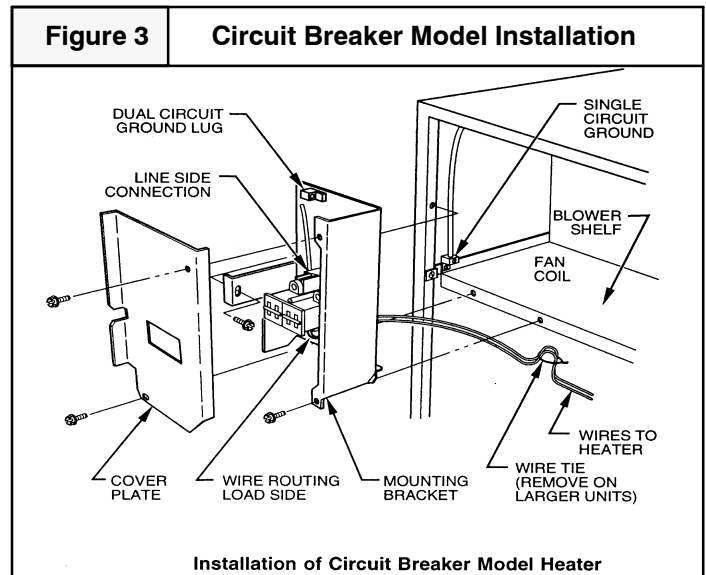

A. Wire 24V Control Systems

1. Connections to unit

Use No. 18 AWG color-coded, insulated (35 Deg. C minimum) wire to make low-voltage connections between thermostat, fan coil unit, and outdoor unit. If thermostat is located more than 100 ft. from unit (as measured along the low-voltage wire), use No. 16 AWG color-coded, insulated (35 Deg. C minimum) wire. All wiring must be separated from line voltage power leads. Refer to outdoor unit wiring instructions for additional wiring procedure recommendations.

2. Transformer

Transformer is factory wired for 230V operation. For 208V applications, disconnect black wire on transformer 230V terminal and reconnect it to 208V terminal. (See Figure 5) The secondary circuit of transformer is protected by a 5-amp fuse mounted on fan control board.

3. Heater staging

The units are shipped circuited for single stage operation. The heat can be staged either through an indoor thermostat or by using an outdoor thermostat. When two stages are desired, cut W3 at the W2 wire nut, strip and reconnect per wiring staging layout in Installation Instructions for fan coils.

- a. The 5kW, 8kW, and 10kW heaters are single stage only.
 - b. The 9kW and 15kW heaters are adaptable for two stage operation.
 - c. The 18kW, 20kW, 24kW, and 30kW heaters are adaptable for three stage operation.
- ### 4. Rectifier and Time Delay Boards

Each heater element is controlled by a relay mounted on the heater panel. The relay has a 24V DC coil. Each relay has a small rectifier board attached directly to relay coil terminals. The rectifier board converts incoming 24V AC control signal to DC. Some heaters may have up to three relays. The second and/or third relay rectifier board also has a time delay feature and a small jumper wire built into it. With the jumper uncut, the time delay allows the second stage heat to be energized approximately five (5) seconds after the first stage. On 18kW, 24kW, and 30kW heaters, the third stage relay board jumper is cut at factory. This provides an eight (8) second delay after first stage relay closes.

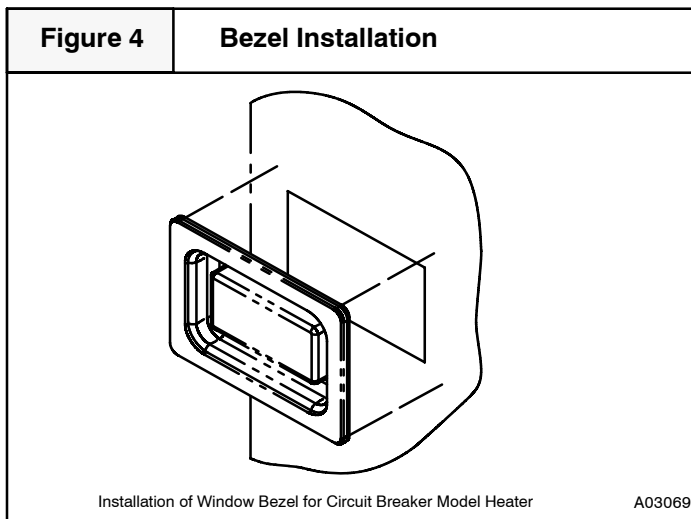

B. Power Connections

NOTE: Heater supply circuit wire size and overcurrent protection must comply with National Electrical Code (NEC) and UL branch circuit requirements. (See Table 3) Wires and overcurrent protection, integral to the heater, are not required to meet branch circuit requirements. Internal circuit protection of 60 amps (maximum) is acceptable.

1. Unprotected heaters: (See Figures 6, 10, and 11)
 - a. The 5kW through 10kW single phase and 15kW and 18kW three phase heaters can be wired for single supply circuit only. Supply circuit connects to heater pigtail leads (terminal block on 18kW heaters).
 - b. The 5kW through 10kW single phase heaters can use a separate field-installed, factory-authorized disconnect kit which installs in fan coil.

NOTE: Refer to wiring label for component locations.

- c. The 9kW heater is factory wired for single supply circuit, single phase. To convert heater to single supply circuit, three phase:

- (1.) Disconnect blue wire from limit switch (LS3). Cut, strip, and connect to field wire L3.
- (2.) Disconnect yellow wire from LS1 and connect to LS3.
- (3.) Disconnect blue wire from relay 2, terminal 2 and connect to LS1.

2. Circuit breaker heaters: (See Figures 7 and 9)

- a. The 5kW through 10kW heaters can be wired for single-supply circuit only.
 - b. The 15kW and 20kW heaters can be wired for dual-supply circuits only.

3. Fused heaters: (See Figures 8, 12, 13, and 14)

- a. The 15kW and 20kW heaters can be wired for single or dual supply circuits. Single supply circuit wiring requires a factory authorized, single-point adapter kit.
 - b. The 24kW and 30kW heaters can be wired for single or multiple supply circuits. Heaters are factory wired for single circuit three phase. To convert heaters to single circuit single phase, disconnect yellow lead from L3 and connect to L1. Disconnect black lead from L3 and connect to L2. To convert heaters to multiple supply circuit single phase, remove and discard leads between single circuit terminal block and fuse block. Remove and discard single circuit terminal block. Attach L1 through L6 power leads as indicated on label next to fuse block.

C. Ground Connections

	WARNING
ELECTRICAL SHOCK.	
Failure to follow this warning could result in property damage and/or death.	
According to NEC, ANSI/NFPA 70, and local codes, cabinet must have an uninterrupted or unbroken ground to minimize personal injury if an electrical fault should occur. The ground may consist of electrical wire or metal conduit when installed in accordance with existing electrical codes. (See Ground/Conduit Note below.)	

NOTE: Use UL-listed conduit and conduit connector for connecting supply wire(s) to unit to obtain proper grounding. If conduit connection uses reducing washers, a separate ground wire must be used. Grounding may also be accomplished by using grounding lugs provided in control box.

1. For unprotected or single circuit heaters, 1 equipment ground connection is provided on fan coil unit. (See Figure 1 or 2)
2. For 15kW and 20kW circuit breaker heaters, an additional ground lug is provided on circuit breaker mounting bracket for dual circuit grounding. (See Figure 3)
3. For 15kW and 20kW fused heaters, an additional ground lug is provided on fuse mounting bracket for dual circuit grounding. (See Figure 2)
4. For 24kW and 30kW fused heaters, two (2) additional ground lugs are provided for single phase, multi circuit wiring. (See Figure 1)

D. FAN SPEED SELECTION

FSM, FSU, EBP, EBX, EBXX & EBW Motor Speed Selection

1. Speed tap selection is done at fan relay. To change motor speeds, disconnect fan lead on relay and replace with motor speed tap desired. Save insulating cap and place on motor lead that was removed from relay. (See Figure 15) Refer to table below for further clarification of speed tap selections.

Motor Speed Tap	Wire Color
Common	Yellow
High	Black
Medium	Blue (Factory Selected)
Low	Red (Blue on 2 speed models)

IMPORTANT!

For FEM Motor Speed Selection, refer to installation instructions of the FEM fan coil.

For FVM, Variable Motor Speed Selection, refer to installation instructions of the FVM fan coil.

For EBV Motor Speed Selection, refer to installation instructions of the EBV fan coil.

CONVERSION OF CIRCUIT BREAKER FOR DOWNFLOW APPLICATIONS

1. Tag and disconnect factory wiring from terminals on circuit breaker(s).
2. Pull white plastic release tab on the bottom of circuit breaker straight out to release circuit breaker from bracket. (See Figure 16)
3. Remove quick connect adapters from factory side of breaker(s). Reinstall adapters on other end of breakers(s). Be sure adapter is located between lug screw and plate. Torque lug screw to 30-in.-lb.
4. Rotate breaker 180 degrees from its original position and reinstall in bracket. Slide breaker slot into sheet metal tab and snap breaker into place. Make sure both tabs engage breaker. Reconnect wiring on opposite end. Make sure wires are positioned as before.
5. Remount circuit breaker bracket into unit so that the switch will be in UP position when ON.

ATTACH WIRING DIAGRAM AND RATING LABEL

Attach heater rating label included with kit over existing electrical information label located on front access panel of fan coil. (See Figure 17) If kit contains multiple rating labels, ensure correct label is applied (check phase and supply circuits).

VERIFY INSTALLATION

After completion of heater installation, check wiring to ensure tightness and that proper connections and routings have been made. Ensure all electrical covers are in place and proper labels have been applied. Reinstall blower access panel before turning unit power on.

ADJUSTING THERMOSTAT ANTICIPATOR

Set the heat anticipator of the thermostat to the proper value. Each stage of heat is approximately 0.08 amps per relay. See instructions provided with the thermostat before making this adjustment.

Heater Model (kW)	Anticipator Setting (Approximate Amps)
5, 8, 10 (Single Stage)	.08
9, 15 (Two Stage)	.16
18, 20, 24, 30 (Three Stage)	.24

Figure 5 Connection of Transformer

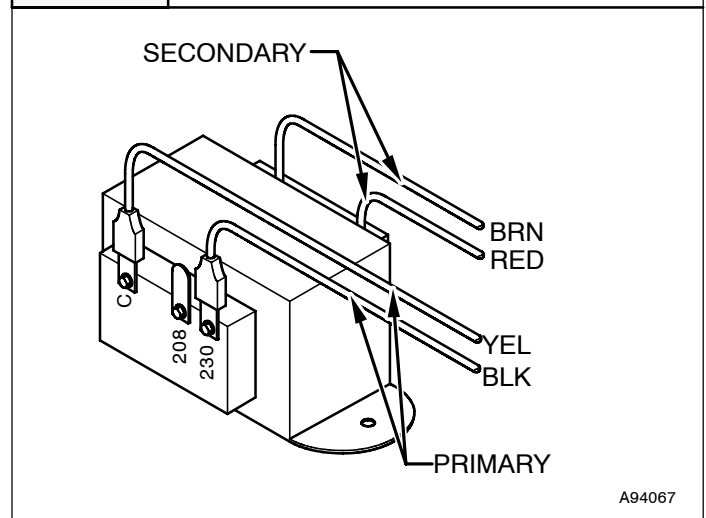

Figure 6 5, 8, 9, and 10 kW Non-fused Heaters

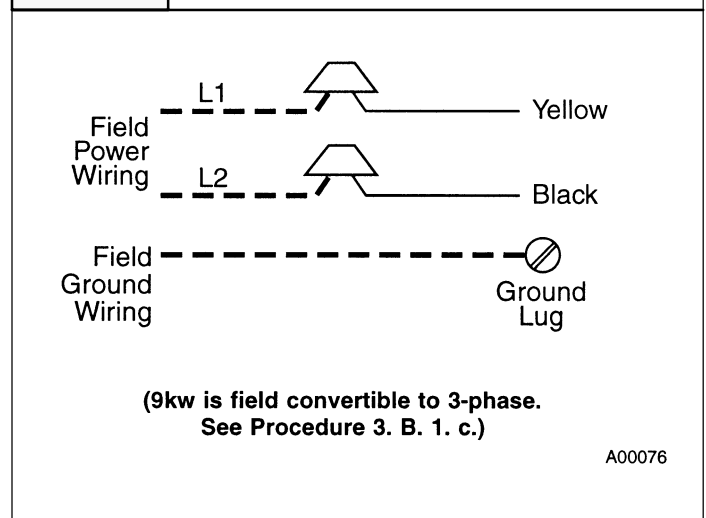

Figure 7 5, 8 and 10 kW Circuit Breaker and Disconnect Heaters

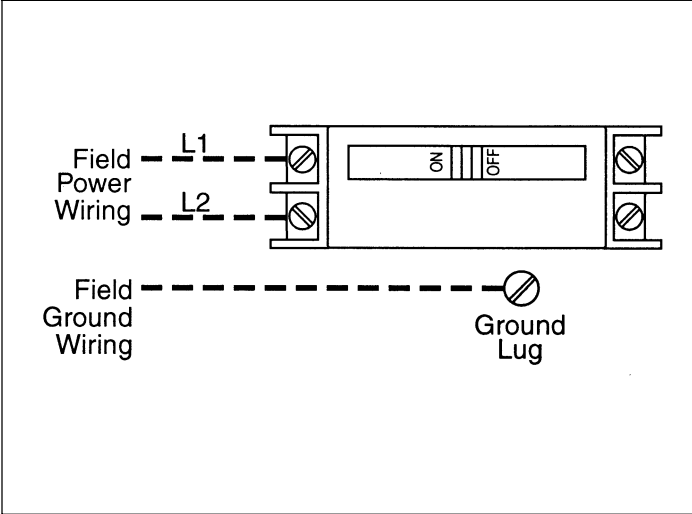

Figure 10 15 kW 3-Phase Heater

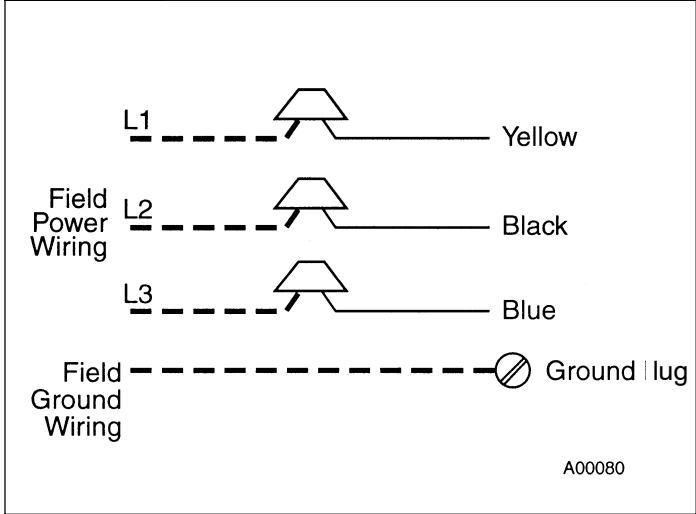

Figure 8 15 and 20 kW Fused Heaters

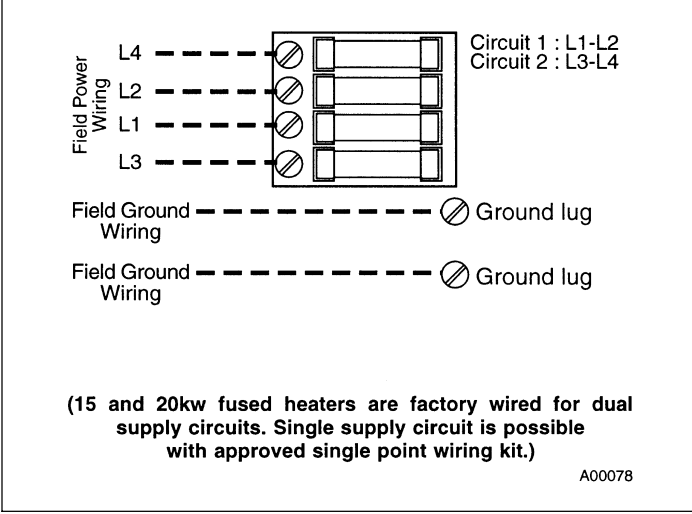

Figure 11 18 kW 3-Phase Heater

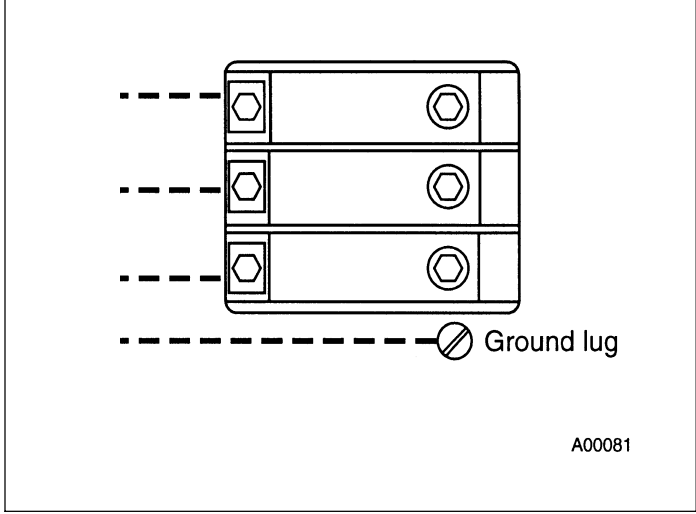

Figure 9 15 and 20 kW Circuit Breakers

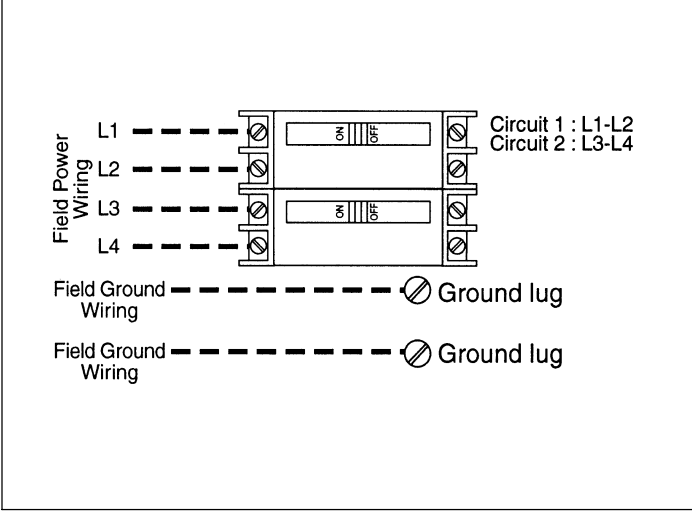

Figure 12 24 and 30 kW Heaters

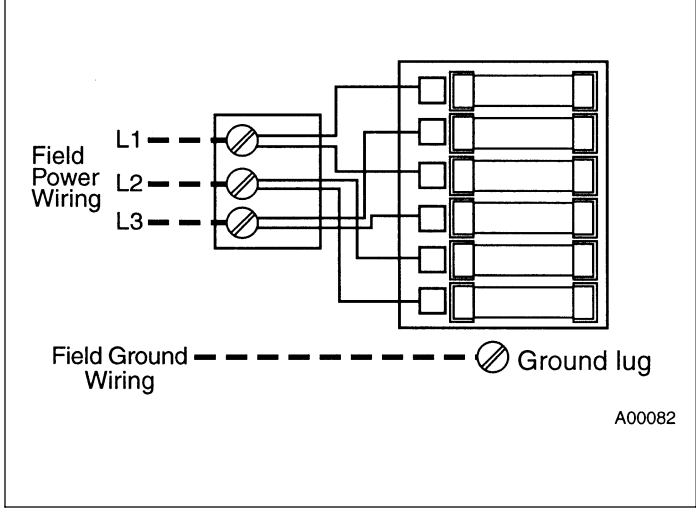

Figure 13 24 and 30 kW Heaters

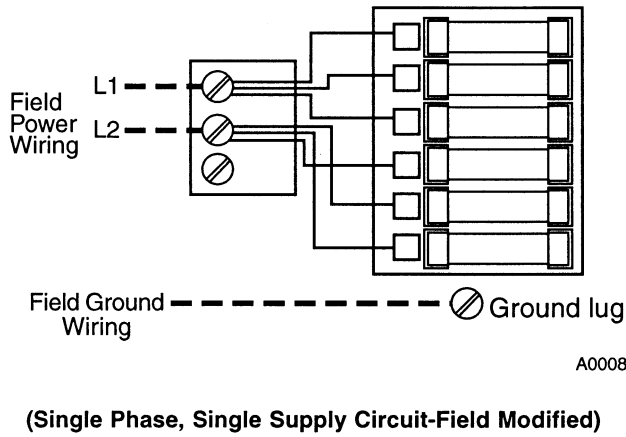

Figure 14 24 and 30 kW Heaters

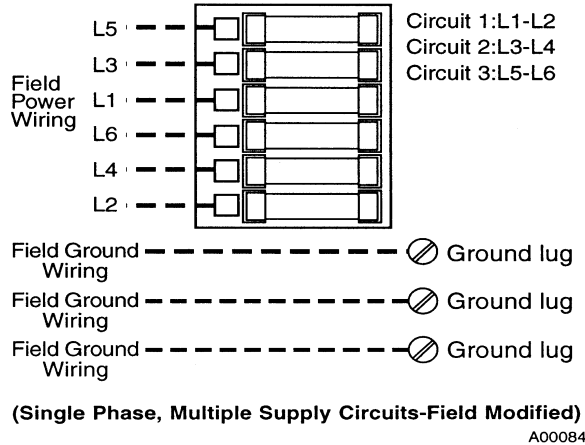

Figure 15 Motor Speed Tap and Fan Relay

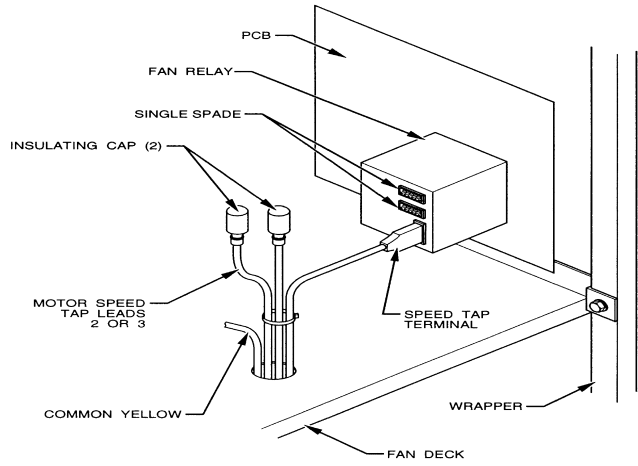

Figure 16 Conversion of Circuit Breaker

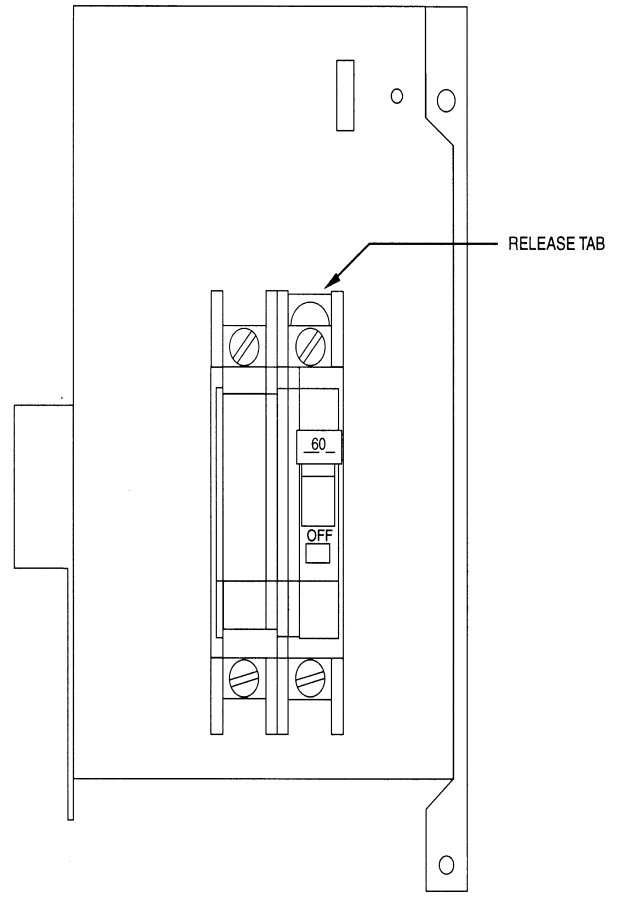

Figure 17 Heater Rating Label Location

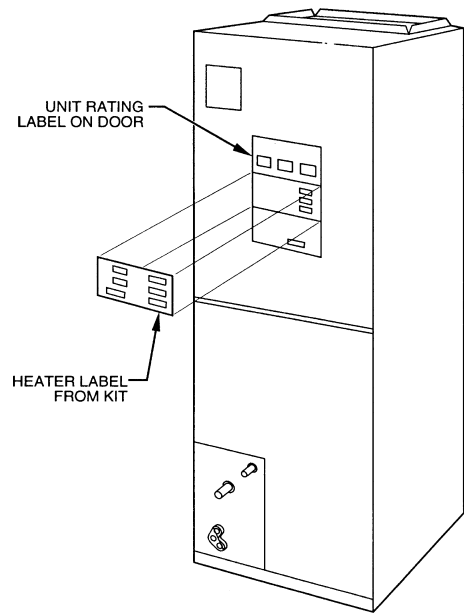

TABLE 3 - ELECTRIC HEATER ELECTRICAL DATA

Heater Model	Heater kW		Phase	Internal Circuit Protection	Heater Amps 208/230V			Minimum Circuit Ampacity (MCA) ☆			Max Fuse/Ckt Bkr Amps (Max Overcurrent Protection)		
	230V	208V			Single Circuit	Dual Circuit		Single Circuit	Dual Circuit		Single Circuit	Dual Circuit	
						L1, L2	L3, L4		L1, L2	L3, L4		L1, L2	L3, L4
EHK05AKN*	5	3.8	1	None	18.1/20.0	-	-	26.0/28.4	-	-	30/30	-	-
EHK05AKN**	5	3.8	1	None	18.1/20.0	-	-	31.2/33.5	-	-	35/35	-	-
EHK05AKB*	5	3.8	1	Ckt Bkr	18.1/20.0	-	-	26.0/28.4	-	-	30/30	-	-
EHK05AKB**	5	3.8	1	Ckt Bkr	18.1/20.0	-	-	31.2/33.5	-	-	35/35	-	-
EHK07AKN	8	6.0	1	None	28.9/32.0	-	-	44.7/48.5	-	-	45/50	-	-
EHK07AKB	8	6.0	1	Ckt Bkr	28.9/32.0	-	-	44.7/48.5	-	-	45/50	-	-
EHK09AKCN†	9	6.8	1	None	32.8/36.0	-	-	49.5/53.5	-	-	50/60	-	-
EHK10AKN	10	7.5	3	None	18.8/20.8	-	-	32.0/34.5	-	-	35/35	-	-
EHK10AKN	10	7.5	1	None	36.2/40.0	-	-	53.8/58.5	-	-	60/60	-	-
EHK10AKB	10	7.5	1	Ckt Bkr	36.2/40.0	-	-	53.8/58.5	-	-	60/60	-	-
EHK15AKF	15	11.3	1	Fuse	54.2/59.9	36.2/40.0	18.1/20.0	76.3/83.4	53.8/58.5	22.7/25.0	80/90	60/60	25/25
EHK15AKB	15	11.3	1	Ckt Bkr	-	36.2/40.0	18.1/20.0	-	53.8/58.5	22.7/25.0	-	60/60	25/25
EHK15AHN	15	11.3	3	None	31.3/34.6	-	-	47.7/51.8	-	-	50/60	-	-
EHK18AHN	18	13.5	3	None	37.6/41.5	-	-	55.5/60.4	-	-	60/70	-	-
EHK20AKF	20	15.0	1	Fuse	72.3/79.9	36.2/40.0	36.2/40.0	98.9/108.4	53.8/58.5	45.3/50.0	100/110	60/60	50/50
EHK20AKB	20	15.0	1	Ckt Bkr	-	36.2/40.0	36.2/40.0	-	53.8/58.5	45.3/50.0	-	60/60	50/50
EHK25AHCF‡	24	18.0	3	Fuse	50.1/55.4	-	-	71.2/77.8	-	-	80/80	-	-
EHK30AHCF‡	30	22.5	3	Fuse	86.7/95.5	-	-	116.9/127.9	-	-	125/150	-	-
EHK30AHCF‡	30	22.5	1	Fuse	62.6/69.2	-	-	86.8/95.0	-	-	90/100	-	-
EHK30AHCF‡	30	22.5	1	Fuse	109/120	-	-	144.8/158.5	-	-	150/175	-	-

TABLE 4 - FIELD MULTIPOINT WIRING OR 24 AND 30 KW SINGLE PHASE

Heater Model	Heater kW		P H A S E	Heater Amps 208/230V			Minimum Circuit Ampacity 208/230V ☆			Minimum Wire Size (AWG) 208/230V †			Min Gnd Wire Size 208/230V	Max Fuse/Ckt Bkr Amps 208/230V			Max Wire Length 208/230V (FT) ‡		
	230V	208V		L1, L2	L3, L4	L5, L6	L1, L2	L3, L4	L5, L6	L1, L2	L3, L4	L5, L6		L1, L2	L3, L4	L5, L6	L1, L2	L3, L4	L5, L6
EHK25AHCF‡	24	18.0	1	28.9/32.0	28.9/32.0	28.9/32.0	44.7/48.5	36.2/40.0	36.2/40.0	8/8	8/8	8/8	10/10	45/50	40/40	40/40	59/60	73/73	73/73
EHK30AHCF‡	30	22.5	1	36.2/40.0	36.2/40.0	36.2/40.0	53.8/58.5	45.3/50.0	45.3/50.0	8/8	8/8	8/8	10/10	60/60	50/50	50/50	78/80	59/59	59/59

Notes:

* When used with Fan Coil model sizes 2400, 3600

** When used with Fan Coil model sizes 4200, 4800, 6000

☆ Includes blower motor amps of largest Fan Coil used with heater

† Supplied as single phase, field convertible to 3 phase

‡ Supplied as 3 phase, field convertible to single phase, single or multiple supply circuits

‡‡ Length shown is as measured one way along wire path between unit and service panel for a voltage drop not to exceed 2%

WIRING DIAGRAM FOR HEAT ACCESSORIES

EHK05AKN/B, EHK07AKN/B, EHK10AKN/B

N = NON-FUSED, B = CIRCUIT BREAKER

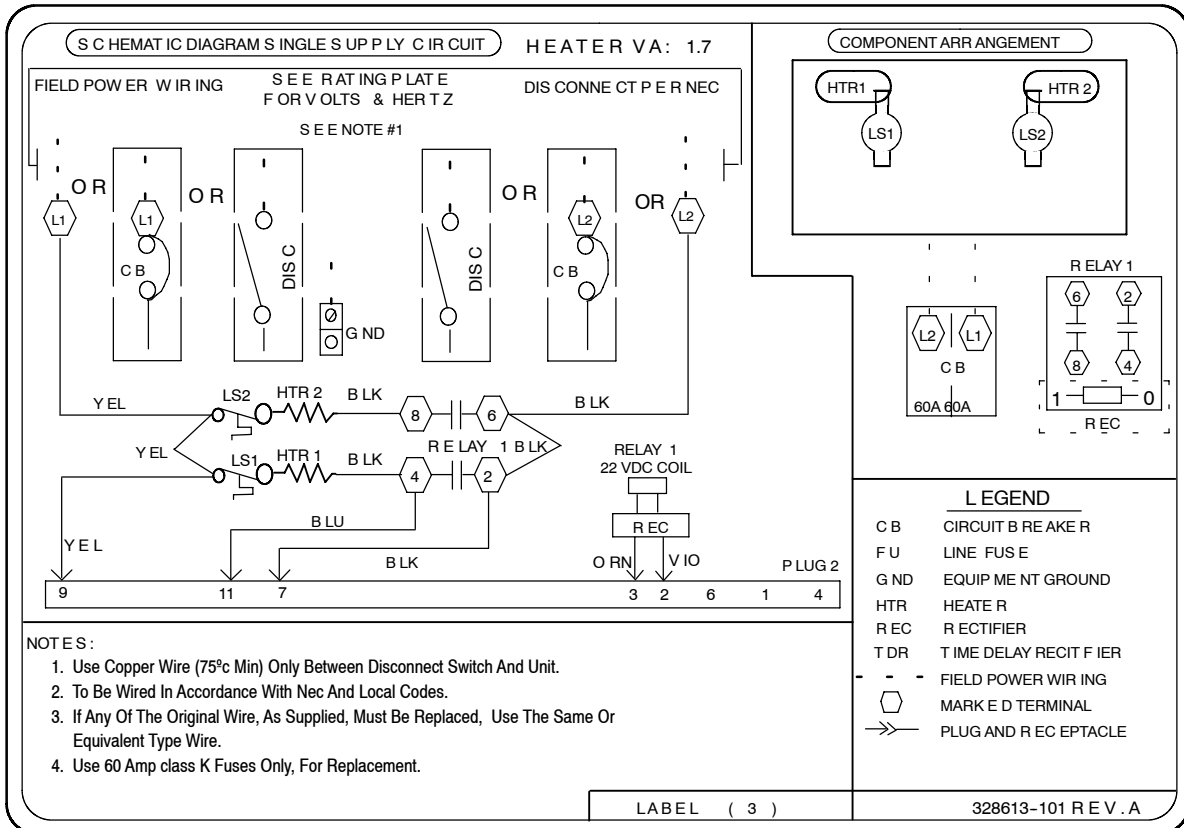

EHK15AKF/B

F = FUSED, B = CIRCUIT BREAKER

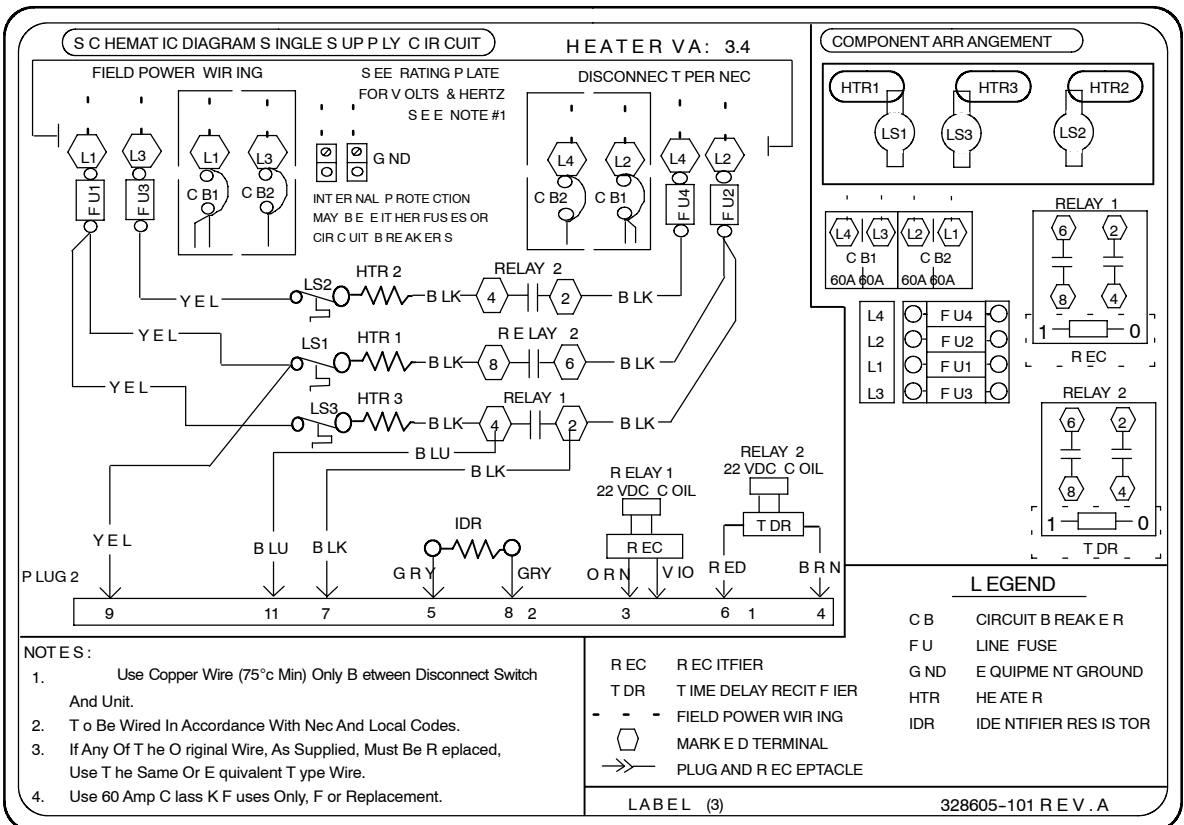

WIRING DIAGRAM FOR HEAT ACCESSORIES

EHK20AKF/B

F = FUSED, B = CIRCUIT BREAKER

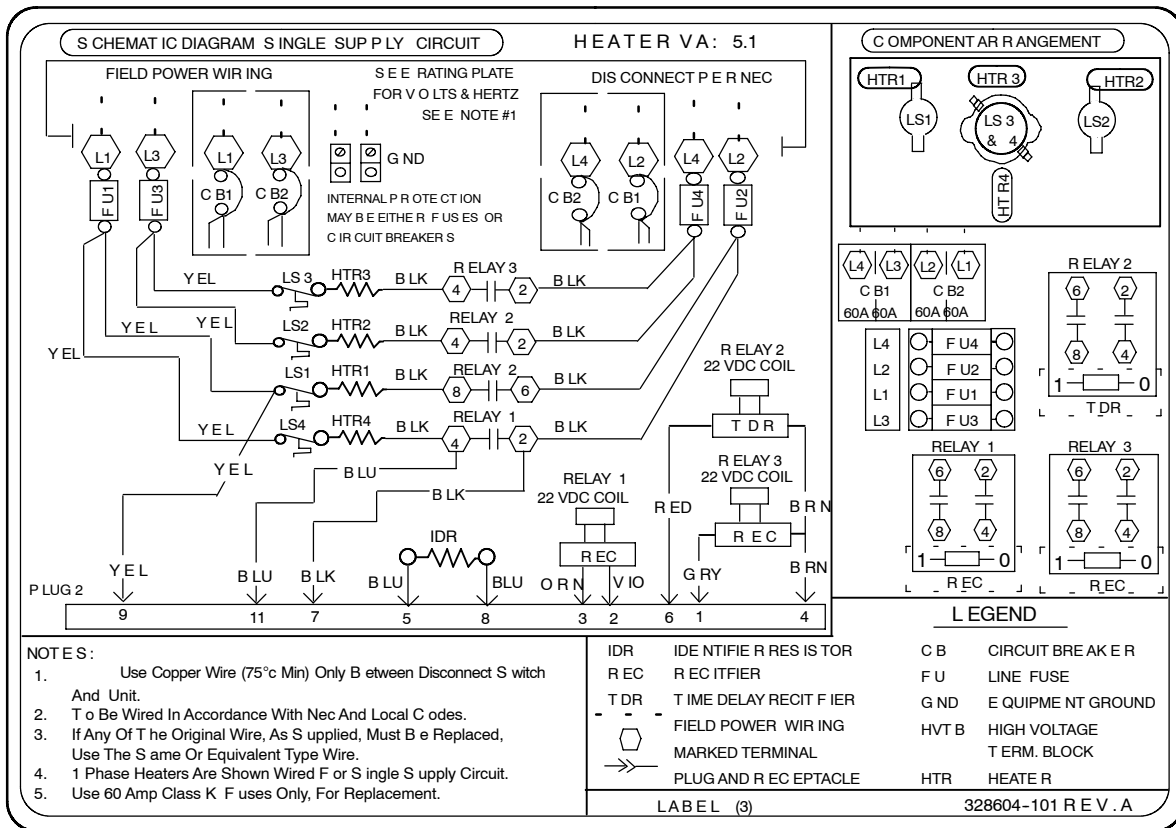

EHK15AHN

THREE PHASE, N = NON-FUSED

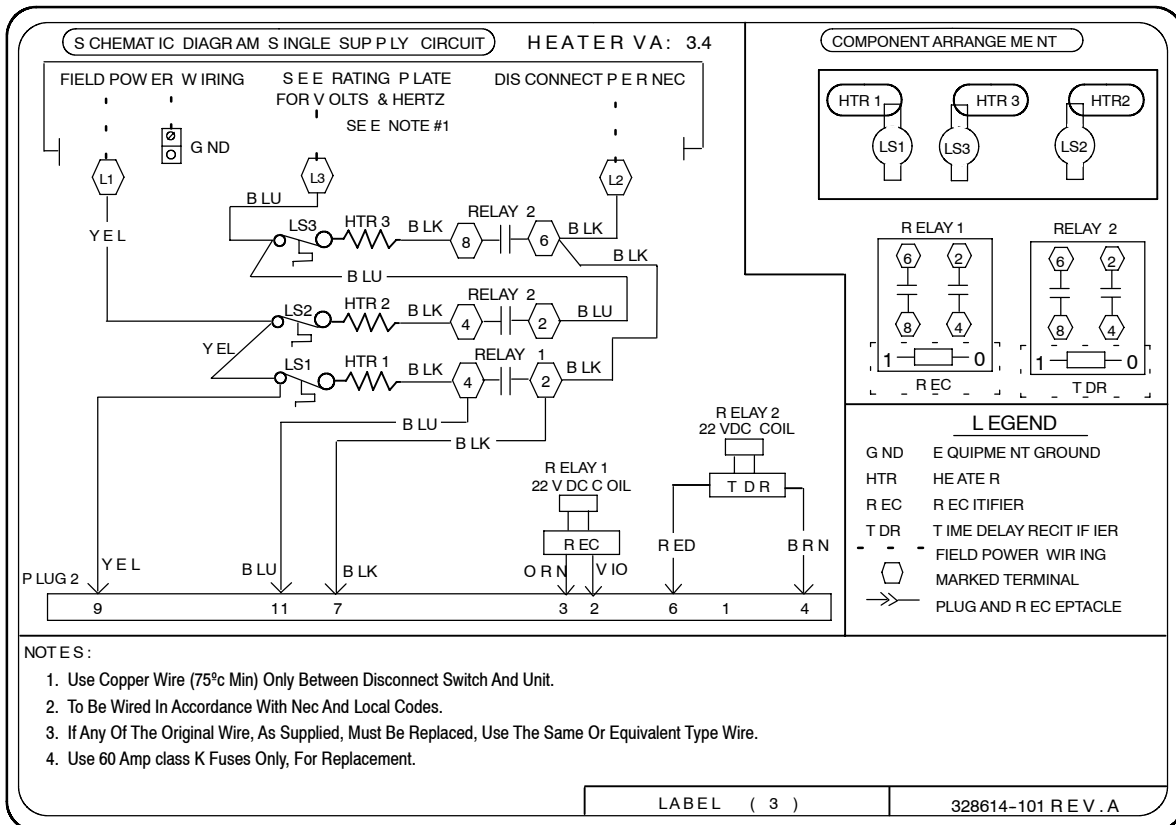

WIRING DIAGRAM FOR HEAT ACCESSORIES

EHK18AHN

THREE PHASE, N = NON-FUSED

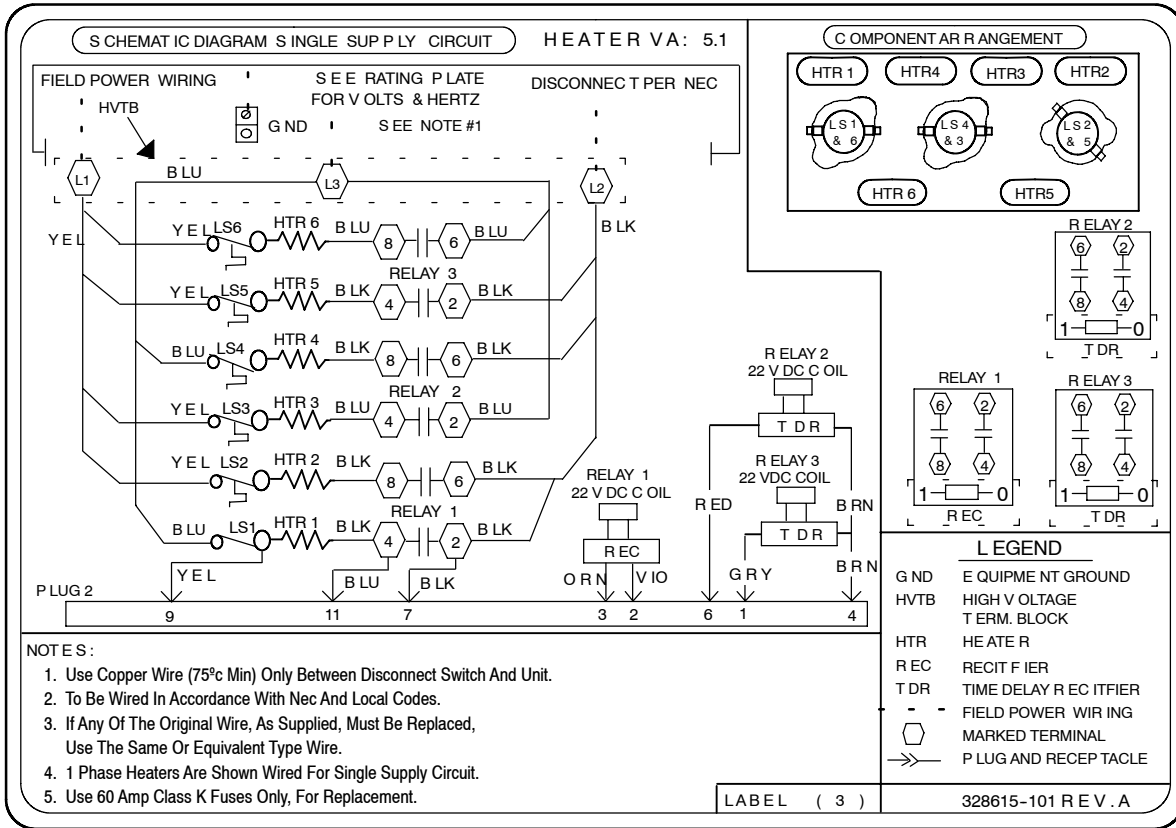

EHK09AKCN (Field Convertible to three phase.)

N = NON-FUSED

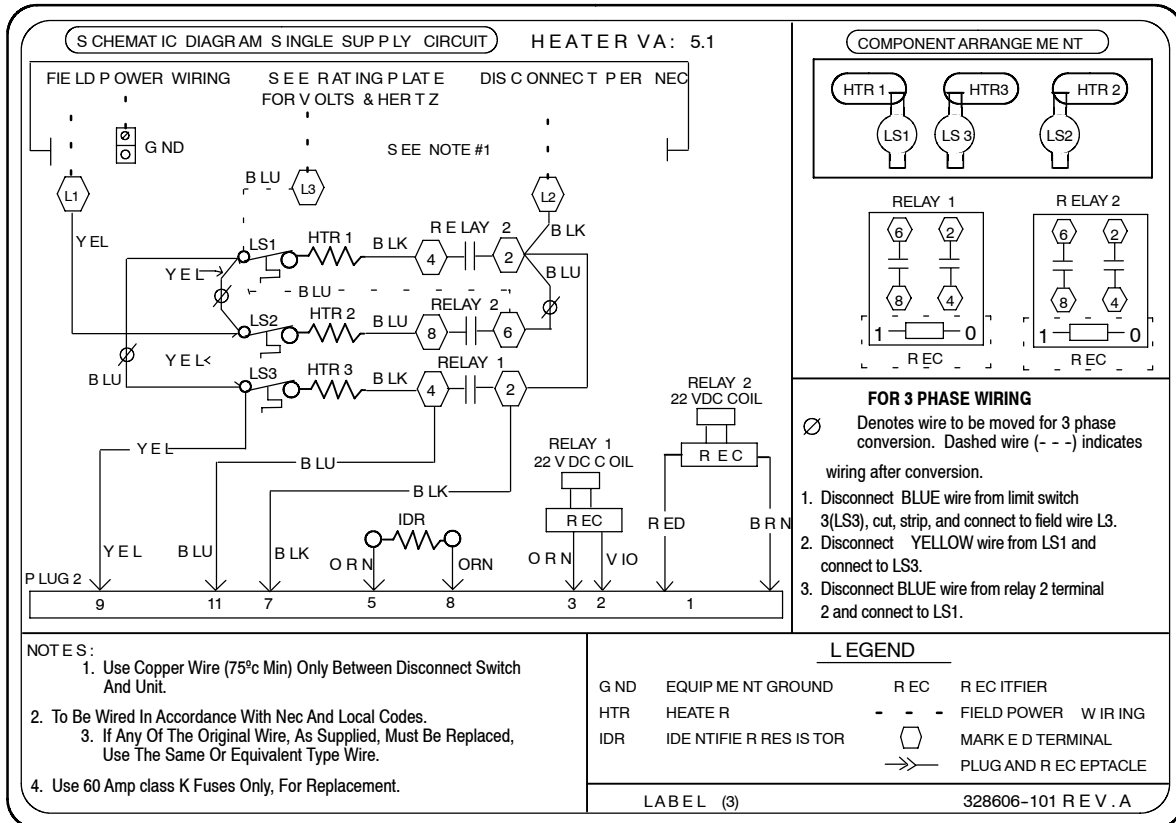

WIRING DIAGRAM FOR HEAT ACCESSORIES

EHK25AHCF, EHK30AHCF (Shipped three phase, see below.)

F = FUSED

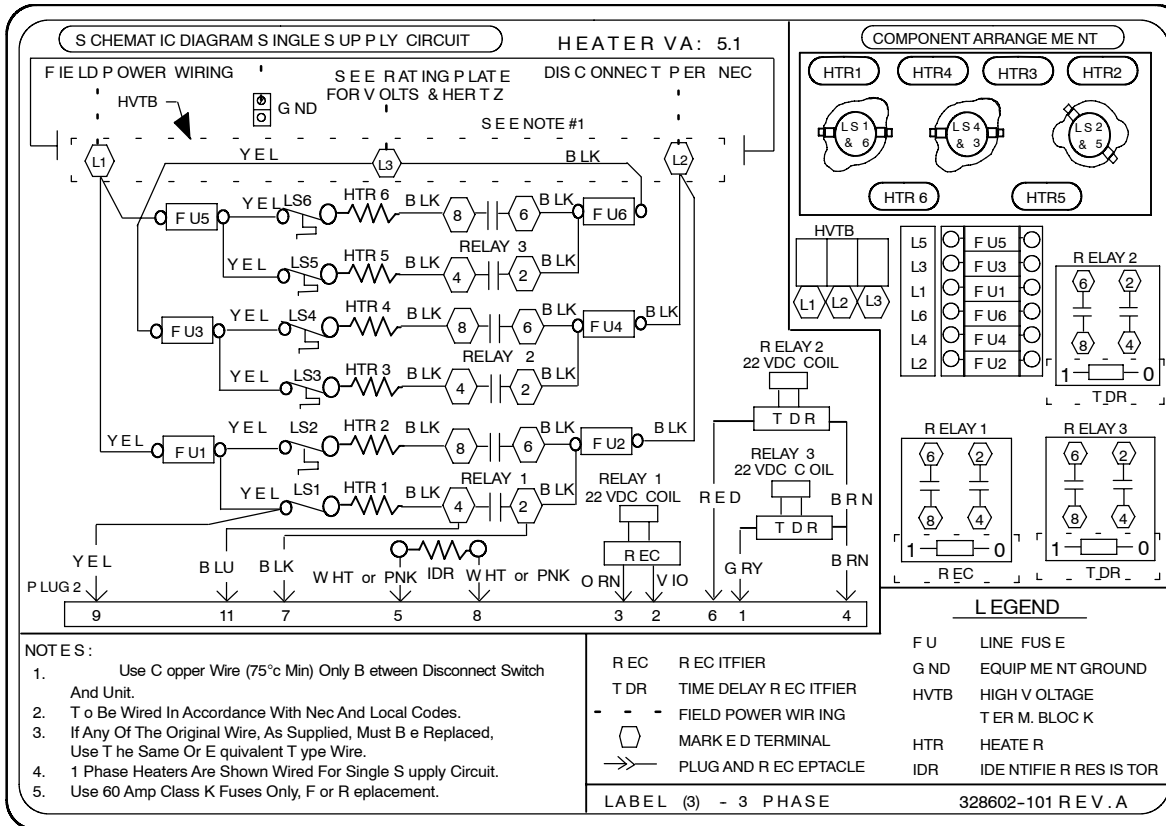

EHK25AHCF, EHK30AHCF (Field Converted to single phase, see below.)

F = FUSED

