

# Installation Instructions

## 90+ SINGLE STAGE GAS FURNACE DIRECT OR NON-DIRECT VENT FAN ASSISTED Category IV Furnace

### N9MP1/N9MP2/N9MPD/\*9MPD

**Upflow/Downflow/Horizontal**

\* Denotes Brands (C, H, T)

#### SAFETY REQUIREMENTS

Recognize safety information. This is the safety-alert symbol . When you see this symbol on the furnace and in instructions manuals be alert to the potential for personal injury.

Understand the signal words *DANGER*, *WARNING*, or *CAUTION*. These words are used with the safety-alert symbol. *DANGER* identifies the most serious hazards, those that **will** result in severe personal injury or death. *WARNING* signifies a hazard that **could** result in personal injury or death. *CAUTION* is used to identify unsafe practices that **could** result in minor personal injury or product and property damage. Note is used to highlight suggestions that will result in enhanced installation, reliability, or operation.

Installing and servicing heating equipment can be hazardous due to gas and electrical components. Only trained and qualified personnel should install, repair, or service heating equipment.

Untrained service personnel can perform basic maintenance functions such as cleaning and replacing air filters. All other operations must be performed by trained service personnel. When working on heating equipment, observe precautions in the literature, on tags, and on labels attached to or shipped with the unit and other safety precautions that may apply.

Follow all safety codes. In the United States, follow all safety codes including the current edition National Fuel Gas Code (NFPA) ANSI Z223.1-2006/NFPA No. 54-2006. In Canada, refer to the current edition of the National Standard of Canada Natural Gas and Propane Installation Code (NSCNGPIC) CSA B149.1-05. Wear safety glasses and work gloves. Have fire extinguisher available during start-up and adjustment procedures and service calls.

These instructions cover minimum requirements and conform to existing national standards and safety codes. In some instances, these instructions exceed certain local codes and ordinances, especially those that may not have kept up with changing residential construction practices. We require these instructions as a minimum for a safe installation.



**International Comfort Products, LLC**  
Lewisburg, TN 37091 U.S.A.

#### Table of Contents

1. Safe Installation Requirements .....	4	7. Electrical Wiring .....	38
2. Installation .....	5	8. Ductwork and Filter .....	39
3. Combustion & Ventilation Air .....	9	9. Checks and Adjustments .....	42
4. Vent & Combustion Air Piping .....	13	10. Furnace Maintenance .....	44
5. Concentric Vent Termination .....	30	11. Sequence of Operation & Diagnostics .....	45
6. Gas Supply and Piping .....	33	Technical Support .....	47

**INSTALLER:** Affix these instructions on or adjacent to the furnace.

**CONSUMER:** Retain these instructions for future reference.



#### **WARNING**

**ELECTRIC SHOCK HAZARD.**  
Failure to follow this warning could result in personal injury, and/or death.  
**Turn Off All Power Before Servicing.**

#### **WARNING**

**CARBON MONOXIDE POISONING AND FIRE HAZARD.**  
Failure to follow safety warnings could result in personal injury, death, and/or property damage.  
**This furnace is not designed for use in mobile homes, trailers or recreational vehicles.**

Portions of the text and tables are reprinted from NFPA 54 / ANSI Z223.1-2006©, with permission of National Fire Protection Association, Quincy, MA 02269 and American Gas Association, Washington, DC 20001. This reprinted material is not the complete and official position of the NFPA or ANSI, on the referenced subject, which is represented only by the standard in its entirety.

# Required Notice for Massachusetts Installations

## Important

The Commonwealth of Massachusetts requires compliance with regulation 248 CMR as follows:

### 5.08: Modifications to NFPA-54, Chapter 10

2) Revise 10.8.3 by adding the following additional requirements:

- (a) For all side wall horizontally vented gas fueled equipment installed in every dwelling, building or structure used in whole or in part for residential purposes, including those owned or operated by the Commonwealth and where the side wall exhaust vent termination is less than seven (7) feet above finished grade in the area of the venting, including but not limited to decks and porches, the following requirements shall be satisfied:
1. **INSTALLATION OF CARBON MONOXIDE DETECTORS.** At the time of installation of the side wall horizontal vented gas fueled equipment, the installing plumber or gasfitter shall observe that a hard wired carbon monoxide detector with an alarm and battery back-up is installed on the floor level where the gas equipment is to be installed. In addition, the installing plumber or gasfitter shall observe that a battery operated or hard wired carbon monoxide detector with an alarm is installed on each additional level of the dwelling, building or structure served by the side wall horizontal vented gas fueled equipment. It shall be the responsibility of the property owner to secure the services of qualified license professionals for the installation of hard wired carbon monoxide detectors.
    - a. In the event that the side wall horizontally vented gas fueled equipment is installed in a crawl space or an attic, the hard wired carbon monoxide detector with alarm and battery back-up may be installed on the next adjacent floor level.
    - b. In the event that the requirements of this subdivision can not be met at the time of completion of installation, the owner shall have a period of thirty (30) days to comply with the above requirement; provided, however, that during said thirty (30) day period, a battery operated carbon monoxide detector with an alarm shall be installed.
  2. **APPROVED CARBON MONOXIDE DETECTORS.** Each carbon monoxide detector as required in accordance with the above provisions shall comply with NFPA 720 and be ANSI/UL 2034 listed and IAS certified.
  3. **SIGNAGE.** A metal or plastic identification plate shall be permanently mounted to the exterior of the building at a minimum height of eight (8) feet above grade directly in line with the exhaust vent terminal for the horizontally vented gas fueled heating appliance or equipment. The sign shall read, in print size no less than one-half (1/2) inch in size, "**GAS VENT DIRECTLY BELOW. KEEP CLEAR OF ALL OBSTRUCTIONS**".
  4. **INSPECTION.** The state of local gas inspector of the side wall horizontally vented gas fueled equipment shall not approve the installation unless, upon inspection, the inspector observes carbon monoxide detectors and signage installed in accordance with the provisions of 248 CMR 5.08(2)(a) 1 through 4.
- (b) **EXEMPTIONS:** The following equipment is exempt from 248 CMR 5.08(2)(a) 1 through 4:
1. The equipment listed in Chapter 10 entitled "Equipment Not Required To Be Vented" in the most current edition of NFPA 54 as adopted by the Board; and
  2. Product Approved side wall horizontally vented gas fueled equipment installed in a room or structure separate from the dwelling, building or structure used in whole or in part for residential purposes.
- (c) **MANUFACTURER REQUIREMENTS - GAS EQUIPMENT VENTING SYSTEM PROVIDED.** When the manufacturer of Product Approved side wall horizontally vented gas equipment provides a venting system design or venting system components with the equipment, the instructions provided by the manufacturer for installation of the equipment and the venting system shall include:
1. Detailed instructions for the installation of the venting system design or the venting system components; and
  2. A complete parts list for the venting system design or venting system.
- (d) **MANUFACTURER REQUIREMENTS - GAS EQUIPMENT VENTING SYSTEM NOT PROVIDED.** When the manufacturer of a Product Approved side wall horizontally vented gas fueled equipment does not provide the parts for venting the flue gases, but identifies "special venting systems", the following requirements shall be satisfied by the manufacturer:
1. The referenced "special venting system" instructions shall be included with the appliance or equipment installation instructions; and
  2. The "special venting systems" shall be Product Approved by the Board, and the instructions for that system shall include a parts list and detailed installation instructions.
- (e) A copy of all installation instructions for all Product Approved side wall horizontally vented gas fueled equipment, all venting instructions, all parts lists for venting instructions, and/or all venting design instructions shall remain with the appliance or equipment at the completion of the installation.

For questions regarding these requirements, please contact the Commonwealth of Massachusetts Board of State Examiners of Plumbers and Gas Fitters, 239 Causeway Street, Boston, MA 02114. 617-727-9952

# START-UP CHECK SHEET

## For 90+ Furnace

(This sheet is optional. Keep this page for future reference.)

Date of Start-Up: \_\_\_\_\_

Dealer Name: \_\_\_\_\_

Address: \_\_\_\_\_

City, State(Province), Zip or Postal Code: \_\_\_\_\_

Phone: \_\_\_\_\_

Owner Name: \_\_\_\_\_

Address: \_\_\_\_\_

City, State(Province), Zip or Postal Code: \_\_\_\_\_

Model Number: \_\_\_\_\_

Serial Number: \_\_\_\_\_

### Setup Checks

Check the box when task is complete

All Electrical Connections Tight?

Have hoses been relocated for furnace application  
(upflow/horizontal)?

Condensate Drain Connected?

Condensate Drain Trapped?

Manual Gas Shut-Off Upstream of Furnace/Drip-Leg?

Gas Valve turned ON?

Type of Gas: Natural:  Propane:

Filter Type and Size: \_\_\_\_\_

Calculated Firing Rate:(See *Checks and Adjustments* Section). \_\_\_\_\_

### Heating Check

Measured Line Pressure when Firing Unit: \_\_\_\_\_

Measured Manifold Gas Pressure: \_\_\_\_\_

Temperature of Supply Air: (°)\_\_\_\_\_

Temperature of Return Air: (°)\_\_\_\_\_

Temperature Rise (supply-return temperature): (°)\_\_\_\_\_

In Rise (see furnace rating plate)? (°)\_\_\_\_\_

Static Pressure (Ducts): Supply Air \_\_\_\_\_ Return \_\_\_\_\_

Which blower speed tap is used? (Heating) \_\_\_\_\_

Optional Check: CO ? \_\_\_\_\_ CO2 ? \_\_\_\_\_

### Cooling Check

Temperature of Supply Air: (°)\_\_\_\_\_

Temperature of Return Air: (°)\_\_\_\_\_

Temperature Difference: (°)\_\_\_\_\_

Static Pressure (Ducts) cooling: Supply Air\_\_ Return \_\_

Blower Speed Tap used for cooling: \_\_\_\_\_

Dealer Comments: \_\_\_\_\_

\_\_\_\_\_

\_\_\_\_\_

\_\_\_\_\_

\_\_\_\_\_

# 1. Safe Installation Requirements



## WARNING

**FIRE, EXPLOSION, AND ASPHYXIATION HAZARD.** Improper adjustment, alteration, service, maintenance or installation could cause personal injury, death and/or property damage.

**Installation or repairs made by unqualified persons could result in hazards to you and others. Installation MUST conform with local codes or, in the absence of local codes, with codes of all governmental authorities having jurisdiction.**

**The information contained in this manual is intended for use by a qualified service agency that is experienced in such work, is familiar with all precautions and safety procedures required in such work, and is equipped with the proper tools and test instruments.**

**NOTE:** This furnace is design-certified by the CSA International (formerly AGA and CGA) for installation in the United States and Canada. Refer to the appropriate codes, along with this manual, for proper installation.

- Use only the Type of gas approved for this furnace (see **Rating Plate** on unit). Overfiring will result in failure of heat exchanger and cause dangerous operation. (Furnaces can be converted to Propane gas with approved kit.)
  - Install this furnace only in a location and position as specified in "*Installation*" of these instructions.
  - Provide adequate combustion and ventilation air to the furnace as specified in "*Combustion and Ventilation Air*" of these instructions.
  - Combustion products must be discharged outdoors. Connect this furnace to an approved vent system only, as specified in "*Vent and Combustion Air Piping*" of these instructions.
  - Never test for gas leaks with an open flame. Use a commercially available soap solution made specifically for the detection of leaks to check all connections, as specified in "*Gas Supply and Piping, Final Check*" of these instructions.
  - Always install furnace to operate within the furnace's intended temperature-rise range with a duct system which has an external static pressure within the allowable range, as specified in "*Technical Support Manual*" of these instructions. See furnace rating plate.
  - When a furnace is installed so that supply ducts carry air circulated by the furnace to areas outside the space containing the furnace, the return air shall also be handled by a duct(s) sealed to the furnace casing and terminating outside the space containing the furnace.
  - A gas-fired furnace for installation in a residential garage must be installed as specified in "*Installation*" of these instructions.
- This furnace is not to be used for temporary heating of buildings or structures under construction.
  - **This furnace is NOT approved for installation in mobile homes, trailers or recreation vehicles.**
  - Seal around supply and return air ducts.
  - Install correct filter type and size.
  - Unit **MUST** be installed so electrical components are protected from direct contact with water.

## Safety Rules

Your unit is built to provide many years of safe and dependable service providing it is properly installed and maintained. However, abuse and/or improper use can shorten the life of the unit and create hazards for you, the owner.

- A. The U.S. Consumer Product Safety Commission encourages installation of carbon monoxide alarms. There can be various sources of carbon monoxide in a building or dwelling. The sources could be gas-fired clothes dryers, gas cooking stoves, water heaters, furnaces, gas-fired fireplaces, wood fireplaces.

Carbon monoxide can cause serious bodily injury and/or death. Carbon monoxide or "CO" is a colorless and odorless gas produced when fuel is not burned completely or when the flame does not receive sufficient oxygen.

Therefore, to help alert people of potentially dangerous carbon monoxide levels, you should have a commercially available carbon monoxide alarm that is listed by a nationally recognized testing agency in accordance with Underwriters Laboratories Inc. Standard for Single and Multiple Station Carbon Monoxide Alarms, ANSI/UL 2034 or the CSA 6.19-01 Residential Carbon Alarming Devices installed and maintained in the building or dwelling concurrently with the gas-fired furnace installation (see Note below). The alarm should be installed as recommended by the alarm manufacturer's installation instructions.

- B. There can be numerous sources of fire or smoke in a building or dwelling. Fire or smoke can cause serious bodily injury, death, and/or property damage. Therefore, in order to alert people of potentially dangerous fire or smoke, you should have fire extinguisher and smoke alarms listed by Underwriters Laboratories installed and maintained in the building or dwelling (see Note below).

**Note:** The manufacturer of your furnace does not test any alarms and makes no representations regarding any brand or type of alarms.

- C. To ensure safe and efficient operation of your unit, you should do the following:

1. **Thoroughly read this manual and labels on the unit.** This will help you understand how your unit operates and the hazards involved with gas and electricity.
2. **Do not use this unit if any part has been under water.** Immediately call a qualified service technician to inspect the unit and to replace any part of the control system and any gas control which has been under water.
3. **Never obstruct the vent grilles, or any ducts that provide air to the unit.** Air must be provided for proper combustion and ventilation of flue gases.

## Frozen Water Pipe Hazard



### CAUTION

#### WATER DAMAGE TO PROPERTY HAZARD.

Failure to follow this caution may result in property damage.

Do not leave your home unattended for long periods during freezing weather without turning off water supply and draining water pipes or otherwise protecting against the risk of frozen pipes and resultant damage.

Your furnace is designed solely to provide a safe and comfortable living environment. The furnace is NOT designed to ensure that water pipes will not freeze. It is equipped with several safety devices that are designed to turn the furnace off and prevent it from restarting in the event of various potentially unsafe conditions.

If your furnace remains off for an extended time, the pipes in your home could freeze and burst, resulting in serious water damage.

If the structure will be unattended during cold weather you should take these precautions.

1. Turn off the water supply to the structure and drain the water lines if possible and add an antifreeze for potable water to drain traps and toilet tanks. Open faucets in appropriate areas.

-or-

2. Have someone check the structure frequently during cold weather to make sure it is warm enough to prevent pipes from freezing. Instruct them on a service agency to call to provide service, if required.

-or-

3. Install a reliable remote sensing device that will notify somebody of freezing conditions within the home.

## Winter Shutdown

If you go away during the winter months and do not leave the heat on in your home, the plastic transition box and the condensate trap on the furnace must be protected from freeze damage. (See Figure 11 through Figure 20)

1. Disconnect the  $\frac{5}{8}$ " OD rubber hose from the vent drain fitting that is located downstream of the combustion blower. Insert a funnel into the hose and pour four(4) ounces of sanitary type (RV) antifreeze into the condensate trap. Reconnect the  $\frac{5}{8}$ " OD rubber hose to the stub on the vent drain fitting. Secure with the hose clamp.
2. Disconnect the  $\frac{3}{4}$ " OD rubber hose from the condensate trap. Insert a funnel into the hose and pour four(4) ounces of sanitary type (RV) antifreeze into the plastic Transition box. Squeeze the hose together near the end and quickly reconnect the  $\frac{3}{4}$ " OD rubber hose to the stub on the condensate trap. Secure with the hose clamp.

When you return home, your furnace will be ready to start, as it is not necessary to drain the antifreeze from the furnace.

## 2. Installation



### WARNING

#### CARBON MONOXIDE POISONING HAZARD.

Failure to follow this warning could result in personal injury or death.

This furnace can NOT be common vented or connected to any type B, BW or L vent or vent connector, nor to any portion of a factory-built or masonry chimney. If this furnace is replacing a previously common-vented furnace, it may be necessary to resize the existing vent and chimney to prevent oversizing problems for the other remaining appliance(s). See *Venting and Combustion Air Check* in *Gas Vent Installation* section. This furnace MUST be vented to the outside.

## Location and Clearances

1. Refer to Figure 1 or Figure 2 for typical installation and basic connecting parts required. Refer to Figure 5 for typical horizontal direct vent installation and basic connecting parts required. Supply and return air plenums and duct are also required.
2. If furnace is a replacement, it is usually best to install the furnace where the old one was. Choose the location or evaluate the existing location based upon the minimum clearance and furnace dimensions (Figure 3).

Figure 1

Typical Upflow Installation

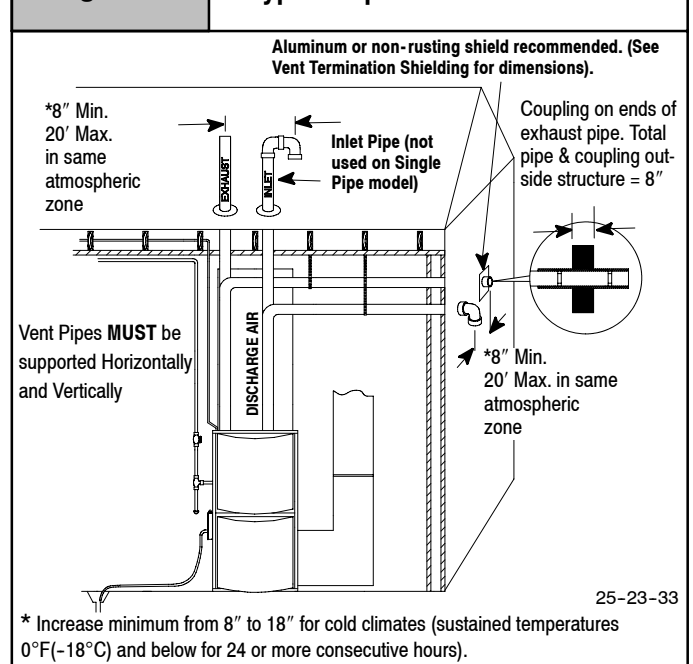

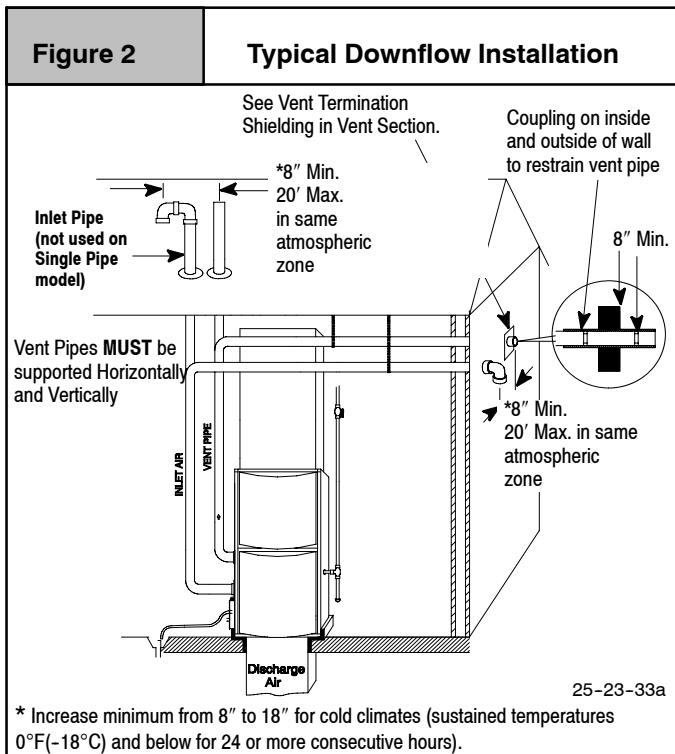

**⚠ WARNING**

**CARBON MONOXIDE POISONING HAZARD.**  
 Failure to follow this warning could result in personal injury or death.  
 Do NOT operate furnace in a corrosive atmosphere containing chlorine, fluorine or any other damaging chemicals, which could shorten furnace life.  
 Refer to *Combustion & Ventilation Air* section, *Contaminated Combustion Air* for combustion air evaluation and remedy.

**⚠ CAUTION**

**FROZEN AND BURST WATER PIPE HAZARD.**  
 Failure to follow this caution may result in property damage.  
 Special precautions MUST be made if installing furnace in an area which may drop below freezing. This can cause improper operation or damage to equipment. If furnace environment has the potential of freezing, the drain trap and drainline must be protected. The use of electric heat tape or RV antifreeze is recommended for these installations. (See "*Condensate Trap Freeze Protection Section*")

Do NOT operate furnace in a corrosive atmosphere containing chlorine, fluorine or any other damaging chemicals. Refer to *Combustion & Ventilation Air* section, *Contaminated Combustion Air*.

## Installation Requirements

1. Install furnace level.
2. This furnace is **NOT** to be used for temporary heat of buildings or structures under construction.

3. Install the vent pipes as short as practical. (See **Gas Vent Installation** section).
4. Do **NOT** install furnace directly on carpeting, tile or other combustible material other than wood flooring.
5. Maintain clearance for fire safety and servicing. A front clearance of 24" required and 30" recommended for access to the burner, controls and filter. See clearance requirements in **Figure 3**.
6. Use a raised base if the floor is damp or wet at times.
7. Residential garage installations require:
  - Burners and ignition sources installed at least 18" above the floor.
  - Furnace must be located or physically protected from possible damage by a vehicle.
8. If the furnace is to be suspended from the floor joists in a basement or a crawl space or the rafters in an attic, it is necessary to use steel pipe straps or an angle iron frame to attach the furnace. These straps should be attached to the furnace with sheet metal screws and to the rafters or joists with bolts. The preferred method is to use an angle iron frame bolted to the rafters or joists.
9. Local codes may require a drain pan under the entire furnace and condensate trap when the furnace is installed in attic application.

This furnace may be used for construction heat provided that all the following conditions are met:

- The furnace is permanently installed with all electrical wiring, piping, venting and ducting installed according to these installation instructions. A return air duct is provided, sealed to the furnace casing, and terminated outside the space containing the furnace. This prevents a negative pressure condition as created by the circulating air blower, causing a flame rollout and/or drawing combustion products into the structure.
- The furnace is controlled by a thermostat. It may not be "hot wired" to provide heat continuously to the structure without thermostatic control.
- Clean outside air is provided for combustion. This is to minimize the corrosive effects of adhesives, sealers and other construction materials. It also prevents the entrainment of drywall dust into combustion air, which can cause fouling and plugging of furnace components.
- The temperature of the return air to the furnace is maintained between 55° F (13° C) and 80° F (27° C), with no evening setback or shutdown. The use of the furnace while the structure is under construction is deemed to be intermittent operation per our installation instructions.
- The air temperature rise is within the rated rise range on the furnace rating plate, and the firing rate has been set to the rating plate value.
- The filters used to clean the circulating air during the construction process must be either changed or thoroughly cleaned prior to occupancy.
- The furnace, ductwork and filters are cleaned as necessary to remove drywall dust and construction debris from all HVAC system components after construction is completed.
- After construction is complete, verify furnace operating conditions including ignition, input rate, temperature rise and venting according to these instructions.

**Figure 3**

**Dimensions & Clearances**

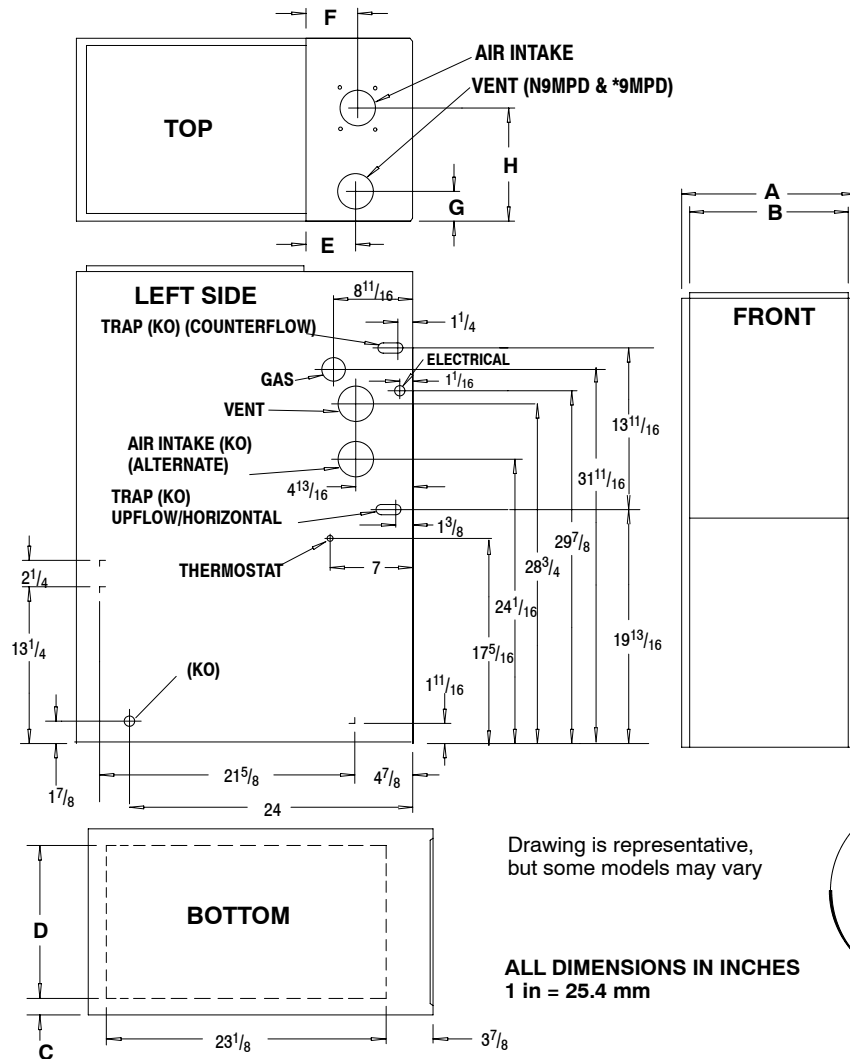

Drawing is representative, but some models may vary

**ALL DIMENSIONS IN INCHES**  
1 in = 25.4 mm

MINIMUM CLEARANCES TO COMBUSTIBLE MATERIALS FOR ALL UNITS	
REAR	0
FRONT (combustion air openings in furnace and in structure)	3"
Required For Service	*24"
ALL SIDES OF SUPPLY PLENUM	1"
SIDES	0
VENT	0
TOP OF FURNACE	1"

\*30" clearance recommended for furnace removal.

Horizontal position: Line contact is permissible only between lines formed by intersections of top and two sides of furnace jacket, and building joists, studs or framing.

**NOTE:** Evaporator "A" coil drain pan dimensions may vary from furnace duct opening size. Always consult evaporator specifications for duct size requirements.

Furnace is designed for bottom return or side return.

Return air through back of furnace is NOT allowed.

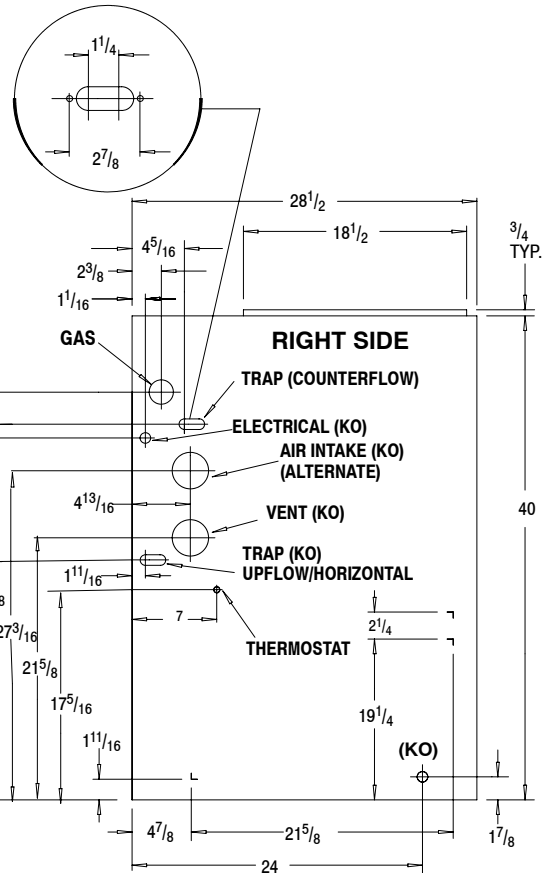

Unit Capacity	Cabinet		Bottom		Top			
	A	B	C	D	E	F	G	H
N9MP1040/050B <sup>^^</sup>	15 <sup>1</sup> / <sub>2</sub>	14	1 <sup>3</sup> / <sub>8</sub>	12 <sup>5</sup> / <sub>8</sub>	--	--	--	--
N9MP1060/075B <sup>^^</sup>	15 <sup>1</sup> / <sub>2</sub>	14	1 <sup>3</sup> / <sub>8</sub>	12 <sup>5</sup> / <sub>8</sub>	--	--	--	--
N9MP1080/100F <sup>^^</sup>	19 <sup>1</sup> / <sub>8</sub>	17 <sup>5</sup> / <sub>8</sub>	2 <sup>1</sup> / <sub>8</sub>	14 <sup>3</sup> / <sub>4</sub>	--	--	--	--
N9MP1100/125J <sup>^^</sup>	22 <sup>3</sup> / <sub>4</sub>	21 <sup>1</sup> / <sub>4</sub>	1 <sup>15</sup> / <sub>16</sub>	18 <sup>3</sup> / <sub>4</sub>	--	--	--	--
N9MP2050/075B <sup>^^</sup>	15 <sup>1</sup> / <sub>2</sub>	14	1 <sup>3</sup> / <sub>8</sub>	12 <sup>5</sup> / <sub>8</sub>	--	4 <sup>1</sup> / <sub>2</sub>	--	7 <sup>3</sup> / <sub>4</sub>
N9MP2080/100F <sup>^^</sup>	19 <sup>1</sup> / <sub>8</sub>	17 <sup>5</sup> / <sub>8</sub>	2 <sup>1</sup> / <sub>8</sub>	14 <sup>3</sup> / <sub>4</sub>	--	4 <sup>1</sup> / <sub>2</sub>	--	9 <sup>1</sup> / <sub>2</sub>
N9MP2100/125J <sup>^^</sup>	22 <sup>3</sup> / <sub>4</sub>	21 <sup>1</sup> / <sub>4</sub>	1 <sup>15</sup> / <sub>16</sub>	18 <sup>3</sup> / <sub>4</sub>	--	4 <sup>1</sup> / <sub>2</sub>	--	11 <sup>3</sup> / <sub>8</sub>
N9MPD040/050F <sup>^^</sup>	19 <sup>1</sup> / <sub>8</sub>	17 <sup>5</sup> / <sub>8</sub>	2 <sup>1</sup> / <sub>8</sub>	14 <sup>3</sup> / <sub>4</sub>	4 <sup>3</sup> / <sub>8</sub>	4 <sup>1</sup> / <sub>2</sub>	2 <sup>1</sup> / <sub>2</sub>	9 <sup>1</sup> / <sub>2</sub>
N9MPD060/075F <sup>^^</sup>	19 <sup>1</sup> / <sub>8</sub>	17 <sup>5</sup> / <sub>8</sub>	2 <sup>1</sup> / <sub>8</sub>	14 <sup>3</sup> / <sub>4</sub>	4 <sup>3</sup> / <sub>8</sub>	4 <sup>1</sup> / <sub>2</sub>	2 <sup>1</sup> / <sub>2</sub>	9 <sup>1</sup> / <sub>2</sub>
N9MPD080/100J <sup>^^</sup>	22 <sup>3</sup> / <sub>4</sub>	21 <sup>1</sup> / <sub>4</sub>	1 <sup>15</sup> / <sub>16</sub>	18 <sup>3</sup> / <sub>4</sub>	4 <sup>3</sup> / <sub>8</sub>	4 <sup>1</sup> / <sub>2</sub>	2 <sup>5</sup> / <sub>8</sub>	11 <sup>3</sup> / <sub>8</sub>
N9MPD125L <sup>^^</sup>	24 <sup>1</sup> / <sub>2</sub>	23	1 <sup>1</sup> / <sub>16</sub>	23	4 <sup>3</sup> / <sub>8</sub>	4 <sup>1</sup> / <sub>2</sub>	2 <sup>1</sup> / <sub>4</sub>	12 <sup>1</sup> / <sub>4</sub>
*9MPD050/075F <sup>^^</sup>	19 <sup>1</sup> / <sub>8</sub>	17 <sup>5</sup> / <sub>8</sub>	2 <sup>1</sup> / <sub>8</sub>	14 <sup>3</sup> / <sub>4</sub>	4 <sup>3</sup> / <sub>8</sub>	4 <sup>1</sup> / <sub>2</sub>	2 <sup>1</sup> / <sub>2</sub>	9 <sup>1</sup> / <sub>2</sub>
*9MPD080/100J <sup>^^</sup>	22 <sup>3</sup> / <sub>4</sub>	21 <sup>1</sup> / <sub>4</sub>	1 <sup>15</sup> / <sub>16</sub>	18 <sup>3</sup> / <sub>4</sub>	4 <sup>3</sup> / <sub>8</sub>	4 <sup>1</sup> / <sub>2</sub>	2 <sup>5</sup> / <sub>8</sub>	11 <sup>3</sup> / <sub>8</sub>
*9MPD125L <sup>^^</sup>	24 <sup>1</sup> / <sub>2</sub>	23	1 <sup>1</sup> / <sub>16</sub>	23	4 <sup>3</sup> / <sub>8</sub>	4 <sup>1</sup> / <sub>2</sub>	2 <sup>1</sup> / <sub>4</sub>	12 <sup>1</sup> / <sub>4</sub>

\* Denotes Brand  
^^ Cooling Air Flow

KO = KnockOut

25-23-36b

## Knock Outs



# CAUTION

### CUT HAZARD.

Failure to follow this caution may result in personal injury.

Sheet metal parts may have sharp edges or burrs. Use care and wear appropriate clothing, safety glasses and gloves when handling parts and servicing furnaces.

Use a hammer and screwdriver to strike a sharp blow (See **Figure 4**) directly to the knockout tie points or use a hammer in the upper left corner of the desired knockout. Remove any burrs and sharp edges.

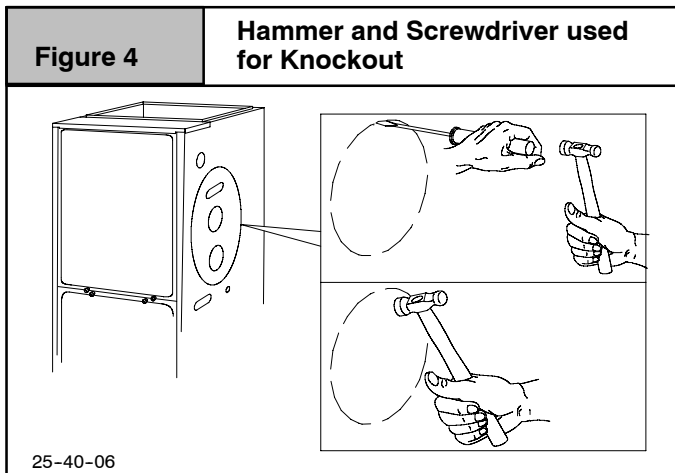

NOTE: If a knockout does not come out after two sharp blows, pull and snip as needed to remove the knockout.

## Installation Positions

This furnace can be installed in an upflow, horizontal (either left or right) or downflow airflow position. DO NOT install this furnace on its back. For the upflow position, the return air ductwork can be attached to either the left or right side panel and/or the bottom. For horizontal and downflow positions, the return air ductwork must be attached to the bottom. The return air ductwork must **never** be attached to the back of the furnace.

## Furnace Installation Considerations

The installation of the furnace for a given application will dictate the position of the furnace, the airflow, ductwork connections, vent and combustion air piping. Consideration must be given to the following:

## Condensate Trap and Drain Lines

The supplied condensate trap must be attached to the furnace side panel on either the left or right side. For horizontal installations, the drain trap is vertically attached to the side panel below the furnace. A minimum clearance of 6" below the furnace is required for the condensate trap. Downward slope of the condensate drain line from the condensate trap to the drain location must be provided. Adequate freeze protection of the drain trap and the drain line must be provided. See "Condensate Drain Trap" section for further details.

## Leveling

Proper leveling of the furnace must be provided to insure proper drainage of the condensate from the furnace. The furnace must be level to within 1/4" from front to back and from side to side for upflow

and downflow installations or top to bottom for horizontal installations.

## Vent and Combustion Air Connections

For venting information literature, call 931.270.4100 with the complete model and serial number of the furnace.

NOTE: Furnaces installed in Canada must use vent systems that are certified to the standard for Type BH Gas Venting Systems, ULC-S636. ULC-S636 certified plastic vent system material or the components of ULC-S636 certified vent systems must not be interchanged with other vent systems or unlisted pipe/fittings. Vent components supplied with the furnace and components in factory authorized vent kits may be used with ULC-S636 certified vent systems.

The ULC-S636 certified plastic components, and specified primers and glues of the certified system must be from a single system manufacturer and not intermixed with other system manufacturer's vent system parts.

The first 3 ft. (900 mm) of the venting system must be readily accessible for inspection.

The combustion air system is not required to be ULC-S636 certified.

On the Dual Certified furnace, the vent and combustion air pipes attach to the furnace through the top panel for the upflow and horizontal installations. For the downflow installation, the vent and combustion air pipes attach to the furnace through the alternate locations on the furnace side panels.

Note: On the Direct Vent furnace, the vent pipe attaches to the furnace through the side panels. The combustion air pipe attaches to the top panel or to the alternate location on the side panel.

On the Single Pipe furnace, the vent pipe attaches to the furnace through the furnace side panels.

Note: Repositioning of the combustion blower is required for the vent pipe connection to the furnace through the "right side" panel. See "Vent and Combustion Air Piping" section for further details.

## Horizontal Furnace Installation

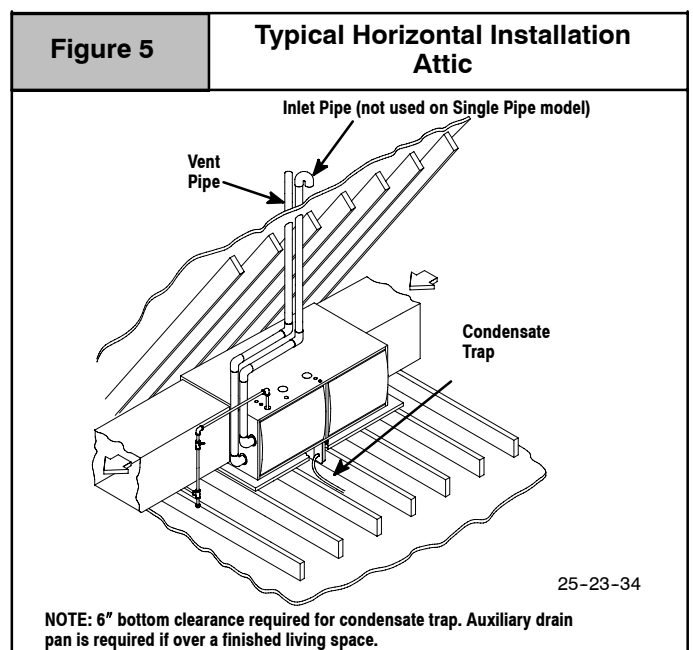

This furnace can be installed horizontally in an attic, basement, crawl space, alcove, or suspended from a ceiling in a basement or utility room. See **Figure 5**. Do not install furnace on its back or in the reverse airflow positions as safety control operation will be adversely affected.



If the furnace is to be installed in a crawl space, consult local codes. A suitable concrete pad or blocks are recommended for crawl space installation on the ground.

NOTE: 6" bottom clearance required for condensate trap.

24" between the front of the furnace and adjacent construction or other appliances **MUST** be maintained for service clearance.

Keep all insulating materials clear from louvered door. Insulating materials may be combustible.

## 3. Combustion & Ventilation Air

### For Single Pipe Installation

#### **⚠ WARNING**

**CARBON MONOXIDE POISONING HAZARD.**  
**Failure to follow this warning could result in personal injury or death.**  
**Use methods described here to provide combustion and ventilation air.**

Furnaces require ventilation openings to provide sufficient air for proper combustion and ventilation of flue gases. All duct or openings for supplying combustion and ventilation air must comply with the gas codes, or in the absence of local codes, the applicable national codes.

Combustion and ventilation air must be supplied in accordance with one of the following:

Note: The Combustion & Ventilation Air Section in this document, uses tables and information from the ANSI Z223.1/NFPA 54. For use in Canada, use CSA B149.1 for this information.

1. Section 9.3, Air for Combustion and Ventilation, of the National Fuel Gas Code, (NFGC), ANSI Z223.1-2006/NFPA 54-2006 in the U.S.,
2. Sections 8.2, 8.3, 8.5, 8.6, 8.7, and 8.8 of National Standard of Canada, Natural Gas and Propane Installation Code (NSCNGPIC), CSA B149.1-05 in Canada,
3. Applicable provisions of the local building code.

This furnace can NOT be common vented or connected to any type B, BW or L vent or vent connector, nor to any portion of a factory-built or masonry chimney. Multistory venting is NOT permitted. If this furnace is replacing a previously common-vented furnace, it may be necessary to resize the existing vent and chimney to prevent oversizing problems for the other remaining appliance(s). See "Venting and Combustion Air Check" in this section. This furnace **MUST** be vented to the outside.

The horizontal furnaces may be installed directly on combustible wood flooring or supports as long as all required furnace clearances are met. See **Figure 5**.

This furnace **MUST NOT** be installed directly on carpeting or tile or other combustible material other than wood flooring or supports.

For horizontal installation over a finished living space. A field fabricated auxiliary drain pan with drain pipe is required to prevent damage by overflow due to blocked condensate drain.

When the installation is complete, check that all appliances have adequate combustion air and are venting properly. See *Venting And Combustion Air Check* in "Gas Vent Installation" Section in this manual.

### Outdoor Combustion Air Method

A space having less than 50 cubic feet per 1,000 BTUH input rating for all gas appliances installed in the space requires outdoor air for combustion and ventilation.

### Air Openings and Connecting Ducts

1. Total input rating for all gas appliances in the space **MUST** be considered when determining free area of openings.
2. Connect ducts or openings directly to the outdoors.
3. When screens are used to cover openings, the openings **MUST** be no smaller than  $\frac{1}{4}$ " mesh.
4. The minimum dimension of air ducts **MUST NOT** be less than 3".
5. When sizing a grille, louver, or screen use the free area of opening. If free area is **NOT** stamped or marked on grill or louver, assume a 20% free area for wood and 60% for metal. Screens shall have a mesh size not smaller than  $\frac{1}{4}$ ".

### Requirements

1. Provide the space with sufficient air for proper combustion and ventilation of flue gases using horizontal or vertical ducts or openings.
2. **Figure 6** illustrates how to provide combustion and ventilation air when two permanent openings, one inlet and one outlet, are used.
  - a. One opening **MUST** commence within 12" of the floor and the second opening **MUST** commence within 12" of the ceiling.
  - b. Size openings and ducts per **Table 1**.

Figure 6

Outside Air (This is ONLY a guide. Subject to codes of country having jurisdiction.)

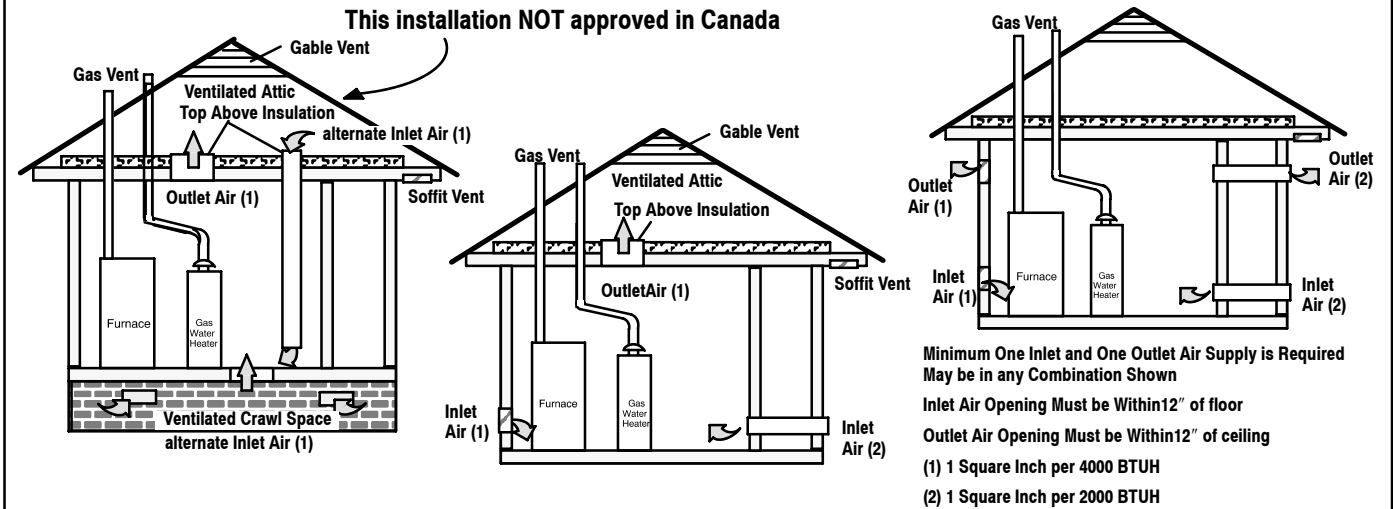

- c. Horizontal duct openings require 1 square inch of free area per 2,000 BTUH (1,100 mm<sup>2</sup>/kW) of combined input for all gas appliances in the space (see **Table 1**).
  - d. Vertical duct openings or openings directly communicating with the outdoors require 1 square inch of free area per 4,000 BTUH (550 mm<sup>2</sup>/kW) for combined input of all gas appliances in the space (see **Table 1**).
3. When one permanent outdoor opening is used, the opening requires:
- a. 1 sq. in. of free area per 3,000 BTUH (700 mm<sup>2</sup>/kW) for combined input of all gas appliances in the space (see **Table 1**) and
  - b. not less than the sum of the areas of all vent connectors in the space.
- The opening shall commence within 12" of the top of the enclosure. Appliances shall have clearances of at least 1" from the sides and back and 6" from the front. The opening shall directly communicate with the outdoors or shall communicate through a vertical or horizontal duct to the outdoors or spaces (crawl or attic) that freely communicate with the outdoors.
4. Combination of Indoor and Outdoor Air shall have:
- a. Indoor openings that comply with the **Indoor Combustion Air** Method below and
  - b. Outdoor openings located as required in the **Outdoor Combustion Air** Method above and
  - c. Outdoor openings sized as follows.
    - 1) Calculate the **Ratio** of all Indoor Space volume divided by required volume for **Indoor Combustion Air** Method.
    - 2) Outdoor opening size reduction **Factor** is 1 minus the **Ratio** in 1) above.
    - 3) Minimum size of Outdoor openings shall be the size required in **Outdoor Combustion Air** Method above multiplied by reduction **Factor**.

Table 1		Free Area			
BTUH Input Rating	Minimum Free Area Required for Each Opening or Duct to Outdoors				
	Two Horizontal Ducts (sq. in./2,000 BTUH)	Single Opening (sq. in./3,000 BTUH)	Two Vertical Ducts or Openings (sq. in./4,000 BTUH)	Round Duct (sq. in. /4,000 BTUH)	
40,000	20 sq. in.	13.3 sq. in.	10.0 sq. in.	4"	
50,000	25 sq. in.	16.7 sq. in.	12.5 sq. in.	4"	
60,000	30 sq. in.	20 sq. in.	15.0 sq. in.	4"	
75,000	37.5 sq. in.	25 sq. in.	18.75 sq. in.	5"	
80,000	40 sq. in.	26.7 sq. in.	20.0 sq. in.	5"	
100,000	50 sq. in.	33.3 sq. in.	25 sq. in.	6"	
125,000	62.50 sq. in.	41.7 sq. in.	31.25 sq. in.	7"	

**EXAMPLE:** Determining Free Area

Furnace		Water Heater		Total Input	
100,000	+	30,000	=	(130,000 ÷ 4,000)	= 32.5 Sq. In. Vertical
Furnace		Water Heater		Total Input	
100,000	+	30,000	=	(130,000 ÷ 2,000)	= 65 Sq. In. Horizontal

# Indoor Combustion Air

⚠ WARNING

**CARBON MONOXIDE POISONING HAZARD.**

**Failure to follow this warning could result in personal injury or death.**

**Most homes will require additional air from outdoors for combustion and ventilation. A space with at least 50 cubic feet per 1,000 BTUH input rating or homes with tight construction may need outdoor air, supplied through ducts, to supplement air infiltration for proper combustion and ventilation of flue gases.**

# Standard and Known-Air-Infiltration Rate Methods

© NFPA & AGA

**Indoor air** is permitted for combustion and ventilation, if the **Standard** or **Known-Air-Infiltration Rate** Method is used.

The **Standard** Method may be used, if the space has no less volume than 50 cubic feet per 1,000 BTUH input rating for all gas appliances installed in the space. The **standard** method permits indoor air to be used for combustion and ventilation air.

The **Known Air Infiltration Rate** Method shall be used if the infiltration rate is known to be less than 0.40 air changes per hour (ACH) and equal to or greater than 0.10 ACH. Infiltration rates greater than 0.60 ACH shall not be used. The minimum required volume of the space varies with the number of ACH and shall be determined per **Table 2** or **Equations 1 and 2**. Determine the minimum required volume for each appliance in the space, and add the volumes together to get the total minimum required volume for the space.

Table 2		MINIMUM SPACE VOLUME FOR 100% COMBUSTION AND VENTILATION AIR FROM INDOORS (ft <sup>3</sup> )							
		Other Than Fan-Assisted Total (1,000's Btuh)			Fan-assisted Total (1,000's Btuh)				
ACH	30	40	50	40	50	60	75	100	125
0.60	1,050	1,400	1,750	1,000	1,250	1,500	1,875	2,500	3,125
0.50	1,260	1,680	2,100	1,200	1,500	1,800	2,250	3,000	3,750
0.40	1,575	2,100	2,625	1,500	1,875	2,250	2,813	3,750	4,688
0.30	2,100	2,800	3,500	2,000	2,500	3,000	3,750	5,000	6,250
0.20	3,150	4,200	5,250	3,000	3,750	4,500	5,625	7,500	9,375
0.10	6,300	8,400	10,500	6,000	7,500	9,000	11,250	15,000	18,750
0.00	NP	NP	NP	NP	NP	NP	NP	NP	NP

NP = Not Permitted

**Table 2 Minimum Space Volumes** were determined by using the following equations from the National Fuel Gas Code ANSI Z223.1/NFPA 54-2006, 9.3.2.2:

1. For **other than fan-assisted appliances** such as a draft hood-equipped water heater,

$$\text{Volume}_{\text{other}} = \frac{21 \text{ ft}^3}{\text{ACH}} \left( \frac{I_{\text{other}}}{1000 \text{ Btu/hr}} \right)$$

2. For **fan-assisted appliances** such as this furnace,

$$\text{Volume}_{\text{fan}} = \frac{15 \text{ ft}^3}{\text{ACH}} \left( \frac{I_{\text{fan}}}{1000 \text{ Btu/hr}} \right)$$

If:

$I_{\text{other}}$  = combined input of all **other than fan-assisted appliances** in Btu/hr

$I_{\text{fan}}$  = combined input of all **fan-assisted appliances** in Btu/hr

**ACH** = air changes per hour (ACH shall not exceed 0.60).

The following requirements apply to the **Standard** Method and to the **Known Air Infiltration Rate** Method.

- Adjoining rooms can be considered part of a space, if there are no closable doors between rooms.
- Combining spaces on the same floor level. Each opening shall have a free area of at least 1 in<sup>2</sup>/1,000 BTUH (2,000 mm<sup>2</sup>/kW) of the total input rating of all gas appliances in the space, but not less than 100 in<sup>2</sup> (0.06 m<sup>2</sup>). One opening shall commence within 12" of the ceiling and the second opening

shall commence within 12" of the floor. The minimum dimension of air openings shall be at least 3".

- Combining spaces on different floor levels. The volumes of spaces on different floor levels shall be considered communicating spaces if connected by one or more permanent openings in doors or floors having a free area of at least 2 in<sup>2</sup>/1,000 Btuh (4,400 mm<sup>2</sup>/kW) of total input rating of all gas appliances.
- An attic or crawl space may be considered a space that freely communicates with the outdoors provided there are adequate ventilation openings directly to outdoors. Openings **MUST** remain open and **NOT** have any means of being closed off. Ventilation openings to outdoors **MUST** be at least 1 square inch of free area per 4,000 BTUH of total input rating for all gas appliances in the space.
- In spaces that use the **Indoor Combustion Air** Method, infiltration should be adequate to provide air for combustion, ventilation and dilution of flue gases. However, in buildings with unusually tight construction, additional air **MUST** be provided using the methods described in section titled **Outdoor Combustion Air Method**:
- Unusually tight construction is defined as Construction with:
  1. Walls and ceilings exposed to the outdoors have a continuous, sealed vapor barrier. Openings are gasketed or sealed and
  2. Doors and openable windows are weather stripped and
  3. Other openings are caulked or sealed. These include joints around window and door frames, between sole plates and floors, between wall-ceiling joints, between wall panels, at penetrations for plumbing, electrical and gas lines, etc.

## Ventilation Air

Some provincial codes and local municipalities require ventilation or make-up air be brought into the conditioned space as replacement air. Whichever method is used, the mixed return air temperature across the heat exchanger **MUST** not fall below 60° so that flue gases will not condense excessively in the heat exchanger. Excessive condensation will shorten the life of the heat exchanger and possibly void your warranty.

## Venting and Combustion Air Check

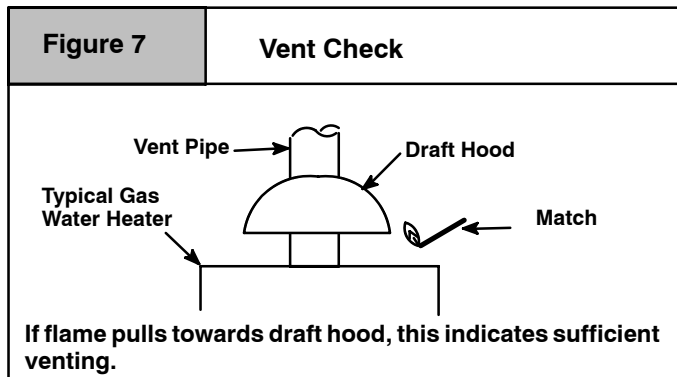

**NOTE:** When an existing Category I furnace is removed or replaced, the original venting system may no longer be sized to properly vent the attached appliances, and to make sure there is adequate combustion air for all appliances, **MAKE THE FOLLOWING CHECK.**

## **WARNING**

### **CARBON MONOXIDE POISONING HAZARD.**

**Failure to follow the steps outlined below for each appliance connected to the venting system being placed into operation, could result in carbon monoxide poisoning or death:**

**The following steps shall be followed for each appliance connected to the venting system being placed into operation, while all other appliances connected to the venting system are not in operation:**

1. Seal any unused openings in the venting system.
2. Inspect the venting system for proper size and horizontal pitch, as required in the *National Fuel Gas Code, ANSI Z223.1/NFPA 54* or *CSA B149.1, Natural Gas and Propane Installation Code* and these instructions. Determine that there is no blockage or restriction, leakage, corrosion and other deficiencies which could cause an unsafe condition.
3. As far as practical, close all building doors and windows and all doors between the space in which the appliance(s) connected to the venting system are located and other spaces of the building.
4. Close fireplace dampers.
5. Turn on clothes dryers and any appliance not connected to the venting system. Turn on any exhaust fans, such as range hoods and bathroom exhausts, so they are operating at maximum speed. Do not operate a summer exhaust fan.
6. Follow the lighting instructions. Place the appliance being inspected into operation. Adjust the thermostat so appliance is operating continuously.
7. Test for spillage from draft hood equipped appliances at the draft hood relief opening after 5 minutes of main burner operation. Use the flame of a match or candle. (**Figure 7**)
8. If improper venting is observed, during any of the above tests, the venting system must be corrected in accordance with the *National Fuel Gas Code, ANSI Z223.1/NFPA 54* and/or *CSA B149.1, Natural Gas and Propane Installation Code*.
9. After it has been determined that each appliance connected to the venting system properly vents when tested as outlined above, return doors, windows, exhaust fans, fireplace dampers and any other gas-fired burning appliance to their previous conditions of use.

## **For Two Pipe Installation**

This furnace can NOT be common vented or connected to any type B, BW or L vent or vent connector, nor to any portion of a factory-built or masonry chimney. If this furnace is replacing a previously common-vented furnace, it may be necessary to resize the existing vent and chimney to prevent oversizing problems for the other remaining appliance(s). See "Venting and Combustion Air Check" in this section. This furnace **MUST** be vented to the outside.

## 4. Vent and Combustion Air Piping

**⚠ WARNING**

**CARBON MONOXIDE POISONING HAZARD.**  
**Failure to follow this warning could result in personal injury or death.**  
**Use methods described here to provide combustion and ventilation air.**

### Single Pipe (N9MP1 Models)

This furnace is certified as a category IV appliance. This furnace requires ventilation openings to provide air for proper combustion and ventilation of flue gases. All duct or openings for supplying combustion and ventilation air must comply with the gas codes or in absence of local codes, the applicable national codes.

When the installation is complete, see the “*Venting and Combustion Air Check*” in this manual.

### Direct Vent (N9MP2 Models)

This furnace is certified as a category IV appliance. This furnace uses outside air for combustion ONLY, it **MUST** be taken from the same atmospheric pressure zone as the vent pipe. See **Confined Space Installation** in the **Combustion and Ventilation Air** in this manual.

### Dual Certified (N9MPD and \*9MPD Models)

This furnace is certified as a category IV appliance. This furnace can be installed as a direct vent furnace using outside air for combustion or the furnace can use air from inside the structure for combustion. The **INLET** air pipe is optional. If combustion air comes from inside the structure, adequate make up air **MUST** be provided to compensate for oxygen burned. See **Confined Space Installation** in the **Combustion and Ventilation Air** chapter. If combustion air is drawn from outside the structure, it **MUST** be taken from the same atmospheric pressure zone as the vent pipe.

### Contaminated Combustion Air

Installations in certain areas or types of structures will increase the exposure to chemicals or halogens that may harm the furnace.

The following areas or types of structures may contain or have exposure to the substances listed below. The installation must be evaluated carefully as it may be necessary to provide outside air for combustion.

- Commercial buildings.
- Buildings with indoor pools.
- Furnaces installed in laundry rooms.
- Furnaces installed in hobby or craft rooms.
- Furnaces installed near chemical storage areas.
- Permanent wave solutions for hair.
- Chlorinated waxes and cleaners.
- Chlorine based swimming pool chemicals.
- Water softening chemicals.
- De-icing salts or chemicals.
- Carbon tetrachloride.
- Halogen type refrigerants.
- Cleaning solvents (such as perchloroethylene).
- Printing inks, paint removers, varnishes, etc.

- Hydrochloric acid.
- Sulfuric Acid.
- Solvent cements and glues.
- Antistatic fabric softeners for clothes dryers.
- Masonry acid washing materials.

### Vent and Combustion Air Piping Guidelines

This furnace is approved for venting with Schedule 40 PVC, CPVC, ABS fittings, and Cellular Core and SDR-26 PVC pipe.

Applicable ASTM Standards for Vent Materials						
Materials	Sch. 40 Pipe	SDR Pipe	Cell Core Pipe	Fittings	Primer	Solv. Cement
ABS	D1527	—	F628	D2468 & D2661	--	D2235
PVC	D1785	D2241	F891	D2466 & D2665	F656	D2564
CPVC	F441	F442	--	F438	--	F493
ABS to PVC	--	--	--	--	--	D3138

**NOTE:** 1) In Canada, all pipe, fittings & cements must conform to applicable CSA standards or to local codes having jurisdiction.

2) Only use solvent cements that are marked for use with the specific venting material.

3) ABS to PVC transition joints REQUIRE a special solvent cement that meets the requirements of ASTM D3138.

4) Refer to ASTM D2855 for general procedure to use for cementing plastic pipe and fittings.

**NOTE:** In order to create a seal that allows future removal of pipe, **RTV sealant MUST be used on the inlet pipe** where it joins to the furnace.

**NOTE:** All vent piping **MUST** be installed in compliance with local codes or ordinances, these instructions, good trade practices, and codes of country having jurisdiction.

1. Determine the best routing and termination for the vent pipe and air inlet pipe by referring to all of the instructions and guidelines in this Section.
2. Determine the size required for the vent pipe and air inlet pipe.
3. Loosely assemble all venting parts without adhesive (pipe joint cement) for correct fit before final assembly.
4. Furnace shall be installed so as to prevent the accumulation of condensate.
5. Use of vertical piping is preferred because there will be some moisture in the flue gases that may condense as it leaves the vent pipe (See *Instruction For Horizontal Vents*).
6. The vertical vent pipe **MUST** be supported so that no weight is allowed to rest on the combustion blower.
7. Exhaust vent piping or air inlet piping diameter **MUST NOT** be reduced.
8. All exhaust vent piping from the furnace to termination **MUST** slope upwards. A minimum of 1/4" per foot per 30.5cm) of run is required to properly return condensate to the furnace drain system.

9. Use DWV type long radius elbows whenever possible, as they provide for the minimum slope on horizontal runs and they provide less resistance in the vent system. If DWV elbows cannot be used, use two, 45° elbows when possible. On horizontal runs the elbows can be slightly misaligned to provide the correct slope.
10. All horizontal pipe runs **MUST** be supported at least every five feet with galvanized strap or other rust resistant material. **NO** sags or dips are permitted.
11. All vertical pipe runs **MUST** be supported every six feet where accessible.
12. The minimum pipe run length is 2'.
13. The piping can be run in the same chase or adjacent to supply or vent pipe for water supply or waste plumbing. It can also be run in the same chase with a vent from another 90+ furnace.

**NOTE:** In **NO** case can the piping be run in a chase where temperatures can exceed 140° F(60°C) . or where radiated heat from adjacent surfaces would exceed 140° F.

14. The vent outlet **MUST** be installed to terminate in the same atmospheric pressure zone as the combustion air inlet.
15. The vent system can be installed in an existing unused chimney provided that:
  - Both the exhaust vent and air intake run the length of the chimney.
  - No other gas fired appliance or fireplace (solid fuel) is vented into the chimney.
  - The top of the chimney **MUST** be sealed flush or crowned up to seal against rain or melting snow so **ONLY** the piping protrudes.
  - The termination clearances shown in **Figure 8 & Figure 9** are maintained.
16. Furnace applications with vertical vents requiring vent diameter increaser fittings **must** have increaser fittings installed in vertical portion of the vent. Condensate will be trapped in the vent if the vent diameter is increased prior to having an elbow turned upward. This could cause nuisance tripping of the pressure switch.

## Combustion Air and Vent Piping Insulation Guidelines

**NOTE:** Use closed cell, neoprene insulation or equivalent. If Fiberglass or equivalent insulation is used it must have a vapor barrier. Use R values of 7 up to 10', R-11 if exposure exceeds 10'. If Fiberglass insulation is used, exterior to the structure, the pipe **MUST** be boxed in and sealed against moisture.

1. When the vent or combustion air pipe height above the roof exceeds 30", or if an exterior vertical riser is used on a horizontal vent to get above snow levels, the exterior portion **MUST** be insulated.
2. When combustion air inlet piping is installed above a suspended ceiling, the pipe **MUST** be insulated with moisture resistant insulation such as Armaflex or other equivalent type of insulation.
3. Insulate combustion air inlet piping when run in warm, humid spaces.

## Sizing Combustion Air and Vent Pipe

Consult **Table 3** or **Table 4** to select the proper diameter exhaust and combustion air piping. Exhaust and combustion air piping is sized for each furnace Btuh size based on total lineal vent length (on inlet **or** outlet side), and number of 90° elbows required. Two 45° elbows can be substituted for one 90° elbow. The elbow or elbows used for vent termination outside the structure **ARE** counted, including elbows needed to bring termination above expected snow levels. The elbow inside the furnace on the N9MPD and \*9MPD **IS NOT** included in the count.

Table 3	Pipe Diameter Table N9MP1, N9MPD & *9MPD Models
<b>40,000, 50,000, 60,000, 75,000 &amp; 80,000 Btuh Furnaces</b>	
40' & (5) 90° elbows with 2" PVC pipe or 70' & (5) 90° elbows with 3" PVC pipe	
<b>100,000 Btuh Furnace</b>	
40' & (5) 90° elbows with 3" PVC pipe or 70' & (5) 90° elbows with 3" PVC pipe & Long Vent Kit (See Tech. Manual)	
<b>125,000 Btuh Furnace</b>	
40' & (5) 90° elbows with 3" PVC pipe	
<b>Elbows are DWV Long Radius Type for 2" and 3" vents.</b>	

If more than five elbows are required, **REDUCE** the length of both the inlet and exhaust pipes 5' for each additional elbow used. If less than five elbow are required, the length can be **INCREASED** by 5' for each additional elbow **NOT** used.

**NOTE:** It is allowable to use larger diameter pipe and fitting than shown in the tables but **not** smaller diameters than shown.

Table 4	Pipe Diameter Table N9MP2 Models
<b>50,000 &amp; 80,000 Btuh Furnaces</b>	
40' & (5) 90° elbows with 2" PVC pipe or 70' & (5) 90° elbows with 3" PVC pipe	
<b>75,000 Btuh Furnaces</b>	
25' & (3) 90° elbows with 2" PVC pipe or 40' & (5) 90° elbows with 2" PVC pipe & Long Vent Kit (See Tech. Manual) or 70' & (5) 90° elbows with 3" PVC pipe	
<b>100,000 Btuh Furnace</b>	
40' & (5) 90° elbows with 3" PVC pipe or 70' & (5) 90° elbows with 3" PVC pipe & Long Vent Kit (See Tech. Manual)	
<b>125,000 Btuh Furnace</b>	
40' & (5) 90° elbows with 3" PVC pipe	
<b>Elbows are DWV Long Radius Type for 2" and 3" vents.</b>	

If more than five elbows are required, **REDUCE** the length of both the inlet and exhaust pipes 5' for each additional elbow used. If less than five elbows are required, the length can be **INCREASED** by 5' for each additional elbow **NOT** used.

**NOTE:** It is allowable to use larger diameter pipe and fitting than shown in the tables but **not** smaller diameters than shown.

For "**Concentric Termination Kit**" Venting table in this manual.

### Vent Termination Clearances

	<h1 style="margin: 0;">WARNING</h1>
<p><b>CARBON MONOXIDE POISONING.</b> Failure to follow this warning could result in personal injury or death. Inlet and outlet pipes may <b>NOT</b> be vented directly above each other.</p>	

1. Determine termination locations based on clearances specified in following steps and as shown in **Figure 8, Figure 9, Figure 22, through Figure 30.**

For "**Concentric Termination Kit**" clearances, see **Figure 31, through Figure 35** in this manual.

2. For Single Pipe Installation, models N9MP1, N9MPD or \*9MPD, refer to **Figure 9** for vent termination clearances.
3. For Direct Vent Installation, models N9MP2, N9MPD or \*9MPD, refer to **Figure 8** for vent termination clearances.

Figure 8

Direct Vent Termination Clearance

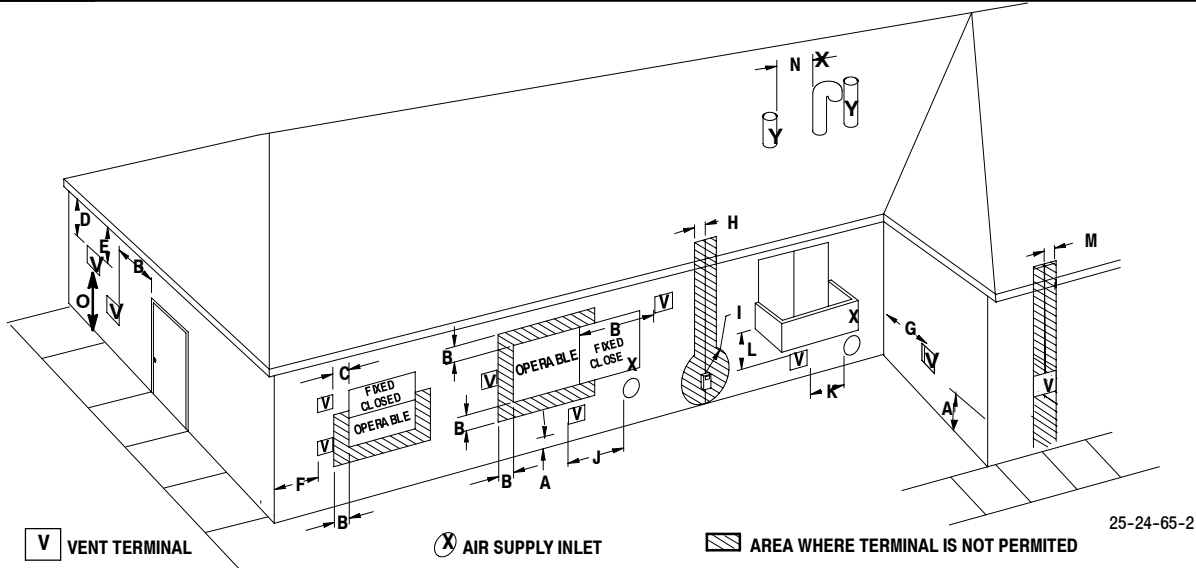

25-24-65-2

V VENT TERMINAL

X AIR SUPPLY INLET

AREA WHERE TERMINAL IS NOT PERMITTED

Item	Clearance Description	Canadian Installation (1)	U.S. Installation (2)
A	Clearance above grade, veranda, porch, deck, balcony, or anticipated snow level	12" (30cm) #	12" (30 cm)
B	Clearance to a window or door that may be opened	6" (15 cm) for appliances ≤ 10,000 BTUH (3kW), 12" (30 cm) for appliances > 10,000 Btuh (3 kW) and ≤ 100,000 Btuh (30 kW), 36" (91 cm) for appliances > 100,000 Btuh (30 kW)	6" (15 cm) for appliances ≤ 10,000 BTUH (3kW), 9" (23 cm) for appliances > 10,000 Btuh (3 kW) and ≤ 50,000 Btuh (15 kW), 12" (30 cm) for appliances > 50,000 Btuh (15 kW)
C	Clearance to a permanently closed window	*	*
D	Vertical clearance to a ventilated soffit located above the terminal within a horizontal distance of 2' (61cm) from the centerline of the terminal	*	*
E	Clearance to an unventilated soffit	*	*
F	Clearance to an outside corner	*	*
G	Clearance to an inside corner	*	*
H	Clearance to each side of the centerline extended above electrical meter or gas service regulator assembly	3' (91 cm) within 15' (4.5 m) above the meter/regulator assembly	*
I	Clearance to service regulator vent outlet	3' (91 cm)	*
J	Clearance to non-mechanical air supply inlet to building or the combustion air inlet to any other appliance	6" (15 cm) for appliances ≤ 10,000 BTUH (3kW), 12" (30 cm) for appliances > 10,000 Btuh (3 kW) and ≤ 100,000 Btuh (30 kW), 36" (91 cm) for appliances > 100,000 Btuh (30 kW)	6" (15 cm) for appliances ≤ 10,000 BTUH (3kW), 9" (23 cm) for appliances > 10,000 Btuh (3 kW) and ≤ 50,000 Btuh (15 kW), 12" (30 cm) for appliances > 50,000 Btuh (15 kW)
K	Clearance to a mechanical air supply inlet	6' (1.83 m)	3' (91 cm) above if within 10' (3m) horizontally
L	Clearance under a veranda, porch, deck, or balcony	12" (30 cm) ‡	*
M	Clearance to each side of the centerline extended above or below vent terminal of the furnace to a dryer or water heater vent, or other appliance's direct vent intake or exhaust.	12" (30 cm)	12" (30 cm)
N	Clearance from a plumbing vent stack	3' (91 cm)	3' (91 cm)
O	Clearance above a paved sidewalk or paved driveway located on public property.	7' (2.13 m) +	*

(1.) In accordance with the current CSA B149.1, Natural Gas and Propane Installation Code

(2.) In accordance with the current ANSI Z223.1/NFPA 54, National Fuel Gas Code

# 18" (46 cm) above roof surface

+ A vent shall not terminate directly above a sidewalk or paved driveway that is located between two single family dwellings and serves both dwellings.

‡ Permitted only if veranda, porch, deck, or balcony is fully open on a minimum of two sides beneath the floor.

\* For clearances not specified in ANSI Z223.1/NFPA 54 or CSA B149.1, clearances shall be in accordance with local installation codes and the requirements of the gas supplier and the manufacture's installation instructions.

Notes:

1. The vent for this appliance shall not terminate
  - a. Near soffit vents or crawl space vents or other areas where condensate or vapor could create a nuisance or hazard or property damage; or
  - b. Where condensate vapor could cause damage or could be detrimental to the operation of regulators, relief valves, or other equipment.
2. When locating vent terminations, consideration must be given to prevailing winds, location, and other conditions which may cause recirculation of the combustion products of adjacent vents. Recirculation can cause poor combustion, inlet condensate problems, and accelerated corrosion of the heat exchangers.

Figure 9

Other than Direct Vent Termination Clearance

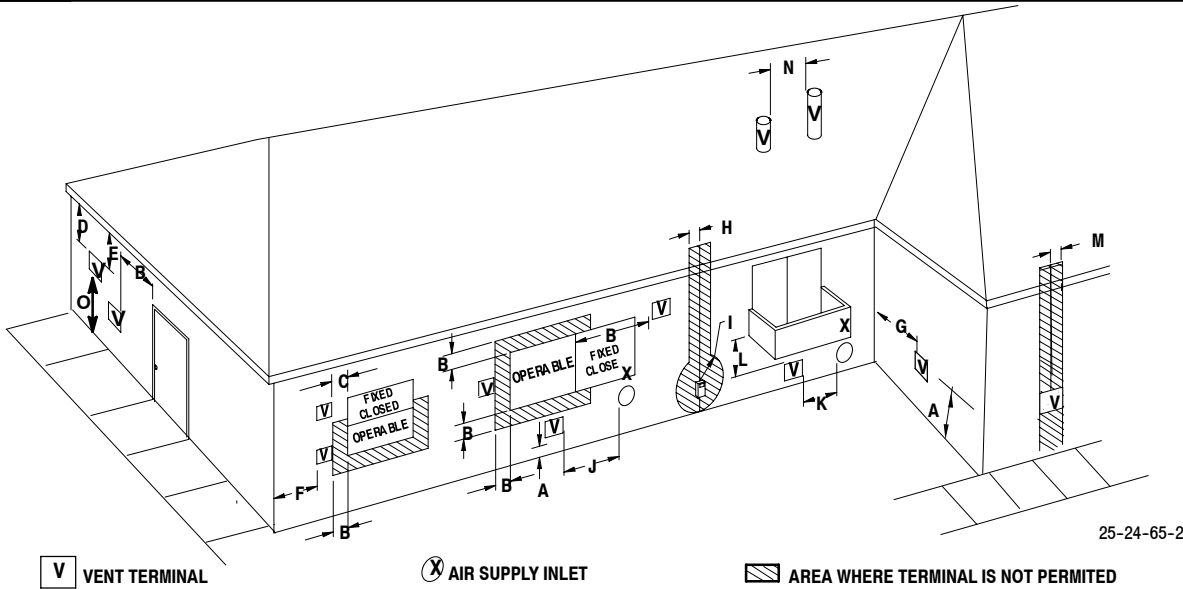

Item	Clearance Descriptions	Canadian Installation (1)	U.S. Installation (2)
A	Clearance above grade, veranda, porch, deck, balcony, or anticipated snow level	12" (30cm) #	12" (30 cm)
B	Clearance to a window or door that may be opened	6" (15 cm) for appliances ≤ 10,000 BTUH (3kW), 12" (30 cm) for appliances > 10,000 Btuh (3 kW) and ≤ 100,000 Btuh (30 kW), 36" (91 cm) for appliances > 100,000 Btuh (30 kW)	4' (1.2 m) below or to the side of the opening. 1' (30 cm) above the opening.
C	Clearance to a permanently closed window	*	*
D	Vertical clearance to a ventilated soffit located above the terminal within a horizontal distance of 2' (61cm) from the centerline of the terminal	*	*
E	Clearance to an unventilated soffit	*	*
F	Clearance to an outside corner	*	*
G	Clearance to an inside corner	*	*
H	Clearance to each side of the centerline extended above electrical meter or gas service regulator assembly	3' (91 cm) within 15' (4.5 m) above the meter/regulator assembly	*
I	Clearance to service regulator vent outlet	3' (91 cm)	*
J	Clearance to non-mechanical air supply inlet to building or the combustion air inlet to any other appliance	6" (15 cm) for appliances ≤ 10,000 BTUH (3kW), 12" (30 cm) for appliances > 10,000 Btuh (3 kW) and ≤ 100,000 Btuh (30 kW), 36" (91 cm) for appliances > 100,000 Btuh (30 kW)	4' (1.2 m) below or to the side of opening; 1' (30 cm) above opening.
K	Clearance to a mechanical air supply inlet	6' (1.83 m)	3' (91 cm) above if within 10' (3m) horizontally
L	Clearance under a veranda, porch, deck, or balcony	12" (30 cm) ‡	*
M	Clearance to each side of the centerline extended above or below vent terminal of the furnace to a dryer or water heater vent, or other appliance's direct vent intake or exhaust.	*	*
N	Clearance from a plumbing vent stack	3' (91 cm)	3' (91 cm)
O	Clearance above a paved sidewalk or paved driveway located on public property.	7' (2.13 m) +	7' (2.13 m)

(1.) In accordance with the current CSA B149.1, Natural Gas and Propane Installation Code

(2.) In accordance with the current ANSI Z223.1/NFPA 54, National Fuel Gas Code

# 18" (46 cm) above roof surface

+ A vent shall not terminate directly above a sidewalk or paved driveway that is located between two single family dwellings and serves both dwellings.

‡ Permitted only if veranda, porch, deck, or balcony is fully open on a minimum of two sides beneath the floor.

\* For clearances not specified in ANSI Z223.1/NFPA 54 or CSA B149.1, clearances shall be in accordance with local installation codes and the requirements of the gas supplier and the manufacturer's installation instructions.

**Notes:**

1. The vent for this appliance shall not terminate
  - a. Near soffit vents or crawl space vents or other areas where condensate or vapor could create a nuisance or hazard or property damage; or
  - b. Where condensate vapor could cause damage or could be detrimental to the operation of regulators, relief valves, or other equipment.
2. When locating vent terminations, consideration must be given to prevailing winds, location, and other conditions which may cause recirculation of the combustion products of adjacent vents. Recirculation can cause poor combustion, inlet condensate problems, and accelerated corrosion of the heat exchangers.



## Condensate Drain Trap

This furnace removes both sensible and latent heat from the products of combustion. Removal of the latent heat results in condensation of the water vapor. The condensate is removed from the furnace through the drains in the plastic transition and the vent fitting. The drains connect to the externally mounted condensate drain trap on the left or right side of the furnace.

The startup of a new furnace will involve a cycle or two of the furnace to properly prime the condensate trap with water. Until the trap is fully primed, some condensate will be pulled into the combustion blower. The furnace may cycle on the pressure switch connected to the plastic transition box due to condensate buildup. After the trap is primed, the condensate will start draining from the furnace. The combustion blower will clear out any remaining condensate in the blower housing through the vent fitting downstream of the blower. Note that the condensate trap can also be primed by pouring water into the  $\frac{1}{2}$ " drain hose. Remove the  $\frac{1}{2}$ " ID drain hose from either the gutter or the white PVC tee trap. Using a funnel pour eight (8) ounces of water into  $\frac{1}{2}$ " ID drain hose. Water will flow through the drain hose and into the condensate drain trap. This will prime both the vent and the transition sides of the trap. Reconnect the  $\frac{1}{2}$ " ID drain hose to the original component, either the gutter or the PVC tee trap.

The condensate drain trap supplied with the furnace **MUST** be used. The drain connection on the condensate drain trap is sized for  $\frac{3}{4}$ " PVC or CPVC pipe, however alternate  $\frac{1}{2}$ " CPVC (nominal  $\frac{5}{8}$ " O.D.) or vinyl tubing with a minimum inner diameter (I.D.) of  $\frac{5}{8}$ " may also be used, as allowed by local codes. Alternate drain pipes and hoses may be used as allowed by local codes.

The drain line must maintain a  $\frac{1}{4}$ " per foot downward slope toward the drain.  $\frac{1}{4}$ " per foot is recommended. Installation of an overflow line is recommended when the  $\frac{1}{4}$ " per foot slope to the condensate drain cannot be maintained. A drain tube retainer clip is included in the furnace to prevent kinking/buckling of the drain tube. The retainer clip should remain in the furnace (between the door switch plate and the blower shelf, **Figure 10**) during operation. See **Figure 20** for proper routing and installation of the overflow.

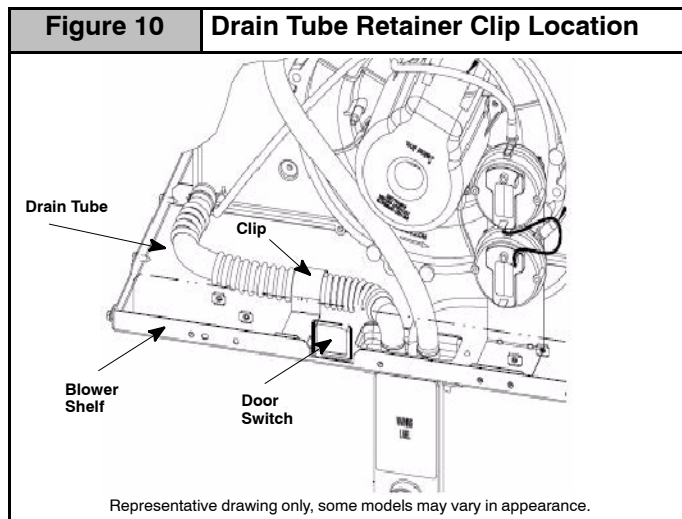

DO NOT trap the drain line in any other location than at the condensate drain trap supplied with the furnace.

**CAUTION**

**FROZEN AND BURST WATER PIPE HAZARD.**  
Failure to follow this caution may result in property damage.

**If a condensate pump is installed, a plugged condensate drain or a failed pump may cause the furnace to shut down. Do not leave the home unattended during freezing weather without turning off water supply and draining water pipes or otherwise protecting against the risk of frozen pipes.**

If possible, DO NOT route the drain line where it may freeze. The drain line must terminate at an inside drain to prevent freezing of the condensate and possible property damage.

1. A condensate sump pump **MUST** be used if required by local codes, or if no indoor floor drain is available. The condensate pump must be approved for use with acidic condensate.
2. A plugged condensate drain line or a failed condensate pump will allow condensate to spill. If the furnace is installed where a condensate spill could cause damage, it is recommended that an auxiliary safety switch be installed to prevent operation of the equipment in the event of pump failure or plugged drain line. If used, an auxiliary safety switch should be installed in the R circuit (low voltage) **ONLY**.
3. If the auxiliary switch in the condensate pump is used, the furnace may shut down due to a blocked condensate line or failed pump. To prevent frozen water pipes see the "Frozen Water Pipe Hazard" section in this manual.

## Condensate Drain Trap Freeze Protection

Special precautions **MUST** be made if installing furnace in an area which may drop below freezing. This can cause improper operation or damage to the equipment. If the the furnace environment has the potential of freezing, the drain trap and drain line must be protected. Use 3 to 6 watt per foot at 115 volt, 40° F self-regulating shielded and waterproof heat tape. Wrap the drain trap and drain line with the heat tape and secure with the ties. Follow the heat tape manufacturer's recommendations.

Figure 11

Upflow Installations Top Vent

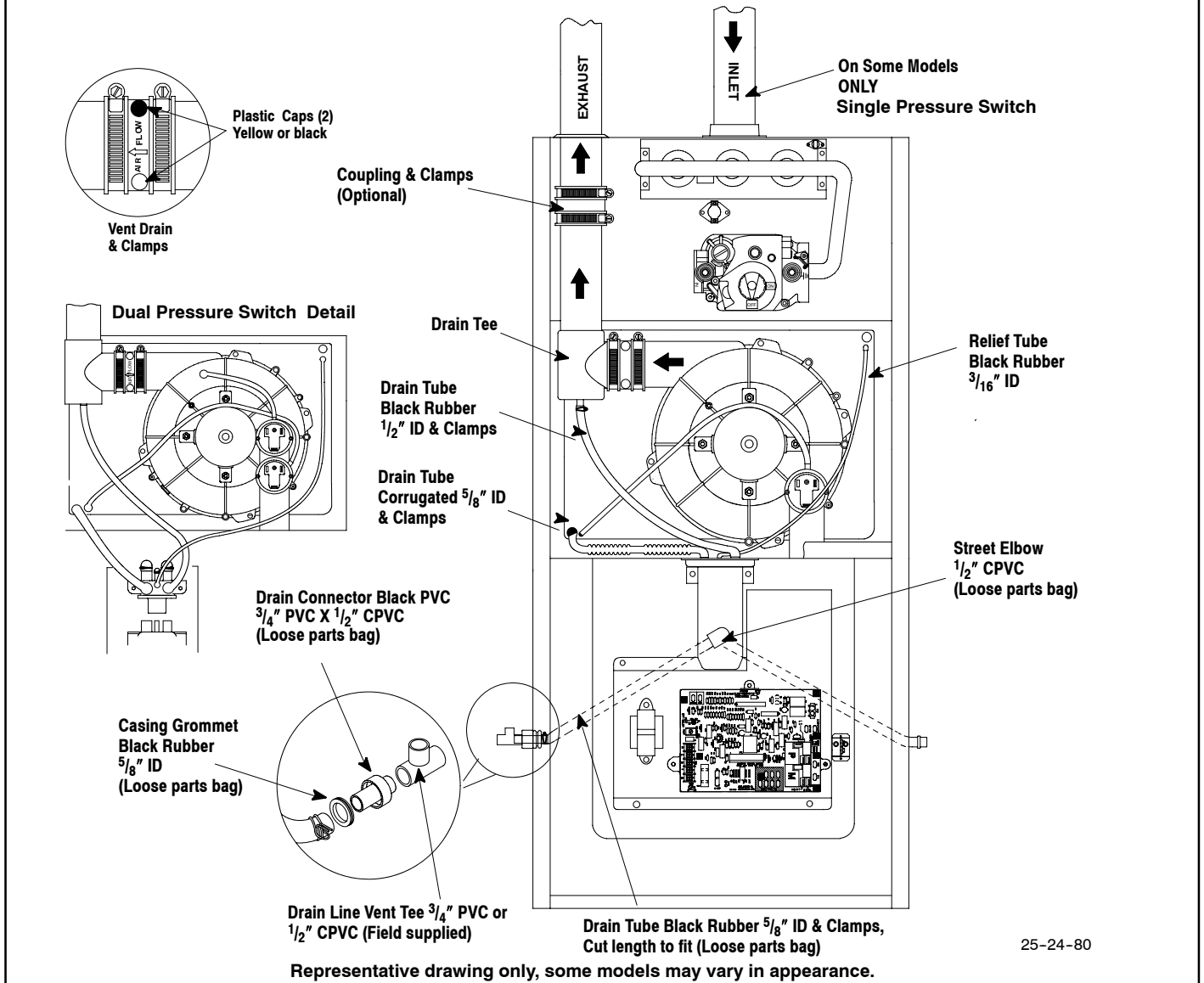

Upflow Installations Top Vent (See Figure 11)

Remove knockout from the side of the furnace casing where drain tube will exit.

Install casing grommet (black rubber 5/8" ID grommet - in loose parts bag)

Install the 1/2" CPVC street elbow on discharge of trap

Install the black PVC tube connector (3/4" PVC x 1/2" CPVC from loose parts bag) as shown in the illustration above.

Cut the black drain tube (5/8" ID - in loose parts bag) to length to fit between trap and tube connector through grommet.

Clamp both ends of the drain tube using clamps provided.

Glue the CPVC street elbow to the trap using appropriate cleaner and solvent cement.

The field supplied 3/4" PVC or 1/2" CPVC drain line vent tee must vent outside the furnace cabinet (see exploded view above).

**Note:** It is recommended that all PVC piping and fitting connections be fit up and inspected before final cementing. **Trap must be primed before operation.** Verify all condensate drain connections are securely clamped. A coupling and clamps (in loose part bag) may be installed as shown for future servicing of the vent system.

**NOTE:** "PVC" is used as a generic term. Pipe and fitting materials used must be acceptable to the local code officials having jurisdiction.

Figure 12

Upflow Installations Vent through Left-Side

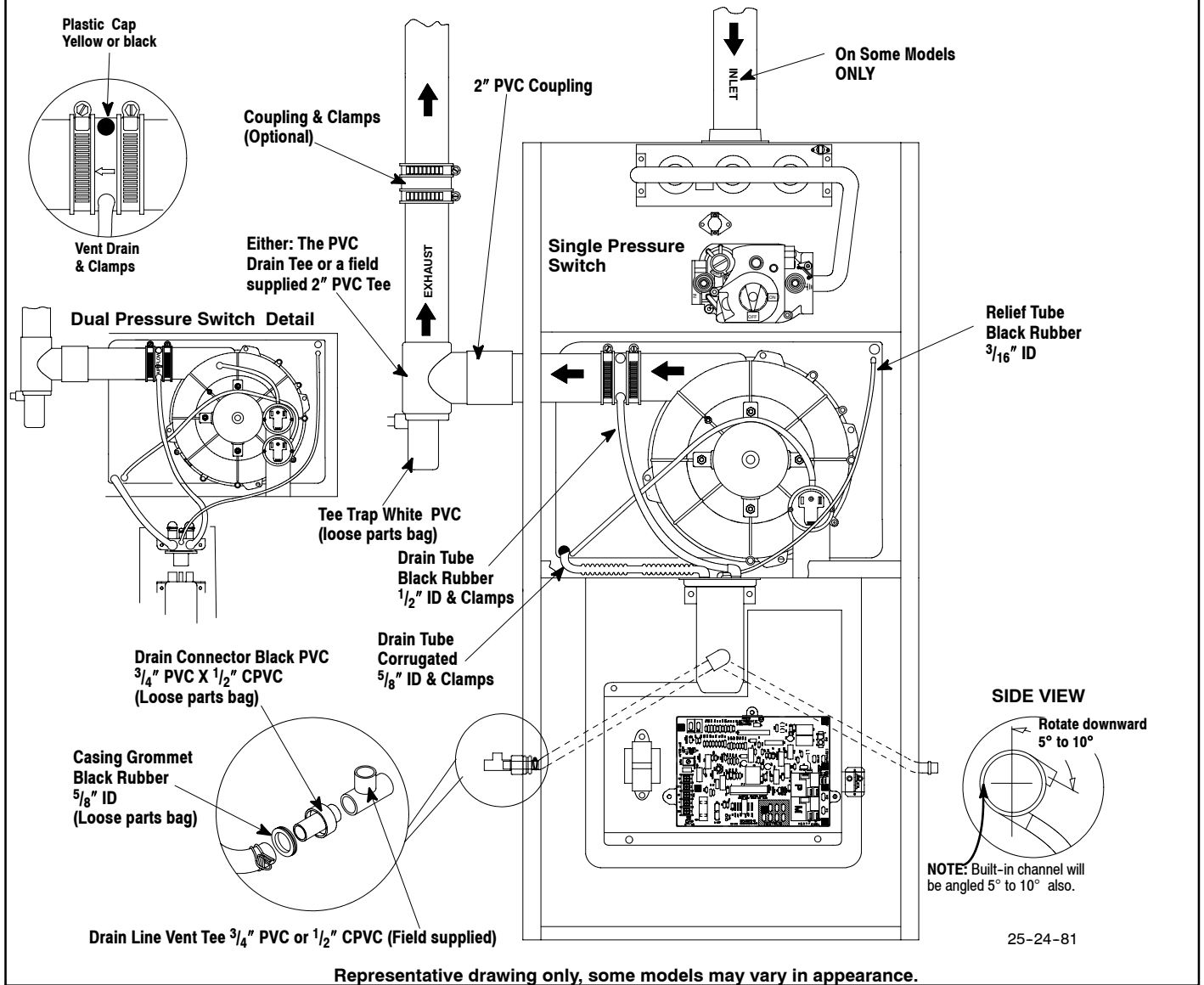

Upflow Installations Vent through Left-Side (See Figure 12)

Remove drain tee from inducer discharge and remove black drain tube (1/2" ID) from bottom of drain tee. (N9MPD and \*9MPD models only)

Install Vent Pipe grommet in side of casing.

Cut an appropriate length of 2" PVC pipe long enough to exit the cabinet and connect the vent drain to either:

- A standard field supplied 2" PVC tee (N9MP1 models), or
- A 2" PVC coupling fastened onto the drain tee (N9MPD and \*9MPD models)

Install tee trap into bottom of tee.

Remove knockout from the side of the furnace casing where drain tube will exit.

Install the 1/2" CPVC street elbow on discharge of trap

Install the black PVC drain connector (3/4" PVC x 1/2" CPVC from loose parts bag) as shown in the illustration above.

Cut the black drain tube (5/8" ID - in loose parts bag) to length to fit between trap and tube connector through grommet.

Clamp both ends of the drain tube using clamps provided.

Glue the CPVC street elbow to the trap using appropriate cleaner and solvent cement.

Connect the tee trap and the main drain line exiting the casing as shown in **Figure 20**.

**Note:** It is recommended that all PVC piping and fitting connections be fit up and inspected before final cementing. **Both the internal trap and the external tee trap must be primed before operation.** Verify all condensate drain connections are securely clamped. A coupling and clamps (in loose part bag) may be installed as shown for future servicing of the vent system.

**Figure 13**

**All Models Vent through Right-Side**

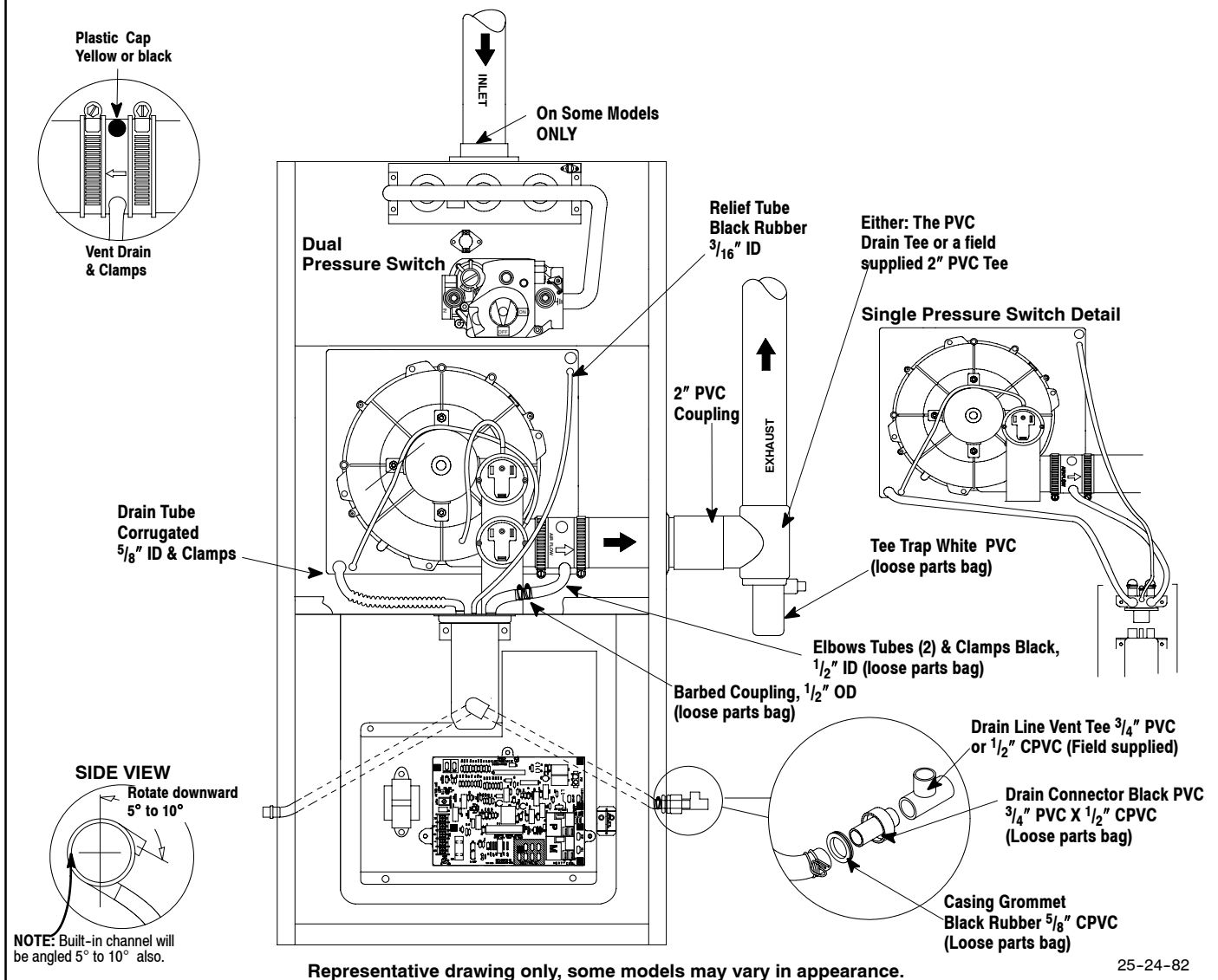

Representative drawing only, some models may vary in appearance.

25-24-82

**All Models Vent through Right-Side (See Figure 13)**

Disconnect the black drain tube between the drain vent and the trap.

Rotate the inducer 180° for a right side vent after loosening the 4 inducer attachment screws. Reinstall and retighten the inducer screws to 20" pounds torque.

Using the 1/2" OD barbed coupling in the loose parts bag connect together with the 2 short 1/2" ID elbow tubes and connect the lower discharge port of the vent drain to the trap. Secure all connections with clamps.

Install the vent pipe grommet into the casing

Cut an appropriate length of 2" PVC pipe long enough to exit the cabinet and connect the vent drain to either:

- A standard field supplied 2" PVC tee (\*9MP1 models), or
- A 2" PVC coupling fastened onto the drain tee (N9MPD and \*9MPD models)

Install tee trap into bottom section of tee.

Remove knockout from the side of the furnace casing where drain tube will exit.

Install casing grommet (black rubber 5/8" ID grommet - in loose parts bag)

Install the 1/2" CPVC street elbow on discharge of trap

Install the black PVC tube connector (3/4" PVC x 1/2" CPVC from loose parts bag) as shown in the illustration above

Cut the black drain tube (5/8" ID - in loose parts bag) to length to fit between trap and tube connector through grommet.

Clamp both ends of the drain tube using clamps provided.

Glue the CPVC street elbow to the trap using appropriate cleaner and solvent cement.

Connect the tee trap and the main drain line exiting the casing as shown in **Figure 20**.

**Note:** It is recommended that all PVC piping and fitting connections be fit up and inspected before final cementing. **Both the internal trap and the external tee trap must be primed before operation.** Verify all condensate drain connections are securely clamped. A coupling and clamps (in loose part bag) may be installed as shown for future servicing of the vent system.

Figure 14

Downflow Left-Side Vent and Trap

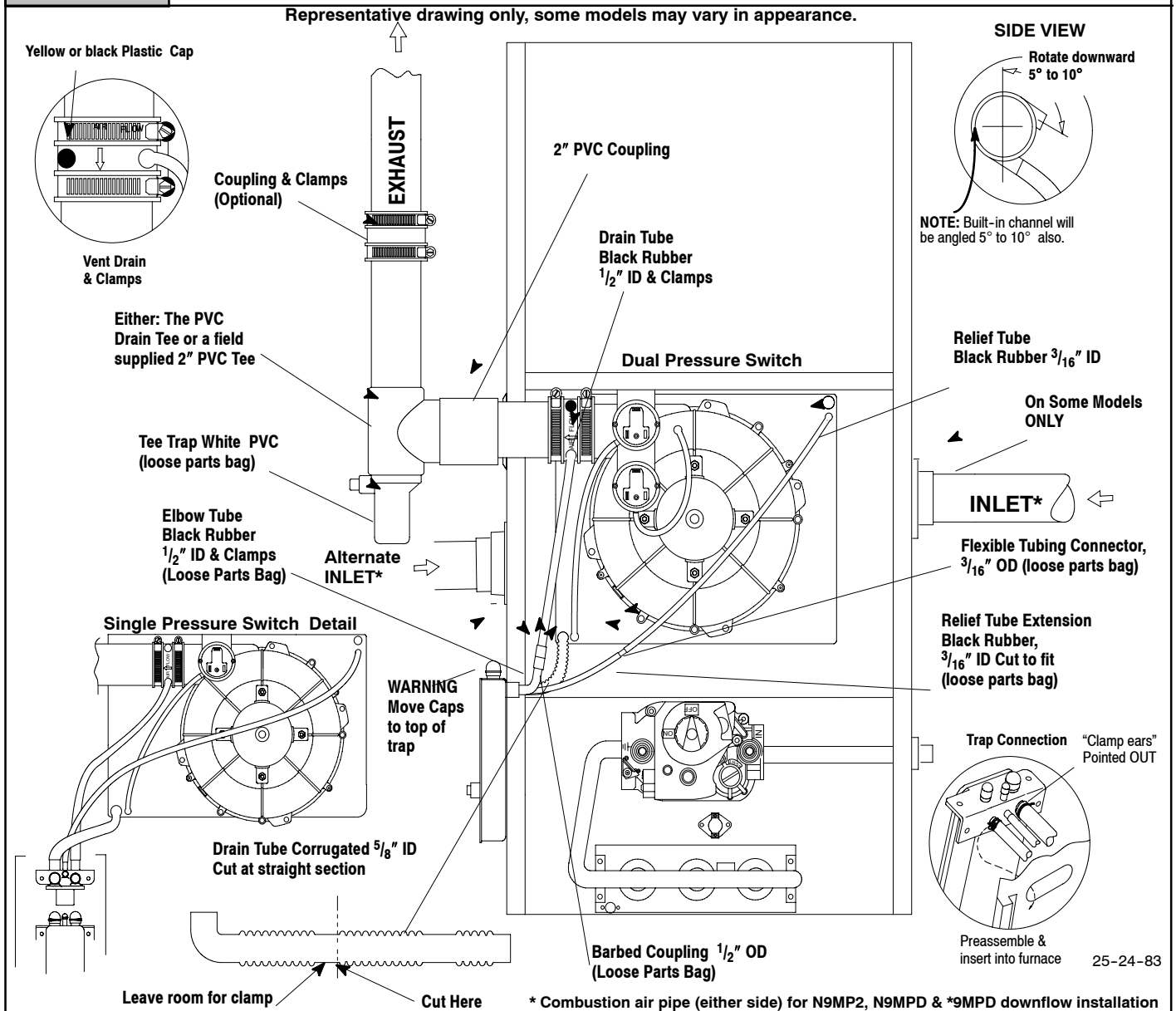

Downflow Left-Side Vent and Trap (See Figure 14)

Remove the inducer mounting screws, rotate the inducer 180° and retighten the inducer screws to 20" pounds torque.

Disconnect the hoses from the trap assembly, and remove trap and trap mounting bracket from the blower compartment. Using cover plate and gasket provided in the loose parts bag, cover the hole from the burner compartment to the blower compartment and secure with screws.

Move the caps to the top of the trap and mount the trap externally to the left side of the unit using the 2 screws provided.

Cut the 5/8" ID corrugated hose as shown above and fasten the 90° bend end to the trap and fasten the straight end to the transition drain. Secure both connections with clamps.

Reconnect the 1/2" ID drain hose from the vent drain to the trap and secure with a clamp. In some cases, additional length will be required for this hose. Use the Black plastic 1/2" OD barbed coupling and a suitable section of 1/2" ID hose to make the connection. Secure all connections with clamps

Connect the 3/16" ID relief tube from the small port on the trap to the top port of the transition as shown in the picture. In some cases, additional hose length will be needed. Use the clear plastic

3/16" OD flexible tubing connector and a suitable length of extra 3/16" ID hose to make this connection.

Install the vent pipe grommet into the casing

Cut an appropriate length of 2" PVC pipe long, enough to exit the cabinet and connect the vent drain to either:

- A standard field supplied 2" PVC tee (N9MP1), or
- A 2" PVC coupling fastened onto the drain tee (N9MPD and \*9MPD models)

Install tee trap into bottom section of tee.

Remove knockout from the side of the furnace casing where drain tube will exit.

Connect the tee trap and the main drain line exiting the casing as shown in **Figure 20**.

**Note:** It is recommended that all PVC piping and fitting connections be fit up and inspected before final cementing. **Both the external trap and the external tee trap must be primed before operation.** Verify all condensate drain connections are securely clamped. A coupling and clamps (in loose part bag) may be installed as shown for future servicing of the vent system.

**Figure 15**

**Downflow Right-Side Vent and Trap**

Representative drawing only, some models may vary in appearance.

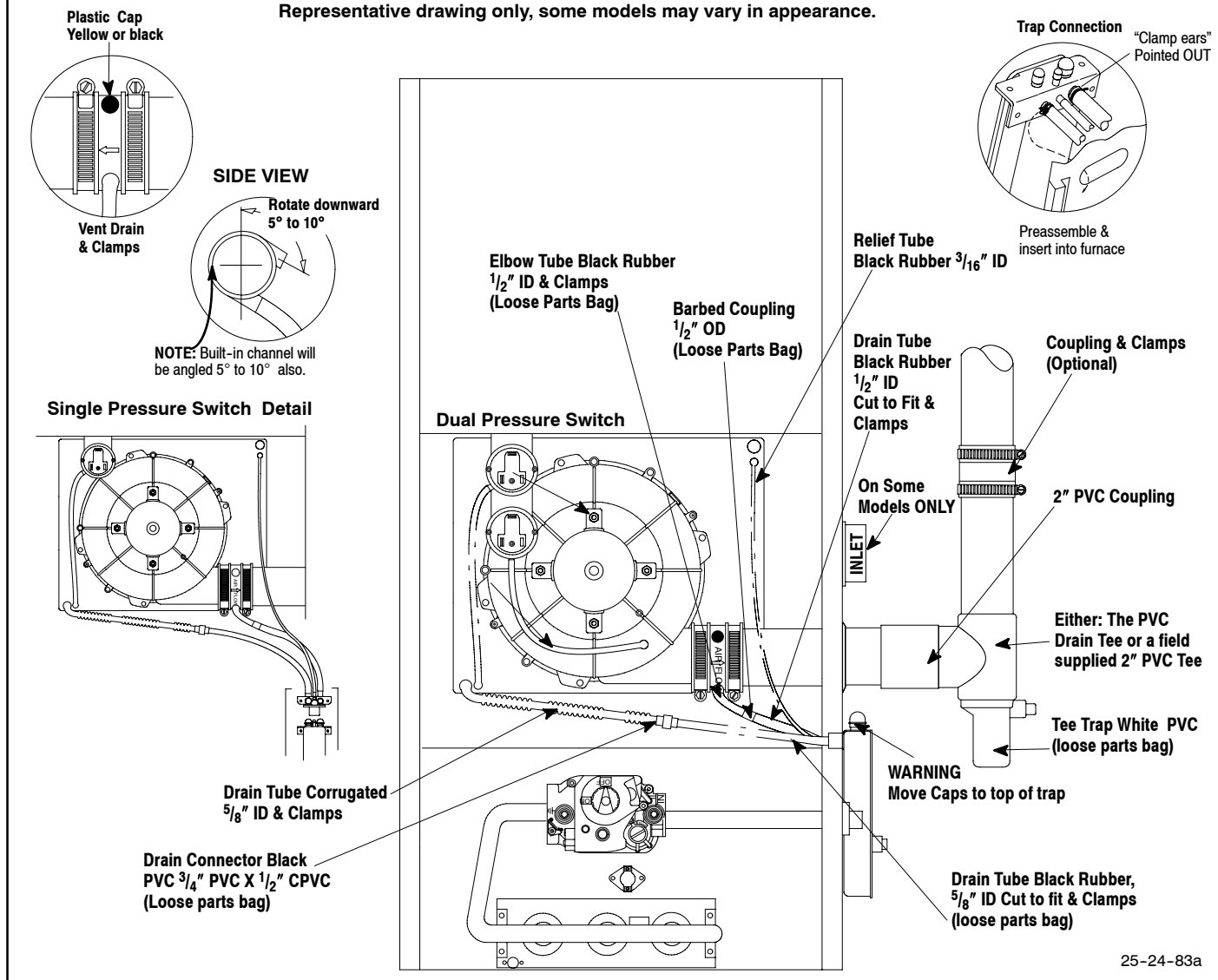

**Downflow Right-Side Vent and Trap (See Figure 15)**

Remove the drain tee if installed.

Disconnect the hoses from the trap assembly, and remove trap and trap mounting bracket from the blower compartment. Using cover plate and gasket provided in the loose parts bag, cover the hole from the burner compartment to the blower compartment and secure with screws.

Move the caps to the top of the trap and mount the trap externally to the right side of the unit using the 2 screws provided.

Connect the corrugated drain tube from the transition box to the trap as shown. If an extension is required, use the black PVC tube connector and the black 5/8" ID drain tube in the loose parts bag. Cut tube to length. Secure all connections with clamps.

Connect the drain hose from the Vent Drain to the trap. If an extension is required, use the black 1/2" OD barbed coupling, connect a black 1/2" ID elbow tube and a suitable section of a 1/2" ID drain tube to make connection from the vent drain to the trap. Secure all connections with clamps.

Install the vent pipe grommet into the casing

Cut an appropriate length of 2" PVC pipe long, enough to exit the cabinet and connect the vent drain to either:

- A standard field supplied 2" PVC tee (N9MP1 models), or
- A 2" PVC coupling fastened onto the drain tee (N9MPD and \*9MPD models)

Install tee trap into bottom section of tee.

Remove knockout from the side of the furnace casing where drain tube will exit.

Connect the tee trap and the main drain line exiting the casing as shown in **Figure 20**.

**Note:** It is recommended that all PVC piping and fitting connections be fit up and inspected before final cementing. **Both the external trap and the external tee trap must be primed before operation.** Verify all condensate drain connections are securely clamped. A coupling and clamps (in loose part bag) may be installed as shown for future servicing of the vent system.

Figure 16

Horizontal Left through Top

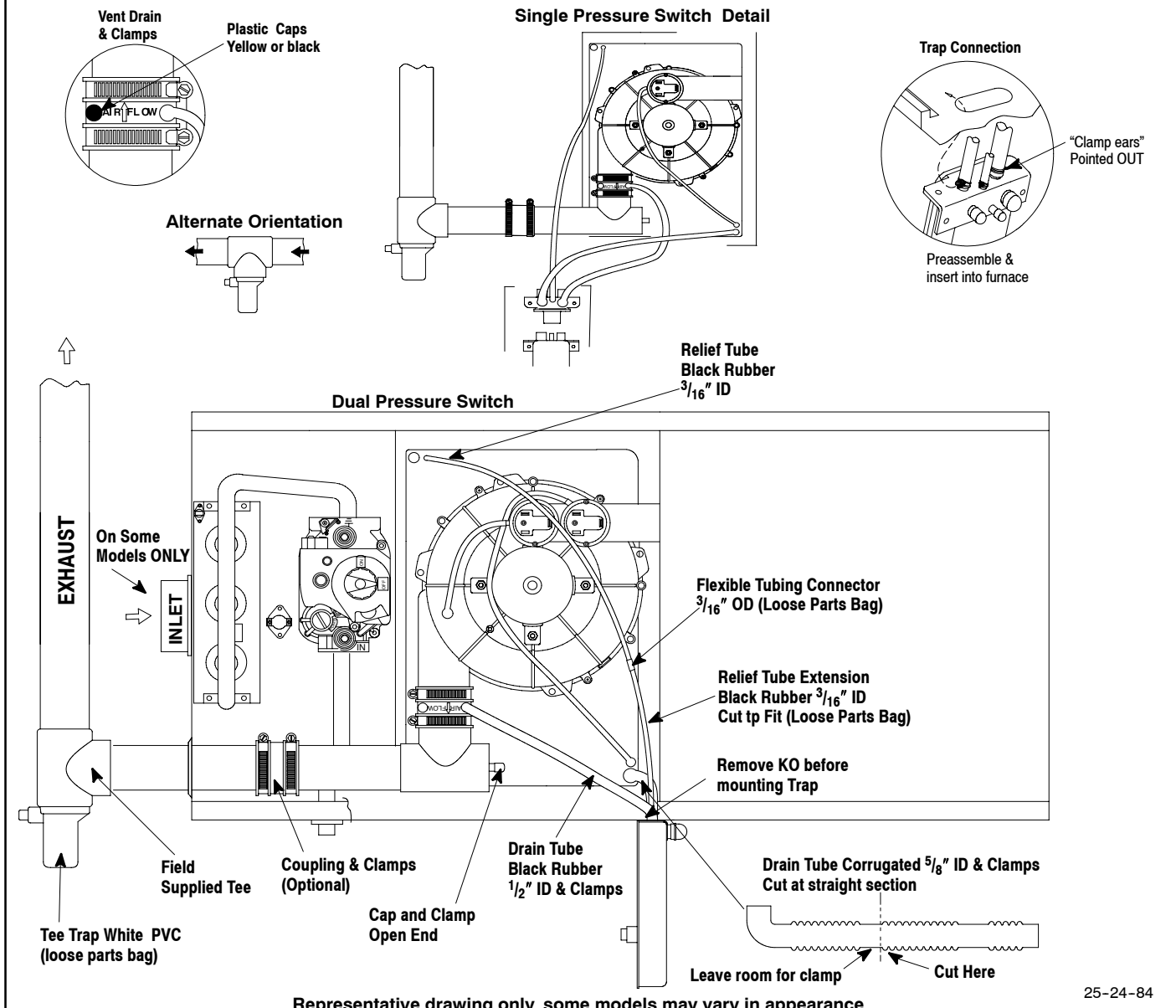

25-24-84

**Horizontal Left through Top (See Figure 16)**

Disconnect the hoses from the trap assembly, and remove trap and trap mounting bracket from the blower compartment. Using cover plate and gasket provided in the loose parts bag, cover the hole from the burner compartment to the blower compartment and secure with screws.

Remove knockout from the side of the furnace casing where drain tube will exit.

Mount the trap externally to the bottom side of the unit using the 2 screws provided in the location shown.

Cut the corrugated tube as shown in the illustration above. Connect the corrugated hose from the transition to the trap. Secure connections with clamps.

Remove the black 1/2" ID drain tube from the drain tee. Install a yellow cap and clamp over the open drain port of the drain tee.

Connect the black 1/2" ID drain tube from the Vent Drain to the trap. Secure connections with clamps.

Connect the 3/16" ID relief tube to the middle port on the trap. If an extension is required, use the 3/16" OD flexible tubing connector and the black 3/16" ID relief tube in the loose parts bag. Cut tube to length. Secure all connections with clamps.

Cut an appropriate length of 2" PVC pipe, long enough to exit the cabinet and connect the vent drain to either:

- A standard field supplied 2" PVC tee (N9MP1 models), or
- A 2" PVC coupling fastened onto the drain tee (N9MPD and \*9MPD models)

Install tee trap into bottom section of tee.

Connect the tee trap and the main drain line exiting the casing as shown in **Figure 20**.

**Note:** It is recommended that all PVC piping and fitting connections be fit up and inspected before final cementing. **Both the external trap and the external tee trap must be primed before operation.** Verify all condensate drain connections are securely clamped. A coupling and clamps (in loose part bag) may be installed as shown for future servicing of the vent system.

Figure 17

## Horizontal Left-Side Vent

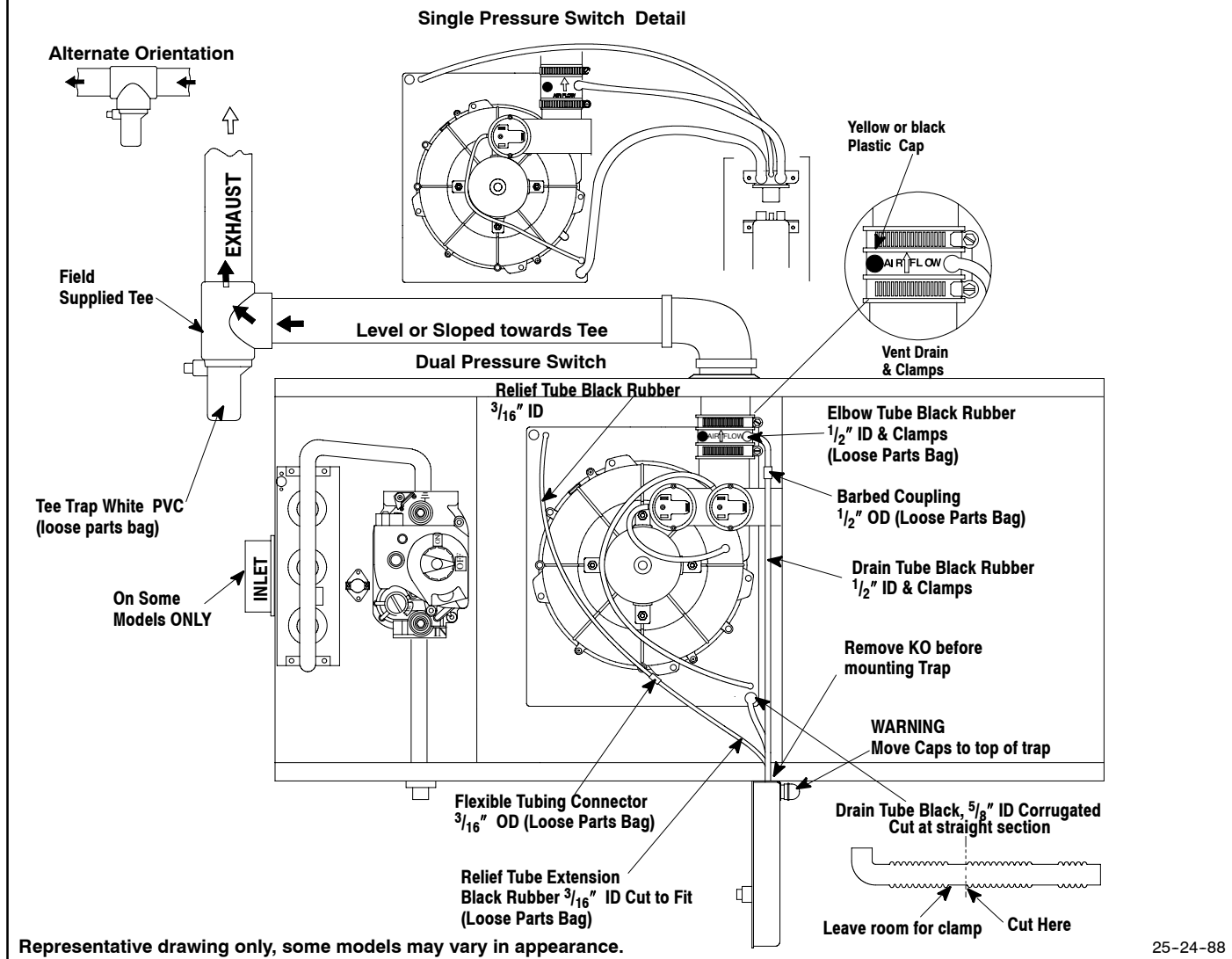

25-24-88

### Horizontal Left-Side Vent (See Figure 17)

Remove the drain tee from the Vent Drain if installed (N9MPD and \*9MPD models only)

Rotate the inducer 180° for a side vent after loosening the 4 inducer attachment screws. Reinstall and retighten the inducer screws to 20" pounds torque.

Disconnect the hoses from the trap assembly, and remove trap and trap mounting bracket from the blower compartment. Using cover plate and gasket provided in the loose parts bag, cover the hole from the burner compartment to the blower compartment and secure with screws.

Remove knockout from the side of the furnace casing where drain tube will exit.

Mount the trap externally to the bottom side of the unit using the 2 screws provided in the location shown.

Cut the corrugated tube as shown in the illustration above. Connect the corrugated hose from the transition to the trap. Secure connections with clamps.

Connect the black 1/2" ID drain tube from the Vent Drain to the trap. If an extension is required, use the black 1/2" OD flexible tubing connector and the black 1/2" ID drain tube in the loose parts bag. Cut tube to length. Secure connections with clamps.

Connect the 3/16" ID relief tube to the middle port on the trap. If an extension is required, use the 3/16" OD flexible tubing connector and the black 3/16" ID relief tube in the loose parts bag. Cut tube to length.

Cut an appropriate length of 2" PVC pipe, fittings and extension pipe long enough to exit the cabinet and connect the vent drain to either:

- A standard field supplied 2" PVC tee (N9MP1 models), or
- A 2" PVC coupling fastened onto the drain tee (N9MPD and \*9MPD models)

Install tee trap into bottom section of tee.

Important: The pipe to the tee trap must be level or sloping towards the tee trap

Connect the tee trap and the main drain line exiting the casing as shown in **Figure 20**.

**Note:** It is recommended that all PVC piping and fitting connections be fit up and inspected before final cementing. **Both the external trap and the external tee trap must be primed before operation.** Verify all condensate drain connections are securely clamped. A coupling and clamps (in loose part bag) may be installed as shown for future servicing of the vent system.



**Figure 18**

**Horizontal Right through Top**

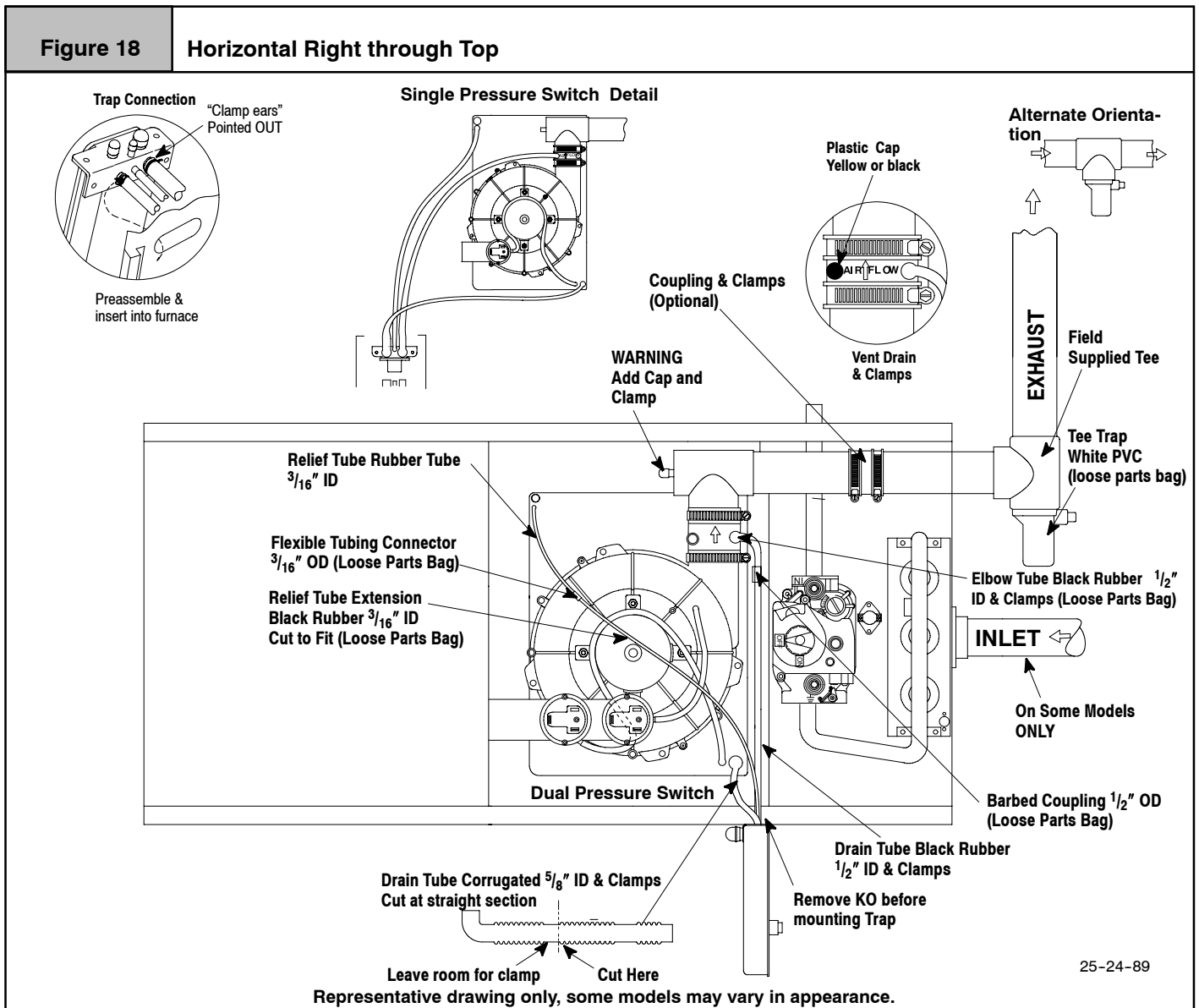

**Horizontal Right through Top (See Figure 18)**

Disconnect the hoses from the trap assembly, and remove trap and trap mounting bracket from the blower compartment. Using cover plate and gasket provided in the loose parts bag, cover the hole from the burner compartment to the blower compartment and secure with screws.

Remove knockout from the side of the furnace casing where drain tube will exit.

Mount the trap externally to the bottom side of the unit using the 2 screws provided in the location shown.

Cut the corrugated tube as shown in the illustration above. Connect the corrugated hose from the transition to the trap. Secure connections with clamps.

Connect the black 1/2" ID drain tube from the Vent Drain to the trap. If an extension is required, use the black 1/2" OD barbed coupling and the black 1/2" ID drain tube in the loose parts bag. Cut tube to length. Secure connections with clamps.

Connect the 3/16" ID relief tube to the middle port on the trap. If an extension is required, use the clear 3/16" OD flexible tubing connector and the black 3/16" ID relief tube in the loose parts bag. Cut tube to length.

Cut an appropriate length of 2" PVC pipe, fittings and extension pipe long enough to exit the cabinet and connect the vent drain to a standard field supplied 2" PVC tee

Install tee trap into bottom section of tee.

Connect the tee trap and the main drain line exiting the casing as shown in **Figure 20**.

**Note:** It is recommended that all PVC piping and fitting connections be fit up and inspected before final cementing. **Both the external trap and the external tee trap must be primed before operation.** Verify all condensate drain connections are securely clamped. A coupling and clamps (in loose part bag) may be installed as shown for future servicing of the vent system.

Figure 19

Horizontal Right-Side Vent

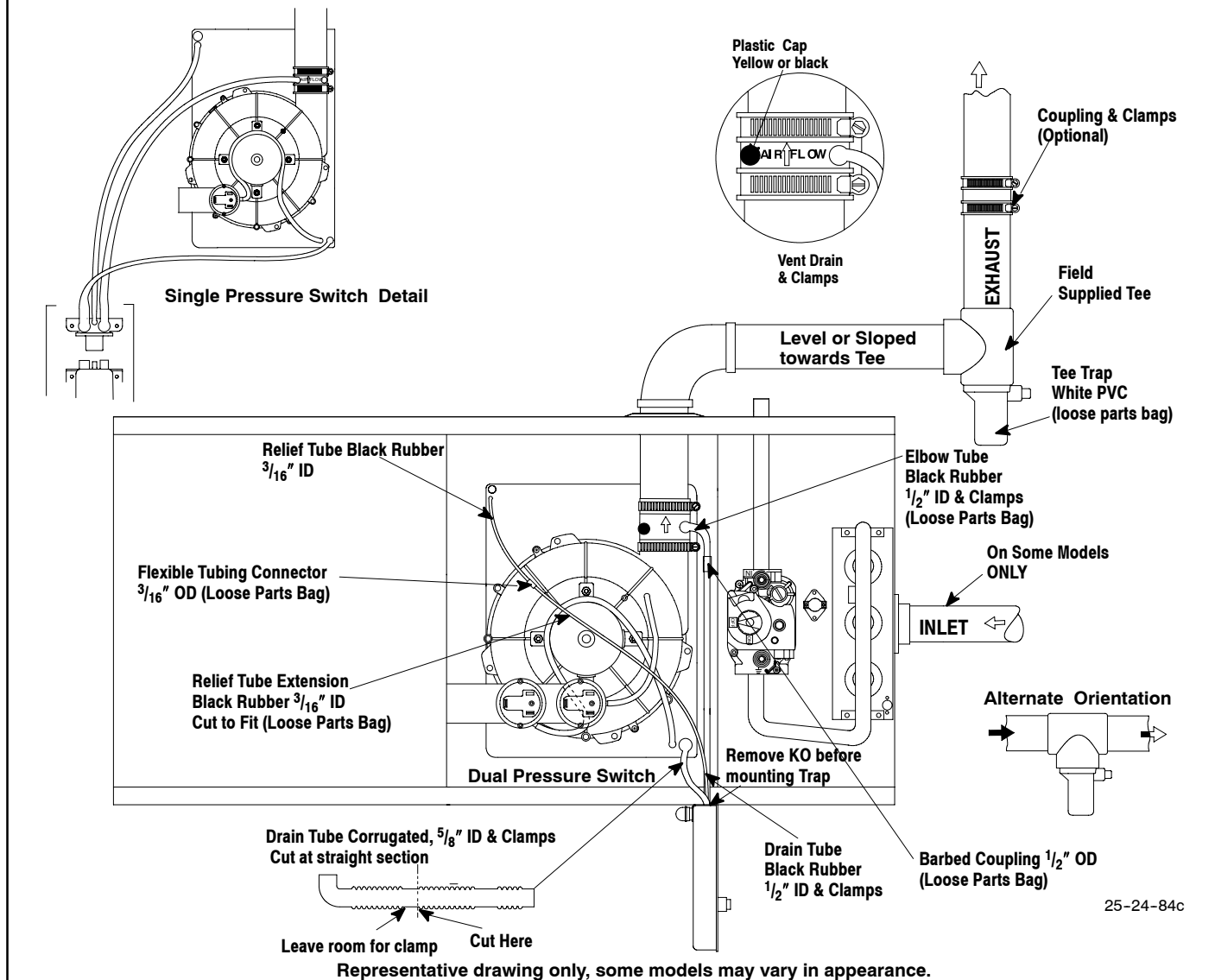

Horizontal Right-Side Vent (See Figure 19)

Disconnect drain tee if installed (N9MPD and \*9MPD models only)

Disconnect the hoses from the trap assembly, and remove trap and trap mounting bracket from the blower compartment. Using cover plate and gasket provided in the loose parts bag, cover the hole from the burner compartment to the blower compartment and secure with screws.

Remove knockout from the side of the furnace casing where drain tube will exit.

Mount the trap externally to the bottom side of the unit using the 2 screws provided in the location shown.

Cut the corrugated tube as shown in the illustration above. Connect the corrugated hose from the transition to the trap. Secure connections with clamps.

Connect the black 1/2" ID drain tube from the Vent Drain to the trap. If an extension is required, use the 1/2" OD barbed coupling and the black 1/2" ID drain tube in the loose parts bag. Cut tube to length. Secure connections with clamps.

Connect the 3/16" ID relief tube to the middle port on the trap. If an extension is required, use the clear 3/16" OD splice connector and

the black 3/16" ID relief tube in the loose parts bag. Cut tube to length.

Cut an appropriate length of 2" PVC pipe, fittings and extension pipe long enough to exit the cabinet and connect the vent drain to either:

- A standard field supplied 2" PVC tee (N9MP1 models), or
- A 2" PVC coupling fastened onto the drain tee (N9MPD and \*9MPD models)

Install tee trap into bottom section of tee.

Important: The pipe to the tee trap must be level or sloping towards the tee trap

Connect the tee trap and the main drain line exiting the casing as shown in Figure 20.

**Note:** It is recommended that all PVC piping and fitting connections be fit up and inspected before final cementing. **Both the external trap and the external tee trap must be primed before operation.** Verify all condensate drain connections are securely clamped. A coupling and clamps (in loose part bag) may be installed as shown for future servicing of the vent system.

Figure 20

**Connecting Tee Trap to Condensate Trap and Main Drain Line**

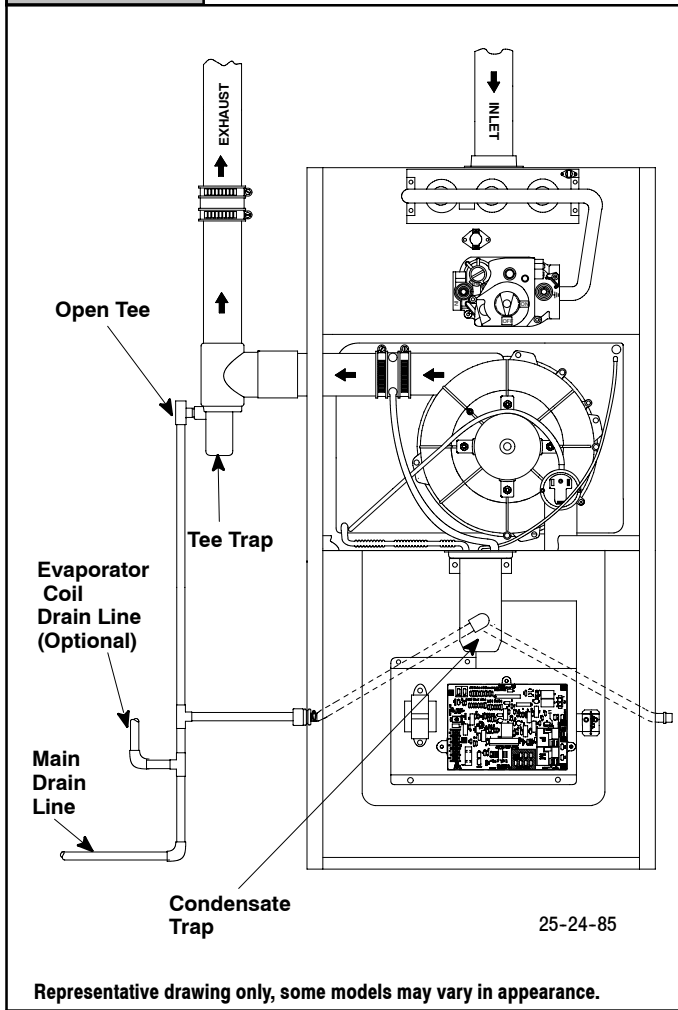

The tee trap must be connected to the main condensate drain line as conceptually shown above. Different installations may require slightly different orientations. The following steps apply to all installations.

1. The tee trap should be installed as close to the side or top of the furnace as practical. Minimize the distance between the inducer and the tee trap as much as possible.
2. An open tee is to be used at the tee trap discharge. The top end of the tee should be open to the atmosphere to eliminate potential air lock problems.
3. The drain line from the tee trap is to be connected to the furnace condensate trap drain line as shown above.
4. Condensate drain lines from a cooling coil may be connected downstream of the connection point of the tee trap and furnace condensate trap.

**Important: Prime both traps with water before operation.** Failure to prime the traps may result in discharge of flue gases from the condensate drain line and open tee for a period of time, and may result in temporary lockout of the furnace upon start up. Main drain line construction is left to the discretion of the installer. It may be made of either ridged pipe or flexible tube. Tube ID should NOT be less than 1/2".

**Connecting Vent and Combustion Air Piping**

⚠ WARNING

CARBON MONOXIDE POISONING HAZARD.

Failure to follow this warning could result in personal injury or death.

Cement or mechanically seal all joints, fittings, etc. to prevent leakage of flue gases.

Refer to **Figure 11** through **Figure 19** that corresponds to the installation position of the furnace for the application.

Preassemble the vent and combustion air piping from the furnace to the vent termination. Do not cement the pipe joints until the pipe preassembly process is complete.

**Combustion Air Pipe Connection (Dual Certified or Direct Vent)**

Install the air intake coupling and gasket to the furnace with the four(4) screws.

Note: The air intake coupling and gasket can be installed to the top panel to the alternate air intake locations on either the left or right side panels of the furnace.

For downflow installation, the air intake coupling and gasket must be installed to the alternate air intake location on either the left or right side panels. Remove the 3" hole plug from the side panel and relocate to the air intake hole in the top panel. Use four screws to seal the four(4) mounting holes in the top panel next to the hole plug. Drill four(4) 7/64" diameter holes in the casing using the air intake coupling as the template.

The air intake coupling is sized for 2" PVC pipe.

Install the combustion air pipe to the air intake coupling using RTV sealant to provide for future serviceability.

**Vent Pipe Connection**

Install the vent pipe grommet to the furnace panel. Locate the grommet in the furnace panel at a location directly away from the vent fitting on the combustion blower. The grommet snaps into the 3" hole plug from the furnace panel. NOTE: Depending on the installation position, the vent pipe grommet will be installed to the top panel or to the alternate location on the side panels. If needed, remove the 3" hole plug from the furnace panel and relocate to the open hole in the furnace panel. (See **Figure 11** or **Figure 20**)

Install the vent pipe to the rubber coupling, the vent fitting or the PVC vent extension pipe. Securely attach using the clamp or PVC cement as required.

**Note: The vent fitting MUST be installed with the air flow marking arrow pointed toward the vent pipe. (See Figure 21) Some installations require the vent fitting to be installed with a 5° to 10° downward slope. (See Figure 11 through Figure 20)**

**Figure 21**

**Proper Sealing Procedure for Combustion Blower**

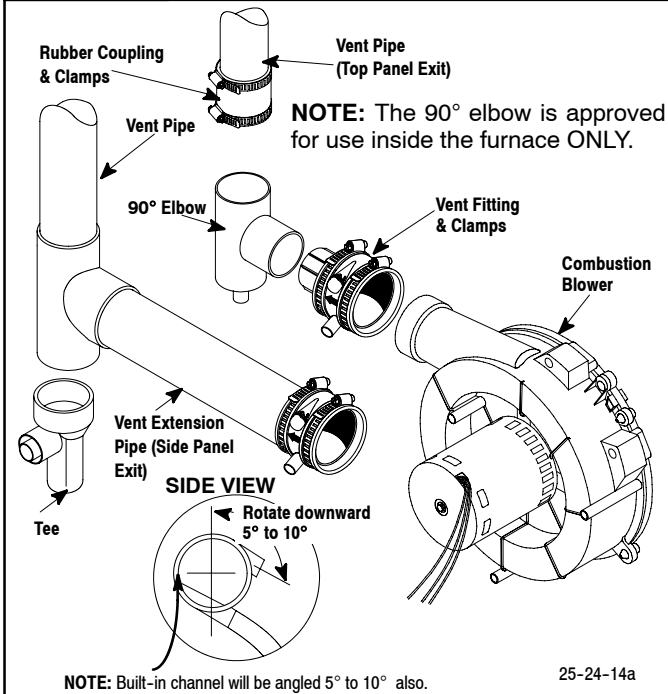

2. After checking pipe and socket for proper fit, wipe socket and pipe with cleaner-primer. Apply a liberal coat of primer to inside surface of socket and outside of pipe. Do **NOT** allow primer to dry before applying cement.
3. Apply a thin coat of cement evenly in the socket. Quickly apply a heavy coat of cement to the pipe end and insert pipe into fittings with a slight twisting movement until it bottoms out.

**NOTE:** Cement **MUST** be fluid while inserting pipe. If **NOT**, recoat pipe.

4. Hold the pipe in the fitting for 30 seconds to prevent the tapered socket from pushing the pipe out of the fitting.
5. Wipe all excess cement from the joint with a rag. Allow 15 minutes before handling. Cure time varies according to fit, temperature and humidity.

**Connecting Vent Pipes and Termination**

**NOTE:** Combustion air intake and vent **MUST** terminate in the same atmospheric pressure zone. If installation is in a cold climate (sustained temperatures 0°F (-18°C) and below for 24 or more consecutive hours), increase the minimum distance between vent pipe and air intake from 8" to 18".

**! WARNING**

**CARBON MONOXIDE POISONING HAZARD.**  
 Failure to follow this warning could result in personal injury or death.  
 Maintain a minimum of 36" between combustion air inlet and clothes dryer vent. Terminate the combustion air intake as far as possible from any air conditioner, heat pump, swimming pool, swimming pool pumping, chlorinator or filtration unit.

**Joining Pipe and Fittings**

SEE VENT AND COMBUSTION AIR PIPING, Vent and Combustion Air Piping Guidelines in this manual for applicable ASTM Standards for vent materials.

**! WARNING**

**FIRE HAZARD.**  
 Failure to follow this warning could result in personal injury, death and/or property damage. Observe all cautions and warnings printed on material containers  
 Provide adequate ventilation and do **NOT** assemble near heat source or open flame. Do **NOT** smoke while using solvent cements and avoid contact with skin or eyes.

**! WARNING**

**CARBON MONOXIDE POISONING HAZARD.**  
 Failure to follow this warning could result in personal injury or death.  
 Do **NOT** use solvent cement that has become curdled, lumpy or thickened and do **NOT** thin. Observe precautions printed on containers. For applications below 32° F., use only low temperature type solvent cement. Poor joints may lead to disconnected or leaking vent pipe joints allowing carbon monoxide to enter the living space.

1. Cut pipe end square, remove ragged edges and burrs. Chamfer end of pipe, then clean fitting, socket and pipe joint of all dirt, grease, or moisture.

**NOTE:** Stir the solvent cement frequently while using. Use a natural bristle brush or the dauber supplied with the cement. The proper brush size is one inch.

1. Install all couplings, nipples and elbows using proper procedures for **Joining Pipe and Fittings** and maintain spacing between vent and combustion air piping as indicated in **Figure 22** through **Figure 30**.

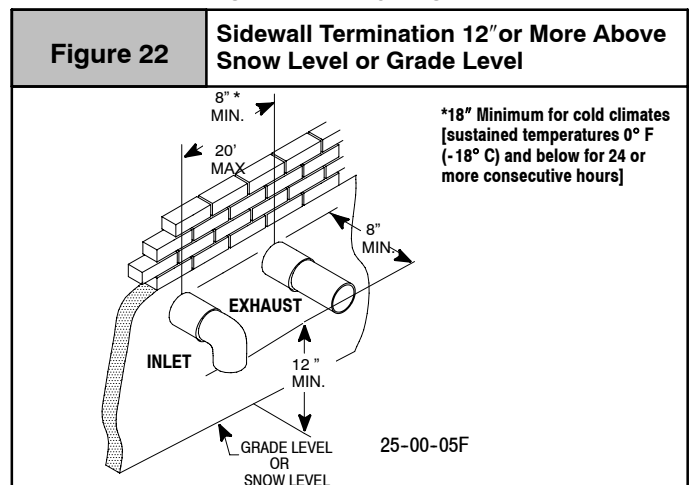

**Horizontal Termination**

1. Cut two holes. 2 1/2" for 2" pipe, 3" for 2 1/2" pipe, or 3 1/2" for 3" pipe. Do **NOT** make the holes oversized, or it will be necessary to add a sheet metal or plywood plate on the outside with the correct size hole in it.
2. Check hole sizes by making sure it is smaller than the couplings or elbows that will be installed on the outside. The couplings or elbows **MUST** prevent the pipe from being pushed back through the wall.

3. Extend vent pipe and combustion air pipe through the wall  $\frac{3}{4}$ " to 1" and seal area between pipe and wall.
4. Install the couplings, nipple and termination elbows as shown and maintain spacing between vent and combustion air piping as indicated in **Figure 22** and **Figure 23**.

A metal shield is recommended 18" x 18" min. or 18" min. diameter around the vent termination at the exterior wall to protect the house exterior materials from flue product or condensation (freezing) damage.

## Using Exterior Risers

1. Install elbows and pipe to form riser as shown in **Figure 23**.
2. Secure vent pipe to wall with galvanized strap or other rust resistant material to restrain pipe from moving.
3. Insulate pipe with Armaflex or equivalent moisture resistant closed cell foam insulation or Fiberglass insulation if boxed in and sealed against moisture.

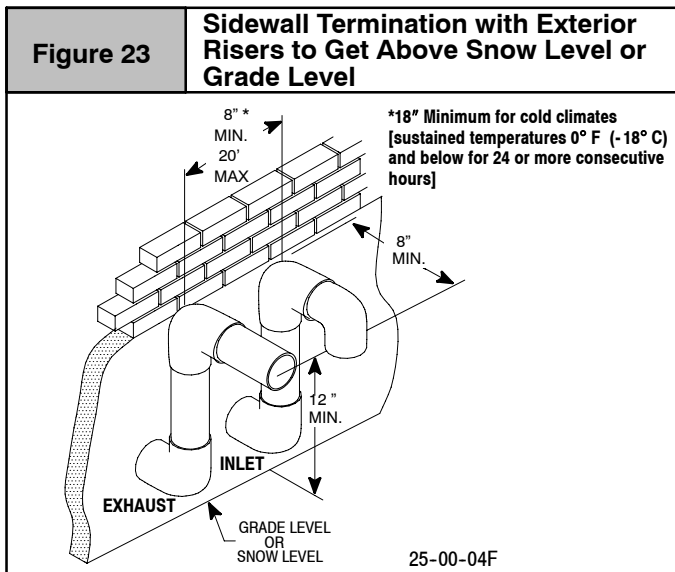

## Vertical Termination

1. **Figure 24** shows the proper installation and clearances for vertical vent termination. The vertical roof termination should be sealed with a plumbing roof boot or equivalent flashing. The inlet of the intake pipe and end of the exhaust vent must be terminated no less than 12" above the roof or snow accumulation level, and 12" away from a vertical wall or other protrusion.
2. If the vent system is installed in an existing chimney make sure clearances shown in **Figure 24** are maintained. Horizontal section before the termination elbow can be extended on the inlet air to provide necessary clearance.

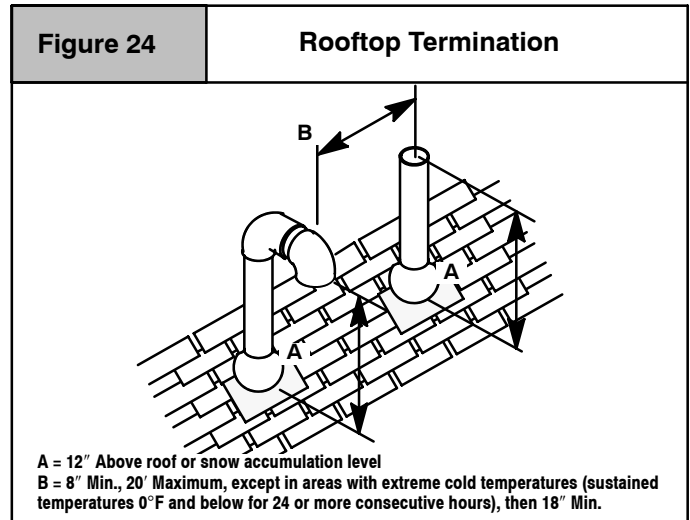

## Vent Termination Shielding

Under certain wind conditions some building materials may be affected by flue products expelled in close proximity to unprotected surfaces. Sealing or shielding of the exposed surfaces with a corrosion resistant material (such as aluminum sheeting) may be required to prevent staining or deterioration. The protective material should be attached and sealed (if necessary) to the building before attaching the vent terminal.

## Multi Vent Termination Clearances

When two (2) or more furnaces are vented near each other, each furnace must be individually vented.

Two (2) vent terminations may be installed as shown in **Figure 25**, **Figure 26**, **Figure 27**, **Figure 28**, **Figure 29** and **Figure 30**, but the next vent termination must be at least 36" away from first 2 terminations. It is important that vent terminations be made as shown to avoid recirculation of flue gases.

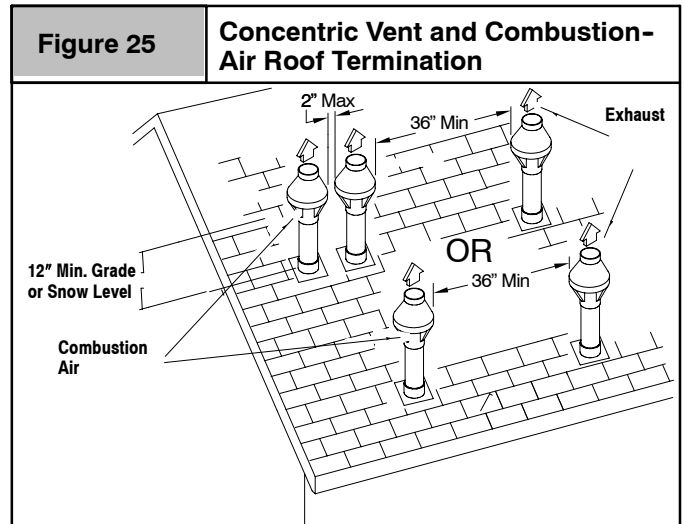

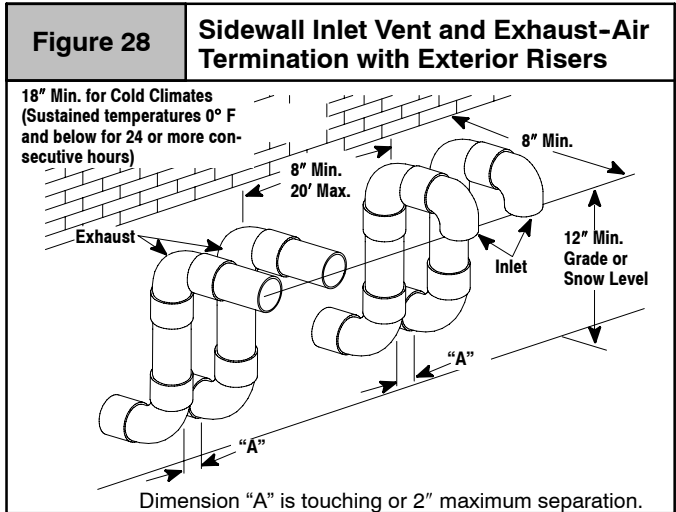
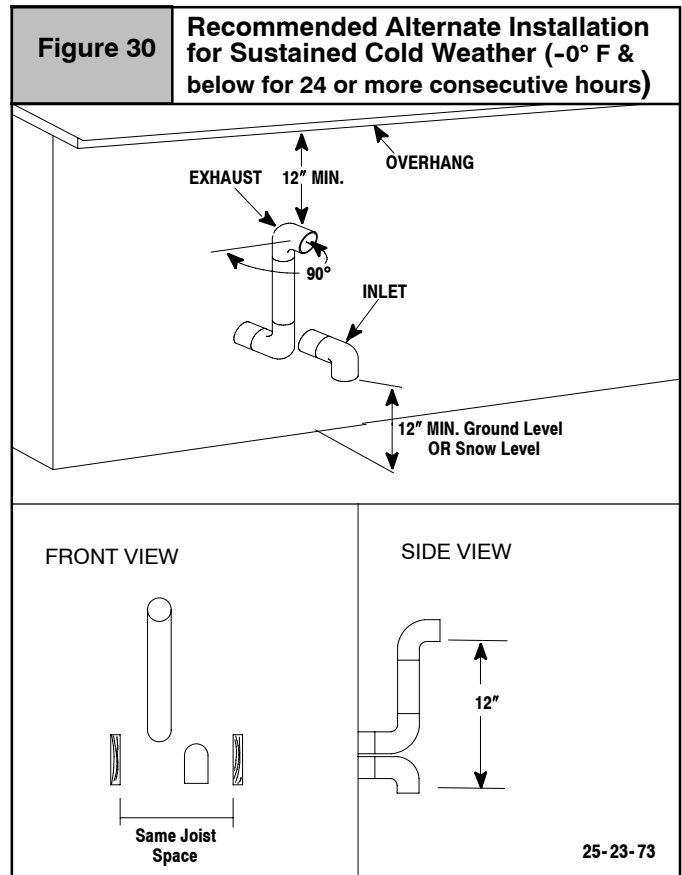
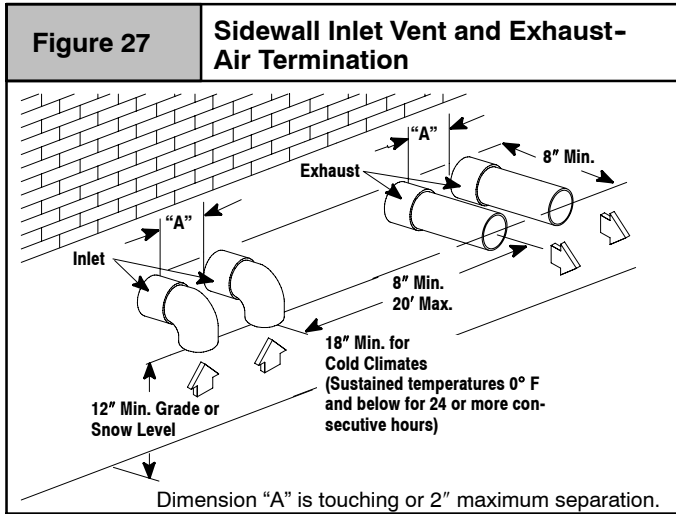
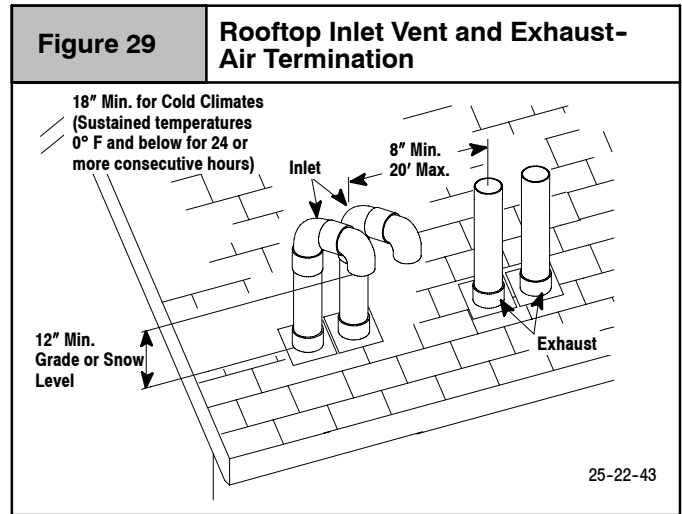
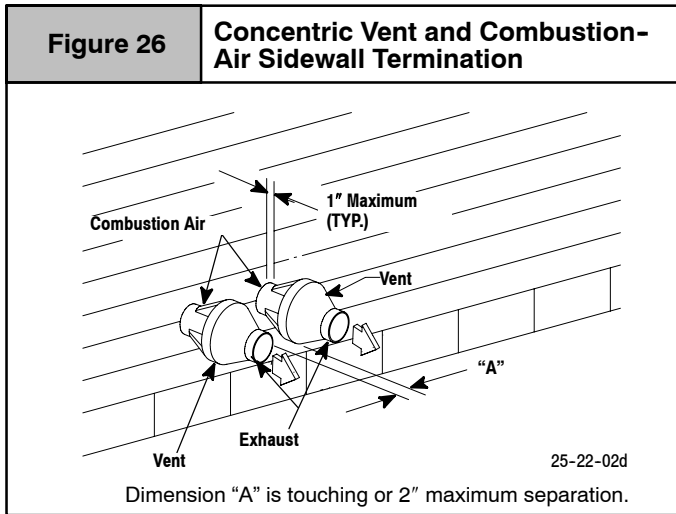

## 5. Concentric Termination

**⚠ WARNING**

**CARBON MONOXIDE POISONING, FIRE AND EXPLOSION HAZARD.**

Failure to follow this warning could result in personal injury, death and/or property damage. Inlet and outlet pipes may NOT be vented directly above each other (standard vent terminals).

## Vent Termination Clearances

1. Determine termination locations based on clearances specified in following steps and as shown in **Figure 8**, **Figure 31** through **Figure 36**.
2. The vent termination must be located at least 12" above ground or normally expected snow accumulation levels.

- Do **NOT** terminate over public walkways. Avoid areas where condensate may cause problems such as above planters, patios, or adjacent to windows where steam may cause fogging.
- The vent termination shall be located at least 4' horizontally from any electric meter, gas meter, gas regulator, and any relief equipment. These distances apply **ONLY** to U.S. installations.
- The vent termination is to be located at least 3' above any forced air inlet located within 10'; and at least 10' from a combustion air intake of another appliance, except another direct vent furnace intake.
- In Canada, the *Canadian Fuel Gas Code* takes precedence over the preceding termination instructions.

## Concentric Vent Termination Kit # NAHA001CV & NAHA002CV

For Concentric Vent Termination information call 931.270.4100 with the complete model and serial number of the furnace.

These kits are for vertical or horizontal termination of the combustion air inlet and the exhaust vent pipes on Category IV gas-fired condensing furnaces. The NAHA001CV kit can be used for 3" diameter pipe systems. The NAHA002CV kit can be used for 2" diameter pipe system. Refer to **Table 5** for the correct pipe size for the furnace. Both the combustion air inlet and the exhaust vent pipes must attach to the termination kit. The termination kit must terminate outside the structure and must be installed per the instructions outlined below for vertical or horizontal termination. Vertical termination is preferred. Field supplied pipe and fittings are required to complete the installation.

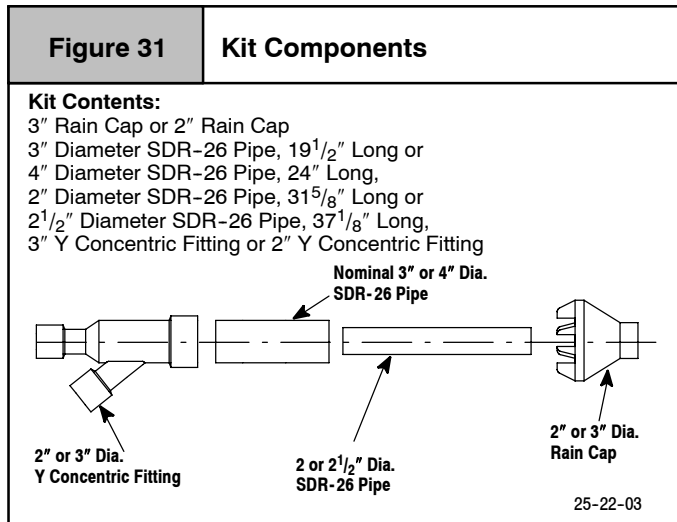

### Vertical & Horizontal Termination

- Determine the pipe diameters required for the installation from **Table 5** and **Figure 33**.
- Determine the best location for the termination kit. See **Figure 32** for vertical termination or **Figure 36** for horizontal termination. Roof termination is preferred since it is less susceptible to damage, has reduced intake contaminants and less visible vent vapor. For side wall termination, consideration should be given to: 1) possible damage from the vapors to plants/shrubs, other equipment and building materials, 2) possible damage to the terminal from foreign objects, 3) wind effects that may cause recirculation of flue products, debris or light snow and 4) visible vent vapor.

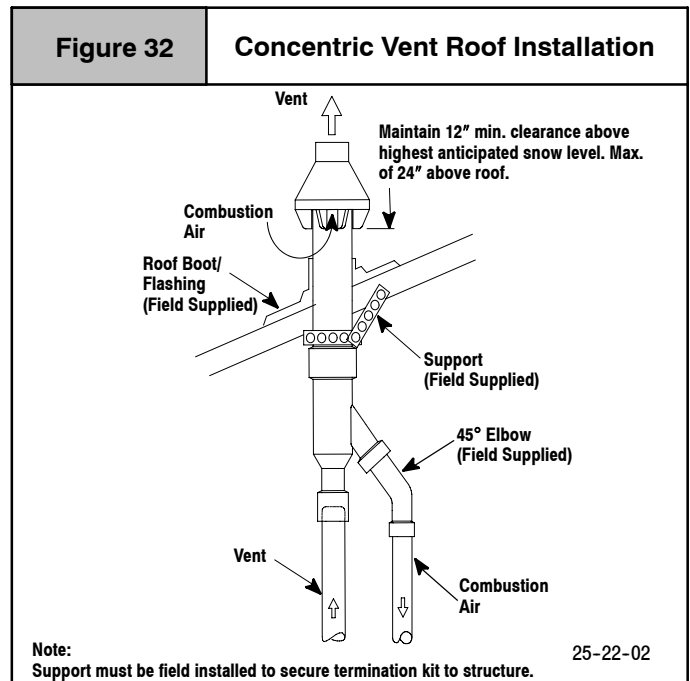

- Cut one 5" diameter hole through the structure for the NAHA001CV Kit or one 4" diameter hole for the NAHA002CV Kit .
- Dimension D may be lengthened to 60" max. or shortened by cutting the pipes to 12" min. Dimension A will change according to D dimension. (See **Figure 33**)

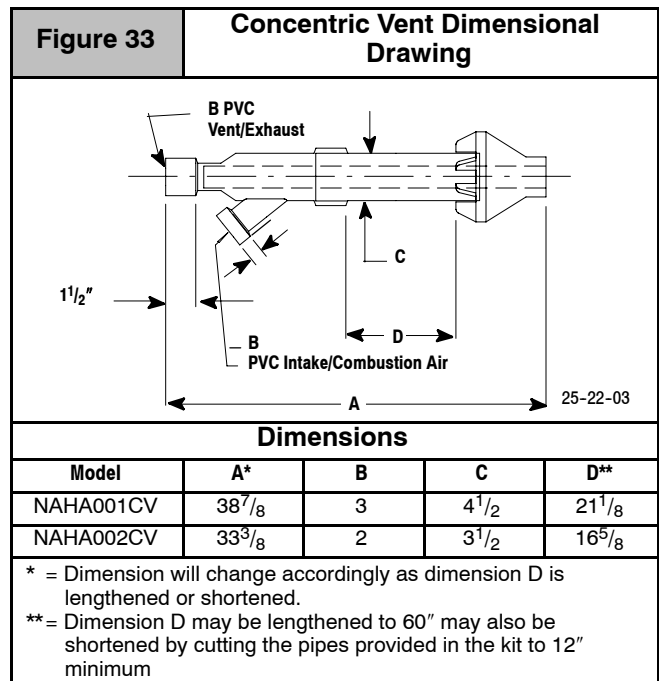

Table 5	Concentric Termination Kit NAHA001CV & NAHA002CV Venting Table for N9MPD & *9MPD Models
40,000, 50,000, 60,000, 75,000 & 80,000 Btuh Furnaces	
NAHA002CV - 35' & (4) 90° elbows with 2" PVC pipe or NAHA001CV - 65' & (4) 90° elbows with 3" PVC pipe	
100,000 Btuh Furnace	
NAHA001CV - 35' & (4) 90° elbows with 3" PVC pipe or NAHA001CV - 65' & (4) 90° elbows with 3" PVC pipe & Long Vent Kit (see Tech. Manual).	
125,000 Btuh Furnace	
NAHA001CV - 35' & (4) 90° elbows with 3" PVC pipe	
<ol style="list-style-type: none"> <li>1. Do not include the field supplied 45° elbow in the total elbow count.</li> <li>2. If more than four elbows are required, reduce the length of both the inlet and the exhaust pipes five feet for each additional elbow used.</li> <li>3. Elbows are DWV long radius type for 2" and 3" vents.</li> </ol> <p>NOTE: Feet of pipe is whichever pipe run is the longest, either inlet or outlet side.</p>	

Table 6	Concentric Termination Kit NAHA001CV & NAHA002CV Venting Table for N9MP2 Models
50,000 & 80,000 Btuh Furnaces	
NAHA002CV - 35' & (4) 90° elbows with 2" PVC pipe or NAHA001CV - 65' & (4) 90° elbows with 3" PVC pipe	
75,000 Btuh Furnaces	
NAHA002CV - 20' & (2) 90° elbows with 2" PVC pipe or NAHA002CV - 35' & (4) 90° elbows with 2" PVC pipe or Long Vent Kit (See Tech. Manual) or NAHA001CV - 65' & (4) 90° elbows with 3" PVC pipe	
100,000 Btuh Furnace	
NAHA001CV - 35' & (4) 90° elbows with 3" PVC pipe or NAHA001CV - 65' & (4) 90° elbows with 3" PVC pipe & Long Vent Kit (see Tech. Manual).	
125,000 Btuh Furnace	
NAHA001CV - 35' & (4) 90° elbows with 3" PVC pipe	
<ol style="list-style-type: none"> <li>1. Do not include the field supplied 45° elbow in the total elbow count.</li> <li>2. If more than four elbows are required, reduce the length of both the inlet and the exhaust pipes five feet for each additional elbow used.</li> <li>3. Elbows are DWV long radius type for 2" and 3" vents.</li> </ol> <p>NOTE: Feet of pipe is whichever pipe run is the longest, either inlet or outlet side.</p>	

5. Partially assemble the concentric vent termination kit. Clean and cement the parts using the procedures for Joining Pipe and Fittings section of the manual. A) Cement the Y Concentric fitting to the longest of the two straight kit pipes. (See **Figure 31**) B) Cement the rain cap to the shortest of the straight kit parts. (See **Figure 31**) **NOTE:** A field supplied stainless steel screw may be used to secure the rain cap to the pipe instead of cementing when field disassembly is desired for cleaning (See **Figure 34**)

If assembly needs to be extended to meet height or side wall thickness requirement, the two pipes supplied in the kit may be replaced by using the same diameter solid, single (no coupling connections) field supplied SDR-26 PVC (ASTM D2241) pipes. Do not extend dimension D more than 60". (See **Figure 33**)

Do not use field supplied couplings to extend the pipes. Airflow restriction will occur and the furnace pressure switch may cause intermittent operation.

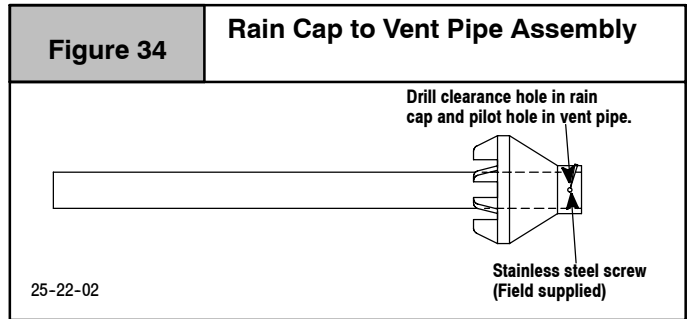

**⚠ WARNING**

**CARBON MONOXIDE POISONING HAZARD.**  
Failure to follow this warning could result in personal injury or death.

When using the alternate screw assembly method, drill a clearance hole in the rain cap and a pilot hole in the vent pipe for the screw size being used. Failure to drill adequate holes may cause cracking of the PVC components, allowing flue gases to be recirculated.

**⚠ WARNING**

**CARBON MONOXIDE POISONING HAZARD.**  
Failure to follow this warning could result in personal injury or death.

Do not operate the furnace with the rain cap removed as recirculating of the flue gases may occur. Water may also collect inside the larger combustion air pipe and flow to the burner enclosure.

6. Install the Y concentric fitting and the pipe assembly through the structure's hole. For vertical termination, install the parts through the field supplied roof boot/flashing. **NOTE:** Do not allow insulation or other materials to accumulate inside the pipe assembly when installing through the structure's hole.
7. Secure the assembly to the structure as shown in **Figure 32** or **Figure 36** using field supplied metal strapping or equivalent material.
 

**NOTE:** Ensure the termination height is above the roof surface or anticipated snow level as shown in **Figure 32** for vertical termination. Ensure the termination location clearance dimensions are as shown in **Figure 35** and **Figure 36** for horizontal termination.
8. Install the rain cap and the small diameter pipe assembly in the Y concentric fitting and the large pipe assembly. Ensure that the small diameter pipe is bottomed out and securely cemented in the Y concentric fitting.
9. Cement the furnace combustion air and vent pipes to the concentric vent termination assembly. See **Figure 32** or **Figure 36** for proper pipe attachment.
10. Operate the furnace through one heat cycle to ensure combustion air and vent pipes are properly connected to the concentric termination connections.



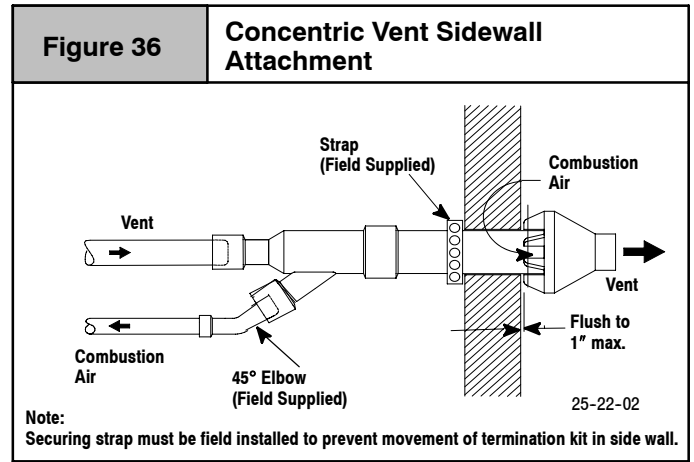
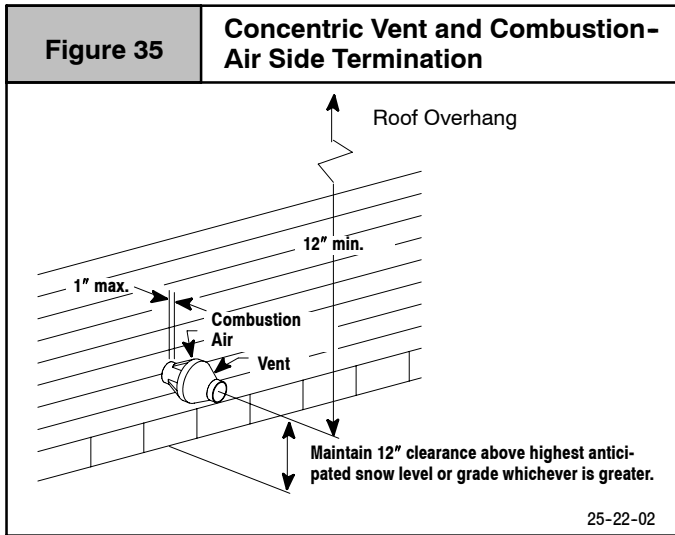

## 6. Gas Supply and Piping

**⚠ WARNING**

**FIRE AND EXPLOSION HAZARD.**  
Failure to follow this warning could result in personal injury, death and/or property damage. Models designated for Natural Gas are to be used with Natural Gas ONLY, unless properly converted to use with Propane gas.

**NOTE:** The rating plate is stamped with the model number, gas type and gas input rating. In addition, models manufactured for sale in Canada have orifice size information stamped on the rating plate.

### Gas Supply Requirements

Gas supply pressure should be within minimum and maximum values listed on rating plate. Pressures are usually set by gas suppliers.

(See Propane Gas Conversion Kit instruction manual for furnaces converted to Propane gas)

- Use only the Type of gas approved for this furnace. See rating plate for approved gas type.
- A 1/8" NPT plugged tapping, accessible for a test gauge connection, must be installed immediately upstream of the gas supply connection to furnace.
- Gas supply pressure should be within minimum and maximum values listed on rating plate. Pressures are usually set by gas suppliers.
- Gas input must not exceed the rated input shown on the rating plate. Overfiring will result in failure of heat exchanger and cause dangerous operation.
- Do **NOT** allow minimum gas supply pressure to vary downward. Doing so will decrease input to furnace. Refer to **Table 8**, **Table 9**, **Table 10**, **Table 11** and **Table 12** for normal gas supply and manifold pressures.

Table 7		Gas Pressures		
Gas Type	Supply Pressure			
	Recommended	Max.	Min.	
Natural	7"	14"	4.5"	
Propane	11"	14"	11"	

### Gas Piping Requirements

**NOTE:** The gas supply line must be installed by a qualified service technician in accordance with all building codes.

**NOTE:** In the state of Massachusetts.

- a. Gas supply connections **MUST** be performed by a licensed plumber or gas fitter.
  - b. When flexible connectors are used, the maximum length shall not exceed 36".
  - c. When lever handle type manual equipment shutoff valves are used, they shall be T-handle valves.
  - d. The use of copper tubing for gas piping is **NOT** approved by the state of Massachusetts.
1. Install gas piping in accordance with local codes, or in the absence of local codes, the applicable national codes. Refer to NFGC and ANSI Z223.1 for proper gas pipe size.
  2. It is recommended that a manual equipment shutoff valve be installed in the gas supply line outside the furnace. Locate valve as close to the furnace as possible where it is readily accessible. Refer to **Figure 37**.
  3. Use black iron or steel pipe and fittings or other pipe approved by local code.
  4. Use pipe thread compound which is resistant to natural and Propane gases.
  5. Use ground joint unions and install a drip leg no less than 3" long to trap dirt and moisture before it can enter gas control valve inside furnace.

**NOTE:** Refer to **Figure 37** or **Figure 38** for the general layout at the furnace. The rules listed apply to natural and Propane gas pipe installations.

**NOTE:** On the Dual Certified or Direct Vent models, install the gas pipe grommet to the furnace side panel with the gas pipe entry. If needed, remove the 2" hole plug from the plastic accessory bag and relocate to the open hole in the furnace side panel.



# WARNING

## FIRE OR EXPLOSION HAZARD.

Failure to follow this warning could result in personal injury, death and/or property damage.

A flexible corrugated metal gas connector must be properly installed, shall not extend through the side of the furnace, and shall not be used inside the furnace.

Black iron pipe shall be installed at the furnace gas control valve and extend a minimum of 2" outside furnace casing.

6. Use two pipe wrenches when making connections to prevent gas valve from turning.
7. Install a manual shut-off valve external to furnace casing and tighten all joints securely.
8. If local codes allow the use of flexible gas appliance connectors, always use a new listed connector. Do not use a connector which has previously serviced another appliance.
9. Flexible corrugated metal gas connector may **NOT** be used inside the furnace or be secured or supported by the furnace or ductwork.
10. Properly size gas pipe to handle combined appliance load or run gas pipe directly from gas meter or Propane gas regulator.
11. Install correct pipe size for run length and furnace rating.
12. Measure pipe length from gas meter or Propane second stage regulator to determine gas pipe size.

**Figure 37** Typical Gas Piping for Upflow

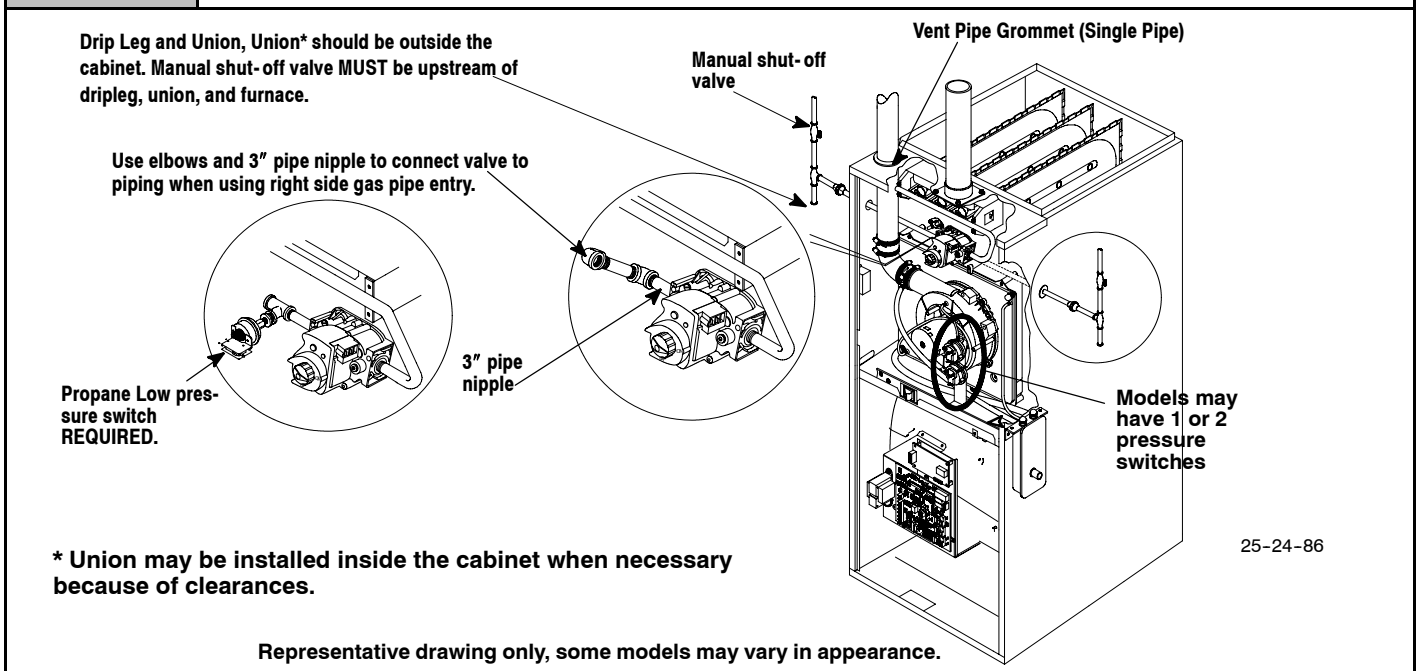

**Figure 38** Typical Gas Piping for Downflow

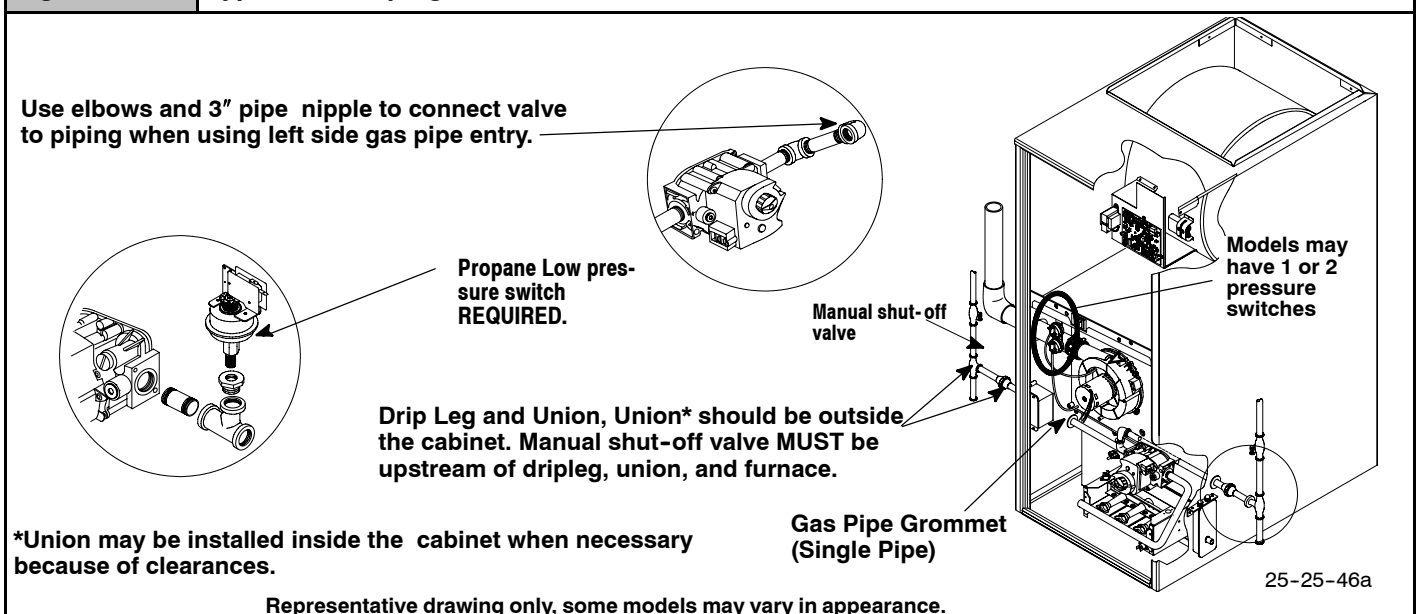

## Additional Propane Connection Requirements

1. Have a licensed Propane gas dealer make all connections at storage tank and check all connections from tank to furnace.
2. If copper tubing is used, it **MUST** comply with limitation set in National Fuel Gas Code or CGA codes.
3. Two-stage regulation of Propane gas is recommended.

## Propane Conversion

An accessory kit shall be used to convert to propane gas use, see the furnace rating plate for the Propane conversion accessory kit part number.

⚠ **WARNING**

**FIRE, EXPLOSION, UNIT DAMAGE HAZARD.**  
**Failure to follow this warning could result in death, property damage and/or personal injury.**  
**A Propane conversion accessory kit is required when operating the furnace with Propane gas.**

## Alternate BTUH Input Ratings (USA Only)

The input rating of these furnaces can be changed from the standard input rating to the alternate input rating shown in **Table 8**, by changing the main burner orifices. Changing of burner orifices **MUST** be done by a qualified service technician. See section on changing orifices or following page.

Table 8		Alternate Input Ratings, USA ONLY.	
BTUH Standard Rating	BTUH Alternate Rating	Natural Gas Orifice*	Propane Gas Orifice**
50,000	40,000	#44	#55
75,000	60,000	#44	#55
100,000	80,000	#44	#55
125,000	100,000	#44	#55

\* See **Table 11** for High Altitude

\*\* See **Table 12** for High Altitude

## Manifold Gas Pressure Adjustment

**SEE CHECKS AND ADJUSTMENTS, Manifold Gas Pressure Adjustment** in this manual.

## MANIFOLD PRESSURE AND ORIFICE SIZE FOR HIGH ALTITUDE APPLICATIONS

Table 9	NATURAL GAS MANIFOLD PRESSURE (in wc) 25,000 BTU per burner													
	MEAN ELEVATION FEET ABOVE SEA LEVEL													
	0 to 2000		2001 to 3000		3001 to 4000		4001 to 5000		5001 to 6000		6001 to 7000		7001 to 8000	
HEATING VALUE at ALTITUDE BTU/CU. FT.	Orifice No.	Manifold Pressure	Orifice No.	Manifold Pressure	Orifice No.	Manifold Pressure	Orifice No.	Manifold Pressure	Orifice No.	Manifold Pressure	Orifice No.	Manifold Pressure	Orifice No.	Manifold Pressure
700	--	--	--	--	--	--	--	--	--	--	--	--	41	3.7
725	--	--	--	--	--	--	--	--	--	--	41	3.7	41	3.4
750	--	--	--	--	--	--	--	--	--	--	41	3.5	42	3.6
775	--	--	--	--	--	--	--	--	41	3.6	42	3.6	42	3.3
800	--	--	--	--	--	--	41	3.6	42	3.7	42	3.4	42	3.1
825	--	--	--	--	41	3.7	41	3.4	42	3.5	42	3.2	42	2.9
850	--	--	--	--	41	3.5	42	3.6	42	3.3	42	3.0	42	2.8
875	--	--	41	3.6	42	3.6	42	3.4	42	3.1	42	2.8	42	2.6
900	--	--	42	3.7	42	3.4	42	3.2	42	2.9	42	2.7	42	2.5
925	41	3.7	42	3.5	42	3.3	42	3.0	42	2.8	42	2.5	44	3.3
950	41	3.5	42	3.3	42	3.1	42	2.9	42	2.6	42	2.4	44	3.1
975	42	3.7	42	3.2	42	2.9	42	2.7	42	2.5	44	3.2	45	3.6
1000	42	3.5	42	3.0	42	2.8	42	2.6	42	2.4	45	3.7	45	3.4
1050	42	3.2	42	2.7	42	2.5	44	3.3	45	3.6	--	--	--	--
1100	43	3.6	42	2.5	44	3.2	45	3.6	--	--	--	--	--	--

Conversion: 1 in wc = .25 kPa

**NOTE:** Natural gas data is based on 0.60 specific gravity. For fuels with different specific gravity consult the National Fuel Gas Code ANSI Z223.1-2006/NFPA 54-2006 or National Standard of Canada, Natural Gas And Propane Installation Code CSA B149.1-05.

Table 10	PROPANE GAS MANIFOLD PRESSURE (in wc) 25,000 BTU per burner						
	MEAN ELEVATION FEET ABOVE SEA LEVEL						
	0 to 2000	2001 to 3000	3001 to 4000	4001 to 5000	5001 to 6000	6001 to 7000	7001 to 8000
HEATING VALUE at ALTITUDE BTU/CU. FT.							
2500	10.0	10.0	9.0	10.0	9.4	8.5	10.0
Orifice Size	#54	#54	#54	#55	#55	#55	#56

Conversion: 1 in wc = .25 kPa

**NOTE:** Propane data is based on 1.53 specific gravity. For fuels with different specific gravity consult the National Fuel Gas Code ANSI Z223.1-2006/NFPA 54-2006 or National Standard Of Canada, Natural Gas And Propane Installation Code CSA B149.1-05.

**NOTE:** The derating of these furnaces at 2% (Natural Gas) and 4% (Propane Gas) has been tested and design-certified by CSA. In Canada, the input rating must be derated 5% (Natural Gas) and 10% (Propane Gas) for altitudes of 2,000 to 4,500 above sea level. Use the 2001 to 3000 column in **Table 9**, **Table 10**, **Table 11** and **Table 12**.

Table 11	NATURAL GAS MANIFOLD PRESSURE (in wc) FOR THE 40k, 60k & 80k BTUH MODEL AND ALTERNATE INPUT MODELS 20,000 BTU per burner													
	MEAN ELEVATION FEET ABOVE SEA LEVEL													
	0 to 2000		2001 to 3000		3001 to 4000		4001 to 5000		5001 to 6000		6001 to 7000		7001 to 8000	
HEATING VALUE at ALTITUDE BTU/CU. FT.	Orifice No.	Manifold Pressure	Orifice No.	Manifold Pressure	Orifice No.	Manifold Pressure	Orifice No.	Manifold Pressure	Orifice No.	Manifold Pressure	Orifice No.	Manifold Pressure	Orifice No.	Manifold Pressure
700	--	--	--	--	--	--	--	--	--	--	--	--	42	3.6
725	--	--	--	--	--	--	--	--	--	--	42	3.5	42	3.4
750	--	--	--	--	--	--	--	--	--	--	42	3.3	42	3.2
775	--	--	--	--	--	--	--	--	41	2.9	43	3.7	43	3.6
800	--	--	--	--	--	--	42	3.1	43	3.6	43	3.5	43	3.4
825	--	--	--	--	43	3.7	43	3.6	43	3.4	43	3.3	44	3.6
850	--	--	--	--	43	3.5	43	3.4	44	3.7	44	3.6	44	3.4
875	--	--	43	3.4	43	3.3	44	3.6	44	3.5	44	3.4	44	3.2
900	--	--	44	3.7	44	3.6	44	3.4	44	3.3	44	3.2	44	3.1
925	44	3.7	44	3.5	44	3.4	44	3.2	44	3.1	45	3.6	45	3.5
950	44	3.5	44	3.3	44	3.2	44	3.1	45	3.6	45	3.5	45	3.3
975	44	3.3	44	3.1	45	3.7	45	3.5	45	3.4	45	3.3	45	3.2
1000	44	3.2	45	3.6	45	3.5	45	3.4	45	3.2	45	3.1	46	3.1
1050	46	3.6	45	3.3	45	3.2	45	3.1	46	3.1	--	--	--	--
1100	46	3.3	45	3.0	46	3.0	46	2.9	--	--	--	--	--	--

Conversion: 1 in wc = .25 kPa

**NOTE:** Natural gas data is based on 0.60 specific gravity. For fuels with different specific gravity consult the National Fuel Gas Code ANSI Z223.1-2006/NFPA 54-2006 or National Standard of Canada, Natural Gas And Propane Installation Code CSA B149.1-05.

Table 12	PROPANE GAS MANIFOLD PRESSURE (in wc) FOR THE 40k, 60k & 80k BTUH MODEL AND ALTERNATE INPUT MODELS 20,000 BTU per burner						
	MEAN ELEVATION FEET ABOVE SEA LEVEL						
	0 to 2000	2001 to 3000	3001 to 4000	4001 to 5000	5001 to 6000	6001 to 7000	7001 to 8000
HEATING VALUE at ALTITUDE BTU/CU. FT.							
2500	10.0	8.9	8.4	10.0	10.0	10.0	10.0
Orifice Size	#55	#55	#55	#56	#56	#56	#56

Conversion: 1 in wc = .25 kPa

**NOTE:** Propane data is based on 1.53 specific gravity. For fuels with different specific gravity consult the National Fuel Gas Code ANSI Z223.1-2006/NFPA 54-2006 or National Standard Of Canada, Natural Gas And Propane Installation Code CSA B149.1-05.

**NOTE:** The derating of these furnaces at 2% (Natural Gas) and 4% (Propane Gas) has been tested and design-certified by CSA. In Canada, the input rating must be derated 5% (Natural Gas) and 10% (Propane Gas) for altitudes of 2,000 to 4,500 above sea level. Use the 2001 to 3000 column in **Table 9**, **Table 10**, **Table 11** and **Table 12**.

The burner orifice part nos. are as follows:

Orifice #41	1096942	Orifice #42	1011351
Orifice #43	1011377	Orifice #44	1011352
Orifice #45	1011353	Orifice #46	1011744
Orifice #47	1011378	Orifice #48	1113201
Orifice #49	1113202	Orifice #54	1011376
Orifice #55	1011354	Orifice #56	1011355

## General Derating Rules

- These furnaces may be used at full input rating when installed at altitudes up to 2,000'. When installed above 2,000', the input must be decreased 2% (natural) or 4% (Propane) for each 1000' above sea level in the USA. In Canada, the input rating must be derated 5% (natural) or 10% (Propane) for each 1000' above sea level. See **Table 11** or **Table 12** for required high altitude input rate.
- For operation with natural gas at altitudes above 2,000', orifice change and/or manifold pressure adjustments may be required for the gas supplied. First consult your local gas supplier, then refer to **Table 9** for required pressure change and/or orifice change for high altitudes.
- For operation with Propane gas, gas orifices **MUST** be changed and manifold pressure **MUST** be *maintained* as per **Table 10**. Orifices can be ordered through our distributor. (See **Figure 39**)

High Altitude Input Rate = Nameplate Sea Level Input Rate x (Multiplier) [USA]		
Elevation	High Altitude Multiplier	
	Natural Gas	Propane Gas
2001' - 3000'	0.95	0.90
3001' - 4000'	0.93	0.86
4001' - 5000'	0.91	0.82
5001' - 6000'	0.89	0.78
6001' - 7000'	0.87	0.74
7001' - 8000'	0.85	0.70

\* Based on mid-range of elevation.

- In cases where **Table 9** or **Table 10** is not applicable, eg. alternate input rate application, refer to **Table 11** or **Table 12** for required high altitude input rate.

## High Altitude Air Pressure Switch

Altitudes over 4,000' may require a different air pressure switch than the one installed at the factory. Check parts list for pressure switch and consult your distributor for part number and availability. In Canada, provincial codes may govern installation of switch. Check with governing authorities.

## Changing Orifices for High Altitude



### WARNING

**ELECTRICAL SHOCK, FIRE OR EXPLOSION HAZARD.**

Failure to follow this warning could result in personal injury, death and/or property damage.

Turn OFF electric power (at disconnect) and gas supply (at manual valve in gas line) when installing orifices. Installation of orifices requires a qualified service technician.

**NOTE:** Main burner orifices can be changed for high altitudes.

1. Disconnect gas line from gas valve.
2. Remove manifold from furnace.
3. Remove the orifices from the manifold and replace them with properly sized orifices.
4. Tighten orifices so it is seated and gas tight. (See **Figure 39**)
5. Reinstall manifold. Ensure burners do **NOT** bind on new orifices.

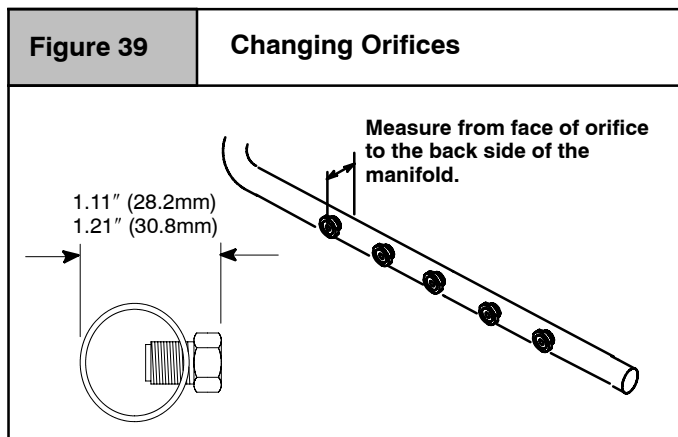

## Natural Gas Input Rating Check

SEE CHECKS AND ADJUSTMENTS, Natural Gas Input Rating Check in this manual.

## 7. Electrical Wiring



### WARNING

**ELECTRICAL SHOCK HAZARD.**

Failure to follow this warning could result in personal injury or death.

Turn OFF electrical power at fuse box or service panel before making any electrical connections and ensure a proper ground connection is made before connecting line voltage.

### Power Supply Wiring

The furnace **MUST** be electrically wired and grounded in accordance with local codes, or in the absence of local codes with the latest edition of The National Electric Code, ANSI NFPA 70 and/or The Canadian Electric Code CSA C22.1.

## Final Gas Piping Check



### WARNING

**FIRE OR EXPLOSION HAZARD.**

Failure to follow this warning could result in personal injury, death, and/or property damage.

Never test for gas leaks with an open flame. Use a commercially available soap solution made specifically for the detection of leaks to check all connections. A fire or explosion could result causing property damage, personal injury and/or loss of life.

1. The furnace and the equipment shut off valve must be disconnected from the gas supply piping system during any pressure testing of that system at test pressures in excess of  $1/2$ " PSIG. Close the manual shut-off valve before testing at such pressures.
2. When installation is complete, test all pipe connections for leaks with the gas pressure less than  $1/2$ " PSIG to the gas valve.
3. The furnace must be isolated from the gas supply system by closing the equipment shut off valve during any pressure testing of the gas supply system at test pressure equal to or less than  $1/2$ " PSI.
4. Apply a commercial soap solution to all joints to test for leaks. Correct any leaks indicated by bubbles.
5. Correct even the smallest leak at once.
6. Check for leaks at gas valve and orifice connections to the burner manifold while the furnace is operating.



### AVERTISSEMENT

**RISQUE D'INCENDIE OU D'EXPLOSION.**

Le non-respect des avertissements de sécurité pourrait d'entraîner des blessures graves, la mort ou des dommages matériels.

Ne jamais utiliser une flamme nue pour vérifier la présence des fuites de gaz. Pour la vérification de tous les joints, utiliser plutôt une solution savonneuse commerciale fabriquée spécifiquement pour la détection des fuites de gaz. Un incendie ou une explosion peut entraîner des dommages matériels, des blessures ou la mort.

The power supply to the furnace connections must be between 104 VAC and 127 VAC during furnace operation for acceptable performance.

Field wiring connections must be made inside the furnace connection box. A suitable strain relief should be used at the point the wires exit the furnace casing.

**Copper conductors shall be used.** Line voltage wires should conform to temperature limitation of 63° F (35° C) rise and be sized for the unit maximum amps stated on the rating plate. Add the full load amps for potential field-installed accessories such as electronic air cleaners and humidifiers that would receive power from the furnace control. The furnace control is rated for a maximum of 1.0 amps combined for EAC and HUM. Consult NEC or local codes for proper wire and circuit sizing.

**NOTE:** Furnace will not have normal operation if line polarity is reversed. Check ALL field and control connections prior to operation.

## Junction Box (J-Box) Relocation

The J-Box is installed on left side of casing. An alternate J-Box location on right side can be used.

1. Remove bag containing two hole plugs and two self tapping screws from loose parts bag in blower compartment.
2. Remove two screws holding J-Box to casing.
3. Move large hole plug from right to left J-Box location.
4. Clip wire tie holding J-Box wires.
5. Move J-Box to alternate location and attach using two self tapping screws from bag.
6. Apply two hole plugs from bag at left J-Box location.

## Thermostat

Thermostat location has an important effect on the operation of the unit. Follow instructions included with thermostat for correct mounting and wiring.

Low voltage connections to furnace must be made on terminal board of furnace control.

Heat anticipator setting will need to be measured if 24VAC humidifier is installed. Measure current in series from R to W at the thermostat. Be sure 24VAC humidifier is wired up to control. Allow furnace to operate for 2 minutes before recording the AC amperage reading. Set anticipator on thermostat to recorded value.

## Optional Equipment

All wiring from furnace to optional equipment **MUST** conform to local codes or, in the absence of local codes with the latest edition of The National Electric Code, ANSI NFPA 70 and/or The Canadian Electric Code CSA C22.1. Install wiring in accordance with manufacturer's instructions. The wiring **MUST** have a minimum temperature rating of 105° C.

## Humidifier/Electronic Air Cleaner

The furnace is wired for humidifier and/or electronic air cleaner connection.



# CAUTION

**REDUCED FURNACE LIFE HAZARD.**

**Failure to follow caution may result in reduced furnace life.**

**Do NOT exceed 115V/1.0 amp. maximum current load for both the EAC terminal and the HUM terminal combined.**

**HUMIDIFIER** - The HUM (115) is energized when the pressure switch closes on a call for heat. The HUM is energized when the inducer is energized.

**ELECTRONIC AIR CLEANER** - EAC is energized when there is a blower speed call, except is NOT energized when blower operates in the hard-wired continuous fan mode.

## Furnace Control

The furnace control is preset at the factory with a fixed blower **ON** delay of 30 seconds in the heating mode. The blower **OFF** timing is preset at 140 seconds. If desired, the fan **OFF** delay can be reset to obtain the longest delay times while still maintaining comfort levels. See "Furnace Wiring Diagram" .

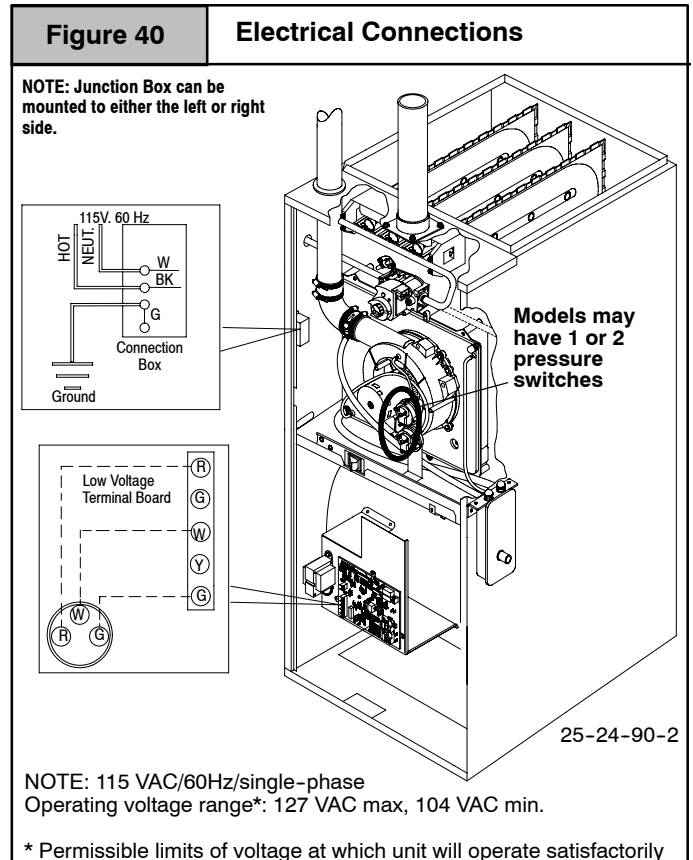

## Furnace Control Fuse

The 24V circuit contains a 5-amp, automotive-type fuse located on furnace control. (See **Figure 41**) Any electrical shorts of 24V wiring during installation, service, or maintenance may cause fuse to blow. If fuse replacement is required, use only a fuse of identical size (5 amp.)

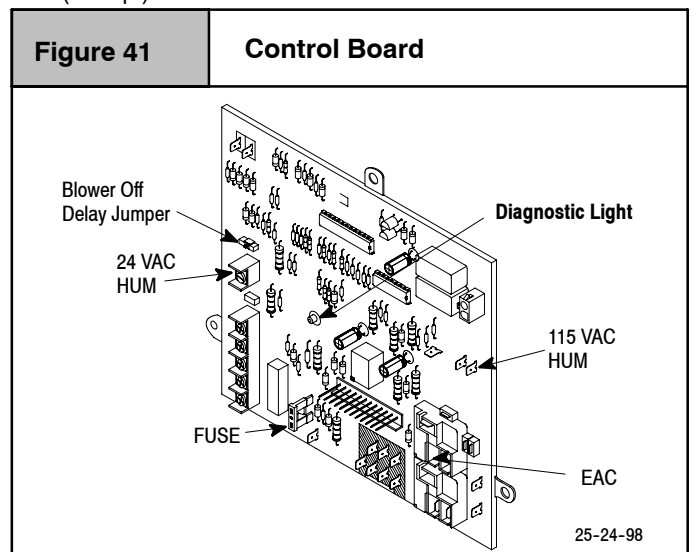

## 8. Ductwork and Filter



### WARNING

#### CARBON MONOXIDE POISONING HAZARD.

Failure to follow this warning could result in personal injury or death.

Do NOT draw return air from inside a closet or utility room where furnace is located. Return air duct MUST be sealed to furnace casing.

### Installation

**NOTE:** Design and install the air distribution system to comply with Air Conditioning Contractors of America manuals and/or NFPA pamphlets 90A and 90B or other approved methods that conform to local codes and good trade practices.

1. When furnace supply ducts carry air outside furnace area, seal return air duct to furnace casing and terminate duct outside furnace space.
2. Install air conditioning cooling coil (evaporator) on outlet side of furnace.
3. For furnaces installed without a cooling coil it is recommended that the outlet duct be provided with a removable access panel. This panel should be accessible when the furnace is installed so the exterior of the heat exchanger can be viewed for inspections. The access panel **MUST** be sealed to prevent leaks.
4. If separate evaporator and blower units are used, install good sealing dampers for air flow control. Chilled air going through the furnace could cause condensation and shorten the furnace life.

**NOTE:** Dampers (field supplied) can be either automatic or manual. Manually operated dampers **MUST** be equipped with a means to prevent furnace or air conditioning operation unless damper is in the full heat or cool position.



### WARNING

#### CARBON MONOXIDE POISONING HAZARD.

Failure to follow this warning could result in death or personal injury.

Cool air passing over heat exchanger can cause condensate to form resulting in heat exchanger failure.

### Connections

**NOTE:** On upflow installations, return air can enter through either side, both sides, or the bottom. On horizontal or downflow installations the return air must enter through the knockout opening in the lower panel of the furnace. Return air **can not** enter through rear of the furnace. When the furnace is located in an area near or adjacent to the living area, the system should be carefully designed with returns to minimize noise transmission through the return grille. Any blower moving a high volume of air will produce audible noise which could be objectionable to when the unit is located very close to living areas. It is advisable to route the return air ducts under the floor or through the attic.

1. For side connections using a 16" x 25" filter, cut out the embossed area shown in **Figure 42**. This will provide a  $14\frac{1}{2}" \times 22\frac{1}{2}"$  approximate opening.

Figure 42

Side Return Air Cutout

A =  $14\frac{1}{2}"$  Height of Cutout for 16" x 25" Filter  
B =  $22\frac{1}{2}"$  Width of Cutout for 16" x 25" Filter

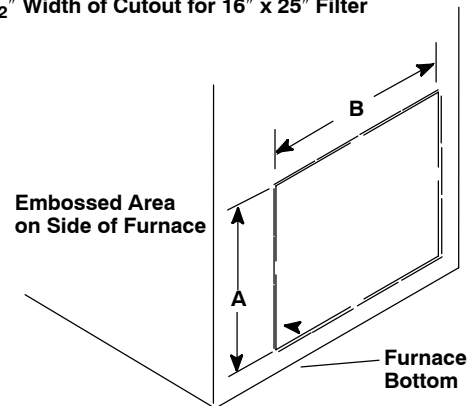

**NOTE:** Furnaces with 5 ton cooling rating may require both (left and right) side return or one side and bottom return (see notes in Circulation Air Blower Data). Side return air duct(s) is not permitted with horizontal or downflow furnace installation.

2. Bottom returns can be made by removing the knockout panel in the furnace base. Do **NOT** remove knock-out except for a bottom return.
3. Installation of locking-type dampers are recommended in all branches, or in individual ducts to balance system's air flow.
4. Non-combustible, flexible duct connectors are recommended for return and supply connections to furnace.
5. If air return grille is located close to the fan inlet, install at least one, 90° air turn between fan and inlet grille to reduce noise.

**NOTE:** To further reduce noise, install acoustical air turning vanes and/or line the inside of duct with acoustical material.

### Sizing

Existing or new ductwork **MUST** be sized to handle the correct amount of airflow for either heating only or heating and air conditioning.

### Insulation

1. Insulate ductwork installed in attics or other areas exposed to outside temperatures with a minimum of 2" insulation and vapor barrier.
2. Insulate ductwork in indoor unconditioned areas with a minimum of 1" insulation with indoor type vapor barrier.

### Filters

A Filter **must** be used:

Filters are not supplied with these furnaces, but can be purchased from the distributor.

Use either filter type:

- Washable, high velocity filters are based on a maximum air flow rating of 600 FPM.
- Disposable, low velocity filters are based on a maximum air flow of 300 FPM when used with filter grille.
- See *Circulating Air Blower Data* for additional data.

**NOTE:** Disposable, low velocity filters may be replaced with washable, high velocity filter providing they meet the minimum size areas. Washable, high velocity filters can be replaced **ONLY** with same type and size.

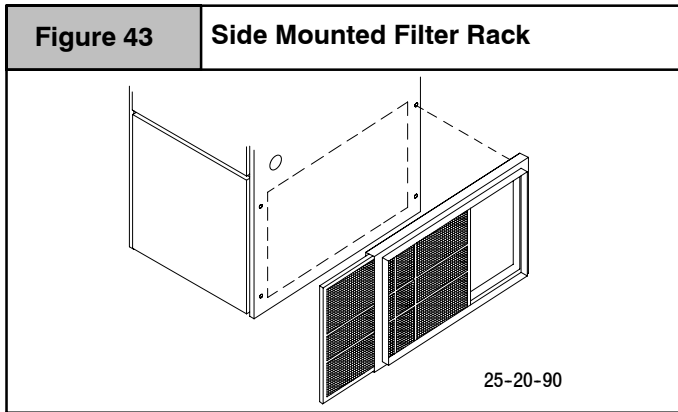

## Filter Installation using Optional Filter Rack

When installing or removing a bottom mounted filter, slide the two side filter clips to the back of the furnace **BEFORE** installing or removing. This will allow the filter to clear the front raised edge of the furnace. Insert filter into side clips first and push filter back until it is fully engaged into back clip. When filter is in place, slide clips back into place midway on filter as shown in **Figure 44** and **Figure 45**.

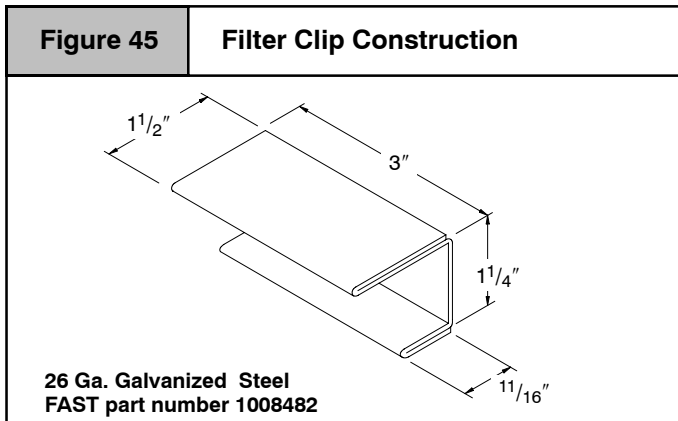
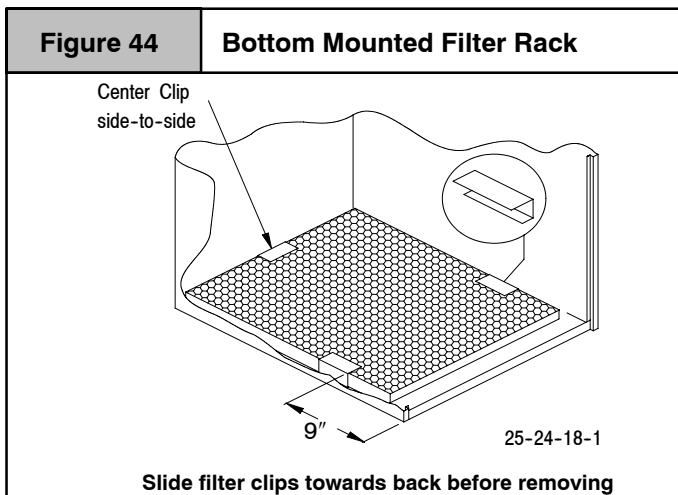

Refer to **Figure 46** and for guidelines to install filters. Furnaces which require larger filter media and have limited clearances on one side of furnace, require a standoff filter rack, see **Figure 46**, available from your distributor.

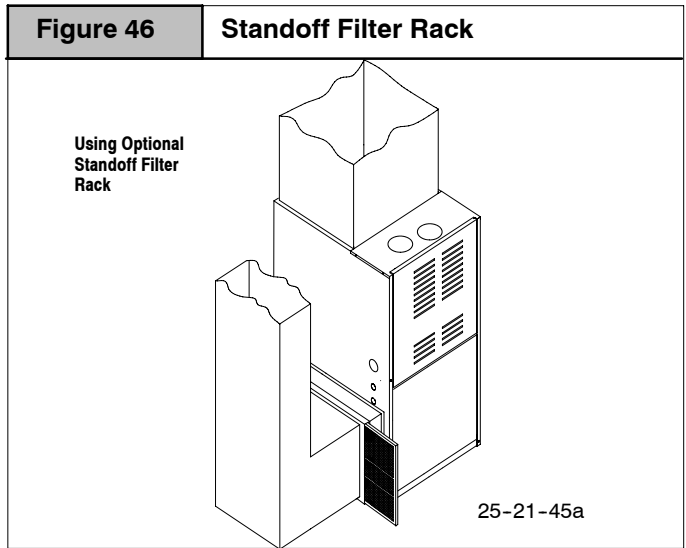

**⚠ CAUTION**  
**REDUCED FURNACE LIFE HAZARD.**  
 Failure to follow this caution may result in reduced furnace life.  
 If filters are only suitable for heating application, advise homeowner that filter size may need to be increased if air conditioning is added.

## Addition Of Air Conditioning

When a refrigeration coil is used in conjunction with this unit, it must be installed parallel with or on the discharge side of the unit to avoid condensation on the heat exchanger. All furnaces are designed with a break-away duct flange on the supply air side of the furnace. This allows for installation in the horizontal right or downflow applications. The coil installation instructions must be consulted for proper coil location and installation procedures. With a parallel flow arrangement, dampers must be installed to prevent chilled air from entering the furnace. If manually operated dampers are used, they must be equipped with a means to prevent operation of either unit unless the damper is in full heat or full cool position.

A 3" clearance is required on the right side of the furnace in order to run the copper or plastic condensate drain line.

## Downflow Furnace Installation

### Non-Combustible Floor Installation

Fabricate a plenum to the dimensions given in **Table 13**, for the furnace outlet. Plenum should be flanged, approximately  $\frac{3}{4}$ " for support.

Note: The three(3) screws in the top panel of the furnace next to the duct flange **MUST** be removed to provide serviceability of the primary heat exchangers in the downflow installation

1. Position plenum through the floor and set the furnace over the opening in the floor. If necessary, grout around the base to seal air leaks between the base and the floor.

### Combustible Floor Installation

**⚠ WARNING**  
**FIRE HAZARD.**  
 Failure to follow this warning could result in personal injury, death and/or property damage.  
 Place furnace on noncombustible subbase on downflow applications, unless installing on non-combustible flooring.



## Subbase for Combustible Floor

**NOTE:** The three(3) screws in the top panel of the furnace next to the duct flange **MUST** be removed to provide serviceability of the primary heat exchangers in the downflow installation

Note: When using the subbase for combustible floors, the discharge air duct flanges on the furnace **MUST** be broken down to provide proper fit up to the subbase. Use duct pliers to bend the duct flanges flat onto the furnace casing. **DO NOT** bend the duct flanges inward (toward the heat exchangers) as air flow restrictions may occur.

The Subbase for Combustible Floors **MUST** be used when a

downflow furnace is set on a combustible floor, even when the furnace is installed on a coil box.

1. Cut the opening in the floor according to **Table 13**. The hole in the floor must be cut to the dimensions listed in **Table 13** since the base is equipped with locating tabs that center the base over the opening.

The opening in the base is  $1\frac{1}{4}$ " shorter and  $1\frac{1}{8}$ " narrower than the recommended size of the opening in the floor. This is done to maintain clearance between the floor and the plenum.

2. Fabricate the plenum to the dimensions given in **Table 13**. Note that the dimensions given are outside dimensions.

Table 13		Subbases for Combustible Floors Dimensions									
Sub-base for Combustible Floors Part Number	Sub-base for Combustible Floor Dimensions				Opening In Floor		Opening In Base For Plenum		Typical Plenum Dimensions		
	H*	J*	K**	L	M	N	P	R	S	T	
<b>Furnace Only</b>											
NAHH001SB	$15\frac{11}{16}$	$28\frac{3}{4}$	$14\frac{9}{16}$	16	$16\frac{1}{4}$	$14\frac{5}{8}$	15	$13\frac{1}{2}$	15	$13\frac{1}{2}$	
NAHH002SB	$19\frac{5}{16}$	$28\frac{3}{4}$	$18\frac{3}{16}$	16	$16\frac{1}{4}$	$18\frac{1}{4}$	15	$17\frac{1}{8}$	15	$17\frac{1}{8}$	
NAHH003SB	$22\frac{15}{16}$	$28\frac{3}{4}$	$21\frac{13}{16}$	16	$16\frac{1}{4}$	$21\frac{7}{8}$	15	$19\frac{3}{4}$	15	$19\frac{3}{4}$	
NAHH010SB	$24\frac{11}{16}$	$28\frac{3}{4}$	$23\frac{9}{16}$	16	$16\frac{1}{4}$	$23\frac{5}{8}$	15	$22\frac{1}{2}$	15	$22\frac{1}{2}$	
<b>Subbase for Coil Box</b>											
NAHH004SB	$15\frac{3}{4}$	$20\frac{9}{16}$	$14\frac{9}{16}$	$16\frac{1}{16}$	$16\frac{1}{4}$	$14\frac{5}{8}$	15	$13\frac{1}{2}$	15	$13\frac{1}{2}$	
NAHH005SB	$19\frac{3}{8}$	$20\frac{9}{16}$	$18\frac{3}{16}$	$16\frac{1}{16}$	$16\frac{1}{4}$	$18\frac{1}{4}$	15	$17\frac{1}{8}$	15	$17\frac{1}{8}$	
NAHH006SB	23	$20\frac{9}{16}$	$21\frac{13}{16}$	$16\frac{1}{16}$	$16\frac{1}{4}$	$21\frac{7}{8}$	15	$19\frac{3}{4}$	15	$19\frac{3}{4}$	
NAHH009SB	$24\frac{3}{4}$	$20\frac{9}{16}$	$23\frac{9}{16}$	$16\frac{1}{16}$	$16\frac{1}{4}$	$23\frac{5}{8}$	15	$22\frac{1}{2}$	15	$22\frac{1}{2}$	

\* Outside Dimension  
 \*\* Base Spacer Side To Side

3. Set the base over the opening in the floor, centering it over the opening. Fasten the base to the floor with screws or nails. See **Figure 47**, **Figure 48** and **Figure 49**.
4. Drop the plenum through the opening in the base. The flange of the plenum should rest on top of the subbase.
5. Position furnace or coil cabinet and furnace on subbase so it aligns between the locating tabs.

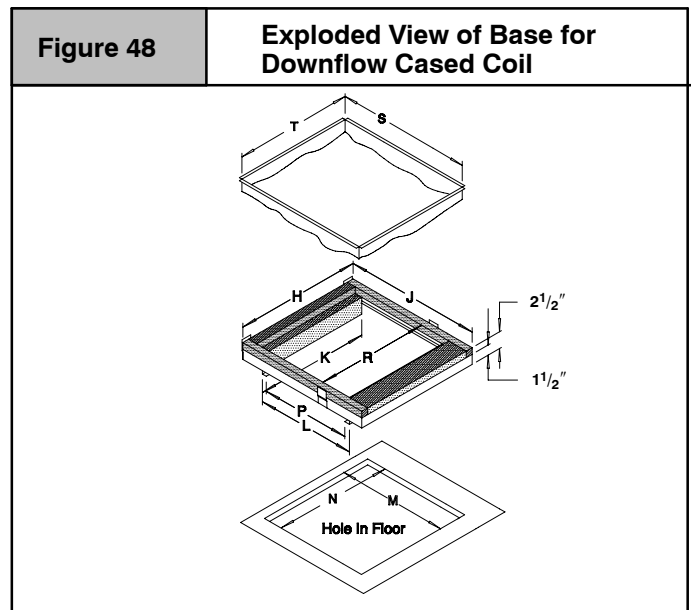
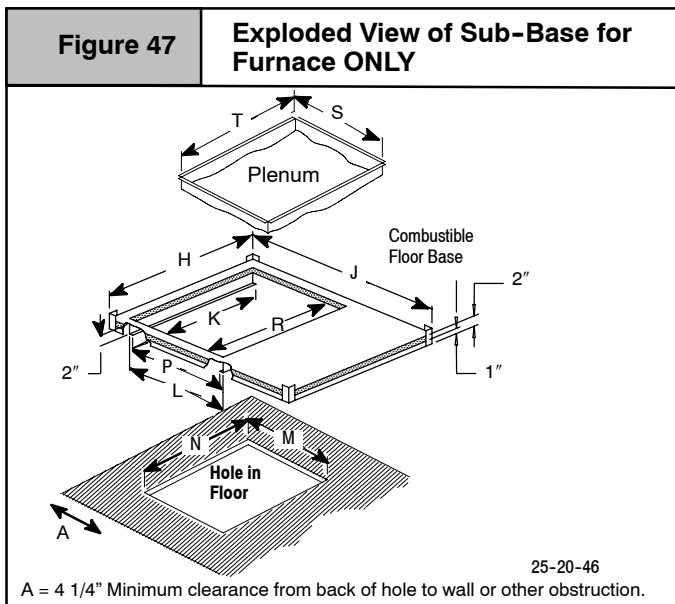

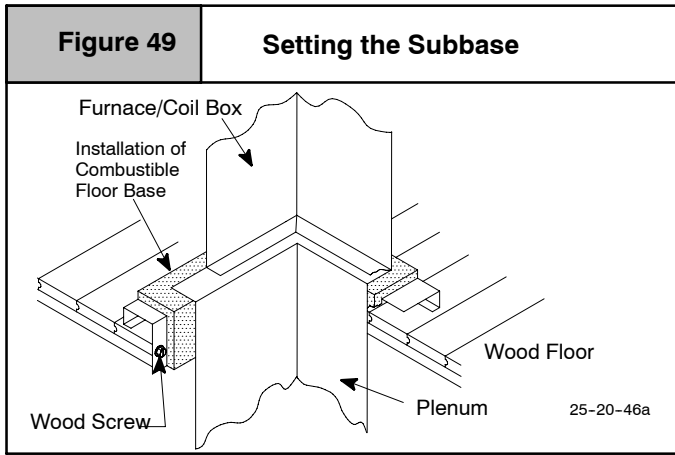

This subbase for combustibile floors has been designed so that the height of the subbase raises the downflow coil off the floor to allow easy installation of the condensate drain. See **Figure 50**.

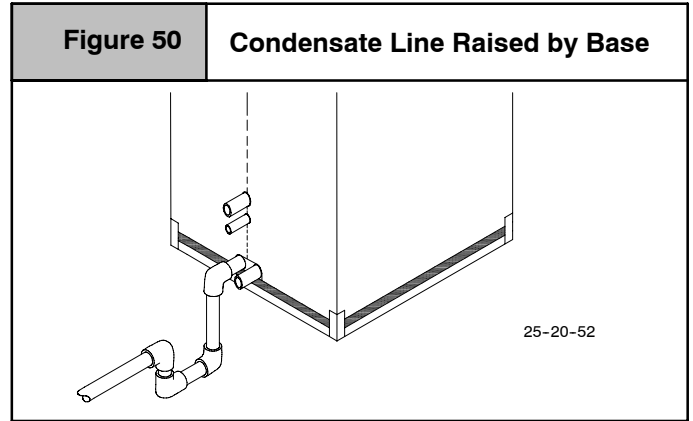

## 9. Checks and Adjustments

**NOTE:** Verify the input rate of the furnace.

**⚠ WARNING**  
**FIRE OR EXPLOSION HAZARD.**  
Failure to follow this warning could result in personal injury, death and/or property damage.  
Turn OFF gas at shut off before connecting manometer.

### Startup

**NOTE:** Refer to the start-up procedures in the "User's Information Manual" or to the "Operating Instructions Label" on the furnace.

**⚠ WARNING**  
**FIRE OR EXPLOSION HAZARD.**  
Failure to follow this warning could result in personal injury, death and/or property damage.  
If any sparks, odors or unusual noises occur, immediately shut OFF power to furnace. Check for wiring errors or obstruction to blower.

### Gas Supply Pressure

Gas supply pressure should be within minimum and maximum values listed on rating plate. Pressures are usually set by gas suppliers.

### Manifold Gas Pressure Adjustment

**NOTE:** Make adjustment to manifold pressure with burners operating.

1. Remove the burner compartment door.
2. Remove the blower compartment door. Place a jumper across furnace controls **R** to **W**. Replace blower compartment door.
3. With gas **OFF**, connect manometer to tapped opening on gas valve. Use manometer with a 0 to 15 inch water column range.
4. Turn gas **ON** and remove adjustment screw cover on gas valve. Turn adjusting screw counterclockwise to decrease manifold pressure and clockwise to increase pressure.

**Figure 51**      **Typical Gas Control Valve**

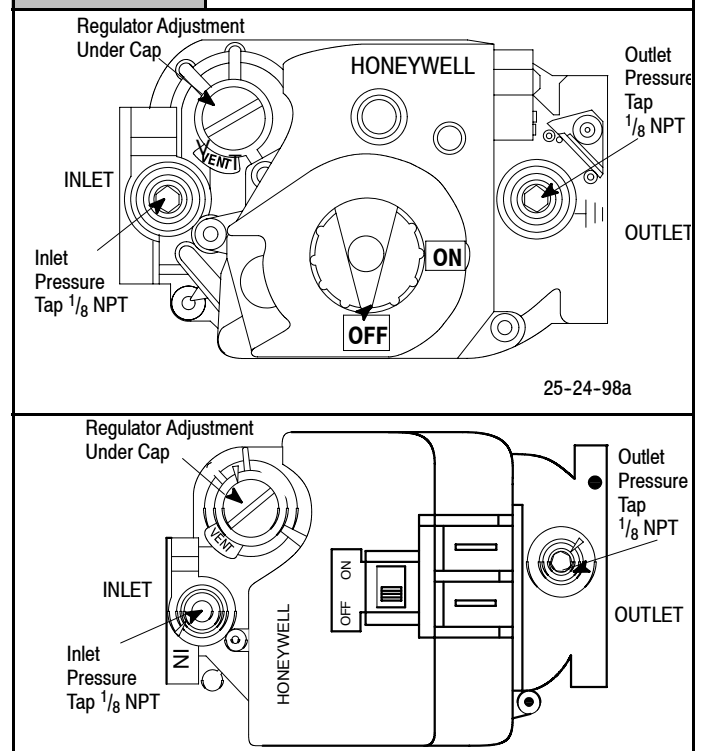

**NOTE:** Adjustment screw cover **MUST** be replaced on gas control valve before reading manifold pressure and operating furnace.

5. Set manifold pressure to value as shown in **Table 9**, **Table 10**, **Table 11** or **Table 12** under **GAS SUPPLY AND PIPING** section in this manual.
6. When the manifold pressure is properly set, replace the adjustment screw cover on the gas control valve.
7. Remove blower compartment door. Remove jumper wire from thermostat connection on furnace control board. Remove manometer connection from manifold pressure tap, and replace plug in manifold.
8. Check for leaks at plug.
9. Replace the burner and blower compartment doors.

### Natural Gas Input Rating Check

**NOTE:** The gas meter can be used to measure input to furnace. Rating is based on a natural gas BTU content of 1,000 BTU's per cubic meter. Check with gas supplier for actual BTU content.

1. Turn **OFF** gas supply to all appliances and start furnace. Use jumper wire on **R** to **W** for Heat.
2. Time how many seconds it takes the smallest dial on the gas meter to make one complete revolution. Refer to **Example**.

**NOTE:** If meter uses a 2 cubic foot dial, divide results (seconds) by two.

Example			
Natural Gas BTU Content	No. of Seconds Per Hour	Time Per Cubic Foot in Seconds	BTU Per Hour
1,000	3,600	48	75,000
$1,000 \times 3,600 \div 48 = 75,000$ BTUH			

3. Remove jumper wire from **R** to **W**.
4. Relight all appliances and ensure all pilots are operating.

## Main Burner Flame Check

Allow the furnace to run approximately 10 minutes then inspect the main burner. See **Figure 52**.

Check for the following (**Figure 52**):

- Stable and blue flames. Dust may cause orange tips or wisps of yellow, but flames **MUST NOT** have solid, yellow tips.
- Flames extending directly from burner into heat exchanger.
- Flames do **NOT** touch sides of heat exchanger.

If any problems with main burner flames are noted, it may be necessary to adjust gas pressures, or check for drafts.

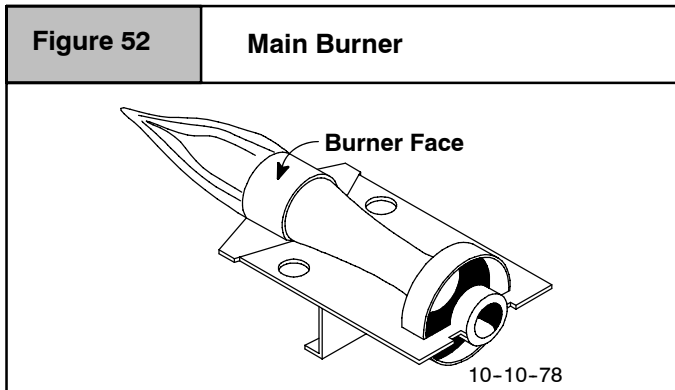

**NOTE:** For Ignitor location see **Figure 53**.

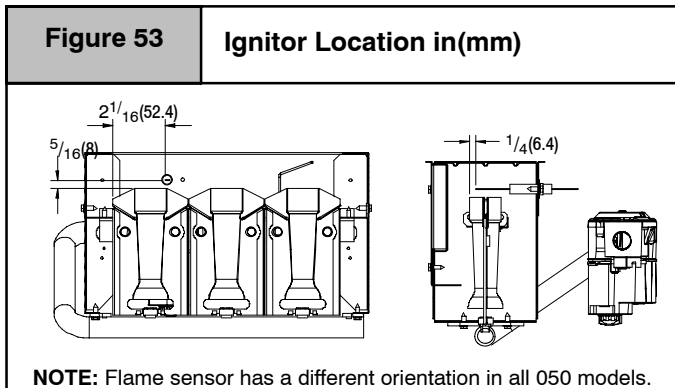

## Temperature Rise Check

The blower speed **MUST** be set to give the correct air temperature rise through the furnace as marked on the rating plate. Temperature rise is the difference between supply and return air temperatures.

To check temperature rise, use the following procedure:

1. Place thermometers in supply and return air registers as close to furnace as possible, avoiding direct radiant heat from heat exchangers.
2. Operate furnace continuously for 15 minutes with all registers and duct dampers open.
3. Take reading and compare with range specified on rating plate.
4. If the correct amount of temperature rise is **NOT** obtained, it may be necessary to change blower speed. A higher blower speed will lower the temperature rise. A lower blower speed will increase the temperature rise.

## Changing Blower Speed

<b>⚠</b>	<b>WARNING</b>
<p><b>ELECTRICAL SHOCK HAZARD.</b>  <b>Failure to follow this warning could result in personal injury or death.</b>  <b>Turn OFF power to furnace before changing speed taps.</b></p>	

**NOTE:** The speed taps that the manufacturer sets from the factory for this product are based on a nominal 400 CFM per ton cooling and the basic mid range on the temperature rise for heating.

**Since the manufacturer cannot establish the static pressure that will be applied to the unit, it is the responsibility of the installer dealer/contractor to select the proper speed taps for the application when the unit is installed.**

If it is necessary to change speeds, refer to steps below.

<b>⚠</b>	<b>CAUTION</b>
<p><b>REDUCED FURNACE LIFE HAZARD.</b>  <b>Failure to follow this caution may result in reduced furnace life.</b>          Use <b>ONLY</b> the blower motor speed taps insert indicated in the <b>Circulation Air Blower Data</b> for setting air temperature rise.</p>	

Table 14	Blower Speed Chart	
	Wire Color	Motor Speed
	Black	High
	Orange*	Med-High
	Blue	Medium
	Red	Low
* Med-High speed may not be provided on all models.		

1. Refer to *Furnace Wiring Diagram* for location of the heating and cooling speed taps located on the furnace control as well as location of unused blower motor speed leads. Use the chart (**Table 14**) to determine the blower motor speed settings.
2. Change the heat or cool blower motor speed by removing the motor lead from the "Heat" or "Cool" terminal and replace it with the desired motor speed lead from the "Unused Motor Lead" location. Connect the wire previously removed from the "Heat" or "Cool" terminal to the vacated "Unused Motor Lead" terminal.

3. If the same speed must be used for both heating and cooling, remove the undesired motor speed lead from the "Heat" or "Cool" terminal and connect that lead to the open terminal at "Unused Motor Lead" location. Attach a jumper between the "Heat" and "Cool" terminals and the remaining motor speed lead.

**Note:** For motors with (4) speed leads, it will be necessary to tape off the terminal of the motor speed lead removed from the "Heat" or "Cool" terminal with electrical tape since an open terminal will not be available at the "Unused Motor Lead" location.

### Continuous-Fan Operation using "G"

Energizing the "G" terminal on the furnace control provides continuous fan operation. This is done by connecting the G terminal of the thermostat to the G terminal on the furnace control. When the FAN switch is turned from auto to ON the fan will operate continuously at "HEAT" speed. EAC will be energized in this mode.

**NOTE:** In heating, the fan will turn off during furnace ignition and warm up then restart at heating speed.

### Hard Wired Continuous Fan Operation

A terminal is provided on the furnace control board located in the

circulating blower compartment for operation of the continuous fan option. This connection is intended for the low speed motor tap, and has a lower contact rating (8 amps) than the heat and cool taps. When the low speed blower lead is connected to this terminal, this will provide low speed blower operation whenever the other two speeds (Heat or Cool) are not energized.

Thoroughly check the system after modification to ensure the proper operation of the circulating air blower in all modes of operation.

### Separate speed selections for Heat, Cool, and Continuous Fan

Connect low speed lead from circulating motor to the "Cont." terminal at the furnace control. The appropriate motor leads should already be connected to the "Heat" and "Cool" terminals.

### Heating and Continuous Blower Speed the Same

If it is necessary to operate the heating speed and continuous blower speed using the same blower speed, connect a jumper between the "Heat" and "Cont." terminals on the furnace control.

**Note:** There should be only **ONE** motor lead going to the "Heat" and "Cont." terminals.

## 10. Furnace Maintenance

**⚠ WARNING**

**FIRE, EXPLOSION, OR CARBON MONOXIDE HAZARD.**

Failure to follow this warning could result in personal injury or death.

It is recommended that the furnace be inspected and serviced on an annual basis (before the heating season) by a qualified service technician.

**⚠ WARNING**

**ELECTRICAL SHOCK, FIRE OR EXPLOSION HAZARD.**

Failure to follow this warning could result in personal injury, death and/or property damage.

- Before servicing, disconnect all electrical power to furnace.
- When servicing controls, label all wires prior to disconnecting. Reconnect wires correctly.
- Verify proper operation after servicing.

See "User's Information Manual" and the "Service Manual".

# 11. Sequence of Operation & Diagnostics

---

The following is the normal operating sequence.

## Cooling (Y) Request:

24VAC signals applied to Y & G terminals of FCB (furnace control board)

- Cool motor speed is energized after 5 second Cool Fan On Delay time.

Y & G signals removed from FCB

- Cool motor speed is de-energized after 90 second Cool Fan Off Delay time.

## Continuous Circulating Fan (G) Request:

24 VAC signal is applied to G terminal of the FCB.

- Heat motor speed is energized without delay.

G signal removed from FCB.

- Heat motor speed is de-energized after 5 second delay.

NOTE 1) Furnace de-energizes the fan during the heat exchanger warm-up period on a call for Heating that occurs during a G request unless a blower motor lead is connected to the Cont terminal on the FCB, in which case see NOTE 2).

NOTE 2) Heating or Cooling requests received during a Fan request cause the fan speed to change to the appropriate heat or cool speed after the Fan on Delay time expires. The fan returns to continuous circulating speed after the selected Fan Off Delay time expires following loss of the Heating or Cooling request.

## Continuous Circulating Fan Hard-Wired (Cont) Request:

Field selected low speed motor tap installed on "CONT" terminal.

- Low speed is energized when power applied to furnace. Operates at this speed continuously while there are no other blower demands from furnace control. Fan demands from furnace control for heat, cool or "G" will override hard-wired speed tap.

NOTE 3) EAC is NOT active for hard-wired mode but IS active for fan demands from furnace control for heat, cool and "G".

## Heating (W) Request:

Heating (W) Request:

- 24 VAC signal applied to W terminal of FCB.
- Inducer motor turns on and the pressure switch(es) close(s).
- Following a 15 second prepurge delay, after the pressure switches closes, the igniter begins a 17 second warm-up.
- The gas valve is energized, the main burners light and flame is sensed.
- The igniter is de-energized after the main burners ignite.
- FCB will delay blower operation for the 30 seconds timed from the opening of the gas valve.

W signal removed from FCB.

- The gas valve de-energizes and the main burners go out.
- The inducer runs for a 15 second postpurge period.
- The fan stays at Heat speed.
- The fan de-energizes after the selected Heat Fan Off Delay time expires, timed from the gas valve de-energizing.

HUMIDIFIER - The 24V HUM is energized when the pressure switch closes on a call for heat. The 115V HUM (called HUM on Control) is energized when the inducer is energized.

ELECTRONIC AIR CLEANER - EAC is energized when there is a blower speed call. It is NOT energized when blower operates in the hard-wired continuous fan mode.

NOTE 4) If a new Heating request arrives while the control is waiting in the Heat Fan Off Delay time, the FCB will wait for the selected Heat Fan Off Delay then start a new heating cycle as long as the heat call remains.

## Heating Request with Gas Shut Off:

24 VAC signal applied to W terminal of FCB.

The FCB will attempt 4 cycles for ignition then go to soft lockout for 3 hours then try for ignition again as long as the heat call remains. Power reset will clear lockout.

- Inducer motor turns on
- Following a 15 second prepurge delay, the igniter begins warm up.
- The igniter glows red-hot for 22 seconds, then turns off. The FCB flashes error code 6.
- The igniter stays off for 17 seconds, then begins to warm up again.
- The igniter glows red hot for 22 seconds then turns off. The FCB continues flashing error code 6.
- The igniter stays off for 17 seconds, then begins to warm up again.
- The igniter glows red hot for 22 seconds then turns off. The FCB continues flashing error code 6.
- The igniter stays off for 17 seconds, then begins to warm up again.
- The igniter glows red hot for 22 seconds then turns off. The FCB proceeds to soft lockout and stops flashing error code 6 and begins flashing error code 6 + 1.
- The inducer motor de-energizes after a 15 second post purge.

## Control Board Diagnostic Codes (See Figure 54)

OFF	= 24VAC or 115VAC is off, fuse is open
Heartbeat	= Normal operation or no previous Diagnostic Code
ON SOLID	= Soft Lockout - Furnace Control Error (1 hr delay) If code repeats immediately following power reset then replace control
1 Flash	= Not used
2 Flashes	= Pressure switch(es) closed when should be open
3 Flashes	= Pressure switch open when should be closed
4 Flashes	= Limit or roll-out switch open (less than 2 minutes)
5 Flashes	= Flame sensed out of sequence
6 Flashes	= Failure to ignite or flame sense lost while running
6 + 1 Flashes	= Soft Lockout - Max trials for ignition reached (3 hr delay)
7 Flashes	= Soft Lockout - Limit or roll-out switch open longer than 2 minutes (1 hr delay) (roll-out switch requires manual reset)
8 Flashes	= Permanent Lockout - Gas valve relay contact stuck closed or miswired gas valve (power reset only)
10 Flashes	= Line voltage (115VAC) polarity reversed. If twinned, refer to twinning kit instructions

\* If status code recall is needed, briefly (2-3 seconds) remove then reconnect one limit switch wire (main or rollout) to display last stored status code. Do not remove power or blower door before initiating status code recall or code will be lost. Code is automatically cleared after 72 hours or upon power reset.

\* Proper flame sense microamps: 0.7 microamps D.C. minimum, 2.0 - 4.0 microamps nominal

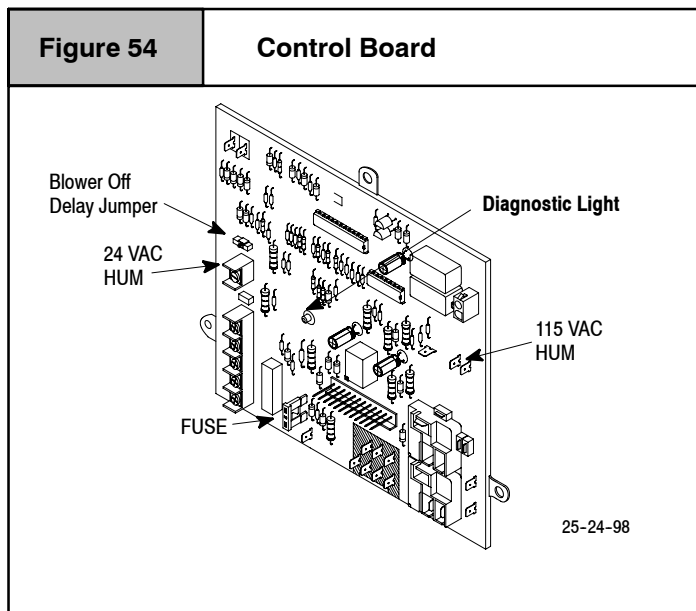

# Technical Support Manual

## Four Position Furnace

### Models

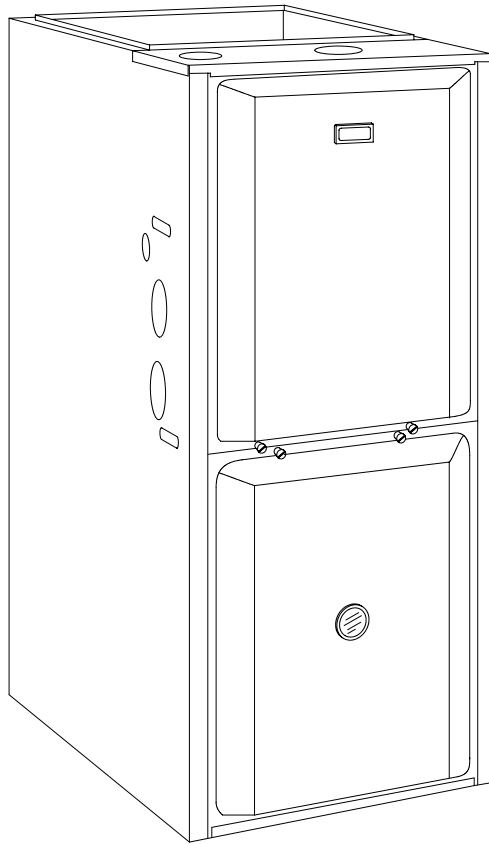

**Single Pipe**  
N9MP1040B08C2  
N9MP1050B12C2  
N9MP1060B12C2  
N9MP1075B12C2  
N9MP1080F16C2  
N9MP1100F14C2  
N9MP1100J20C2  
N9MP1125J20C2

or

**Two Pipe**  
N9MP2050B12C2  
N9MP2075B12C2  
N9MP2080F16C2  
N9MP2100F14C2  
N9MP2100J20C2  
N9MP2125J20C2

**Dual Certified**  
N9MPD040F08A2  
N9MPD050F12A2  
N9MPD060F12A2  
N9MPD075F12A2  
N9MPD080J16A2  
N9MPD100J14A2  
N9MPD100J20A2  
N9MPD125L20A2

or

**Dual Certified**  
\*9MPD050F12C2  
\*9MPD075F12C2  
\*9MPD080J16C2  
\*9MPD100J14C2  
\*9MPD100J20C2  
\*9MPD125L20C2

\* Denotes Brand



**International Comfort Products, LLC**  
Lewisburg, TN 37091 U.S.A.

**Save This Manual For Future Reference**

# Model Specifications

Manufacturers Number (Mfr No -See Rating Plate) ALL Models									
Specifications (N9MP1)									
	N9MP1040B08C		N9MP1050B12C		N9MP1060B12C		N9MP1075B12C		
<b>General</b>									
Gas Type	Nat./Propane		Nat./Propane		Nat./Propane		Nat./Propane		
Input (Btuh)	40,000		50,000		60,000		75,000		
Output (Btuh)	36,000		45,500		54,000		68,000		
Transformer Size (VA)	40		40		40		40		
T'stat Heat Anticipator	.50		.50		.50		.50		
Temp. Rise (°F/°C)	40-70/22-38		35-65/19-36		40-70/22-38		40-70/22-38		
Electrical (Volts/Hz/FLA)	115/60/5.0		115/60/9.8		115/60/7.2		115/60/8.9		
Rating Plate Amps	8.4		12.9		10.9		10.1		
<b>Gas &amp; Ignition</b>									
Gas Type	Nat.	Propane	Nat.	Propane	Nat.	Propane	Nat.	Propane	
Gas Valve (Honeywell)	VR 8205S								
Regulation Type	SNAP								
IgnitionType/Series	Hot Surface								
Manifold Press. (in wc)	3.5	10.0	3.5	10.0	3.5	10.0	3.5	10.0	
Std. Main Orifices (No/Size)	2/44	2/55	2/42	2/54	3/44	3/55	3/42	3/54	
<b>Furnace Controls</b>									
Furnace Control (Type)	Integrated								
Furnace Control	30								
(Timed-secs) On	60,100,140,180								
Off									
<b>Combustion</b>									
Flue Outlet Size (Inches)	2		2		2		2		
Std. Outlet Temp (less than) °5' No Elbows	140°F/77°C		140°F/77°C		140°F/77°C		140°F/77°C		
<b>Blower Pressure 5' No Elbows (in wc)</b>	-2.0		--		-1.45		--		
<b>Blower Pressure 40' +5-90° DWV Elbows (in wc)</b>	-1.85		--		-1.30		--		
<b>Transition Bx Pressure 5' No Elbows (in wc)</b>	-2.05		-2.6		-2.10		-2.6		
<b>Transition Bx Pressure 40' +5-90° DWV Elbows (in wc)</b>	-1.75		-2.3		-1.80		-2.3		
<b>Limits &amp; Controls</b>									
Rollout Switch (°F)	300		300		300		300		
Limit Control Setting (°F)	220		240		210		210		
Standard Pressure Sw. (Part No)	1175725		1013802		1175725		1013802		
Blower Switch Pressure (Close) (in wc)	-0.80		--		-0.80		--		
Blower Switch Pressure (Open) (in wc)	-0.65		--		-0.65		--		
Transition Switch Pressure (Close) (in wc)	-0.75		-2.2		-0.75		-2.2		
Transition Switch Pressure (Open) (in wc)	-0.60		-2.0		-0.60		-2.0		
High Altitude Pressure Sw. (Part No)	--		1013803		--		1013803		
Blower Switch Pressure (Close)(in wc)	--		--		--		--		
Blower Switch Pressure (Open)(in wc)	--		--		--		--		
Transition Switch Pressure (Close)(in wc)	--		-2.0		--		-2.0		
Transition Switch Pressure (Open) (in wc)	--		-1.8		--		-1.8		
Long Vent Kit (Part No)	--		--		--		--		
Pressure Switch (Part No)	--		--		--		--		
Blower Switch Pressure (Close)(in wc)	--		--		--		--		
Blower Switch Pressure (Open) (in wc)	--		--		--		--		
Transition Switch Pressure (Close) (in wc)	--		--		--		--		
Transition Switch Pressure (Open) (in wc)	--		--		--		--		
High Altitude Long Vent Kit (Part No)	--		--		--		--		
Pressure Switch (Part No)	--		--		--		--		
Blower Switch Pressure (Close) (in wc)	--		--		--		--		
Blower Switch Pressure (Open) (in wc)	--		--		--		--		
Transition Switch Pressure (Close) (in wc)	--		--		--		--		
Transition Switch Pressure (Open)(in wc)	--		--		--		--		
<b>Blower Data</b>									
Blower Size (D x W)	11-8		11-8		11-8		11-8		
Motor Amps/RPM	5.0/960		10.0/850		8.0/1050		8.0/1050		
Motor Type/H.P.	PSC/1/4		PSC/1/2		PSC/1/2		PSC/1/2		
Cap. Mfd/Volts	7.5/370		7.5/370		7.5/370		7.5/370		
Filter Type & Size (qty.) Permanent - not supplied	16x25x1		16x25x1		16x25x1		16x25x1		
Cool Cap. (Tons) @ .5 in wc L, ML, MHi & Hi	1 1/2,2		1 1/2,2,2 1/2,3		1 1/2,2,2 1/2,3		1 1/2,2,2 1/2,3		
<b>Gas Conversion Kits for 50k &amp; 75k</b>					<b>Gas Conversion Kits for 40k &amp; 60k</b>				
Nat to Propane	NAHA001LP (1172958*)				Nat to Propane	NAHA003LP (1174906*)			
Propane to Nat	NAHA001NG (1172960*)				Propane to Nat	NAHA004NG (1174907*)			
*Order from Service Parts					*Order from Service Parts				



# Model Specifications

Manufacturers Number (Mfr No -See Rating Plate) ALL Models									
Specifications (N9MP1)									
	N9MP1080F16C		N9MP1100F14C		N9MP1100J20C		N9MP1125J20C		
<b>General</b>									
Gas Type	Nat./Propane		Nat./Propane		Nat./Propane		Nat./Propane		
Input (Btuh)	80,000		100,000		100,000		125,000		
Output (Btuh)	72,000		91,000		96,500		113,750		
Transformer Size (VA)	40		40		40		40		
T'stat Heat Anticipator	.50		.50		.50		.50		
Temp. Rise (°F/°C)	35-65/19-36		40-70/22-38		40-70/22-38		40-70/22-38		
Electrical (Volts/Hz/FLA)	115/60/9.0		115/60/9.0		115/60/10.5		115/60/11.2		
Rating Plate Amps	12.9		10.1		14.4		15.0		
<b>Gas &amp; Ignition</b>									
Gas Type	Nat.	Propane	Nat.	Propane	Nat.	Propane	Nat.	Propane	
Gas Valve (Honeywell)	VR 8205S								
Regulation Type	SNAP								
IgnitionType/Series	Hot Surface								
Manifold Press. (in wc)	3.5	10.0	3.5	10.0	3.5	10.0	3.5	10.0	
Std. Main Orifices (No/Size)	4/44	4/55	4/42	4/54	4/42	4/54	5/42	5/54	
<b>Furnace Controls</b>									
Furnace Control (Type )	Integrated								
Furnace Control On	30								
(Timed-secs) Off	60,100,140,180								
<b>Combustion</b>									
Flue Outlet Size (Inches)	2		3		3		3		
Std. Outlet Temp (less than) °5' No Elbows	140°F/77°C		140°F/77°C		140°F/77°C		140°F/77°C		
<b>Blower Pressure 5' No Elbows (in wc)</b>									
Blower Pressure 40' +5-90° DWV Elbows (in wc)	--		-1.8		-1.8		-1.8		
Transition Bx Pressure 5' No Elbows (in wc)	-2.6		-2.6		-2.6		-2.6		
Transition Bx Pressure 40' +5-90° DWV Elbows (in wc)	-2.5		-2.5		-2.5		-2.5		
<b>Limits &amp; Controls</b>									
Rollout Switch (°F)	300		300		300		300		
Limit Control Setting (°F)	230		230		220		190		
<b>Standard Pressure Sw. (Part No)</b>									
Blower Switch Pressure (Close) (in wc)	1013811		1013801		1013802		1013166		
Blower Switch Pressure (Open) (in wc)	--		--		--		-1.3		
Transition Switch Pressure (Close) (in wc)	--		--		--		-1.1		
Transition Switch Pressure (Open) (in wc)	-1.8		-2.3		-2.2		-1.8		
Transition Switch Pressure (Open) (in wc)	-1.6		-2.1		-2.0		-1.6		
<b>High Altitude Pressure Sw. (Part No)</b>									
Blower Switch Pressure (Close)(in wc)	1013812		1013803		1013803		1013157		
Blower Switch Pressure (Open)(in wc)	--		--		--		-0.9		
Transition Switch Pressure (Close)(in wc)	--		--		--		-0.7		
Transition Switch Pressure (Open) (in wc)	-1.5		-2.0		-2.0		-1.7		
Transition Switch Pressure (Open) (in wc)	-1.3		-1.8		-1.8		-1.5		
<b>Long Vent Kit (Part No)</b>									
Pressure Switch (Part No)	--		NAHA001LV		NAHA001LV		--		
Blower Switch Pressure (Close)(in wc)	--		1013518		1013518		--		
Blower Switch Pressure (Open) (in wc)	--		-1.0		-1.0		--		
Transition Switch Pressure (Close) (in wc)	--		-0.8		-0.8		--		
Transition Switch Pressure (Open) (in wc)	--		-2.0		-2.0		--		
Transition Switch Pressure (Open) (in wc)	--		-1.8		-1.8		--		
<b>High Altitude Long Vent Kit (Part No)</b>									
Pressure Switch (Part No)	--		NAHA003LV		NAHA003LV		--		
Blower Switch Pressure (Close) (in wc)	--		1013165		1013165		--		
Blower Switch Pressure (Open) (in wc)	--		-0.7		-0.7		--		
Transition Switch Pressure (Close) (in wc)	--		-0.6		-0.6		--		
Transition Switch Pressure (Open) (in wc)	--		-1.4		-1.4		--		
Transition Switch Pressure (Open) (in wc)	--		-1.2		-1.2		--		
<b>Blower Data</b>									
Blower Size (D x W)	11-10		11-10		11-10		11-10		
Motor Amps/RPM	10/1050		10/1050		13/900		13/900		
Motor Type/H.P.	PSC/1/2		PSC/1/2		PSC <sup>β</sup> /4		PSC <sup>β</sup> /4		
Cap. Mfd/Volts	10/370		10/370		40/370		40/370		
Filter Type & Size (qty.) Permanent - not supplied	16x25x1		16x25x1		16x25x1 (2)		16x25x1 (2)		
Cool Cap. (Tons) @ .5 in wc L, ML, MHi & Hi	2 <sup>1</sup> / <sub>2</sub> ,3,3 <sup>1</sup> / <sub>2</sub> ,4		1 <sup>1</sup> / <sub>2</sub> ,2,3,3 <sup>1</sup> / <sub>2</sub> ,2		3 <sup>1</sup> / <sub>2</sub> ,4,4 <sup>1</sup> / <sub>2</sub> ,5		3 <sup>1</sup> / <sub>2</sub> ,4,4 <sup>1</sup> / <sub>2</sub> ,5		
<b>Gas Conversion Kits for 100k &amp; 125k</b>					<b>Gas Conversion Kits for 80k</b>				
Nat to Propane	NAHA001LP (1172958*)				Nat to Propane		NAHA003LP (1174906*)		
Propane to Nat	NAHA001NG (1172960*)				Propane to Nat		NAHA004NG (1174907*)*		
*Order from Service Parts					*Order from Service Parts				

Manufacturers Number (Mfr No -See Rating Plate) ALL Models													
Specifications (N9MP2)													
	N9MP2050B12C		N9MP2075B12C		N9MP2080F16C		N9MP2100F14C		N9MP2100J20C		N9MP2125J20C		
<b>General</b>													
Gas Type	Nat./Propane		Nat./Propane		Nat./Propane		Nat./Propane		Nat./Propane		Nat./Propane		
Input (Btuh)	50,000		75,000		80,000		100,000		100,000		125,000		
Output (Btuh)	45,500		68,000		72,000		91,000		96,500		113,750		
Transformer Size (VA)	40		40		40		40		40		40		
T'stat Heat Anticipator	.50		.50		.50		.50		.50		.50		
Temp. Rise (°F/°C)	35-65/19-36		40-70/22-38		35-65/19-36		40-70/22-38		40-70/22-38		40-70/22-38		
Electrical (Volts/Hz/FLA)	115/60/9.8		115/60/8.9		115/60/9.0		115/60/9.0		115/60/10.5		115/60/11.2		
Rating Plate Amps	12.9		10.1		12.9		10.1		14.4		15.0		
<b>Gas &amp; Ignition</b>													
Gas Type	Nat.	Propane	Nat.	Propane	Nat.	Propane	Nat.	Propane	Nat.	Propane	Nat.	Propane	
Gas Valve (Honeywell)	VR 8205S												
Regulation Type	SNAP												
IgnitionType/Series	Hot Surface												
Manifold Press. (in wc)	3.5	10.0	3.5	10.0	3.5	10.0	3.5	10.0	3.5	10.0	3.5	10.0	
Std. Main Orifices (No/Size)	2/42	2/54	3/42	3/54	4/44	4/55	4/42	4/54	4/42	4/54	5/42	5/54	
<b>Furnace Controls</b>													
Furnace Control (Type)	Integrated												
Furnace Control (Timed-secs)	30 60,100,140,180												
<b>Combustion</b>													
Flue Outlet Size (Inches)	2		2		2		3		3		3		
Std. Outlet Temp (less than) °5' No Elbows	140°F/77°C		140°F/77°C		140°F/77°C		140°F/77°C		140°F/77°C		140°F/77°C		
<b>Blower Pressure 5' No Elbows (in wc)</b>													
Blower Pressure 40' +5-90° DWV Elbows (in wc)	--		-1.8		--		-1.8		-1.8		-1.8		
Transition Bx Pressure 5' No Elbows (in wc)	-2.6		-2.6		-2.6		-2.6		-2.6		-2.6		
Transition Bx Pressure 40' +5-90° DWV Elbows (in wc)	-2.3		-2.3		-2.5		-2.5		-2.5		-2.5		
<b>Limits &amp; Controls</b>													
Rollout Switch (°F)	300		300		300		300		300		300		
Limit Control Setting (°F)	240		210		230		230		220		190		
<b>Standard Pressure Sw. (Part No)</b>													
Blower Switch Pressure (Close) (in wc)	1013802		1013801		1013811		1013801		1013802		1013166		
Blower Switch Pressure (Open) (in wc)	--		--		--		--		--		-1.3		
Transition Switch Pressure (Close) (in wc)	--		--		--		--		--		-1.1		
Transition Switch Pressure (Open) (in wc)	-2.2		-2.3		-1.8		-2.3		-2.2		-1.8		
Transition Switch Pressure (Open) (in wc)	-2.0		-2.1		-1.6		-2.1		-2.0		-1.6		
<b>High Altitude Pressure Sw. (Part No)</b>													
Blower Switch Pressure (Close) (in wc)	1013803		1013803		1013812		1013803		1013803		1013157		
Blower Switch Pressure (Open) (in wc)	--		--		--		--		--		-0.9		
Transition Switch Pressure (Close) (in wc)	--		--		--		--		--		-0.7		
Transition Switch Pressure (Open) (in wc)	-2.0		-2.0		-1.5		-2.0		-2.0		-1.7		
Transition Switch Pressure (Open) (in wc)	-1.8		-1.8		-1.3		-1.8		-1.8		-1.5		
<b>Long Vent Kit (Part No)</b>													
Pressure Switch (Part No)	--		NAHA001LV		--		NAHA001LV		NAHA001LV		--		
Blower Switch Pressure (Close) (in wc)	--		1013518		--		1013518		1013518		--		
Blower Switch Pressure (Open) (in wc)	--		--		--		--		--		--		
Transition Switch Pressure (Close) (in wc)	--		-1.0		--		-1.0		-1.0		--		
Transition Switch Pressure (Open) (in wc)	--		-0.8		--		-0.8		-0.8		--		
Transition Switch Pressure (Open) (in wc)	--		-2.0		--		-2.0		-2.0		--		
Transition Switch Pressure (Open) (in wc)	--		-1.8		--		-1.8		-1.8		--		
<b>High Altitude Long Vent Kit (Part No)</b>													
Pressure Switch (Part No)	--		NAHA003LV		--		NAHA003LV		NAHA003LV		--		
Blower Switch Pressure (Close) (in wc)	--		1013165		--		1013165		1013165		--		
Blower Switch Pressure (Open) (in wc)	--		--		--		--		--		--		
Transition Switch Pressure (Close) (in wc)	--		-0.7		--		-0.7		-0.7		--		
Transition Switch Pressure (Open) (in wc)	--		-0.6		--		-0.6		-0.6		--		
Transition Switch Pressure (Open) (in wc)	--		-1.4		--		-1.4		-1.4		--		
Transition Switch Pressure (Open) (in wc)	--		-1.2		--		-1.2		-1.2		--		
<b>Blower Data</b>													
Type & Size	11-8		11-8		11-10		11-10		11-10		11-10		
Motor Amps/Rpm	10/850		8.0/1050		10/1050		10/1050		13/900		13/900		
Motor Type/H.p.	PSC/1/2		PSC/1/2		PSC/1/2		PSC/1/2		PSC <sup>β</sup> /4		PSC <sup>β</sup> /4		
Cap. Mfd/Volts	7.5/370		7.5/370		10/370		10/370		40/370		40/370		
Filter Type & Size (qty.), Permanent - not supplied	16x25x1		16x25x1		16x25x1		16x25x1		16x25x1 (2)		16x25x1 (2)		
Cool Cap. (Tons) @ .5 in wc L, ML, MHi & Hi	1 <sup>1</sup> / <sub>2</sub> ,2,2 <sup>1</sup> / <sub>2</sub> ,3		1 <sup>1</sup> / <sub>2</sub> ,2,2 <sup>1</sup> / <sub>2</sub> ,3		2 <sup>1</sup> / <sub>2</sub> ,3,3 <sup>1</sup> / <sub>2</sub> ,4		1 <sup>1</sup> / <sub>2</sub> ,2,3,3 <sup>1</sup> / <sub>2</sub> ,4		3 <sup>1</sup> / <sub>2</sub> ,4,4 <sup>1</sup> / <sub>2</sub> ,5		3 <sup>1</sup> / <sub>2</sub> ,4,4 <sup>1</sup> / <sub>2</sub> ,5		
<b>Gas Conversion Kits for 50k, 75k, 100k &amp; 125k</b>							<b>Gas Conversion Kits for 80k</b>						
Nat to Propane	NAHA001LP (1172958*)						NAHA003LP (1174906*)						
Propane to Nat	NAHA001NG (1172960*)						NAHA004NG (1174907*)*						
*Order from Service Parts							*Order from Service Parts						

Manufacturers Number (Mfr No -See Rating Plate) ALL Models									
Specifications (N9MPD)									
	N9MPD040F12A		N9MPD050F12A		N9MPD060F12A		N9MPD075F12A		
<b>General</b>									
Gas Type	Nat./Propane		Nat./Propane		Nat./Propane		Nat./Propane		
Input (Btuh)	40,000		50,000		60,000		75,000		
Output (Btuh)	37,000		46,000		55,000		69,000		
Transformer Size (VA)	40		40		40		40		
T'stat Heat Anticipator	.50		.50		.50		.50		
Temp. Rise (°F/°C)	35-65/19-36		35-65/19-36		40-70/22-38		40-70/22-38		
Electrical (Volts/Hz)	115/60		115/60		115/60		115/60		
Rating Plate Amps	8.6		12.9		10.6		10.1		
<b>Gas &amp; Ignition</b>									
Gas Type	Nat.	Propane	Nat.	Propane	Nat.	Propane	Nat.	Propane	
Gas Valve (Honeywell)	VR 8205S								
Regulation Type	SNAP								
IgnitionType/Series	Hot Surface								
Manifold Press. (in wc)	3.5	10.0	3.5	10.0	3.5	10.0	3.5	10.0	
Std. Main Orifices (No/Size)	2/44	2/55	2/42	2/54	3/44	3/55	3/42	3/54	
<b>Furnace Controls</b>									
Furnace Control (Type)	Integrated								
Furnace Control On	30								
Furnace Control Off	60,100,140,180								
<b>Combustion</b>									
Flue Outlet Size (Inches)	2		2		2		2		
Std. Outlet Temp (less than) °5' No Elbows	140°F/77°C		140°F/77°C		140°F/77°C		140°F/77°C		
Blower Pressure 5' No Elbows (in wc)	-2.00		--		-1.90		--		
Blower Pressure 40' +5-90° DWV Elbows (in wc)	-1.90		--		-1.52		--		
Transition Bx Pressure 5' No Elbows (in wc)	-0.90		-2.6		-1.10		-2.6		
Transition Bx Pressure 40' +5-90° DWV Elbows (in wc)	-0.90		-2.3		-1.05		-2.3		
<b>Limits &amp; Controls</b>									
Rollout Switch (°F)	300		300		300		300		
Limit Control Setting (°F)	250		260		230		240		
<b>Standard Pressure Sw. (Part No)</b>									
Blower Switch Pressure (Close) (in wc)	1175818		1013802		1175726		1013802		
Blower Switch Pressure (Open) (in wc)	-1.24		--		-1.01		--		
Transition Switch Pressure (Close) (in wc)	-1.05		--		-0.86		--		
Transition Switch Pressure (Open) (in wc)	-0.70		-2.2		-0.65		-2.2		
Transition Switch Pressure (Open) (in wc)	-0.55		-2.0		-0.50		-2.0		
<b>High Altitude Pressure Sw. (Part No)</b>									
Blower Switch Pressure (Close) (in wc)	1175819		1013803		1175819		1013803		
Blower Switch Pressure (Open) (in wc)	-0.95		--		-0.95		--		
Transition Switch Pressure (Close) (in wc)	-0.80		--		-0.80		--		
Transition Switch Pressure (Open) (in wc)	-0.60		-2.0		-0.60		-2.0		
Transition Switch Pressure (Open) (in wc)	-0.45		-1.8		-0.45		-1.8		
<b>Long Vent Kit (Part No)</b>									
Pressure Switch (Part No)	--		--		--		--		
Blower Switch Pressure (Close) (in wc)	--		--		--		--		
Blower Switch Pressure (Open) (in wc)	--		--		--		--		
Transition Switch Pressure (Close) (in wc)	--		--		--		--		
Transition Switch Pressure (Open) (in wc)	--		--		--		--		
<b>High Altitude Long Vent Kit (Part No)</b>									
Pressure Switch (Part No)	--		--		--		--		
Blower Switch Pressure (Close) (in wc)	--		--		--		--		
Blower Switch Pressure (Open) (in wc)	--		--		--		--		
Transition Switch Pressure (Close) (in wc)	--		--		--		--		
Transition Switch Pressure (Open) (in wc)	--		--		--		--		
<b>Blower Data</b>									
Blower Size (D x W)	11-8		11-8		11-10		11-10		
Motor Amps/RPM	5.0/960		10.0/850		8.0/1050		8.0/1050		
Motor Type/H.P.	PSC/1/4		PSC/1/2		PSC/1/2		PSC/1/2		
Cap. Mfd/Volts	10.0/370		7.5/370		7.5/370		7.5/370		
Filter Type & Size (qty.) Permanent - not supplied	16x25x1		16x25x1		16x25x1		16x25x1		
Cool Cap. (Tons) @ .5 in wc L, ML, MHi & Hi	1 1/2,2		1 1/2,2,2 1/2,3		1 1/2,2,2 1/2,3		1 1/2,2,2 1/2,3		
<b>Gas Conversion Kits 50k &amp; 75k</b>					<b>Gas Conversion Kits for 40k &amp; 60k</b>				
Nat to Propane	NAHA001LP (1172958*)				Nat to Propane	NAHA003LP (1174906*)			
Propane to Nat	NAHA001NG (1172960*)				Propane to Nat	NAHA004NG (1174907*)*			
*Order from Service Parts					*Order from Service Parts				

Manufacturers Number (Mfr No -See Rating Plate) ALL Models									
Specifications (N9MPD)									
	N9MPD080J16A		N9MPD100J14A		N9MPD100J20A		N9MPD125L20A		
<b>General</b>									
Gas Type	Nat./Propane		Nat./Propane		Nat./Propane		Nat./Propane		
Input (Btuh)	80,000		100,000		100,000		125,000		
Output (Btuh)	73,600		92,000		92,000		115,000		
Transformer Size (VA)	40		40		40		40		
T'stat Heat Anticipator	.50		.50		.50		.50		
Temp. Rise (°F/°C)	35-65/19-36		40-70/22-38		40-70/22-38		40-70/22-38		
Electrical (Volts/Hz)	115/60		115/60		115/60		115/60		
Rating Plate Amps	12.9		10.1		14.4		15.0		
<b>Gas &amp; Ignition</b>									
Gas Type	Nat.	Propane	Nat.	Propane	Nat.	Propane	Nat.	Propane	
Gas Valve (Honeywell)	VR 8205S								
Regulation Type	SNAP								
IgnitionType/Series	Hot Surface								
Manifold Press. (in wc)	3.5	10.0	3.5	10.0	3.5	10.0	3.5	10.0	
Std. Main Orifices (No/Size)	4/44	4/55	4/42	4/54	4/42	4/54	5/42	5/54	
<b>Furnace Controls</b>									
Furnace Control (Type)	Integrated								
Furnace Control	30								
(Timed-secs) On	60,100,140,180								
Off									
<b>Combustion</b>									
Flue Outlet Size (Inches)	2		3		3		3		
Std. Outlet Temp (less than) °5' No Elbows	140°F/77°C		140°F/77°C		140°F/77°C		140°F/77°C		
<b>Blower Pressure 5' No Elbows (in wc)</b>									
Blower Pressure 40' +5-90° DWV Elbows (in wc)	--		-1.8		-1.8		-1.8		
Transition Bx Pressure 5' No Elbows (in wc)	--		-1.7		-1.7		-1.7		
Transition Bx Pressure 40' +5-90° DWV Elbows (in wc)	-2.6		-2.6		-2.6		-2.6		
Transition Bx Pressure 40' +5-90° DWV Elbows (in wc)	-2.5		-2.5		-2.5		-2.5		
<b>Limits &amp; Controls</b>									
Rollout Switch (°F)	300		300		300		300		
Limit Control Setting (°F)	220		220		220		190		
<b>Standard Pressure Sw. (Part No)</b>									
Blower Switch Pressure (Close) (in wc)	1013812		1013802		1013802		1013166		
Blower Switch Pressure (Open) (in wc)	--		--		--		-1.3		
Transition Switch Pressure (Close) (in wc)	--		--		--		-1.1		
Transition Switch Pressure (Open) (in wc)	-1.5		-2.2		-2.2		-1.8		
Transition Switch Pressure (Open) (in wc)	-1.3		-2.0		-2.0		-1.6		
<b>High Altitude Pressure Sw. (Part No)</b>									
Blower Switch Pressure (Close) (in wc)	1013813		1013803		1013803		1013157		
Blower Switch Pressure (Open) (in wc)	--		--		--		-0.9		
Transition Switch Pressure (Close) (in wc)	--		--		--		-0.7		
Transition Switch Pressure (Open) (in wc)	-1.2		-2.0		-2.0		-1.7		
Transition Switch Pressure (Open) (in wc)	-1.0		-1.8		-1.8		-1.5		
<b>Long Vent Kit (Part No)</b>									
Pressure Switch (Part No)	--		NAHA002LV		--		--		
Blower Switch Pressure (Close) (in wc)	--		1013515		--		--		
Blower Switch Pressure (Open) (in wc)	--		--		-1.0		--		
Transition Switch Pressure (Close) (in wc)	--		--		-0.8		--		
Transition Switch Pressure (Open) (in wc)	--		--		-1.7		--		
Transition Switch Pressure (Open) (in wc)	--		--		-1.5		--		
<b>High Altitude Long Vent Kit (Part No)</b>									
Pressure Switch (Part No)	--		NAHA003LV		--		--		
Blower Switch Pressure (Close) (in wc)	--		1013165		--		--		
Blower Switch Pressure (Open) (in wc)	--		--		-0.7		--		
Transition Switch Pressure (Close) (in wc)	--		--		-0.6		--		
Transition Switch Pressure (Open) (in wc)	--		--		-1.4		--		
Transition Switch Pressure (Open) (in wc)	--		--		-1.2		--		
<b>Blower Data</b>									
Type & Size	11-10		11-10		11-10		11-10		
Motor Amps/Rpm	10/1050		10/1050		13/900		13/900		
Motor Type/H.p.	PSC <sup>1</sup> / <sub>2</sub>		PSC <sup>1</sup> / <sub>2</sub>		PSC <sup>3</sup> / <sub>4</sub>		PSC <sup>3</sup> / <sub>4</sub>		
Cap. Mfd/Volts	10/370		10/370		40/370		40/370		
Filter Type & Size (qty.) Permanent - not supplied	16x25x1		16x25x1		16x25x1 (2)		16x25x1 (2)		
Cool Cap. (Tons) @ .5 in wc L, ML, MHi & Hi	2 <sup>1</sup> / <sub>2</sub> ,3,3 <sup>1</sup> / <sub>2</sub> ,4		1 <sup>1</sup> / <sub>2</sub> ,2,3,3 <sup>1</sup> / <sub>2</sub>		3 <sup>1</sup> / <sub>2</sub> ,4,4 <sup>1</sup> / <sub>2</sub> ,5		3 <sup>1</sup> / <sub>2</sub> ,4,4 <sup>1</sup> / <sub>2</sub> ,5		
<b>Gas Conversion Kits for 100k &amp; 125k</b>					<b>Gas Conversion Kits for 80k</b>				
Nat to Propane	NAHA001LP (1172958*)				Nat to Propane		NAHA003LP (1174906*)		
Propane to Nat	NAHA001NG (1172960*)				Propane to Nat		NAHA004NG (1174907*)*		
*Order from Service Parts					*Order from Service Parts				

Manufacturers Number (Mfr No -See Rating Plate) ALL Models													
Specifications (*9MPD)													
	*9MPD050F12C		*9MPD075F12C		*9MPD080J16C		*9MPD100J14C		*9MPD100J20C		*9MPD125L20C		
<b>General</b>													
Gas Type	Nat./Propane		Nat./Propane		Nat./Propane		Nat./Propane		Nat./Propane		Nat./Propane		
Input (Btuh)	50,000		75,000		80,000		100,000		100,000		125,000		
Output (Btuh)	46,000		69,000		73,600		92,000		92,000		115,000		
Transformer Size (VA)	40		40		40		40		40		40		
T'stat Heat Anticipator	.50		.50		.50		.50		.50		.50		
Temp. Rise (°F/°C)	35-65/19-36		40-70/22-38		35-65/19-36		40-70/22-38		40-70/22-38		40-70/22-38		
Electrical (Volts/Hz)	115/60		115/60		115/60		115/60		115/60		115/60		
Rating Plate Amps	12.9		10.1		12.9		10.1		14.4		15.0		
<b>Gas &amp; Ignition</b>													
Gas Type	Nat.	Propane	Nat.	Propane	Nat.	Propane	Nat.	Propane	Nat.	Propane	Nat.	Propane	
Gas Valve (Honeywell)	VR 8205S												
Regulation Type	SNAP												
IgnitionType/Series	Hot Surface												
Manifold Press. (in wc)	3.5	10.0	3.5	10.0	3.5	10.0	3.5	10.0	3.5	10.0	3.5	10.0	
Std. Main Orifices (No/Size)	2/42	2/54	3/42	3/54	4/44	4/55	4/42	4/54	4/42	4/54	5/42	5/54	
<b>Furnace Controls</b>													
Furnace Control (Type)	Integrated												
Furnace Control (Timed-secs)	30 60,100,140,180												
<b>Combustion</b>													
Flue Outlet Size (Inches)	2		2		2		3		3		3		
Std. Outlet Temp (less than) °5' No Elbows	140°F/77°C		140°F/77°C		140°F/77°C		140°F/77°C		140°F/77°C		140°F/77°C		
<b>Blower Pressure 5' No Elbows (in wc)</b>													
Blower Pressure 40' +5-90° DWV Elbows (in wc)	--		--		--		-1.8		-1.8		-1.8		
Transition Bx Pressure 5' No Elbows (in wc)	-2.6		-2.6		-2.6		-2.6		-2.6		-2.6		
Transition Bx Pressure 40' +5-90° DWV Elbows (in wc)	-2.3		-2.3		-2.5		-2.5		-2.5		-2.5		
<b>Limits &amp; Controls</b>													
Rollout Switch (°F)	300		300		300		300		300		300		
Limit Control Setting (°F)	260		240		220		220		220		190		
<b>Standard Pressure Sw. (Part No)</b>													
Blower Switch Pressure (Close) (in wc)	1013802		1013802		1013812		1013802		1013802		1013166		
Blower Switch Pressure (Open) (in wc)	--		--		--		--		--		-1.3		
Transition Switch Pressure (Close) (in wc)	--		--		--		--		--		-1.1		
Transition Switch Pressure (Open) (in wc)	-2.2		-2.2		-1.5		-2.2		-2.2		-1.8		
Transition Switch Pressure (Open) (in wc)	-2.0		-2.0		-1.3		-2.0		-2.0		-1.6		
<b>High Altitude Pressure Sw. (Part No)</b>													
Blower Switch Pressure (Close) (in wc)	1013803		1013803		1013813		1013803		1013803		1013157		
Blower Switch Pressure (Open) (in wc)	--		--		--		--		--		-0.9		
Transition Switch Pressure (Close) (in wc)	--		--		--		--		--		-0.7		
Transition Switch Pressure (Open) (in wc)	-2.0		-2.0		-1.2		-2.0		-2.0		-1.7		
Transition Switch Pressure (Open) (in wc)	-1.8		-1.8		-1.0		-1.8		-1.8		-1.5		
<b>Long Vent Kit (Part No)</b>													
Pressure Switch (Part No)	--		--		--		NAHA002LV		NAHA002LV		--		
Blower Switch Pressure (Close) (in wc)	--		--		--		1013515		1013515		--		
Blower Switch Pressure (Open) (in wc)	--		--		--		--		-1.0		--		
Transition Switch Pressure (Close) (in wc)	--		--		--		--		-0.8		--		
Transition Switch Pressure (Open) (in wc)	--		--		--		--		-1.7		--		
Transition Switch Pressure (Open) (in wc)	--		--		--		--		-1.5		--		
<b>High Altitude Long Vent Kit (Part No)</b>													
Pressure Switch (Part No)	--		--		--		NAHA003LV		NAHA003LV		--		
Blower Switch Pressure (Close) (in wc)	--		--		--		1013165		1013165		--		
Blower Switch Pressure (Open) (in wc)	--		--		--		--		-0.7		--		
Transition Switch Pressure (Close) (in wc)	--		--		--		--		-0.6		--		
Transition Switch Pressure (Open) (in wc)	--		--		--		--		-1.4		--		
Transition Switch Pressure (Open) (in wc)	--		--		--		--		-1.2		--		
<b>Blower Data</b>													
Blower Size inches (D x W)	11-8		11-10		11-10		11-10		11-10		11-10		
Motor Amps/RPM	10/850		8.0/1050		10/1050		10/1050		13/900		13/900		
Motor Type/H.P.	PSC/1/2		PSC/1/2		PSC/1/2		PSC/1/2		PSC <sup>β</sup> /4		PSC <sup>β</sup> /4		
Cap. Mfd/Volts	7.5/370		7.5/370		10/370		10/370		40/370		40/370		
Filter Type & Size (qty.) Permanent - not supplied	16x25x1		16x25x1		16x25x1		16x25x1		16x25x1 (2)		16x25x1 (2)		
Cool Cap. (Tons) @ .5 in wc L, ML, MHi & Hi	1 <sup>1</sup> / <sub>2</sub> ,2,2 <sup>1</sup> / <sub>2</sub> ,3		1 <sup>1</sup> / <sub>2</sub> ,2,2 <sup>1</sup> / <sub>2</sub> ,3		2 <sup>1</sup> / <sub>2</sub> ,3,3 <sup>1</sup> / <sub>2</sub> ,4		1 <sup>1</sup> / <sub>2</sub> ,2,3,3 <sup>1</sup> / <sub>2</sub>		3 <sup>1</sup> / <sub>2</sub> ,4,4 <sup>1</sup> / <sub>2</sub> ,5		3 <sup>1</sup> / <sub>2</sub> ,4,4 <sup>1</sup> / <sub>2</sub> ,5		
<b>Gas Conversion Kits for 50k, 75k, 100k &amp; 125k</b>							<b>Gas Conversion Kits for 80k</b>						
Nat to Propane	NAHA001LP (1172958*)						NAHA003LP (1174906*)						
Propane to Nat	NAHA001NG (1172960*)						NAHA004NG (1174907*)*						
*Order from Service Parts							*Order from Service Parts						

# CIRCULATION AIR BLOWER DATA (CFM#)

**N9MP1040B08 (1)(5)**

External Static Pressure (in wc)	Speed Tap	Low	Med L	Med H	Hi
	0.1	655	---	825	1009
	0.2	612	---	786	981
	0.3	560	---	744	944
	0.4	508	---	700	897
	0.5	457	---	647	841
	0.6	405	---	585	785
	0.7	343	---	519	719
	0.8	286	---	458	637
	0.9	204	---	382	561
	1.0	---	---	292	478

**N9MPD040F08 (1)(5)**

External Static Pressure (in wc)	Speed Tap	Low	Med L	Med H	Hi
	0.1	728	---	876	1079
	0.2	667	---	832	1032
	0.3	605	---	781	985
	0.4	541	---	725	933
	0.5	480	---	658	878
	0.6	421	---	593	802
	0.7	361	---	527	719
	0.8	294	---	461	634
	0.9	218	---	394	545
	1.0	---	---	317	462

**N9MP1050B12, N9MP2050B12 (1)(5)**

External Static Pressure (in wc)	Speed Tap	Low	Med L	Med H	Hi
	0.1	826	1083	1301	1408
	0.2	804	1050	1242	1347
	0.3	770	1028	1195	1295
	0.4	735	985	1153	1237
	0.5	698	952	1093	1183
	0.6	657	909	1040	1118
	0.7	---	863	935	1053
	0.8	---	812	865	976
	0.9	---	---	802	887
	1.0	---	---	720	787

**N9MPD050F12, \*9MPD050F12 (1)(5) \* Denotes Brand**

External Static Pressure (in wc)	Speed Tap	Low	Med L	Med H	Hi
	0.1	826	1083	1301	1408
	0.2	804	1050	1242	1347
	0.3	770	1028	1195	1295
	0.4	735	985	1153	1237
	0.5	698	952	1093	1183
	0.6	657	909	1040	1118
	0.7	---	863	935	1053
	0.8	---	812	865	976
	0.9	---	---	802	887
	1.0	---	---	720	787

**N9MP1060B12 (1)(5)**

External Static Pressure (in wc)	Speed Tap	Low	Med L	Med H	Hi
	0.1	706	895	1158	1439
	0.2	675	876	1137	1395
	0.3	640	850	1102	1345
	0.4	599	820	1066	1288
	0.5	569	786	1022	1228
	0.6	535	743	967	1159
	0.7	494	694	895	1080
	0.8	451	640	813	993
	0.9	399	585	730	894
	1.0	343	522	646	785

**N9MPD060F12 (1)(5)**

External Static Pressure (in wc)	Speed Tap	Low	Med L	Med H	Hi
	0.1	765	966	1247	1509
	0.2	708	919	1205	1453
	0.3	659	877	1155	1386
	0.4	612	828	1102	1313
	0.5	656	780	1037	1230
	0.6	522	728	986	1148
	0.7	452	674	909	1050
	0.8	403	609	835	953
	0.9	338	535	749	860
	1.0	255	455	653	748

- NOTE: (1) Data Based on Bottom Only or One Side return.  
 (2) Data Based on Both Sides or Bottom plus One Side.  
 (3) 100J20 Reduce airflow by 5% if Bottom Only return.  
 (4) 125J20 Reduce airflow by 5% if Bottom Only return.  
 (5) Gray area is above maximum temperature rise range.

# CFM - Cubic Feet Per Minute airflow. Filter required for each return-air inlet.  
 Airflow performance includes 1" washable (600 FPM max) filter media.  
 Disposable filters are typically rated at 300 FPM and only allow half of the airflow when compared to 600 FPM filters.  
 Example 20 x 25 @600 FPM = 2000 CFM, @300 FPM = 1000 CFM.

MAX CFM's for Factory Washable Filters	
Filter Size	CFM
14" X 25"	1400
16" X 25"	1600
20" X 25"	2000
24" X 25"	2500
Max CFM based on 600 FPM	

**N9MP1075B12, N9MP2075B12 (1)(5)**

External Static Pressure (in wc)	Speed Tap	Low	Med L	Med H	Hi
	0.1	706	917	1163	1368
	0.2	677	875	1120	1319
	0.3	636	840	1076	1263
	0.4	595	812	1031	1202
	0.5	546	766	987	1148
	0.6	490	702	889	1077
	0.7	---	630	821	989
	0.8	---	550	750	914
	0.9	---	462	676	833
	1.0	---	---	601	747

**N9MPD075F12, \*9MPD075F12 (1)(5) \* Denotes Brand**

External Static Pressure (in wc)	Speed Tap	Low	Med L	Med H	Hi
	0.1	706	917	1163	1368
	0.2	677	875	1120	1319
	0.3	636	840	1076	1263
	0.4	595	812	1031	1202
	0.5	546	766	987	1148
	0.6	490	702	889	1077
	0.7	---	630	821	989
	0.8	---	550	750	914
	0.9	---	462	676	833
	1.0	---	---	601	747

**N9MP1080F16, N9MP2080F16 (1)(5)**

External Static Pressure (in wc)	Speed Tap	Low	Med L	Med H	Hi
	0.1	823	1109	1527	1850
	0.2	795	1087	1482	1791
	0.3	747	1056	1426	1720
	0.4	677	1016	1382	1648
	0.5	617	970	1317	1575
	0.6	544	854	1245	1485
	0.7	---	763	1154	1401
	0.8	---	652	1043	1284
	0.9	---	---	905	1161
	1.0	---	---	737	1028

**N9MPD080J16, \*9MPD080J16 (1)(5) \* Denote Brand**

External Static Pressure (in wc)	Speed Tap	Low	Med L	Med H	Hi
	0.1	823	1109	1527	1850
	0.2	795	1087	1482	1791
	0.3	747	1056	1426	1720
	0.4	677	1016	1382	1648
	0.5	617	970	1317	1575
	0.6	544	854	1245	1485
	0.7	---	763	1154	1401
	0.8	---	652	1043	1284
	0.9	---	---	905	1161
	1.0	---	---	737	1028

**N9MP1100F14, N9MP2100F14 (1)(5)**

External Static Pressure (in wc)	Speed Tap	Low	Med L	Med H	Hi
	0.1	700	912	1209	1550
	0.2	660	884	1171	1492
	0.3	616	843	1139	1434
	0.4	575	790	1088	1378
	0.5	528	735	1040	1317
	0.6	472	677	979	1247
	0.7	---	608	909	1161
	0.8	---	528	827	1058
	0.9	---	---	733	932
	1.0	---	---	624	778

**N9MPD100J14, \*9MPD100J14 (1)(5) \* Denotes Brand**

External Static Pressure (in wc)	Speed Tap	Low	Med L	Med H	Hi
	0.1	700	912	1209	1550
	0.2	660	884	1171	1492
	0.3	616	843	1139	1434
	0.4	575	790	1088	1378
	0.5	528	735	1040	1317
	0.6	472	677	979	1247
	0.7	---	608	909	1161
	0.8	---	528	827	1058
	0.9	---	---	733	932
	1.0	---	---	624	778

- NOTE: (1) Data Based on Bottom Only or One Side return.  
 (2) Data Based on Both Sides or Bottom plus One Side.  
 (3) 100J20 Reduce airflow by 5% if Bottom Only return.  
 (4) 125J20 Reduce airflow by 5% if Bottom Only return.  
 (5) Gray area is above maximum temperature rise range.

# CFM - Cubic Feet Per Minute airflow. Filter required for each return-air inlet.  
 Airflow performance includes 1" washable (600 FPM max) filter media.  
 Disposable filters are typically rated at 300 FPM and only allow half of the airflow when compared to 600 FPM filters.  
 Example 20 x 25 @600 FPM = 2000 CFM, @300 PFM = 1000 CFM.

MAX CFM's for Factory Washable Filters	
Filter Size	CFM
14" X 25"	1400
16" X 25"	1600
20" X 25"	2000
24" X 25"	2500
Max CFM based on 600 FPM	

External Static Pressure (in wc)	Speed Tap	Low	Med L	Med H	Hi
	0.1	1720	1910	2127	2315
	0.2	1686	1881	2087	2268
	0.3	1644	1833	2024	2201
	0.4	1600	1777	1961	2131
	0.5	1533	1720	1891	2029
	0.6	1494	1647	1804	1948
	0.7	1413	1571	1708	1820
	0.8	1306	1470	1604	1730
	0.9	----	1349	1484	1614
	1.0	----	----	1328	1430

External Static Pressure (in wc)	Speed Tap	Low	Med L	Med H	Hi
	0.1	1720	1910	2127	2315
	0.2	1686	1881	2087	2268
	0.3	1644	1833	2024	2201
	0.4	1600	1777	1961	2131
	0.5	1533	1720	1891	2029
	0.6	1494	1647	1804	1948
	0.7	1413	1571	1708	1820
	0.8	1306	1470	1604	1730
	0.9	----	1349	1484	1614
	1.0	----	----	1328	1430

- NOTE:
- (1) Data Based on Bottom Only or One Side return.
  - (2) Data Based on Both Sides or Bottom plus One Side.
  - (3) 100J20 Reduce airflow by 5% if Bottom Only return.
  - (4) 125J20 Reduce airflow by 5% if Bottom Only return.
  - (5) Gray area is above maximum temperature rise range.

MAX CFM's for Factory Washable Filters	
Filter Size	CFM
14" X 25"	1400
16" X 25"	1600
20" X 25"	2000
24" X 25"	2500
Max CFM based on 600 FPM	

# CFM - Cubic Feet Per Minute airflow. Filter required for each return-air inlet. Airflow performance includes 1" washable (600 FPM max) filter media. Disposable filters are typically rated at 300 FPM and only allow half of the airflow when compared to 600 FPM filters. Example 20 x 25 @600 FPM = 2000 CFM, @300 PFM = 1000 CFM.



# Wiring Diagram (Single Stage, PSC Blower Motor)

COOL ON DELAY: 5 SEC  
 COOL OFF DELAY: 90 SEC  
 HEAT ON DELAY: 30 SEC

EAC + HUM 1.0A MAX  
 COMBINED

## FURNACE CONTROL J1

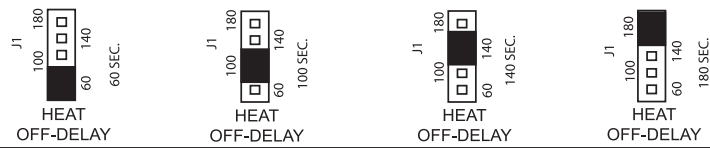

## LADDER DIAGRAM

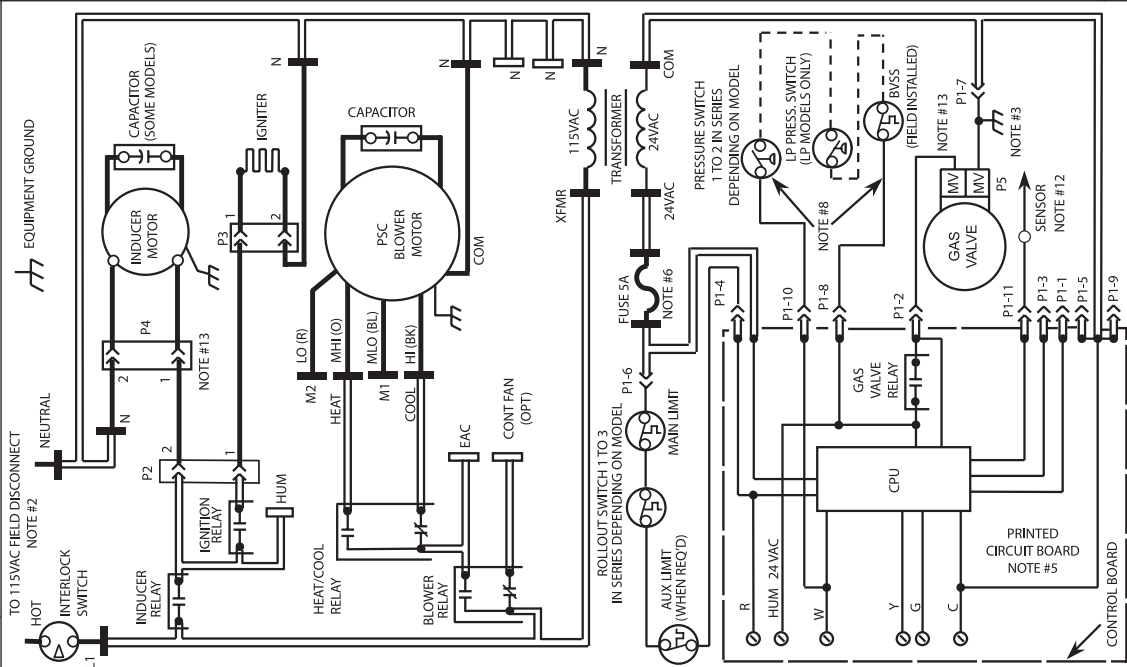

## CONNECTION DIAGRAM

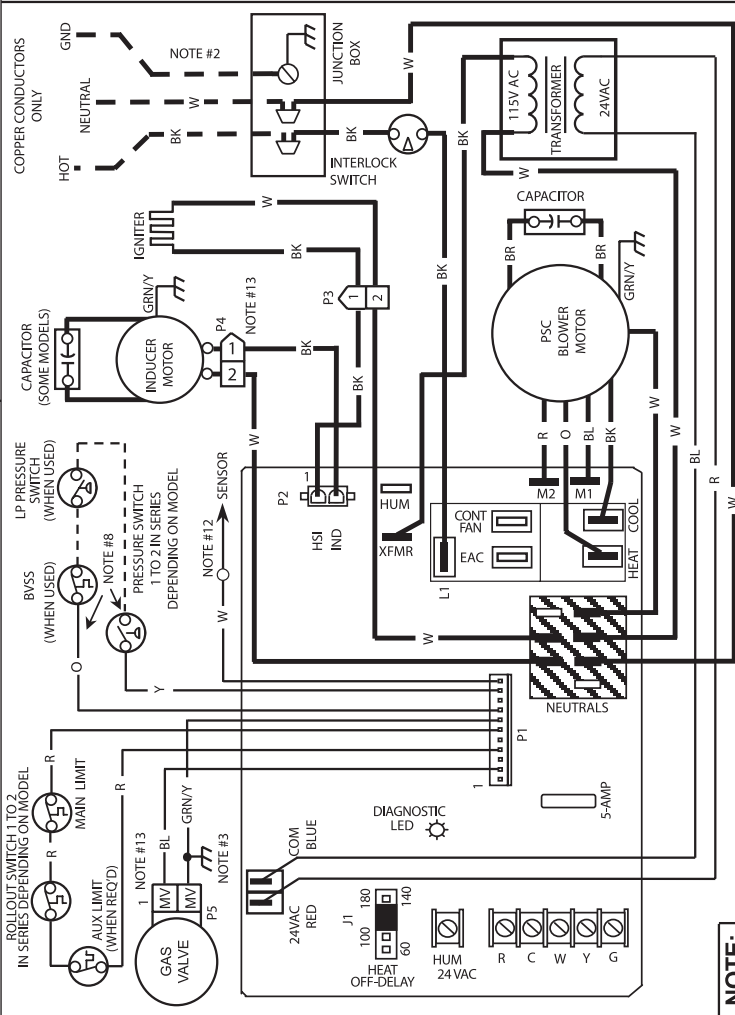

**WARNING: ELECTRICAL SHOCK HAZARD DISCONNECT BEFORE SERVICING**

COPPER CONDUCTORS ONLY

**SPEED TAP CODE**

BLACK	HI
BROWN	MHI
GREEN/YELLOW	MLO
ORANGE	LO
RED	

**COLOR CODE**

BK	
BL	
BR	
GRN/Y	
O	
R	
W	
Y	

**LOW VOLTAGE FACTORY**

- LOW VOLTAGE FIELD
- - - LINE VOLTAGE FACTORY
- · - LINE VOLTAGE FIELD
- · · CONDUCTOR ON CONTROL
- JUNCTION
- UNMARKED TERMINAL
- CONTROL TERMINAL

- NOTE:**
- If any of the original equipment wire is replaced use wire rated 105° C. Use only copper wire between the disconnect switch and the furnace junction box.
  - This wire must be connected to furnace sheet metal for control to prove flame.
  - Symbols are electrical representation only.
  - Solid lines inside circuit board are printed circuit board traces and are not depicted as shown in the legend.
  - Replace only with a 5 amp fuse.
  - Blower motor speed selections are for average conditions, see installation instructions for details on optimum speed selection.
  - Factory connected when LP Pressure Switch and BVSS (Chimney Adapter Accessory Kit) are not installed.
  - Blower off-delay, gas heating selections are (60, 100, 140, and 180) seconds, cooling or heat pump 90 seconds.
  - Ignition lockout will occur after four consecutive unsuccessful trials for ignition. Control will auto-reset after three hours.
  - Blower motor and inducer motor contain internal auto-reset thermal overload switches.
  - Flame sensor: 0.7 µA D.C. minimum, 2.0 - 4.0 µA nominal.
  - Depending on model, P4 inducer motor leads and P5 gas valve leads may be in a single connector or two quick connectors.

333309-101 REV. B

# N9MP1, N9MP2, N9MPD or \*9MPD

25-25-59

Representative drawing only, some models may vary in appearance.

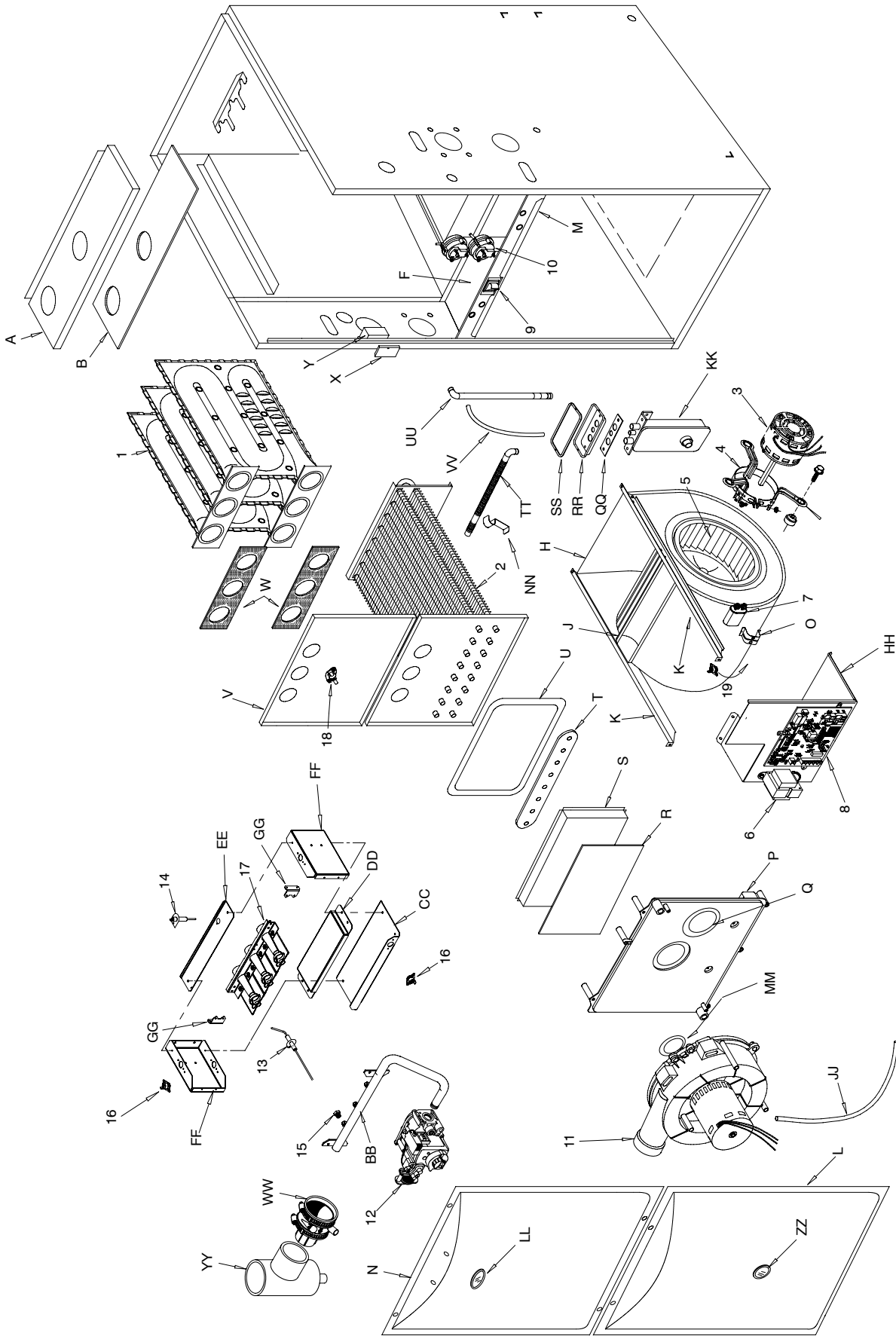

## Replacement Parts - N9MP1 & N9MP2

**Models** - N9MP1040B08C2, N9MP1050B12C2, N9MP1060B12C2, N9MP1075B12C2, N9MP1080F16C2, N9MP1100F14C2, N9MP1100J20C2 & N9MP1125J20C2 - N9MP2050B12C2, N9MP2075B12C2, N9MP2080F16C2, N9MP2100F14C2, N9MP2100J20C2 & N9MP2125J20C2 (Natural Gas)

**Replacement part supplied will be current active part. For parts not listed, consult place of purchase.**

Key No.	Description Functional	Part Number	N9MP1								N9MP2								
			040B 08C	050B 12C	060B 12C	075B 12C	080F 16C	100F 14C	100J 20C	125J 20C	050B 12C	075B 12C	080F 16C	100F 14C	100J 20C	125J 20C			
1	Heat Exchanger, Primary	1012847	1	1	-	-	-	-	-	-	-	-	1	-	-	-	-	-	
		1012851	-	-	1	1	-	-	-	-	-	-	-	1	-	-	-	-	-
		1012855	-	-	-	-	1	1	-	-	-	-	-	-	1	1	-	-	-
		1012856	-	-	-	-	-	-	-	1	-	1	-	-	-	-	1	-	-
		1012859	-	-	-	-	-	-	-	-	-	1	-	-	-	-	-	-	1
2	Heat Exchanger, Secondary	1013760	1	1	-	-	-	-	-	-	-	-	1	-	-	-	-	-	
		1013761	-	-	1	1	-	-	-	-	-	-	-	1	-	-	-	-	-
		1013764	-	-	-	-	1	1	-	-	-	-	-	-	1	1	-	-	-
		1013765	-	-	-	-	-	-	-	1	-	1	-	-	-	-	1	-	-
		1013766	-	-	-	-	-	-	-	-	-	-	1	-	-	-	-	-	1
3	Motor, Blr 1/115 1/4 CCW 1/115 1/2 CCW 1/115 1/2 CCW 1/115 3/4 CCW	1175724	1	-	-	-	-	-	-	-	-	-	-	-	-	-	-	-	
		1172488	-	1	-	-	1	-	-	-	-	-	1	-	1	-	-	-	-
		1172487	-	-	1	1	-	-	1	-	-	-	-	1	-	-	-	-	-
		1172489	-	-	-	-	-	-	-	-	1	1	-	-	-	-	1	1	-
4	Mount, Motor kit*	1014824	1	1	1	1	-	-	-	-	-	-	1	1	-	-	-	-	
		1014823	-	-	-	-	1	-	1	1	1	-	-	-	1	-	1	1	1
		1014822	-	-	-	-	-	-	1	-	-	-	-	-	-	1	-	-	-
5	Wheel, Blower	1013011	1	1	-	1	-	-	-	-	-	-	1	1	-	-	-	-	
		1011420	-	-	1	-	1	1	1	1	1	1	-	-	1	1	1	1	1
6	Transformer	1172810	1	1	1	1	1	1	1	1	1	1	1	1	1	1	1	1	
7	Capacitor, 10Mfd, 370V 7.5Mfd., 370V 40Mfd., 370V	1171729	-	1	-	-	1	-	-	-	-	-	1	-	1	-	-	-	
		1171728	1	-	1	1	-	1	-	-	-	-	-	1	-	1	-	-	-
		1171982	-	-	-	-	-	-	-	1	1	1	-	-	-	-	1	1	1
8	Control	1172550	1	1	1	1	1	1	1	1	1	1	1	1	1	1	1	1	
9	Switch, Interlock	1171981	1	1	1	1	1	1	1	1	1	1	1	1	1	1	1	1	
10	Switch, Pressure	1175725	1	-	1	-	-	-	-	-	-	-	-	-	-	-	-	-	-
		1013802	-	1	-	1	-	-	-	1	-	-	-	1	-	-	-	1	-
		1013811	-	-	-	-	-	1	-	-	-	-	-	-	1	-	-	-	-
		1013801	-	-	-	-	-	-	1	-	-	-	-	-	1	-	-	-	-
		1013166	-	-	-	-	-	-	-	-	-	-	1	-	-	-	-	-	1
11	Blower, Exhaust (Jakel)	1172823	1	1	1	1	1	1	1	1	-	1	1	1	1	1	1	-	
		1172824	-	-	-	-	-	-	-	-	-	1	-	-	-	-	-	-	1
12	Valve, Gas	1175705	1	1	1	1	1	1	1	1	1	1	1	1	1	1	1	1	
13	Flame Sensor	1172827	1	1	1	1	1	1	1	1	1	1	1	1	1	1	1	1	
14	Igniter	1172533	1	1	1	1	1	1	1	1	1	1	1	1	1	1	1	1	
15	Orifice, Burner #42 Nat. #44 Nat.	1011351	-	2	-	3	-	4	4	4	5	2	3	-	4	4	4	5	
		1011352	2	-	3	-	4	-	-	-	-	-	-	-	4	-	-	-	-
16	Switch, Limit (Rollout)	1013102	2	2	2	2	2	2	2	2	2	2	2	2	2	2	2	2	
17	Burner Assembly	1172847	1	1	-	-	-	-	-	-	-	-	1	-	-	-	-	-	
		1172965	-	-	1	1	-	-	-	-	-	-	-	1	-	-	-	-	-
		1172966	-	-	-	-	1	1	1	1	-	-	-	-	1	1	1	1	-
		1172967	-	-	-	-	-	-	-	-	-	1	-	-	-	-	-	-	1
18	Switch, Limit (Main)	34335001	-	-	-	1	-	-	-	-	-	-	-	1	-	-	-	-	
		34335002	-	1	-	-	-	-	-	-	-	-	-	1	-	-	-	-	-
		34335000	-	-	-	-	-	-	-	-	-	-	-	-	-	-	-	-	-
		1320361	1	-	-	-	1	1	-	-	-	-	-	-	1	1	-	-	-
		1008445	-	-	1	-	-	-	-	-	-	1	-	-	-	-	-	-	1
		1320361	-	-	-	-	-	-	-	1	-	-	-	-	-	-	1	-	-
19	Switch, Auxilliary	34335000	-	-	1	-	-	-	-	-	-	-	-	-	-	-	-	-	

\*See Table below for bellyband location on motor

Bellyband Location on Motor	
Model N9MP1/2	A(in.)
040B08C2	1.65"
050B12C2	2.09"
060B12C2	1.36"
075B12C2	1.38"

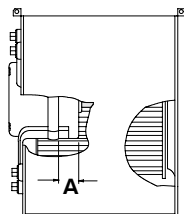

Bellyband Location on Motor	
Model N9MP1/2	A(in.)
080F16C2	1.81"
100F14C2	1.38"
100J20C2	1.65"
125J20C2	1.65"

## Replacement Parts - N9MP1 & N9MP2

**Models** - N9MP1040B08C2, N9MP1050B12C2, N9MP1060B12C2, N9MP1075B12C2, N9MP1080F16C2, N9MP1100F14C2, N9MP1100J20C2 & N9MP1125J20C2 - N9MP2050B12C2, N9MP2075B12C2, N9MP2080F16C2, N9MP2100F14C2, N9MP2100J20C2 & N9MP2125J20C2 (Natural Gas)

**Replacement part supplied will be current active part. For parts not listed, consult place of purchase.**

Key No.	Description Non- Functional	Part Number	N9MP1								N9MP2					
			040B 12C	050B 12C	060B 12C	075B 12C	080F 16C	100F 14C	100J 20C	125J 20C	050B 12C	075B 12C	080F 16C	100F 14C	100J 20C	125J 20C
A	Panel, Top	1013507	1	1	1	1	-	-	-	-	-	-	-	-	-	-
		1013508	-	-	-	-	1	1	-	-	-	-	-	-	-	-
		1013509	-	-	-	-	-	-	1	1	-	-	-	-	-	-
		1012957	-	-	-	-	-	-	-	-	-	1	1	-	-	-
		1012958	-	-	-	-	-	-	-	-	-	-	-	1	1	-
		1012959	-	-	-	-	-	-	-	-	-	-	-	-	-	1
B	Gasket, Top Panel	1012602	1	1	1	1	-	-	-	-	1	1	-	-	-	-
		1012603	-	-	-	-	1	1	-	-	-	-	1	1	-	-
		1012604	-	-	-	-	-	-	1	1	-	-	-	-	1	1
F	Partition, Blower	1171983	1	1	1	1	-	-	-	-	-	-	-	-	-	-
		1171984	-	-	-	-	1	1	-	-	-	-	-	-	-	-
		1171985	-	-	-	-	-	-	1	1	-	-	-	-	-	-
		1172004	-	-	-	-	-	-	-	-	-	1	1	-	-	-
		1172005	-	-	-	-	-	-	-	-	-	-	-	1	1	-
		1172006	-	-	-	-	-	-	-	-	-	-	-	-	-	1
H	Housing, Blower	1172885	1	1	-	1	-	-	-	-	1	1	-	-	-	-
		1172969	-	-	-	-	1	1	1	1	-	-	1	1	1	1
		1175827	-	-	1	-	-	-	-	-	-	-	-	-	-	-
		1175827			1											
J	Panel, Blower Cutoff	721020013	1	1	1	1	-	-	-	-	1	1	-	-	-	-
		721020008	-	-	-	-	1	1	1	1	-	-	1	1	1	1
K	Hanger, Blower	1012328	2	2	2	2	2	2	2	2	2	2	2	2	2	2
L	Door, Blower	1172992	1	1	1	1	-	-	-	-	-	-	-	-	-	-
		1172994	-	-	-	-	1	1	-	-	-	-	-	-	-	-
		1172996	-	-	-	-	-	-	1	1	-	-	-	-	-	-
		1172991	-	-	-	-	-	-	-	-	-	1	1	-	-	-
		1172993	-	-	-	-	-	-	-	-	-	-	-	1	1	-
		1172995	-	-	-	-	-	-	-	-	-	-	-	-	-	1
M	Bracket, Door Filler	1172231	1	1	1	1	-	-	-	-	1	1	-	-	-	-
		1172232	-	-	-	-	1	1	-	-	-	-	1	1	-	-
		1172233	-	-	-	-	-	-	1	1	-	-	-	-	1	1
N	Door, Front	1013789	1	1	1	1	-	-	-	-	-	-	-	-	-	-
		1013790	-	-	-	-	1	1	-	-	-	-	-	-	-	-
		1013791	-	-	-	-	-	-	1	1	-	-	-	-	-	-
		1013210	-	-	-	-	-	-	-	-	-	1	1	-	-	-
		1013211	-	-	-	-	-	-	-	-	-	-	-	1	1	-
		1013212	-	-	-	-	-	-	-	-	-	-	-	-	-	1
O	Strap, Capacitor	1170643	1	1	1	1	1	1	-	-	1	1	1	1	-	-
		1014315	-	-	-	-	-	-	1	1	-	-	-	-	1	1
P	Transition Assembly	1172227	1	1	1	1	-	-	-	-	1	1	-	-	-	-
		1172228	-	-	-	-	1	1	-	-	-	-	1	1	-	-
		1172229	-	-	-	-	-	-	1	1	-	-	-	-	1	1
Q	Gasket, Blower	1014425	1	1	1	1	1	1	1	1	1	1	1	1	1	1
R	Board, Insulating	1012417	1	1	1	1	-	-	-	-	1	1	-	-	-	-
		1012418	-	-	-	-	1	1	-	-	-	-	1	1	-	-
		1012419	-	-	-	-	-	-	1	1	-	-	-	-	1	1
S	Box, Collector	1012128	1	1	1	1	-	-	-	-	1	1	-	-	-	-
		1012244	-	-	-	-	1	1	-	-	-	-	1	1	-	-
		1012245	-	-	-	-	-	-	1	1	-	-	-	-	1	1
T	Gasket, Transition	1013079	1	1	1	1	-	-	-	-	1	1	-	-	-	-
		1013080	-	-	-	-	1	1	-	-	-	-	1	1	-	-
		1013083	-	-	-	-	-	-	1	1	-	-	-	-	1	1
U	Gasket, Collector Box	1012593	1	1	1	1	-	-	-	-	1	1	-	-	-	-
		1012594	-	-	-	-	1	1	-	-	-	-	1	1	-	-
		1012595	-	-	-	-	-	-	1	1	-	-	-	-	1	1
V	Partition, Front Ht Exchanger	1012646	1	1	-	-	-	-	-	-	1	-	-	-	-	-
		1012647	-	-	1	1	-	-	-	-	-	1	-	-	-	-
		1012649	-	-	-	-	1	1	-	-	-	-	1	1	-	-
		1012651	-	-	-	-	-	-	1	-	-	-	-	-	1	-
		1012652	-	-	-	-	-	-	-	1	-	-	-	-	-	1

## Replacement Parts - N9MP1 & N9MP2

**Models** - N9MP1040B08C2, N9MP1050B12C2, N9MP1060B12C2, N9MP1075B12C2, N9MP1080F16C2, N9MP1100F14C2, N9MP1100J20C2 & N9MP1125J20C2 - N9MP2050B12C2, N9MP2075B12C2, N9MP2080F16C2, N9MP2100F14C2, N9MP2100J20C2 & N9MP2125J20C2 (Natural Gas)

**Replacement part supplied will be current active part. For parts not listed, consult place of purchase.**

Key No.	Description Non- Functional	Part Number	N9MP1								N9MP2					
			040B 08C	050B 12C	060B 12C	075B 12C	080F 16C	100F 14C	100J 20C	125J 20C	050B 12C	075B 12C	080F 16C	100F 14C	100J 20C	125J 20C
W	Gasket, Attachment Plate	1012542	2	2	-	-	-	-	-	-	-	2	-	-	-	-
		1012543	-	-	2	2	-	-	-	-	-	-	2	-	-	-
		1012544	-	-	-	-	2	2	2	2	-	-	-	2	2	-
		1012545	-	-	-	-	-	-	-	-	2	-	-	-	-	2
X	Cover, Junction Box	1012350	1	1	1	1	1	1	1	1	1	1	1	1	1	
Y	Box, Junction	1172860	1	1	1	1	1	1	1	1	1	1	1	1	1	
BB	Manifold	1012276	1	1	-	-	-	-	-	-	-	1	-	-	-	-
		1012277	-	-	1	1	-	-	-	-	-	-	1	-	-	-
		1012278	-	-	-	-	1	1	1	-	-	-	-	1	1	1
		1012279	-	-	-	-	-	-	-	1	-	-	-	-	-	1
CC	Bottom, Burner Box	1172847	1	1	-	-	-	-	-	-	-	1	1	-	-	-
		1172848	-	-	1	1	-	-	-	-	-	-	-	1	1	-
		1172849	-	-	-	-	1	1	1	-	-	-	-	-	-	1
		1172850	-	-	-	-	-	-	-	1	-	-	-	-	-	-
DD	Baffle, Burner Box	1012338	1	1	1	1	-	-	-	-	1	1	-	-	-	-
		1012339	-	-	-	-	1	1	1	-	-	-	1	1	1	-
		1012340	-	-	-	-	-	-	-	1	-	-	-	-	-	1
EE	Top, Burner Box	1013702	1	1	1	1	-	-	-	-	1	1	-	-	-	-
		1013703	-	-	-	-	1	1	1	-	-	-	1	1	1	-
		1013704	-	-	-	-	-	-	-	1	-	-	-	-	-	1
FF	Bracket, Manifold Support	1012377	2	2	2	2	2	2	2	2	2	2	2	2	2	
GG	Bracket, Burner Box Side	1012532	2	2	2	2	2	2	2	2	2	2	2	2	2	
HH	Bracket, Control Mounting	1172845	1	1	1	1	1	1	1	1	1	1	1	1	1	
JJ	Tube, Sensor	1172240	1	1	1	1	1	1	1	-	1	1	1	1	1	1
		1172238	-	-	-	-	-	-	-	1	-	-	-	-	-	-
		1172241	-	-	-	-	-	-	-	1	-	-	-	-	-	-
KK	Trap, Drain Assembly	1171917	1	1	1	1	1	1	1	1	1	1	1	1	1	
LL	Sightglass	1012756	1	1	1	1	1	1	1	1	1	1	1	1	1	
MM	Plate, Restrictor	1175729	1	-	-	-	-	-	-	-	-	-	-	-	-	
NN	Clip, Retainer	1175788	1	1	1	1	1	1	1	1	1	1	1	1	1	
QQ	Gasket, Trap	1013701	1	1	1	1	1	1	1	1	1	1	1	1	1	
RR	Bracket, Trap	1171986	1	1	1	1	1	1	1	1	1	1	1	1	1	
SS	Gasket, Trap Bracket	1172000	1	1	1	1	1	1	1	1	-	-	-	-	-	
		1171987	-	-	-	-	-	-	-	-	1	1	1	1	1	1
TT	Tube, Drain Coll. Box $\frac{5}{8}$ " ID	1173065	1	1	1	1	1	1	1	1	-	-	-	-	-	
		1172245	-	-	-	-	-	-	-	-	1	1	1	1	1	1
UU	Tube, Drain Tee $\frac{1}{2}$ " ID	1171989	1	1	1	1	1	1	1	1	1	1	1	1	1	
VV	Tube, Relief	1172012	1	1	1	1	1	1	1	1	1	1	1	1	1	
WW	Drain Vent	1014003	1	1	1	1	1	1	1	1	1	1	1	1	1	
ZZ	Sightglass	1172768	-	-	-	-	-	-	-	-	1	1	1	1	1	
)	<b>PART NOT ILLUSTRATED</b>															
)	Door Screws	1014488	4	4	4	4	4	4	4	4	4	4	4	4	4	4
)	Door Screws Grommets	1171990	4	4	4	4	4	4	4	4	4	4	4	4	4	4
)	Clamp, Hose $\frac{3}{4}$ "	1012976	2	2	2	2	2	2	2	2	2	2	2	2	2	2
)	Clamp, Hose $\frac{5}{8}$ "	1012975	4	4	4	4	4	4	4	4	4	4	4	4	4	4
)	Grommet, Vent	1012697	1	1	1	1	1	1	1	1	1	1	1	1	1	1
)	Bushing, Strain Relief	1945287	1	1	1	1	1	1	1	1	1	1	1	1	1	1
)	Harness, Wire	1175880	1	1	-	1	1	1	1	1	1	1	1	1	1	1
)	Harness, Wire	1175727	-	-	1	-	-	-	-	-	-	-	-	-	-	-
)	Trap, Drain Tee	1171916	1	1	1	1	1	1	1	1	1	1	1	1	1	1
)	Tube, $\frac{1}{2}$ " ID Drain	1171991	1	1	1	1	1	1	1	1	1	1	1	1	1	1
)	Tube, $\frac{1}{2}$ " ID Elbow Street	1171996	1	1	1	1	1	1	1	1	1	1	1	1	1	1
)	Coupling, $\frac{1}{2}$ " Barbed	1171993	1	1	1	1	1	1	1	1	1	1	1	1	1	1

## Replacement Parts - N9MP1 & N9MP2

**Models** - N9MP1040B08C2, N9MP1050B12C2, N9MP1060B12C2, N9MP1075B12C2, N9MP1080F16C2, N9MP1100F14C2, N9MP1100J20C2 & N9MP1125J20C2 - N9MP2050B12C2, N9MP2075B12C2, N9MP2080F16C2, N9MP2100F14C2, N9MP2100J20C2 & N9MP2125J20C2 (Natural Gas)

**Replacement part supplied will be current active part. For parts not listed, consult place of purchase.**

Key No.	Description Non- Functional	Part Number	N9MP1								N9MP2					
			040B 08C	050B 12C	060B 12C	075B 12C	080F 16C	100F 14C	100J 20C	125J 20C	050B 12C	075B 12C	080F 16C	100F 14C	100J 20C	125J 20C
)	<b>PART NOT ILLUSTRATED</b>															
)	Tube, 1/2" ID Elbow	1171992	-	-	-	-	-	-	-	-	-	1	1	1	1	1
)	Tubing, 5/8" ID Drain	1171994	1	1	1	1	1	1	1	1	1	1	1	1	1	1
)	Connector, 3/4" X 1/2"	1171995	1	1	1	1	1	1	1	1	1	1	1	1	1	1
)	Plate, Cover Trap	1171999	1	1	1	1	1	1	1	1	1	1	1	1	1	1
)	Gasket, Trap Bracket	1171987	1	1	1	1	1	1	1	1	1	1	1	1	1	1
)	Elbow, 1/2" CPVC Street	1171996	1	1	1	1	1	1	1	1	1	1	1	1	1	1
)	Grommet, Casing	1171997	1	1	1	1	1	1	1	1	1	1	1	1	1	1
)	Tube, Relief Ext.	1172239	1	1	1	1	1	1	1	1	1	1	1	1	1	1
)	Connector, Relief Tube	1171998	1	1	1	1	1	1	1	1	1	1	1	1	1	1
)	Gasket, Cover Plate	1172000	1	1	1	1	1	1	1	1	1	1	1	1	1	1
)	Cap, Drain Tee	1171916	1	1	1	1	1	1	1	1	1	1	1	1	1	1
)	Clamp, Tee Cap	1172002	1	1	1	1	1	1	1	1	1	1	1	1	1	1
)	Coupling, Air Intake	1012284	-	-	-	-	-	-	-	-	-	1	1	1	1	1
)	Gasket, Air Intake	1012583	-	-	-	-	-	-	-	-	-	1	1	1	1	1
)	Gasket, Trap Bracket	1171987	-	-	-	-	-	-	-	-	-	1	1	1	1	1
)	Grommet, Vinyl (Gas Inlet)	1009535	-	-	-	-	-	-	-	-	-	1	1	1	1	1
)	Bushing, Strain Relief	1945287	-	-	-	-	-	-	-	-	-	1	1	1	1	1
)	Installation Manual	44001102401	1	1	1	1	1	1	1	1	1	1	1	1	1	1
)	User's Manual	44102201104	1	1	1	1	1	1	1	1	1	1	1	1	1	1

## Replacement Parts - N9MPD

**Models** - N9MPD040F08A2, N9MPD050F12A2, N9MPD060F12A2, N9MPD075F12A2, N9MPD080J16A2, N9MPD100J14A2, N9MPD100J20A2 & N9MPD125L20A2 (Natural Gas)

**Replacement part supplied will be current active part. For parts not listed, consult place of purchase.**

Key No.	Description Functional	Part Number	N9MPD							
			040F08A	050F12A	060F12A	075F12A	080J16A	100J14A	100J20A	125L20A
1	Heat Exchanger, Primary	1012850	1	1	-	-	-	-	-	-
		1012854	-	-	1	1	-	-	-	-
		1012858	-	-	-	-	1	1	1	-
		1012862	-	-	-	-	-	-	-	1
2	Heat Exchanger, Secondary	1013762	1	1	-	-	-	-	-	-
		1013763	-	-	1	1	-	-	-	-
		1013765	-	-	-	-	1	1	1	-
		1013767	-	-	-	-	-	-	-	1
3	Motor, Blower	1175724	1	-	-	-	-	-	-	-
		1172488	-	1	-	-	1	-	-	-
		1172487	-	-	1	1	-	1	-	-
		1172489	-	-	-	-	-	-	1	1
4	Mount, Motor kit*	1014824	1	1	-	-	-	-	-	-
		1014822	-	-	1	1	-	1	-	-
		1014823	-	-	-	-	1	-	1	1
5	Wheel, Blower	1013011	1	1	-	-	-	-	-	-
		1011420	-	-	1	1	1	1	1	1
6	Transformer	1172810	1	1	1	1	1	1	1	
7	Capacitor, 7.5Mfd.,370V 10Mfd.,370V 40Mfd.,370V	1171728	-	-	1	1	-	1	-	-
		1171729	1	1	-	-	1	-	-	-
		1171982	-	-	-	-	-	-	1	1
8	Control, Fan Timer	1172550	1	1	1	1	1	1	1	
9	Switch, Interlock	1171981	1	1	1	1	1	1	1	
10	Switch, Pressure	1175818	1	-	-	-	-	-	-	-
		1175726	-	-	1	-	-	-	-	-
		1013802	-	1	-	1	-	1	1	-
		1013812	-	-	-	-	1	-	-	-
10	Switch, (Hi Altitude)	1175819	1	-	1	-	-	-	-	-
		1013803	-	1	-	1	-	1	1	-
		1013813	-	-	-	-	1	-	-	-
		1013157	-	-	-	-	-	-	-	1
11	Blower, Exhaust	1172823	1	1	1	1	1	1	1	-
		1172824	-	-	-	-	-	-	-	-
12	Valve, Gas Nat.	1175705	1	1	1	1	1	1	1	
13	Flame Sensor	1172827	1	1	1	1	1	1	1	
14	Igniter	1172533	1	1	1	1	1	1	1	
15	Orifice, Burner #42 Nat. #44 Nat.	1011351	-	2	-	3	-	4	4	5
		1011352	2	-	3	-	4	-	-	-
16	Switch, Limit (Rollout)	1013102	2	2	2	2	2	2	2	
17	Burner Assembly	1172884	1	1	-	-	-	-	-	-
		1172965	-	-	1	1	-	-	-	-
		1172966	-	-	-	-	1	1	1	-
		1172967	-	-	-	-	-	-	-	1
18	Switch, Limit (Main)	1320366	1	1	-	-	-	-	-	-
		1320361	-	-	1	-	-	-	-	-
		34335002	-	-	-	1	-	-	-	-
		1008445	-	-	-	-	-	-	-	1
		1320367	-	-	-	-	1	1	1	-

\*See Table below for bellyband location on motor

Bellyband Location on Motor	
Model N9MPD	A(in.)
040F08A2	1.65"
050F12A2	2.09"
060F12A2	1.38"
075F12A2	1.38"

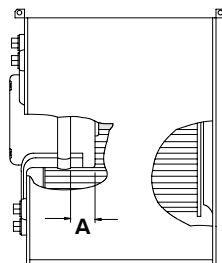

Bellyband Location on Motor	
Model N9MPD	A(in.)
080J16A2	1.81"
100J14A2	1.38"
100J20A2	1.65"
125L20A2	1.65"

## Replacement Parts - N9MPD

**Models** - N9MPD040812A2, N9MPD050F12A2, N9MPD060F12A2, N9MPD075F12A2, N9MPD080J16A2, N9MPD100J14A2, N9MPD100J20A2 & N9MPD125L20A2 (Natural Gas)

**Replacement part supplied will be current active part. For parts not listed, consult place of purchase.**

Key No.	Description Non- Functional	Part Number	N9MPD							
			040F08A	050F12A	060F12A	075F12A	080J16A	100J14A	100J20A	125L20A
A	Panel, Top	1012866	1	1	1	1	-	-	-	-
		1012867	-	-	-	-	1	1	1	-
		1012868	-	-	-	-	-	-	-	1
B	Gasket, Top Panel	1012603	1	1	1	1	-	-	-	-
		1012604	-	-	-	-	1	1	1	-
		1012605	-	-	-	-	-	-	-	1
F	Partition, Blower	1172008	1	1	-	-	-	-	-	-
		1172005	-	-	1	1	-	-	-	-
		1172006	-	-	-	-	1	1	1	-
		1172007	-	-	-	-	-	-	-	1
H	Housing, Blower	1172885	1	1	-	-	-	-	-	-
		1172969	-	-	1	1	1	1	1	1
J	Panel, Blower Cutoff	721020013	1	1	-	-	-	-	-	-
		721020008	-	-	1	1	1	1	1	1
K	Hanger, Blower	1012328	2	2	2	2	2	2	2	2
L	Door, Blower	1014847	1	1	1	1	-	-	-	-
		1014848	-	-	-	-	1	1	1	-
		1012804	-	-	-	-	-	-	-	1
M	Bracket, Door Filler	1172232	1	1	1	1	-	-	-	-
		1172233	-	-	-	-	1	1	1	-
		1172234	-	-	-	-	-	-	-	1
N	Door, Front	1012806	1	1	1	1	-	-	-	-
		1012807	-	-	-	-	1	1	1	-
		1012808	-	-	-	-	-	-	-	1
O	Clamp, Capacitor	1170643	1	1	1	1	1	1	-	-
		1014315	-	-	-	-	-	-	1	1
P	Transition Assembly	1172228	1	1	1	1	-	-	-	-
		1172229	-	-	-	-	1	1	1	-
		1172230	-	-	-	-	-	-	-	1
Q	Gasket, Blower	1014425	1	1	1	1	1	1	1	1
R	Board, Insulating	1012418	1	1	1	1	-	-	-	-
		1012419	-	-	-	-	1	1	1	-
		1012420	-	-	-	-	-	-	-	1
S	Box, Collector	1012244	1	1	1	1	-	-	-	-
		1012245	-	-	-	-	1	1	1	-
		1012246	-	-	-	-	-	-	-	1
T	Gasket, Transition	1013263	1	1	-	-	-	-	-	-
		1013080	-	-	1	1	-	-	-	-
		1013083	-	-	-	-	1	1	1	-
		1013084	-	-	-	-	-	-	-	1
U	Gasket, Collector Box	1012594	1	1	1	1	-	-	-	-
		1012595	-	-	-	-	1	1	1	-
		1012596	-	-	-	-	-	-	-	1
V	Partition, Frt Ht Exchanger	1012650	1	1	-	-	-	-	-	-
		1012648	-	-	1	1	-	-	-	-
		1012651	-	-	-	-	1	1	1	-
		1012653	-	-	-	-	-	-	-	1
W	Gasket, Attachment Plate	1012542	2	2	-	-	-	-	-	-
		1012543	-	-	2	2	-	-	-	-
		1012544	-	-	-	-	2	2	2	-
		1012545	-	-	-	-	-	-	-	2



## Replacement Parts - N9MPD

**Models** - N9MPD040F08A2, N9MPD050F12A2, N9MPD060F12A2, N9MPD075F12A2, N9MPD080J16A2, N9MPD100J14A2, N9MPD100J20A2 & N9MPD125L20A2 (Natural Gas)

**Replacement part supplied will be current active part. For parts not listed, consult place of purchase.**

Key No.	Description Non- Functional	Part Number	N9MPD							
			040F08A	050F12A	060F12A	075F12A	080J16A	100J14A	100J20A	125L20A
X	Cover, Junction Box	1012350	1	1	1	1	1	1	1	1
Y	Box, Junction	1172860	1	1	1	1	1	1	1	1
BB	Manifold	1012276	1	1	-	-	-	-	-	-
		1012277	-	-	1	1	-	-	-	-
		1012278	-	-	-	-	1	1	1	-
		1012279	-	-	-	-	-	-	-	1
CC	Bottom, Burner Box	1172847	1	1	-	-	-	-	-	-
		1172848	-	-	1	1	-	-	-	-
		1172849	-	-	-	-	1	1	1	-
		1172850	-	-	-	-	-	-	-	1
DD	Baffle, Burner Box	1012338	1	1	1	1	-	-	-	-
		1012339	-	-	-	-	1	1	1	-
		1012340	-	-	-	-	-	-	-	1
EE	Top, Burner Box	1013702	1	1	1	1	-	-	-	-
		1013703	-	-	-	-	1	1	1	-
		1013704	-	-	-	-	-	-	-	1
FF	Bracket, Manifold Support	1012377	2	2	2	2	2	2	2	2
GG	Bracket, Burner Box Side	1012532	2	2	2	2	2	2	2	2
HH	Bracket, Control Mounting	1172845	1	1	1	1	1	1	1	1
JJ	Tube, Sensor	1172240	1	1	1	1	1	1	1	-
		1172238	-	-	-	-	-	-	-	1
		1172241	-	-	-	-	-	-	-	1
KK	Trap, Drain Assembly	1171917	1	1	1	1	1	1	1	1
LL	Sightglass	1012756	1	1	1	1	1	1	1	1
MM	Plate, Restrictor	1175816	1	-	-	-	-	-	-	-
		1175815	-	-	1	-	-	-	-	-
NN	Clip, Retainer	1175788	1	1	1	1	1	1	1	1
QQ	Gasket, Trap	1013701	1	1	1	1	1	1	1	1
RR	Bracket, Trap	1171986	1	1	1	1	1	1	1	1
SS	Gasket, Trap Bracket	1171987	1	1	1	1	1	1	1	1
TT	Tube, Drain Coll. Box $\frac{5}{8}$ " ID	1172245	1	1	1	1	1	1	1	1
UU	Tube, Drain Tee $\frac{1}{2}$ " ID	1171989	1	1	1	1	1	1	1	1
VV	Tube, Relief	1172012	1	1	1	1	1	1	1	1
WW	Drain Vent	1014003	1	1	1	1	1	1	1	1
YY	Tee, Drain	1171915	1	1	1	1	1	1	1	1
ZZ	Sightglass	1172768	1	1	1	1	1	1	1	1
)	<b>PART NOT ILLUSTRATED</b>									
)	Door Screws	1014488	4	4	4	4	4	4	4	4
)	Door Screws Grommets	1171990	4	4	4	4	4	4	4	4
)	Coupling, Air Intake	1012284	1	1	1	1	1	1	1	1
)	Gasket, Air Intake	1012583	1	1	1	1	1	1	1	1
)	Clamp, Hose $\frac{3}{4}$ "	1012976	2	2	2	2	2	2	2	2
)	Clamp, Hose $\frac{5}{8}$ "	1012975	4	4	4	4	4	4	4	4
)	Coupling, Discharge	1002522	2	2	2	2	2	2	2	2
)	Clamp Hose	1013830	2	2	2	2	2	2	2	2
)	Grommet, Vent	1012697	1	1	1	1	1	1	1	1
)	Bushing, Strain Relief	1945287	1	1	1	1	1	1	1	1
)	Grommet, Vinyl (gas Inlet)	1009535	1	1	1	1	1	1	1	1
)	Harness, Wire	1175880	1	1	1	1	1	1	1	1

## Replacement Parts - N9MPD

**Models** - N9MPD040F08A2, N9MPD050F12A2, N9MPD060F12A2, N9MPD075F12A2, N9MPD080J16A2, N9MPD100J14A2, N9MPD100J20A2 & N9MPD125L20A2 (Natural Gas)

**Replacement part supplied will be current active part. For parts not listed, consult place of purchase.**

Key No.	Description Non-Functional	Part Number	N9MPD							
			040F08A	050F12A	060F12A	075F12A	080J16A	100J14A	100J20A	125L20A
) (	Trap, Drain Tee	1171916	1	1	1	1	1	1	1	1
) (	Tube, 1/2" ID Drain	1171991	1	1	1	1	1	1	1	1
) (	Tube, 1/2" ID Elbow	1171992	2	2	2	2	2	2	2	2
) (	Coupling, 1/2" Barbed	1171993	1	1	1	1	1	1	1	1
) (	Tubing, 5/8" ID Drain	1171994	1	1	1	1	1	1	1	1
) (	Connector, 3/4" X 1/2"	1171995	1	1	1	1	1	1	1	1
) (	Elbow, 1/2" CPVC Street	1171996	1	1	1	1	1	1	1	1
) (	Grommet, Casing	1171997	1	1	1	1	1	1	1	1
) (	Tube, Relief Ext.	1172239	1	1	1	1	1	1	1	1
) (	Connector, Relief Tube	1171998	1	1	1	1	1	1	1	1
) (	Plate, Cover	1171999	1	1	1	1	1	1	1	1
) (	Gasket, Cover Plate	1172000	1	1	1	1	1	1	1	1
) (	Cap, Drain Tee	1172255	1	1	1	1	1	1	1	1
) (	Clamp, Tee Cap	1172256	1	1	1	1	1	1	1	1
) (	Bottom Plug	1012977	1	1	1	1	1	1	1	1
		1013504	1	1	1	1	1	1	1	1
		1013470	1	1	1	1	1	1	1	1
) (	Installation Manual	44001102401	1	1	1	1	1	1	1	1
) (	User's Manual	44102201104	1	1	1	1	1	1	1	1

## Replacement Parts - \*9MPD

**Models** - \*9MPD050F12C2, \*9MPD075F12C2, \*9MPD080J16C2, \*9MPD100J14C2, \*9MPD100J20C2 & \*9MPD125L20C2 (Natural Gas) \*Denotes Brand

**Replacement part supplied will be current active part. For parts not listed, consult place of purchase.**

Key No.	Description Functional	Part Number	*9MPD					
			050F12C	075F12C	080J16C	100J14C	100J20C	125L20C
1	Heat Exchanger, Primary	1012850	1	-	-	-	-	-
		1012854	-	1	-	-	-	-
		1012858	-	-	1	1	1	-
		1012862	-	-	-	-	-	1
2	Heat Exchanger, Secondary	1013762	1	-	-	-	-	-
		1013763	-	1	-	-	-	-
		1013765	-	-	1	1	1	-
		1013767	-	-	-	-	-	1
3	Motor, Blower	1172488	1	-	1	-	-	-
		1172487	-	1	-	1	-	-
		1172489	-	-	-	-	1	1
4	Mount, Motor kit*	1014824	1	-	-	-	-	-
		1014822	-	1	-	1	-	-
		1014823	-	-	1	-	1	1
5	Wheel, Blower	1013011	1	-	-	-	-	-
		1011420	-	1	1	1	1	1
6	Transformer	1172810	1	1	1	1	1	1
7	Capacitor, 7.5Mfd.,370V 10Mfd.,370V 40Mfd.,370V	1171728	-	1	-	1	-	-
		1171729	1	-	1	-	-	-
		1171982	-	-	-	-	1	1
8	Control, Fan Timer	1172550	1	1	1	1	1	1
9	Switch, Interlock	1171981	1	1	1	1	1	1
10	Switch, Pressure	1013802	1	1	-	1	1	-
		1013812	-	-	1	-	-	-
		1013166	-	-	-	-	-	1
11	Blower, Exhaust	1172823	1	1	1	1	1	-
		1172824	-	-	-	-	-	1
12	Valve, Gas Nat.	1175705	1	1	1	1	1	1
13	Flame Sensor	1172827	1	1	1	1	1	1
14	Igniter	1172533	1	1	1	1	1	1
15	Orifice, Burner #42 Nat. #44 Nat.	1011351	2	3	-	4	4	5
		1011352	-	-	4	-	-	-
16	Switch, Limit (Rollout)	1013102	2	2	2	2	2	2
17	Burner Assembly	1172884	1	-	-	-	-	-
		1172965	-	1	-	-	-	-
		1172966	-	-	1	1	1	-
		1172967	-	-	-	-	-	1
18	Switch, Limit (Main)	1320366	1	-	-	-	-	-
		34335002	-	1	-	-	-	-
		1008445	-	-	-	-	-	1
		1320367	-	-	1	1	1	-

\*See Table below for bellyband location on motor

Bellyband Location on Motor	
Model *9MPD	A(in.)
050F12C2	2.09"
075F12C2	1.38"
080J16C2	1.81"
100J14C2	1.38"
100J20C2	1.65"
125L20C2	1.65"

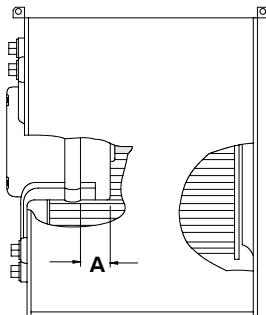

## Replacement Parts - \*9MPD

**Models** - \*9MPD050F12C2, \*9MPD075F12C2, \*9MPD080J16C2, \*9MPD100J14C2, \*9MPD100J20C2 & \*9MPD125L20C2 (Natural Gas) \*Denotes Brand

**Replacement part supplied will be current active part. For parts not listed, consult place of purchase.**

Key No.	Description Non- Functional	Part Number	*9MPD					
			050F12C	075F12C	080J16C	100J14C	100J20C	125L20C
A	Panel, Top	1012866	1	1	-	-	-	-
		1012867	-	-	1	1	1	-
		1012868	-	-	-	-	-	1
B	Gasket, Top Panel	1012603	1	1	-	-	-	-
		1012604	-	-	1	1	1	-
		1012605	-	-	-	-	-	1
F	Partition, Blower	1172008	1	-	-	-	-	-
		1172005	-	1	-	-	-	-
		1172006	-	-	1	1	1	-
		1172007	-	-	-	-	-	1
H	Housing, Blower	1172885	1	-	-	-	-	-
		1172969	-	1	1	1	1	1
J	Panel, Blower Cutoff	721020013	1	-	-	-	-	-
		721020008	-	1	1	1	1	1
K	Hanger, Blower	1012328	2	2	2	2	2	2
L	Door, Blower (Tempstar only) (Tempstar only) (Tempstar only) (Comfortmaker/Keeprite only) (Comfortmaker/Keeprite only) (Comfortmaker/Keeprite only) (Heil/Arcoaire only) (Heil/Arcoaire only) (Heil/Arcoaire only)	1173015	1	1	-	-	-	-
		1173016	-	-	1	1	1	-
		1173082	-	-	-	-	-	1
		1173009	1	1	-	-	-	-
		1173010	-	-	1	1	1	-
		1173072	-	-	-	-	-	1
		1173012	1	1	-	-	-	-
		1173013	-	-	1	1	1	-
1173075	-	-	-	-	-	1		
M	Bracket, Door Filler	1172232	1	1	-	-	-	-
		1172233	-	-	1	1	1	-
		1172234	-	-	-	-	-	1
N	Door, Front (Tstar only) (Tstar only) (Tstar only) (Cmaker/Keeprite only) (Cmaker/Keeprite only) (Cmaker/Keeprite only) (Heil/Arco only) (Heil/Arco only) (Heil/Arco only)	1013154	1	1	-	-	-	-
		1013155	-	-	1	1	1	-
		1013156	-	-	-	-	-	1
		1013148	1	1	-	-	-	-
		1013149	-	-	1	1	1	-
		1013150	-	-	-	-	-	1
		1013145	1	1	-	-	-	-
		1013146	-	-	1	1	1	-
1013147	-	-	-	-	-	1		
O	Clamp, Capacitor	1170643	1	1	1	1	-	-
		1014315	-	-	-	-	1	1
P	Transition Assembly	1172228	1	1	-	-	-	-
		1172229	-	-	1	1	1	-
		1172230	-	-	-	-	-	1
Q	Gasket, Blower	1014425	1	1	1	1	1	1
R	Board, Insulating	1012418	1	1	-	-	-	-
		1012419	-	-	1	1	1	-
		1012420	-	-	-	-	-	1
S	Box, Collector	1012244	1	1	-	-	-	-
		1012245	-	-	1	1	1	-
		1012246	-	-	-	-	-	1
T	Gasket, Transition	1013263	1	-	-	-	-	-
		1013080	-	1	-	-	-	-
		1013083	-	-	1	1	1	-
		1013084	-	-	-	-	-	1
U	Gasket, Collector Box	1012594	1	1	-	-	-	-
		1012595	-	-	1	1	1	-
		1012596	-	-	-	-	-	1
V	Partition, Frt Ht Exchanger	1012650	1	-	-	-	-	-
		1012648	-	1	-	-	-	-
		1012651	-	-	1	1	1	-
		1012653	-	-	-	-	-	1
W	Gasket, Attachment Plate	1012542	2	-	-	-	-	-
		1012543	-	2	-	-	-	-
		1012544	-	-	2	2	2	-
		1012545	-	-	-	-	-	2

## Replacement Parts - \*9MPD

**Models** - \*9MPD050F12C2, \*9MPD075F12C2, \*9MPD080J16C2, \*9MPD100J14C2, \*9MPD100J20C2 & \*9MPD125L20C2 (Natural Gas) \*Denotes Brand

**Replacement part supplied will be current active part. For parts not listed, consult place of purchase.**

Key No.	Description Non- Functional	Part Number	*9MPD					
			050F12C	075F12C	080J16C	100J14C	100J20C	125L20C
X	Cover, Junction Box	1012350	1	1	1	1	1	1
Y	Box, Junction	1172860	1	1	1	1	1	1
BB	Manifold	1012276	1	-	-	-	-	-
		1012277	-	1	-	-	-	-
		1012278	-	-	1	1	1	-
		1012279	-	-	-	-	-	1
CC	Bottom, Burner Box	1172847	1	1	-	-	-	-
		1172849	-	-	1	1	1	-
		1172850	-	-	-	-	-	1
DD	Baffle, Burner Box	1012338	1	1	-	-	-	-
		1012339	-	-	1	1	1	-
		1012340	-	-	-	-	-	1
EE	Top, Burner Box	1013702	1	1	-	-	-	-
		1013703	-	-	1	1	1	-
		1013704	-	-	-	-	-	1
FF	Bracket, Manifold Support	1012377	2	2	2	2	2	2
GG	Bracket, Burner Box Side	1012532	2	2	2	2	2	2
HH	Bracket, Control Mounting	1172845	1	1	1	1	1	1
JJ	Tube, Sensor	1172240	1	1	1	1	1	-
		1172238	-	-	-	-	-	1
		1172241	-	-	-	-	-	1
KK	Trap, Drain Assembly	1171917	1	1	1	1	1	1
LL	Sightglass Comfortmaker & Heil Tempstar Only	1013235	1	1	1	1	1	1
		1013236	1	1	1	1	1	1
NN	Clip, Retainer	1175788	1	1	1	1	1	1
QQ	Gasket, Trap	1013701	1	1	1	1	1	1
RR	Bracket, Trap	1171986	1	1	1	1	1	1
SS	Gasket, Trap Bracket	1171987	1	1	1	1	1	1
TT	Tube, Drain Coll. Box <sup>5</sup> / <sub>8</sub> " ID	1172245	1	1	1	1	1	1
UU	Tube, Drain Tee <sup>1</sup> / <sub>2</sub> " ID	1171989	1	1	1	1	1	1
VV	Tube, Relief	1172012	1	1	1	1	1	1
WW	Drain Vent	1014003	1	1	1	1	1	1
YY	Tee, Drain	1171915	1	1	1	1	1	1
ZZ	Sightglass	1172768	1	1	1	1	1	1
)	<b>PART NOT ILLUSTRATED</b>							
)	Door Screws	1014488	4	4	4	4	4	4
)	Door Screws Grommets	1171990	4	4	4	4	4	4
)	Coupling, Air Intake	1012284	1	1	1	1	1	1
)	Gasket, Air Intake	1012583	1	1	1	1	1	1
)	Clamp, Hose <sup>3</sup> / <sub>4</sub> "	1012976	2	2	2	2	2	2
)	Clamp, Hose <sup>5</sup> / <sub>8</sub> "	1012975	4	4	4	4	4	4
)	Coupling, Discharge	1002522	2	2	2	2	2	2
)	Clamp Hose	1013830	2	2	2	2	2	2
)	Grommet, Vent	1012697	1	1	1	1	1	1
)	Bushing, Strain Relief	1945287	1	1	1	1	1	1
)	Grommet, Vinyl (gas Inlet)	1009535	1	1	1	1	1	1
)	Harness, Wire	1175880	1	1	1	1	1	1

## Replacement Parts - \*9MPD

**Models** - \*9MPD050F12C2, \*9MPD075F12C2, \*9MPD080J16C2, \*9MPD100J14C2, \*9MPD100J20C2 & \*9MPD125L20C2 (Natural Gas) \*Denotes Brand

**Replacement part supplied will be current active part. For parts not listed, consult place of purchase.**

Key No.	Description Non-Functional	Part Number	*9MPD					
			050F12C	075F12C	080J16C	100J14C	100J20C	125L20C
) (	Trap, Drain Tee	1171916	1	1	1	1	1	1
) (	Tube, 1/2" ID Drain	1171991	1	1	1	1	1	1
) (	Tube, 1/2" ID Elbow	1171992	2	2	2	2	2	2
) (	Coupling, 1/2" Barbed	1171993	1	1	1	1	1	1
) (	Tubing, 5/8" ID Drain	1171994	1	1	1	1	1	1
) (	Connector, 3/4" X 1/2"	1171995	1	1	1	1	1	1
) (	Elbow, 1/2" CPVC Street	1171996	1	1	1	1	1	1
) (	Grommet, Casing	1171997	1	1	1	1	1	1
) (	Tube, Relief Ext.	1172239	1	1	1	1	1	1
) (	Connector, Relief Tube	1171998	1	1	1	1	1	1
) (	Plate, Cover	1171999	1	1	1	1	1	1
) (	Gasket, Cover Plate	1172000	1	1	1	1	1	1
) (	Cap, Drain Tee	1172255	1	1	1	1	1	1
) (	Clamp, Tee Cap	1172256	1	1	1	1	1	1
) (	Installation Manual	44001102401	1	1	1	1	1	1
) (	User's Manual	44102201104	1	1	1	1	1	1