



**N4A5**

**Performance Series  
Product Specifications**

**EFFICIENT 14 SEER/11.7–12.2 EER AIR CONDITIONER  
ENVIRONMENTALLY SOUND R-410A REFRIGERANT**

**1-1/2 THRU 5 TONS SPLIT SYSTEM**

**208/230 Volt, 1-phase, 60 Hz**

**208/230, 460 & 575 Volt, 3-phase, 60 Hz**

**REFRIGERATION CIRCUIT**

- Scroll compressors on all models
- Filter-Drier supplied with every unit for field installation
- Copper tube / aluminum fin coil

**EASY TO INSTALL AND SERVICE**

- Easy Access service valves on all models
- External high and low refrigerant service ports
- Only two screws to access control panel
- Factory charged with R-410A refrigerant

**BUILT TO LAST**

- Baked-on powder coat finish over galvanized steel
- Post-painted (black) coil fins
- Coated, weather-resistant cabinet screws
- Coated inlet grille with 3/8" (10mm) grille spacing for extra protection (hail guard)

**LIMITED WARRANTY\***

- 10 year parts limited warranty (including compressor and coil) with timely registration
- 5 year parts limited warranty if not registered within 90 days of original installation
- \* See warranty certificate for complete details and restrictions



Use of the AHRI Certified TM Mark indicates a manufacturer's participation in the program. For verification of certification for individual products, go to [www.ahridirectory.org](http://www.ahridirectory.org).



Model Number	Size (tons)	Nominal BTU/hr	SEER	EER	Max. Fuse or Breaker	Operating Dimensions depth x height x width in. (mm)	Ship / Operating Weight lbs.(kg)
N4A518GKC	1-1/2	18,000	14.00	12.20	20	25-3/4 x 25 x 25 (654 x 635 x 635)	145/122 (66/55)
N4A524GKC	2	24,000	14.50	12.50	20	25-3/4 x 32-5/16 x 32-5/16 (654 x 821 x 821)	148/123 (67/56)
N4A530GKC	2-1/2	30,000	14.50	12.50	25	31-3/16 x 31-13/16 x 31-13/16 (792 x 808 x 808)	186/151 (84/69)
N4A536GKC	3	36,000	14.00	12.20	30	31-3/16 x 31-3/16 x 35-3/16 (792 x 894 x 894)	171/151(78/69)
N4A542GKC	3-1/2	42,000	14.00	12.20	35	31-3/16 x 28-7/16 x 28-7/16 (792 x 722 x 722)	226/191 (103/87)
N4A548GKC	4	48,000	14.50	11.70	35	31-3/16 x 28-7/16 x 28-7/16 (792 x 722 x 722)	200/182 (91/83)
N4A560GKC	5	60,000	14.00	11.70	40	31-3/16 x 31-13/16 x 31-13/16 (792 x 808 x 808)	218/197 (99/89)

<b>OUTDOOR UNIT MODEL NUMBER IDENTIFICATION GUIDE</b>											
Digit Position:	1	2	3	4	5, 6	7	8	9	10	11	12
Example Part Number:	<b>N</b>	<b>4</b>	<b>A</b>	<b>5</b>	<b>18</b>	<b>G</b>	<b>K</b>	<b>C</b>	<b>1</b>	<b>0</b>	<b>0</b>
H = Airquest Mainline											
N = Airquest Entry <b>BRANDING</b>											
4 = R-410A <b>REFRIGERANT</b>											
A = Air Conditioner											
H = Heat Pump <b>TYPE</b>											
5 = 15 SEER <b>NOMINAL EFFICIENCY</b>											
18 = 18,000 BTUH = 1-1/2 tons											
24 = 24,000 BTUH = 2 tons											
30 = 30,000 BTUH = 2-1/2 tons											
36 = 36,000 BTUH = 3 tons											
42 = 42,000 BTUH = 3-1/2 tons											
48 = 48,000 BTUH = 4 tons											
60 = 60,000 BTUH = 5 tons <b>NOMINAL CAPACITY</b>											
A = Standard Grille											
G = Coil Guard Grille											
C = Coastal <b>FEATURES</b>											
K = 208/230-1-60											
H = 208/230-3-60											
L = 460-3-60											
S = 575-3-60 <b>VOLTAGE</b>											
Sales Code											
Engineering Revision											
Extra Digit											
Extra Digit											

<b>ACCESSORIES PART NUMBER IDENTIFICATION GUIDE</b>									
Digit Position:	1	2	3	4	5	6, 7	8, 9	10, 11	
Example Part Number:	<b>N</b>	<b>A</b>	<b>S</b>	<b>A</b>	<b>0</b>	<b>01</b>	<b>01</b>	<b>CH</b>	
N = Non-Branded <b>BRANDING</b>									
A = Accessory <b>PRODUCT GROUP</b>									
S = Split System (AC & HP) <b>KIT USAGE</b>									
A = Original									
B = 2nd Generation <b>MAJOR SERIES</b>									
0 = Generic or Not Applicable									
2 = R-22									
4 = R-410A <b>REFRIGERANT</b>									
Product Identifier Number									
Package Quantity									
Type of Kit (Example: CH = Crankcase Heater)									

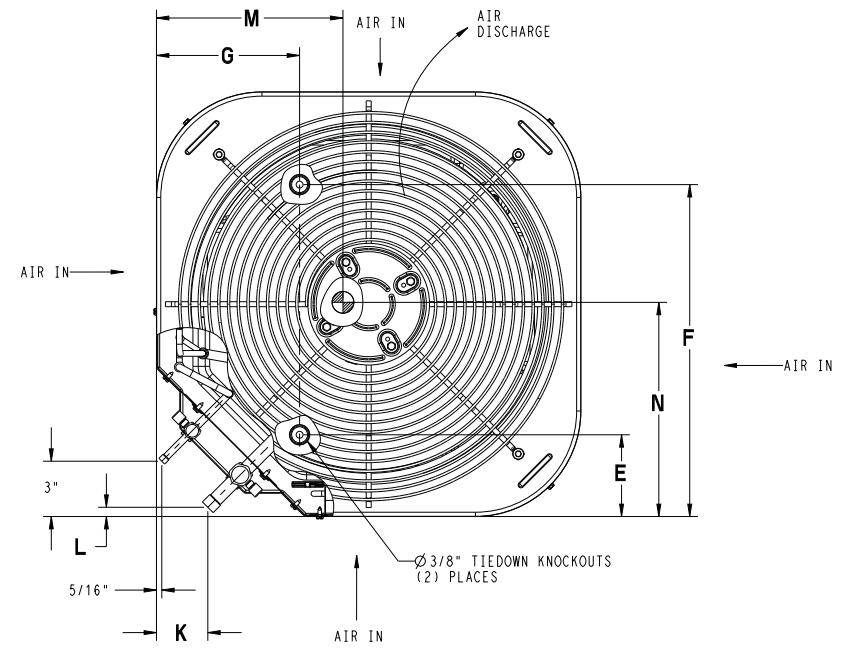
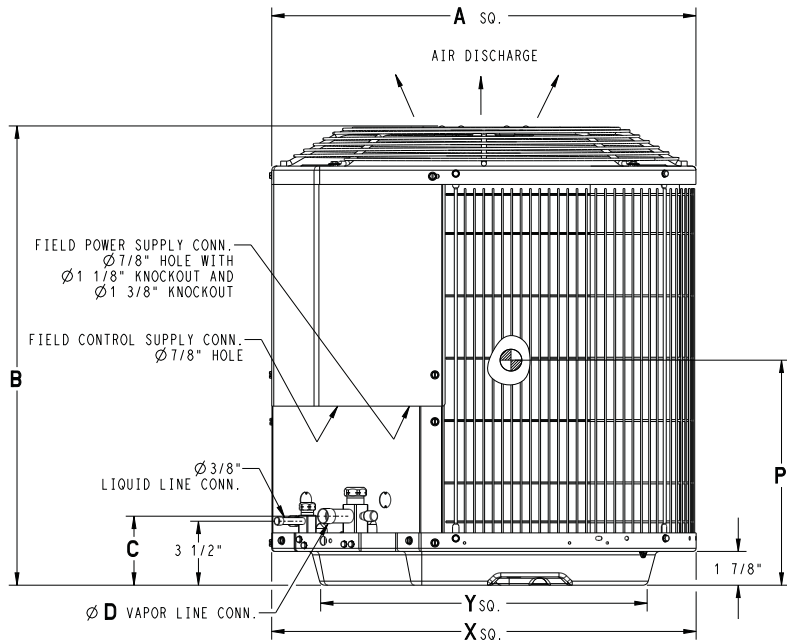

SD5270-4 REV B

1. Allow 24" clearance to service side of unit, 48" above unit, 6" on one side, 12" on remaining sides.
2. Maintain a distance of 24" between units or 18" if no overhang within 12".
3. Minimum outdoor operating ambient in cooling mode is 55°F, max 125°F.
4. Center of Gravity

Model	Dimensions Inches (English)												Minimum Ground Mounting Pad Size X	Minimum Rooftop Mounting Pad Size Y	Shipping Dimensions L x W x H
	A	B	C	D	E	F	G	K	L	M	N	P			
N4A518GKC	25-3/4	25	3-3/4	3/4	4-7/16	21-1/4	9-1/8	2-13/16	1/2	13	15-1/4	9-3/4	25-3/4 x 25-3/4	20-7/16 x 20-7/16	27-7/8 x 27-7/8 x 32-9/16
N4A524GKC	25-3/4	32-5/16	3-3/4	3/4	4-7/16	21-1/4	9-1/8	2-13/16	1/2	13-5/8	13-1/4	15-1/16	25-3/4 x 25-3/4	20-7/16 x 20-7/16	27-7/8 x 27-7/8 x 36-5/8
N4A530GKC	31-3/16	31-13/16	3-3/4	3/4	6-9/16	24-11/16	9-1/8	2-13/16	1/2	16-1/8	15-1/16	12-5/8	31-3/16 x 31-3/16	23 x 23	33-3/8 x 33-3/8 x 34
N4A536GKC	31-3/16	35-3/16	3-7/8	7/8	6-9/16	24-11/16	9-1/8	2-15/16	5/8	16-1/8	16-3/8	14-7/16	31-3/16 x 31-3/16	23 x 23	33-3/8 x 33-3/8 x 37-7/16
N4A542GKC	31-3/16	28-7/16	3-7/8	7/8	6-9/16	24-11/16	9-1/8	2-15/16	5/8	15-7/8	17	11-7/8	31-3/16 x 31-3/16	23 x 23	33-3/8 x 33-3/8 x 30-5/8
N4A548GKC	31-3/16	28-7/16	3-7/8	7/8	6-9/16	24-11/16	9-1/8	2-15/16	5/8	16-3/16	16-1/4	10-1/4	31-3/16 x 31-3/16	23 x 23	33-3/8 x 33-3/8 x 30-5/8
N4A560GKC	31-3/16	31-13/16	3-7/8	7/8	6-9/16	24-11/16	9-1/8	2-15/16	5/8	15-1/2	16	10-7/8	31-3/16 x 31-3/16	23 x 23	33-3/8 x 33-3/8 x 34

4

Specifications subject to change without notice.

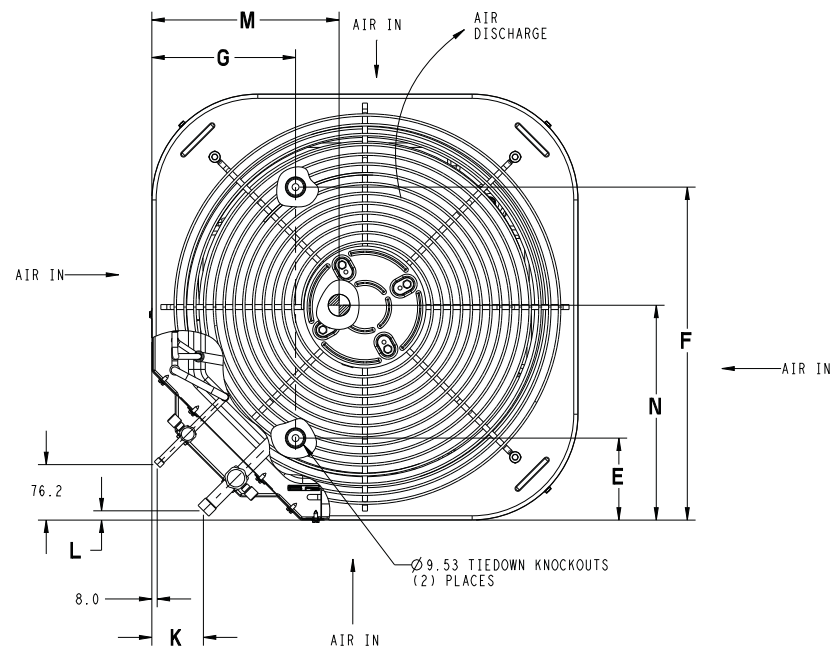
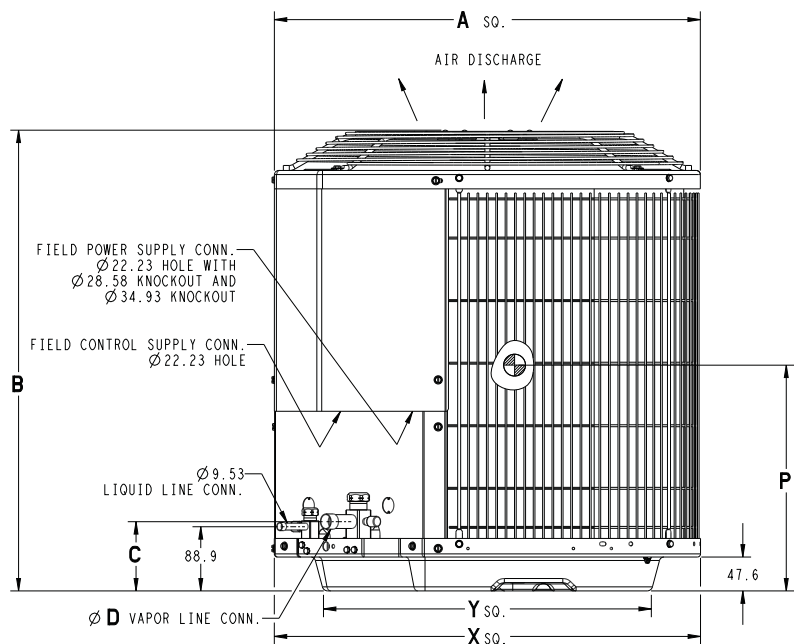

SD5270-4 REV B

1. Allow 610 mm clearance to service side of unit, 1219 mm above unit, 152 mm on one side, 305 mm on remaining sides
2. Maintain a distance of 610mm between units or 457mm if no overhang within 3.7m.
3. Minimum outdoor operating ambient in cooling mode is 13°C, max 52°C.
4. Center of Gravity

Model	Dimensions mm (SI Metric)												Minimum Ground Mounting Pad Size X	Minimum Rooftop Mounting Pad Size Y	Shipping Dimensions L x W x H
	A	B	C	D	E	F	G	K	L	M	N	P			
N4A518GKC	654	634	95	19	113	540	232	71	13	330	387	248	654 X 654	518 x 518	708 x 708 x 827
N4A524GKC	654	821	95	19	113	540	232	71	13	346	337	383	654 x 654	518 x 518	708 x 708 x 827
N4A530GKC	792	808	95	19	167	627	232	71	13	410	383	321	792 x 792	583 x 583	847 x 847 x 864
N4A536GKC	792	894	98	22	167	627	232	75	16	395	416	367	792 x 792	583 x 583	847 x 847 x 951
N4A542GKC	792	722	98	22	167	627	232	75	16	410	432	302	792 x 792	583 x 583	847 x 847 x 778
N4A548GKC	792	722	98	22	167	627	232	75	16	411	413	260	792 x 792	583 x 583	847 x 847 x 778
N4A560GKC	792	808	98	22	167	627	232	75	16	394	406	276	792 x 792	583 x 583	847 x 847 x 864

421 51 6250 00

PHYSICAL DATA (1-phase)

UNIT SIZE	18	24	30	36	42	48	60
Compressor Type	Scroll						
REFRIGERANT	R-410A						
Control	TXV Hard Shutoff						
Charge (lb)	3.20 (1.45)	4.60 (2.09)	5.67 (2.57)	6.40 (2.90)	7.46 (3.38)	8.31 (3.77)	9.39 (4.26)
COND FAN	Propeller Type, Direct Drive						
Air Discharge	Vertical						
Air Qty (CFM)	1700	1881	2614	3365	3700	3545	3700
Motor HP	1/12	1/12	1/10	1/5	1/4	1/4	1/4
Motor RPM	1100	1100	1100	1100	1100	1110	1100
COND COIL							
Face Area (Sq ft)	9.85	11.2	17.24	19.4	15.1	15.1	17.25
Fins per In.	25	25	25	25	20	20	25
Rows	1	1	1	1	2	2	2
Circuits	3	5	4	5	6	6	8
VALVE CONNECT. (In. ID)							
Vapor	3/4	3/4	3/4	7/8	7/8	7/8	7/8
Liquid	3/8						
REFRIGERANT TUBES (In. OD)							
Rated Vapor*	3/4	3/4	3/4	7/8	7/8	7/8	1-1/8
Max Liquid Line	3/8						

\* Units are rated with 25 ft (7.6 m) of lineset length. See Vapor Line Sizing and Cooling Capacity Loss table when using other sizes and lengths of lineset. **Note:** See unit Installation Instruction for proper installation.

† See Liquid Line Sizing For Cooling Only Systems with R410-A Refrigerant tables.

UNIT SIZE	V/PH	OPER VOLTS*		COMPR		FAN	MCA	MAX FUSE† or CKT BRK AMPS
		MAX	MIN	LRA	RLA	FLA		
18	208/230/1-60	253	197	47.5	9.0	0.40	11.7	20
24				62.9	10.9	0.50	14.1	20
30				67.8	12.8	0.75	16.8	25
36				79.0	13.6	1.10	18.1	30
42				109.0	16.7	1.40	22.3	35
48				105.7	15.6	1.40	20.9	35
60				127.1	20.8	1.52	27.5	40

\* Permissible limits of the voltage range at which the unit will operate satisfactorily

† Time-Delay fuse.

- FLA - Full Load Amps
- LRA - Locked Rotor Amps
- MCA - Minimum Circuit Amps
- RLA - Rated Load Amps

**NOTE:** Control circuit is 24V on all units and requires external power source. Copper wire must be used from service disconnect to unit. All motors/compressors contain internal overload protection.

Complies with 2010 requirements of ASHRAE Standards 90.1

A-WEIGHTED SOUND POWER (dBA)

UNIT SIZE	Standard Rating (dBA)	TYPICAL OCTAVE BAND SPECTRUM (dBA without tone adjustment)						
		125	250	500	1000	2000	4000	8000
18	75	46.0	55.0	59.5	64.0	60.5	54.5	48.5
24	71	50.5	53.5	58.5	60.5	60.0	56.5	52.5
30	73	49.5	56.0	62.5	64.0	60.5	57.5	53.5
36	75	49.0	57.0	62.5	66.0	61.0	58.5	52.0
42	75	52.5	63.0	64.0	63.0	62.0	58.0	52.0
48	76	53.0	61.0	64.0	65.5	62.0	59.5	50.5
60	75	53.5	57.0	62.5	63.5	61.5	57.5	51.0

**NOTE:** Tested in compliance with AHRI 270-1995 (not listed with AHRI)

A-WEIGHTED SOUND POWER (dBA) WITH SOUND SHIELD

UNIT SIZE - SE-RIES	Standard Rating (dBA)	TYPICAL OCTAVE BAND SPECTRUM (dBA without tone adjustment)						
		125	250	500	1000	2000	4000	8000
18	75	46.5	55.5	59.5	63.5	60.0	54.0	47.0
24	71	47.5	53.5	58.0	59.5	60.0	55.5	49.0
30	72	49.0	56.5	61.5	62.5	60.0	57.0	52.0
36	73	49.5	57.0	62.0	64.0	60.0	58.0	51.0
42	74	53.5	64.0	64.0	62.5	61.0	56.5	50.5
48	73	54.5	61.0	63.5	62.5	60.0	56.5	47.5
60	73	53.5	59.0	63.0	62.5	59.5	56.0	48.0

**NOTE:** Tested in compliance with AHRI 270-1995 (not listed with AHRI)

### METERING DEVICE

UNIT SIZE – SERIES	INDOOR	REQUIRED SUBCOOLING °F (°C)
18	TXV*	13 (7.22)
24		10 (5.56)
30		12 (6.67)
36		11 (6.11)
42		11 (6.11)
48		11 (6.11)
60		13 (7.22)

\* TXV must be ordered separately when indoor coil is not equipped with a TXV. TXV must be hard-shutoff type.

### VAPOR LINE SIZING AND COOLING CAPACITY LOSS

Acceptable vapor line diameters provide adequate oil return to the compressor while avoiding excessive capacity loss. The suction line diameters shown in the chart below are acceptable for AC systems with R-410A refrigerant:

Unit Nominal Size (Btuh)	Maximum Liquid Line Diameters (In. OD)	Vapor Line Diameters (In. OD)	Cooling Capacity Loss (%) Total Equivalent Line Length ft. (m)								
			26–50 (7.9–15.2)	51–80 (15.5–24.4)	81–100 (24.7–30.5)	101–125 (30.8–38.1)	126–150 (38.4–45.7)	151–175 (46.0–53.3)	176–200 (53.6–61.0)	201–225 (61.3–68.6)	226–250 (68.9–76.2)
18 1 Stage AC with R-410A	3/8	1/2	1	2	3	5	6	7	8	9	11
		5/8	0	1	1	1	2	2	2	3	3
		3/4	0	0	0	0	1	1	1	1	1
24 1 Stage AC with R-410A	3/8	5/8	0	1	2	2	3	3	4	5	5
		3/4	0	0	1	1	1	1	1	2	2
		7/8	0	0	0	0	0	1	1	1	1
30 1 Stage AC with R-410A	3/8	5/8	1	2	3	3	4	5	6	7	8
		3/4	0	0	1	1	1	2	2	2	3
		7/8	0	0	0	0	1	1	1	1	1
36 1 Stage AC with R-410A	3/8	5/8	1	2	4	5	6	8	9	10	12
		3/4	0	1	1	2	2	3	3	4	4
		7/8	0	0	0	1	1	1	1	2	2
42 1 Stage AC with R-410A	3/8	3/4	0	1	2	2	3	4	4	5	6
		7/8	0	0	1	1	1	2	2	2	3
		1 1/8	0	0	0	0	0	0	0	0	0
48 1 Stage AC with R-410A	3/8	3/4	0	1	2	3	4	5	5	6	7
		7/8	0	0	1	1	2	2	2	3	3
		1 1/8	0	0	0	0	0	0	0	1	1
60 1 Stage AC with R-410A	3/8	3/4	1	2	4	5	6	7	9	10	11
		7/8	0	1	2	2	3	4	4	5	5
		1 1/8	0	0	0	1	1	1	1	1	1

Applications in this area may be long line and may have height restrictions. See the Residential Piping and Long Line Guideline.

### TESTED AHRI COMBINATION RATINGS

NOTE: For complete ratings information, use the AHRI website directory search: [www.AHRIdirectory.org](http://www.AHRIdirectory.org).

New ratings may be listed online before Specification Sheets are updated.

UNIT SIZE	INDOOR MODEL	AHRI STANDARD RATINGS						FURNACE MODEL
		COOLING						
		CAPACITY	FACTORY ENHANCE	SEER			EER	
STANDARD	TDR			TXV				
018	EA**1917AL*	17,200	TXV		14.00		12.20	
024	EA**2517AL*	24,000	TXV		14.50		12.50	
030	EA**3721AL*	29,600	TXV		14.50		12.50	
036	EA**3721AL*	34,600	TXV		14.00		12.20	
042	EA**4321AL*	40,000	TXV		14.00		12.20	
048	EA**6124AL*	45,000	TXV		14.50		11.70	
060	EA**6024AL*	56,500	TXV		14.00		11.70	

AHRI — Air Conditioning, Heating & Refrigeration Institute

EER — Energy Efficiency Ratio — 80°F (26.6°C) indoor db/67°F (19.4°C) indoor wb & 95°F (35°C) outdoor wb.

SEER — Seasonal Energy Efficiency Ratio

TDR — Time-Delay Relay. In most cases, only one method should be used to achieve TDR function. Using more than one method in a system may cause degradation in performance.

Use either the accessory Time-Delay Relay or a furnace equipped with TDR. Most ICP furnaces are equipped with TDR.

NOTES:

1. Ratings are net values reflecting the effects of circulating fan motor heat. Supplemental electric heat is not included.
2. Tested outdoor/indoor combinations have been tested in accordance with DOE test procedures for central air conditioners. Ratings for other combinations are determined under DOE computer simulation procedures.
3. Determine actual CFM values obtainable for your system by referring to fan performance data in fan coil or furnace coil literature.
4. Do not apply with capillary tube coils as performance and reliability are significantly affected.

### TESTED AHRI COMBINATION RATINGS\*

NOTE: Ratings contained in this document are subject to change at any time.

For AHRI ratings certificates, please refer to the AHRI directory. [www.ahridirectory.org](http://www.ahridirectory.org)

Additional ratings and system combinations can be accessed via the Airquest database:

<http://www.icpeqp.com/AHRIRatings/ratings.aspx?Brand=Airquest>

Or scan this QR code:



# DETAILED COOLING CAPACITIES#

EVAPORATOR AIR		CONDENSER ENTERING AIR TEMPERATURES °F (°C)																	
CFM	EWB °F (°C)	75 (23.9)			85 (29.4)			95 (35)			105 (40.6)			115 (46.1)			125 (51.7)		
		Capacity MBtuh		Total System KW**	Capacity MBtuh		Total System KW**	Capacity MBtuh		Total System KW**	Capacity MBtuh		Total System KW**	Capacity MBtuh		Total System KW**	Capacity MBtuh		Total System KW**
		Total	Sens†		Total	Sens†		Total	Sens†		Total	Sens†		Total	Sens†		Total	Sens†	
<b>N4A518GKA Outdoor Section With EA*4X24B** Indoor Section</b>																			
525	72 (22.2)	20.56	10.96	1.11	19.77	10.67	1.25	18.93	10.35	1.40	17.98	10.00	1.58	16.91	9.62	1.77	15.70	9.18	2.00
	67 (19.4)	18.80	13.55	1.12	18.03	13.23	1.26	17.20	12.89	1.41	16.29	12.52	1.58	15.26	12.11	1.78	14.11	11.66	2.00
	63 (17.2)††	17.52	13.07	1.13	16.75	12.73	1.27	15.94	12.37	1.42	15.04	11.98	1.59	14.05	11.55	1.78	12.94	11.08	2.01
	62 (16.7)	17.21	16.10	1.13	16.46	15.76	1.27	15.67	15.40	1.42	14.89	14.89	1.59	14.11	14.11	1.78	13.23	13.23	2.00
	57 (13.9)	16.82	16.82	1.14	16.21	16.21	1.27	15.57	15.57	1.42	14.86	14.86	1.59	14.08	14.08	1.78	13.20	13.20	2.00
600	72 (22.2)	20.91	11.56	1.14	20.10	11.27	1.27	19.23	10.95	1.43	18.25	10.60	1.60	17.16	10.22	1.80	15.91	9.78	2.02
	67 (19.4)	19.14	14.52	1.15	18.35	14.21	1.28	17.50	13.87	1.44	16.56	13.49	1.61	15.51	13.08	1.80	14.33	12.62	2.03
	63 (17.2)††	17.86	13.98	1.16	17.08	13.64	1.29	16.24	13.28	1.44	15.32	12.88	1.61	14.30	12.45	1.81	13.16	11.97	2.03
	62 (16.7)	17.61	17.44	1.16	16.94	16.94	1.29	16.27	16.27	1.44	15.53	15.53	1.61	14.70	14.70	1.81	13.77	13.77	2.03
	57 (13.9)	17.54	17.54	1.16	16.91	16.91	1.29	16.24	16.24	1.44	15.50	15.50	1.61	14.68	14.68	1.81	13.75	13.75	2.03
675	72 (22.2)	21.16	12.15	1.16	20.33	11.86	1.30	19.44	11.54	1.46	18.44	11.19	1.63	17.32	10.80	1.83	16.05	10.37	2.05
	67 (19.4)	19.39	15.48	1.17	18.58	15.16	1.31	17.72	14.81	1.46	16.77	14.44	1.63	15.69	14.03	1.83	14.49	13.56	2.05
	63 (17.2)††	18.12	14.87	1.18	17.31	14.52	1.32	16.46	14.16	1.47	15.53	13.77	1.64	14.49	13.33	1.84	13.33	12.84	2.06
	62 (16.7)	18.17	18.17	1.18	17.52	17.52	1.32	16.82	16.82	1.47	16.05	16.05	1.64	15.19	15.19	1.83	14.22	14.22	2.06
	57 (13.9)	18.14	18.14	1.18	17.49	17.49	1.32	16.79	16.79	1.47	16.03	16.03	1.64	15.17	15.17	1.83	14.20	14.20	2.06

EVAPORATOR AIR		CONDENSER ENTERING AIR TEMPERATURES °F (°C)																	
CFM	EWB °F (°C)	75 (23.9)			85 (29.4)			95 (35)			105 (40.6)			115 (46.1)			125 (51.7)		
		Capacity MBtuh		Total System KW**	Capacity MBtuh		Total System KW**	Capacity MBtuh		Total System KW**	Capacity MBtuh		Total System KW**	Capacity MBtuh		Total System KW**	Capacity MBtuh		Total System KW**
		Total	Sens†		Total	Sens†		Total	Sens†		Total	Sens†		Total	Sens†		Total	Sens†	
<b>N4A524GKA Outdoor Section With EA*4X25L17** Indoor Section</b>																			
700	72 (22.2)	28.74	15.34	1.56	27.56	14.90	1.73	26.33	14.44	1.92	25.00	13.95	2.14	23.56	13.43	2.40	21.93	12.85	2.70
	67 (19.4)	26.25	18.97	1.56	25.16	18.51	1.73	24.00	18.04	1.92	22.78	17.53	2.14	21.42	16.99	2.40	19.90	16.39	2.70
	63 (17.2)††	24.47	18.29	1.56	23.43	17.84	1.73	22.35	17.34	1.92	21.19	16.83	2.14	19.88	16.27	2.40	18.47	15.67	2.71
	62 (16.7)	23.96	22.48	1.56	22.96	22.01	1.73	21.90	21.51	1.92	20.82	20.82	2.14	19.79	19.79	2.40	18.66	18.66	2.70
	57 (13.9)	23.35	23.35	1.56	22.55	22.55	1.73	21.70	21.70	1.92	20.79	20.79	2.14	19.76	19.76	2.40	18.63	18.63	2.70
800	72 (22.2)	29.22	16.18	1.60	28.00	15.74	1.77	26.71	15.27	1.96	25.33	14.78	2.18	23.85	14.26	2.44	22.16	13.67	2.73
	67 (19.4)	26.70	20.31	1.60	25.57	19.85	1.77	24.37	19.37	1.96	23.09	18.86	2.18	21.71	18.31	2.44	20.15	17.70	2.74
	63 (17.2)††	24.93	19.55	1.60	23.86	19.08	1.77	22.73	18.59	1.96	21.52	18.07	2.18	20.17	17.49	2.44	18.72	16.88	2.74
	62 (16.7)	24.49	24.27	1.60	23.54	23.54	1.77	22.63	22.63	1.96	21.65	21.65	2.18	20.56	20.56	2.44	19.34	19.34	2.74
	57 (13.9)	24.36	24.36	1.60	23.50	23.50	1.77	22.60	22.60	1.96	21.62	21.62	2.18	20.53	20.53	2.44	19.32	19.32	2.74
900	72 (22.2)	29.57	17.01	1.63	28.30	16.56	1.80	26.98	16.09	2.00	25.56	15.60	2.22	24.03	15.06	2.47	22.31	14.47	2.77
	67 (19.4)	27.04	21.62	1.63	25.87	21.16	1.80	24.63	20.66	1.99	23.32	20.15	2.22	21.91	19.59	2.47	20.32	18.96	2.77
	63 (17.2)††	25.27	20.77	1.63	24.17	20.29	1.80	23.00	19.80	2.00	21.76	19.27	2.22	20.38	18.68	2.48	18.89	18.04	2.78
	62 (16.7)	25.23	25.23	1.63	24.32	24.32	1.80	23.36	23.36	2.00	22.32	22.32	2.22	21.19	21.19	2.47	19.90	19.90	2.77
	57 (13.9)	25.19	25.19	1.63	24.28	24.28	1.80	23.33	23.33	2.00	22.30	22.30	2.22	21.16	21.16	2.47	19.87	19.87	2.77

See notes on page 6

# DETAILED COOLING CAPACITIES# CONTINUED

8

EVAPORATOR AIR		CONDENSER ENTERING AIR TEMPERATURES °F (°C)																	
		75 (23.9)			85 (29.4)			95 (35)			105 (40.6)			115 (46.1)			125 (51.7)		
		Capacity MBtuh		Total System KW**	Capacity MBtuh		Total System KW**	Capacity MBtuh		Total System KW**	Capacity MBtuh		Total System KW**	Capacity MBtuh		Total System KW**	Capacity MBtuh		Total System KW**
Total	Sens†	Total	Sens†		Total	Sens†		Total	Sens†		Total	Sens†		Total	Sens†		Total	Sens†	
<b>N4A530GKA Outdoor Section With EA*4X37L21** Indoor Section</b>																			
875	72 (22.2)	34.17	17.94	1.96	32.63	17.38	2.16	31.02	16.79	2.40	29.33	16.18	2.66	27.51	15.54	2.98	25.57	14.86	3.35
	67 (19.4)	31.02	22.10	1.97	29.61	21.53	2.17	28.14	20.94	2.40	26.58	20.31	2.66	24.91	19.66	2.98	23.13	18.96	3.35
	63 (17.2)††	28.77	21.25	1.97	27.46	20.67	2.17	26.08	20.08	2.40	24.62	19.45	2.67	23.07	18.79	2.98	21.39	18.09	3.35
	62 (16.7)	28.19	26.15	1.97	26.92	25.56	2.17	25.60	25.36	2.40	24.34	24.34	2.66	23.11	23.11	2.98	21.76	21.76	3.35
	57 (13.9)	27.51	27.51	1.97	26.51	26.51	2.17	25.45	25.45	2.40	24.30	24.30	2.66	23.07	23.07	2.98	21.73	21.73	3.35
1000	72 (22.2)	34.79	18.95	2.01	33.19	18.37	2.21	31.51	17.78	2.44	29.73	17.16	2.71	27.85	16.51	3.03	25.85	15.82	3.40
	67 (19.4)	31.61	23.69	2.01	30.13	23.11	2.21	28.60	22.50	2.44	26.98	21.87	2.71	25.25	21.19	3.03	23.42	20.49	3.40
	63 (17.2)††	29.34	22.73	2.02	27.97	22.14	2.22	26.53	21.53	2.45	25.01	20.89	2.71	23.40	20.21	3.03	21.68	19.49	3.40
	62 (16.7)	28.87	28.71	2.01	27.71	27.71	2.22	26.56	26.56	2.45	25.33	25.33	2.71	24.00	24.00	3.03	22.57	22.57	3.40
	57 (13.9)	28.75	28.75	2.01	27.66	27.66	2.22	26.52	26.52	2.45	25.29	25.29	2.71	23.97	23.97	3.03	22.54	22.54	3.40
1125	72 (22.2)	35.24	19.93	2.06	33.57	19.35	2.26	31.84	18.74	2.49	30.02	18.11	2.76	28.08	17.45	3.08	26.02	16.75	3.45
	67 (19.4)	32.05	25.24	2.06	30.53	24.64	2.26	28.94	24.02	2.49	27.27	23.37	2.76	25.51	22.69	3.08	23.63	21.95	3.45
	63 (17.2)††	29.77	24.16	2.06	28.34	23.56	2.26	26.86	22.94	2.49	25.30	22.28	2.76	23.65	21.59	3.08	21.90	20.83	3.45
	62 (16.7)	29.83	29.83	2.06	28.67	28.67	2.26	27.45	27.45	2.49	26.15	26.15	2.76	24.74	24.74	3.07	23.23	23.23	3.45
	57 (13.9)	29.79	29.79	2.06	28.63	28.63	2.26	27.41	27.41	2.49	26.11	26.11	2.76	24.71	24.71	3.07	23.20	23.20	3.45

EVAPORATOR AIR		CONDENSER ENTERING AIR TEMPERATURES °F (°C)																	
		75 (23.9)			85 (29.4)			95 (35)			105 (40.6)			115 (46.1)			125 (51.7)		
		Capacity MBtuh		Total System KW**	Capacity MBtuh		Total System KW**	Capacity MBtuh		Total System KW**	Capacity MBtuh		Total System KW**	Capacity MBtuh		Total System KW**	Capacity MBtuh		Total System KW**
Total	Sens†	Total	Sens†		Total	Sens†		Total	Sens†		Total	Sens†		Total	Sens†		Total	Sens†	
<b>N4A536GKA Outdoor Section With EA*4X37L21** Indoor Section</b>																			
1050	72 (22.2)	41.37	21.28	2.29	39.61	20.66	2.57	37.34	19.87	2.85	34.80	19.01	3.15	32.22	18.13	3.51	29.74	17.32	3.96
	67 (19.4)	38.24	26.63	2.29	36.68	26.02	2.57	34.60	25.21	2.84	32.26	24.32	3.13	29.89	23.42	3.49	27.60	22.56	3.93
	63 (17.2)††	35.82	25.73	2.30	34.41	25.13	2.57	32.47	24.32	2.84	30.30	23.42	3.12	28.06	22.51	3.48	25.93	21.65	3.92
	62 (16.7)	35.20	31.75	2.31	33.85	31.13	2.57	32.01	31.87	2.83	30.18	30.18	3.12	28.33	28.33	3.48	26.52	26.52	3.92
	57 (13.9)	34.54	34.54	2.31	33.43	33.43	2.58	31.90	31.90	2.83	30.14	30.14	3.12	28.29	28.29	3.48	26.48	26.48	3.92
1200	72 (22.2)	41.83	22.41	2.34	39.99	21.78	2.63	37.64	20.98	2.91	35.04	20.11	3.22	32.39	19.23	3.58	29.84	18.39	4.02
	67 (19.4)	38.76	28.48	2.35	37.13	27.85	2.62	34.98	27.03	2.90	32.57	26.13	3.19	30.13	25.21	3.55	27.79	24.32	3.99
	63 (17.2)††	36.39	27.47	2.36	34.91	26.85	2.63	32.90	26.03	2.89	30.64	25.11	3.18	28.35	24.18	3.54	26.16	23.28	3.98
	62 (16.7)	35.97	35.97	2.36	34.75	34.75	2.63	33.08	33.08	2.89	31.17	31.17	3.18	29.19	29.19	3.54	27.24	27.24	3.99
	57 (13.9)	35.91	35.91	2.36	34.70	34.70	2.63	33.04	33.04	2.89	31.13	31.13	3.18	29.16	29.16	3.54	27.22	27.22	3.99
1350	72 (22.2)	42.12	23.50	2.40	40.23	22.86	2.69	37.82	22.05	2.97	35.16	21.18	3.28	32.45	20.29	3.64	29.86	19.44	4.09
	67 (19.4)	39.13	30.28	2.40	37.44	29.64	2.68	35.23	28.80	2.96	32.78	27.87	3.25	30.31	26.93	3.61	27.93	25.97	4.06
	63 (17.2)††	36.81	29.15	2.41	35.26	28.52	2.69	33.20	27.67	2.95	30.89	26.73	3.24	28.56	25.77	3.60	26.36	26.11	4.04
	62 (16.7)	37.06	37.06	2.41	35.74	35.74	2.68	33.96	33.96	2.95	31.94	31.94	3.25	29.84	29.84	3.61	27.79	27.79	4.05
	57 (13.9)	37.01	37.01	2.41	35.70	35.70	2.68	33.92	33.92	2.95	31.90	31.90	3.25	29.81	29.81	3.61	27.76	27.76	4.05

See notes on page 6

Specifications subject to change without notice.

421 51 6250 00

PRODUCT SPECIFICATIONS

Split System Air Conditioner: N4A5



# DETAILED COOLING CAPACITIES# CONTINUED

EVAPORATOR AIR		CONDENSER ENTERING AIR TEMPERATURES °F (°C)																	
CFM	EWB °F (°C)	75 (23.9)			85 (29.4)			95 (35)			105 (40.6)			115 (46.1)			125 (51.7)		
		Capacity MBtuh		Total System KW**	Capacity MBtuh		Total System KW**	Capacity MBtuh		Total System KW**	Capacity MBtuh		Total System KW**	Capacity MBtuh		Total System KW**	Capacity MBtuh		Total System KW**
		Total	Sens†		Total	Sens†		Total	Sens†		Total	Sens†		Total	Sens†		Total	Sens†	
<b>N4A542GKA Outdoor Section With EA*4X43L21** Indoor Section</b>																			
1200	72 (22.2)	48.28	25.79	2.74	46.16	24.99	3.00	43.98	24.17	3.29	41.66	23.31	3.63	39.16	22.40	4.04	36.41	21.40	4.50
	67 (19.4)	43.89	31.69	2.73	41.97	30.88	2.98	40.00	30.07	3.28	37.90	29.20	3.62	35.60	28.27	4.02	33.08	27.26	4.49
	63 (17.2)††	40.73	30.48	2.72	38.96	29.68	2.98	37.13	28.87	3.27	35.18	28.01	3.61	33.05	27.08	4.01	30.68	26.05	4.48
	62 (16.7)	39.99	37.46	2.72	38.27	36.64	2.97	36.52	35.78	3.27	34.69	34.69	3.61	32.98	32.98	4.01	31.05	31.05	4.48
	57 (13.9)	38.93	38.93	2.71	37.58	37.58	2.97	36.15	36.15	3.27	34.63	34.63	3.61	32.93	32.93	4.01	31.01	31.01	4.48
1400	72 (22.2)	49.27	27.40	2.83	47.02	26.58	3.08	44.73	25.75	3.37	42.31	24.87	3.71	39.69	23.94	4.11	36.83	22.93	4.58
	67 (19.4)	44.84	34.26	2.81	42.81	33.44	3.06	40.73	32.59	3.36	38.54	31.71	3.70	36.15	30.76	4.10	33.53	29.71	4.57
	63 (17.2)††	41.64	32.87	2.80	39.77	32.05	3.05	37.85	31.21	3.35	35.82	30.33	3.69	33.59	29.38	4.09	31.14	28.32	4.56
	62 (16.7)	41.13	40.72	2.80	39.50	39.50	3.05	37.95	37.95	3.35	36.27	36.27	3.69	34.43	34.43	4.10	32.35	32.35	4.56
	57 (13.9)	40.93	40.93	2.80	39.44	39.44	3.05	37.89	37.89	3.35	36.22	36.22	3.69	34.38	34.38	4.10	32.31	32.31	4.56
1575	72 (22.2)	49.87	28.75	2.90	47.56	27.92	3.15	45.18	27.07	3.44	42.68	26.18	3.78	39.99	25.24	4.18	37.06	24.23	4.65
	67 (19.4)	45.42	36.42	2.88	43.33	35.58	3.13	41.19	34.72	3.43	38.93	33.82	3.77	36.49	32.84	4.17	33.83	31.75	4.64
	63 (17.2)††	42.22	34.88	2.87	40.28	34.04	3.12	38.30	33.18	3.42	36.20	32.27	3.76	33.93	31.29	4.16	31.44	30.18	4.63
	62 (16.7)	42.38	42.38	2.87	40.78	40.78	3.13	39.13	39.13	3.42	37.35	37.35	3.77	35.40	35.40	4.17	33.21	33.21	4.64
	57 (13.9)	42.32	42.32	2.87	40.73	40.73	3.13	39.08	39.08	3.42	37.31	37.31	3.77	35.35	35.35	4.17	33.17	33.17	4.64

EVAPORATOR AIR		CONDENSER ENTERING AIR TEMPERATURES °F (°C)																	
CFM	EWB °F (°C)	75 (23.9)			85 (29.4)			95 (35)			105 (40.6)			115 (46.1)			125 (51.7)		
		Capacity MBtuh		Total System KW**	Capacity MBtuh		Total System KW**	Capacity MBtuh		Total System KW**	Capacity MBtuh		Total System KW**	Capacity MBtuh		Total System KW**	Capacity MBtuh		Total System KW**
		Total	Sens†		Total	Sens†		Total	Sens†		Total	Sens†		Total	Sens†		Total	Sens†	
<b>N4A548GKA Outdoor Section With EA*4X61L24** Indoor Section</b>																			
1400	72 (22.2)	53.91	26.70	3.12	51.70	25.95	3.46	49.29	25.14	3.81	46.61	24.25	4.20	43.50	23.23	4.66	39.94	22.07	5.22
	67 (19.4)	49.07	33.08	3.15	47.03	32.30	3.47	44.83	31.48	3.81	42.36	30.56	4.19	39.52	29.52	4.65	36.26	28.33	5.22
	63 (17.2)††	45.60	31.80	3.16	43.67	31.02	3.48	41.61	30.19	3.81	39.31	29.27	4.18	36.66	28.22	4.64	33.61	27.02	5.22
	62 (16.7)	44.81	39.26	3.16	42.96	38.43	3.48	41.03	40.90	3.80	39.14	39.14	4.18	36.99	36.99	4.64	34.49	34.49	5.22
	57 (13.9)	44.02	44.02	3.16	42.51	42.51	3.48	40.91	40.91	3.80	39.08	39.08	4.18	36.94	36.94	4.64	34.44	34.44	5.22
1600	72 (22.2)	54.74	28.18	3.20	52.46	27.42	3.54	49.97	26.60	3.89	47.17	25.68	4.28	43.95	24.64	4.74	40.30	23.48	5.30
	67 (19.4)	49.91	35.43	3.22	47.78	34.64	3.55	45.50	33.80	3.89	42.95	32.87	4.27	40.01	31.79	4.73	36.67	30.58	5.30
	63 (17.2)††	46.41	33.99	3.23	44.41	33.19	3.55	42.28	32.35	3.89	39.89	31.40	4.26	37.15	30.32	4.72	34.04	29.09	5.30
	62 (16.7)	45.97	45.97	3.23	44.36	44.36	3.55	42.62	42.62	3.89	40.65	40.65	4.27	38.35	38.35	4.73	35.68	35.68	5.30
	57 (13.9)	45.90	45.90	3.23	44.29	44.29	3.55	42.56	42.56	3.89	40.59	40.59	4.27	38.30	38.30	4.73	35.63	35.63	5.30
1800	72 (22.2)	55.35	29.59	3.27	53.00	28.82	3.62	50.43	27.99	3.97	47.55	27.07	4.35	44.26	26.02	4.82	40.51	24.83	5.38
	67 (19.4)	50.51	37.70	3.29	48.34	36.90	3.63	45.99	36.05	3.97	43.37	35.09	4.35	40.38	33.98	4.81	37.00	32.68	5.38
	63 (17.2)††	47.02	36.10	3.31	44.97	35.29	3.63	42.77	34.42	3.97	40.33	33.45	4.34	37.54	32.33	4.81	34.39	30.98	5.38
	62 (16.7)	47.51	47.51	3.31	45.80	45.80	3.63	43.96	43.96	3.97	41.87	41.87	4.35	39.44	39.44	4.81	36.63	36.63	5.38
	57 (13.9)	47.45	47.45	3.31	45.74	45.74	3.63	43.91	43.91	3.97	41.82	41.82	4.35	39.40	39.40	4.81	36.58	36.58	5.38

See notes on page 6

Specifications subject to change without notice.

# DETAILED COOLING CAPACITIES# CONTINUED

EVAPORATOR AIR		CONDENSER ENTERING AIR TEMPERATURES °F (°C)																	
CFM	EWB °F (°C)	75 (23.9)			85 (29.4)			95 (35)		105 (40.6)			115 (46.1)		125 (51.7)				
		Capacity MBtuh	Total System KW**		Capacity MBtuh	Total System KW**		Capacity MBtuh	Total System KW**	Capacity MBtuh	Total System KW**		Capacity MBtuh	Total System KW**	Capacity MBtuh	Total System KW**			
<b>N4A560GKA Outdoor Section With EA*4X60L24** Indoor Section</b>																			
1750	72 (22.2)	68.41	35.82	4.01	65.35	34.67	4.39	62.15	33.49	4.86	58.70	32.23	5.39	55.01	30.89	5.96	50.87	29.41	6.55
	67 (19.4)	62.24	44.04	4.01	59.41	42.88	4.38	56.50	41.69	4.83	53.38	40.43	5.35	50.00	39.08	5.91	46.23	37.59	6.49
	63 (17.2)††	57.78	42.37	4.02	55.13	41.19	4.37	52.41	39.99	4.81	49.54	38.75	5.32	46.39	37.40	5.87	42.89	35.91	6.45
	62 (16.7)	56.92	52.17	4.02	54.40	50.96	4.37	51.84	49.69	4.81	49.16	49.16	5.32	46.64	46.64	5.88	43.73	43.73	6.46
	57 (13.9)	55.64	55.64	4.02	53.56	53.56	4.37	51.43	51.43	4.81	49.13	49.13	5.32	46.56	46.56	5.88	43.68	43.68	6.46
2000	72 (22.2)	69.54	37.55	4.10	66.36	36.39	4.49	63.04	35.18	4.96	59.50	33.91	5.49	55.63	32.53	6.06	51.36	31.03	6.66
	67 (19.4)	63.30	46.83	4.11	60.35	45.64	4.47	57.34	44.44	4.93	54.11	43.16	5.45	50.61	41.77	6.01	46.74	40.24	6.60
	63 (17.2)††	58.79	44.95	4.11	56.04	43.76	4.47	53.23	42.55	4.91	50.24	41.27	5.42	47.00	39.89	5.98	43.39	38.33	6.56
	62 (16.7)	58.25	55.83	4.11	55.72	55.33	4.47	53.37	53.37	4.91	50.91	50.91	5.43	48.16	48.16	5.99	45.09	45.09	6.58
	57 (13.9)	57.80	57.80	4.11	55.59	55.59	4.47	53.30	53.30	4.91	50.84	50.84	5.43	48.11	48.11	5.99	45.03	45.03	6.58
2250	72 (22.2)	70.37	39.17	4.20	67.10	37.99	4.59	63.67	36.77	5.06	60.02	35.48	5.59	56.04	34.08	6.17	51.66	32.55	6.76
	67 (19.4)	64.08	49.47	4.20	61.08	48.28	4.57	57.95	47.04	5.03	54.64	45.73	5.55	51.07	44.31	6.12	47.12	42.69	6.70
	63 (17.2)††	59.56	47.41	4.20	56.73	46.20	4.56	53.82	44.95	5.01	50.77	43.65	5.52	47.44	42.21	6.08	43.78	40.57	6.66
	62 (16.7)	59.69	59.69	4.20	57.32	57.32	4.56	54.90	54.90	5.02	52.28	52.28	5.53	49.41	49.41	6.10	46.17	46.17	6.69
	57 (13.9)	59.58	59.58	4.20	57.25	57.25	4.56	54.83	54.83	5.02	52.23	52.23	5.53	49.35	49.35	6.10	46.12	46.12	6.69

† Total and sensible capacities are net capacities. Blower motor heat has been subtracted.

‡ Sensible capacities shown are based on 80°F (27°C) entering air at the indoor coil. For sensible capacities at other than 80°F (27°C), deduct 835 Btuh (245 kW) per 1000 CFM (480 L/S) of indoor coil air for each degree below 80°F (27°C), or add 835 Btuh (245 kW) per 1000 CFM (480 L/S) of indoor coil air per degree above 80°F (27°C).

# Detailed cooling capacities are based on indoor and outdoor unit at the same elevation per AHRI standard 210/240—2008. If additional tubing length and/or indoor unit is located above outdoor unit, a slight variation in capacity may occur.

\*\* System kw is total of indoor and outdoor unit kilowatts.

†† At TVA rating indoor condition (75°F edb/63°F ewb). All other indoor air temperatures are at 80°F edb.

NOTE: When the required data falls between the published data, interpolation may be performed. Extrapolation is not an acceptable practice.

EWB — Entering Wet Bulb

### ACCESSORY USAGE GUIDELINE

ACCESSORY	REQUIRED FOR LOW-AMBIENT COOLING APPLICATIONS (Below 55°F/12.8°C)	REQUIRED FOR LONG LINE APPLICATIONS* (Over 80 ft./24.38 m)	REQUIRED FOR SEA COAST APPLICATIONS (Within 2 miles/3.22 km)
Compressor Start Assist Capacitor and Relay	Yes	Yes	No
Crankcase Heater	Yes	Yes	No
Evaporator Freeze Thermostat	Yes	No	No
Hard Shut-Off TXV	Yes	Yes	Yes
Liquid Line Solenoid Valve	No	No	No
Low-ambient Pressure Switch	Yes†	No	No
Support Feet	Recommended	No	Recommended
Winter Start Control	Yes **	No	No

\* For tubing line sets between 80 and 200 ft. (24.38 and 60.96 m) and/or 20 ft. (6.09 m) vertical differential, refer to Residential Split-System Longline Application Guideline

\*\* Can only be installed in conjunction with Low Pressure Switch

† Required for Low-Ambient Controller Control

### ACCESSORIES

Part Number	Description	Used On Model Size
NASA001CH	Crankcase Heater for Scroll Compressor (208/230 V)	42 – 60
NASA003CH	Crankcase Heater for Scroll Compressor (208/230 V)	18 – 36
NASA001SC	Start Component – PTC Device	24 – 60
NASA00201FS	Evaporator Freeze Thermostat	ALL
NASA403PS	Low Pressure Switch, AC, R-410A	ALL
NASA401LS	Liquid Line Solenoid Valve, R-410A	ALL
NASA001TD	Time Delay Relay, Indoor Blower	ALL
NASA00201WS	Winter Start Control	ALL
NASA001AC	Anti-Cycle Timer (5 minute delay)	ALL
NASA404PS	High Pressure Switch, AC or HP, R-410A	ALL
NASA005SC	Hard Start Kit (Capacitor & Relay)	ALL
NASA401LA	Low Ambient Kit (Pressure Switch), R-410A	ALL
NASA00201SF	Support Feet, 4" (102mm) tall (5 blocks)	18 – 36
NASA001SF	Support Feet, 4" (102mm) tall (4 blocks)	42 – 60
NASA001SJ	Sound Jacket, Compressor	18 – 48
NASA003SJ	Sound Jacket, Compressor	60
EBAC05TXVX	TXV Kit, R-410A – 2005–2009 R-22 TXV Fancoils (air handlers)	18 – 30
EBAC06TXVX	TXV Kit, R-410A – 2005–2009 R-22 TXV Fancoils (air handlers)	36 – 42
EBAC07TXVX	TXV Kit, R-410A – 2005–2009 R-22 TXV Fancoils (air handlers)	48 – 60
NAEA40501TX	TXV Kit, R-410A for use with copper or tin fan coils	18 – 30
NAEA40601TX	TXV Kit, R-410A for use with copper or tin fan coils	36 – 42
NAEA40701TX	TXV Kit, R-410A for use with copper or tin fan coils	60
NAEA40501TX	TXV Kit, R-410A for use with aluminum fan coils	18 – 30
NAEA40601TX	TXV Kit, R-410A for use with aluminum fan coils	36 – 42
NAEA40701TX	TXV Kit, R-410A for use with aluminum fan coils	60